

WARDROBES

[ITA] **ISTRUZIONI DI MONTAGGIO**

[ENG] ASSEMBLY

[DEU] MONTAGEANLEITUNGEN

Indice generale
Index
Inhaltsverzeichnis

- | | | | |
|----|---|----|---|
| 4 | Regolazione cerniere
<i>Hinges adjustment</i>
<i>Einstellung der Scharniere.</i> | 27 | Anta ALLISON
<i>ALLISON door</i>
<i>Tür ALLISON</i> |
| 6 | Armadio Battente/Pieghevole
<i>Hinged/Folding Door Wardrobe</i>
<i>Schränke mit Flügel-/ Falttüren</i> | 28 | Anta PICTURE
<i>PICTURE door</i>
<i>Tür PICTURE</i> |
| 7 | Ante pieghevoli
<i>Folding doors</i>
<i>Falttören</i> | 30 | Angolo spogliatoio
<i>Walk-in closet</i>
<i>Begehbarer Schrank</i> |
| 8 | Soluzione Ponte
<i>Bridging solution</i>
<i>Brückenlösungen</i> | 31 | Posizionamento anta ripostiglio/cabina
<i>Walk-in cupboard/closet door positioning</i>
<i>Positionierung der Türen für Abstellräume/Begehbare Schränke</i> |
| 9 | Nicchie e portali MAXI
<i>Recesses and MAXI portal</i>
<i>Nische und Portal MAXI</i> | 32 | Pannello cielo sagomato
<i>Shaped ceiling panel</i>
<i>Geformtes Deckenpaneel</i> |
| 11 | Nicchia con specchio
<i>Recess with mirror</i>
<i>Nische mit Spiegel</i> | 34 | Struttura di chiusura
<i>Closing system structure</i>
<i>Türsysteme</i> |
| 12 | Ponte con consolle
<i>Bridge with consolle</i>
<i>Brück mit Consolle</i> | 35 | Fianco terminale cabina tipo 1
<i>Walk-in closet end side panel type 1</i>
<i>Abschließende Seitenwand des Begehbaren Schrankes Typ 1</i> |
| 13 | Armadio ad angolo
<i>Corner wardrobe</i>
<i>Eckschränke</i> | 36 | Montanti pentagonali
<i>Pentagonal uprights</i>
<i>Fünfeckiger Pfosten</i> |
| 15 | Paracolpi per ante ad angolo
<i>Buffers for corner doors</i>
<i>Anschlagdämpfer für Ecktüren</i> | 37 | Tubo appendiabiti
<i>Hanging rail</i>
<i>Kleiderstangen</i> |
| 16 | Anta PERRY
<i>PERRY door</i>
<i>Tür PERRY</i> | 38 | Porta abiti laterale esterno
<i>External side hanging rail</i>
<i>Seitliche Kleiderstange für die Außenseite der Schrankseitenwand</i> |
| 17 | Armadio scorrevole
<i>Sliding door wardrobe</i>
<i>Schiebetürenschränk</i> | 40 | Cassetti esterni armadio
<i>External wardrobe drawers</i>
<i>Schubladen für Schränke</i> |
| 14 | Elemento in nicchia
<i>Assembly in a recess</i>
<i>Nischenelement</i> | 41 | Ripiano luce LED
<i>LED light shelf</i>
<i>Einlegeboden mit LED-Beleuchtung</i> |
| 20 | Barra di rinforzo per armadio scorrevole
<i>Reinforcing bar for sliding door wardrobe</i>
<i>Verstärkungsleiste für Schiebetürenschränke</i> | 42 | Assieme porta TV
<i>TV unit</i>
<i>TV Träger-Set</i> |
| 21 | Regolazione anta ALFA-GOLA
<i>Alfa-Gola door adjustment.</i>
<i>Einstellung ALFA-GOLA Tür</i> | 43 | Cassettiera interna armadio
<i>Wardrobe interior drawer unit</i>
<i>Inneres Schubladenelement im Schrank</i> |
| 22 | Anta Maxi CRYSTAL
<i>CRYSTAL Maxi door</i>
<i>Tür Maxi CRYSTAL</i> | 44 | Montante compensatore
<i>Filler upright</i>
<i>Ausgleichspfosten</i> |
| 24 | Anta MIDDLE / CLASS
<i>MIDDLE / CLASS door</i>
<i>Tür MIDDLE / CLASS</i> | 45 | Fasce di aggiustamento
<i>Adjustment strips</i>
<i>Passblenden</i> |
| 26 | Anta OFFSET
<i>OFFSET door</i>
<i>Tür OFFSET</i> | 46 | Terminale laterale
<i>Side end unit</i>
<i>Seitliches Schlusselement</i> |

[ITA] REGOLAZIONE CERNIERE

[ENG] HINGES ADJUSTMENT

[DEU] EINSTELLUNG DER SCHARNIERE



[ITA] L'installazione deve essere eseguita da personale specializzato.
[ENG] Installation must be carried out by specialized personnel
[DEU] Ausgebildetem Fachpersonal vorgekommen werden



[ITA] Un cacciavite medio a stella
[ENG] Medium Phillips screwdriver
[DEU] Mittelgroßer Kreuzschlitzschraubendreher

[ITA] REGOLAZIONE LATERALE

[ENG] LATERAL ADJUSTMENT

[DEU] VERSTELLUNG NACH RECHTS UND LINKS

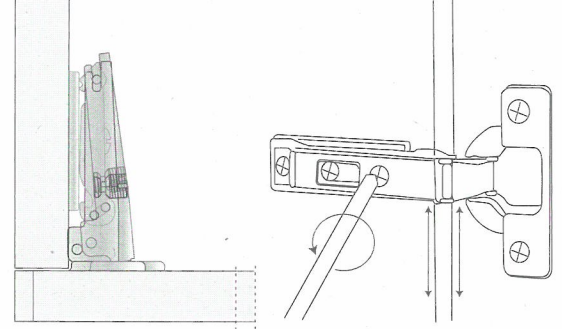
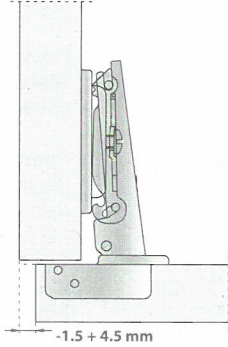
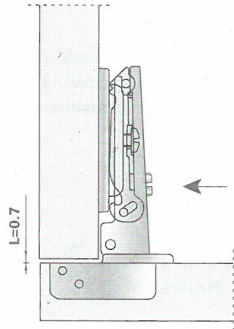
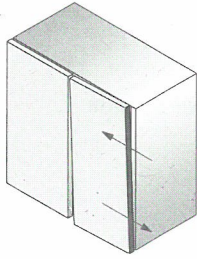

[ITA] REGOLAZIONE FRONTALE

[ENG] FRONT ADJUSTMENT

[DEU] VERSTELLUNG DER FRONTNEIGUNG

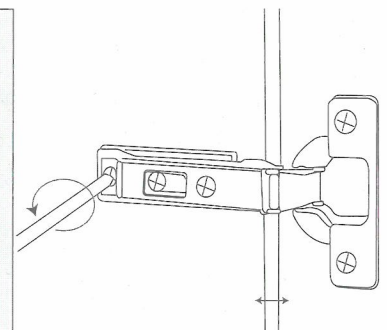
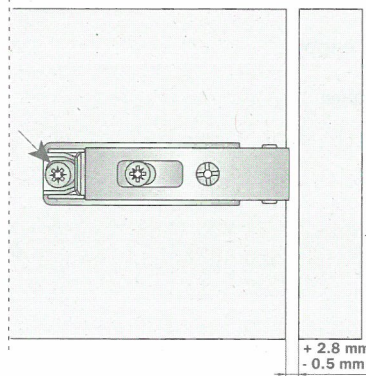
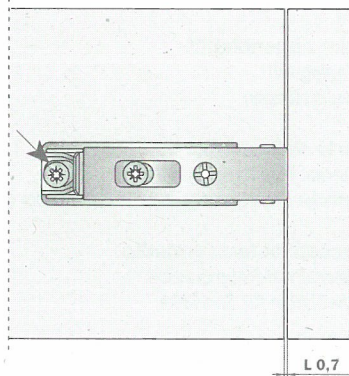
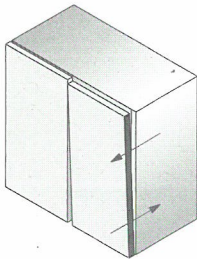

[ITA] REGOLAZIONE VERTICALE

[ENG] VERTICAL ADJUSTMENT

[DEU] VERSTELLUNG NACH OBEN ND UNTEN

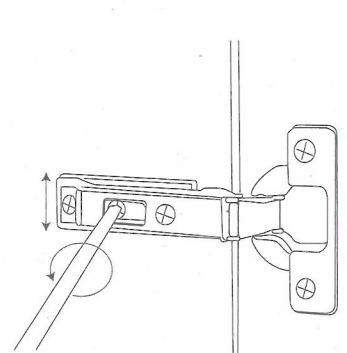
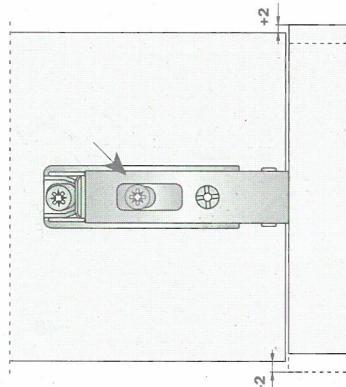
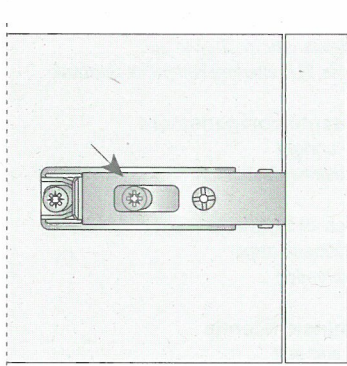
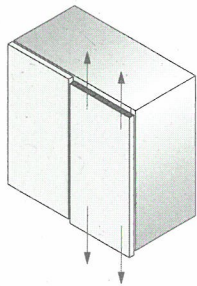

[ITA] REGOLAZIONE CERNIERE RALLENTATE (OPZIONALI)

[ENG] HINGES ADJUSTMENT

[DEU] EINSTELLUNG DER SCHARNIERE



[ITA] L'installazione deve essere eseguita da personale specializzato.

[ENG] Installation must be carried out by specialized personnel

[DEU] Ausgebildetem Fachpersonal vorgenommen werden



GUARDA IL VIDEO!
Look at the video!
Video ansehen!

[ITA] Le cerniere rallentate sono dotate di selettore per aumentare (+) o diminuire (-) la forza frenante.

[ENG] The slowed hinges have a selector to increase (+) or decrease (-) the braking force.

[DEU] Die verlangsamt Scharniere haben einen Wahlschalter, um die Bremskraft zu erhöhen (+) oder zu verringern (-).

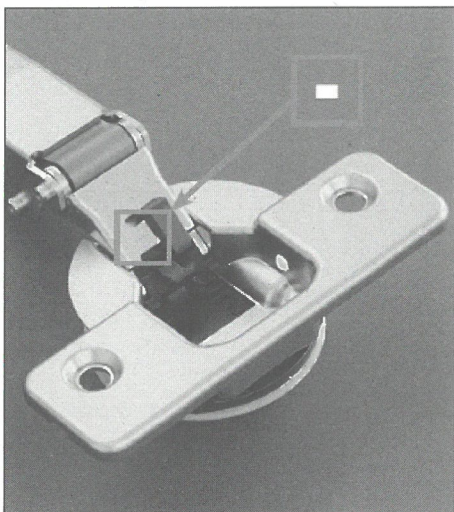
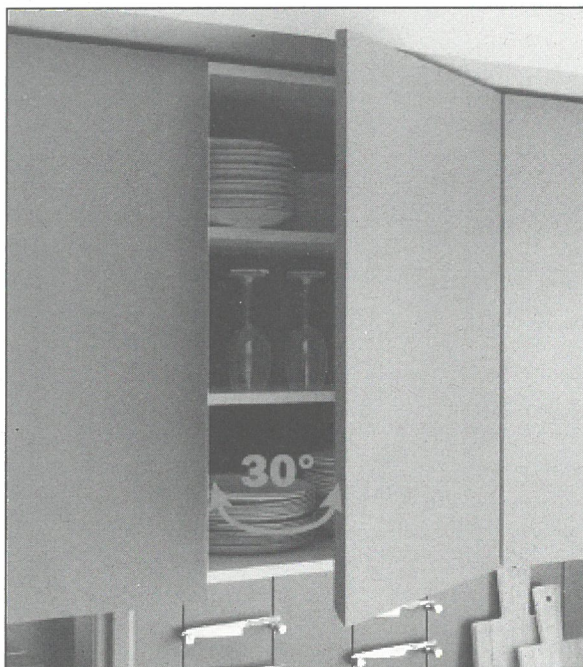
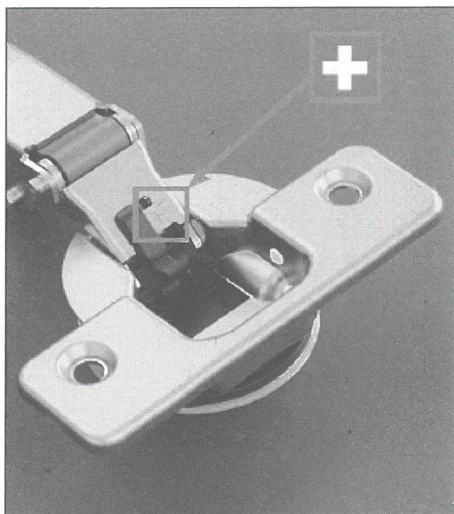

[ITA] ARMADI BATTENTI/PIEGHEVOLI
[ENG] HINGED/FOLDING DOOR WARDROBES
[DEU] SCHRÄNKE MIT FLÜGEL-/ FALTTÜREN



[ITA] L'installazione deve essere eseguita da personale specializzato.
 [ENG] Installation must be carried out by specialized personnel
 [DEU] Ausgebildetem Fachpersonal vorgenommen werden

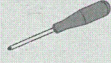

[ITA] Un cacciavite medio a stella
 [ENG] Medium Phillips screwdriver
 [DEU] Mittelgroßer Kreuzschlitzschraubendreher



A
 Reggiriapiano
 Shelf support
 Einlegebodenträger



B
 Tirante Ø10
 Ø10 tie
 Verbindungsbolzen Ø10



C
 Tappo copriforo Ø12
 Ø12 hole cap
 Verschlusskappe Ø12



D
 Fermaschiena
 Back retainer
 Rückwandhalter



E
 Vite TPS Ø3,5x16
 Ø3,5x16 flat head
 countersunk screw
 Schrauben TPS Ø3,5x16

[ITA] I pezzi sono numerati in ordine di montaggio, inoltre devono sempre essere montati da SX verso DX.

[ENG] Parts are numbered in the order they are assembled in. In addition, they must always be fitted from left to right.

[DEU] Die einzelnen Stücke sind entsprechend Der Montagefolge durchnummeriert. Führen Sie die Montage immer von links nach rechts durch.

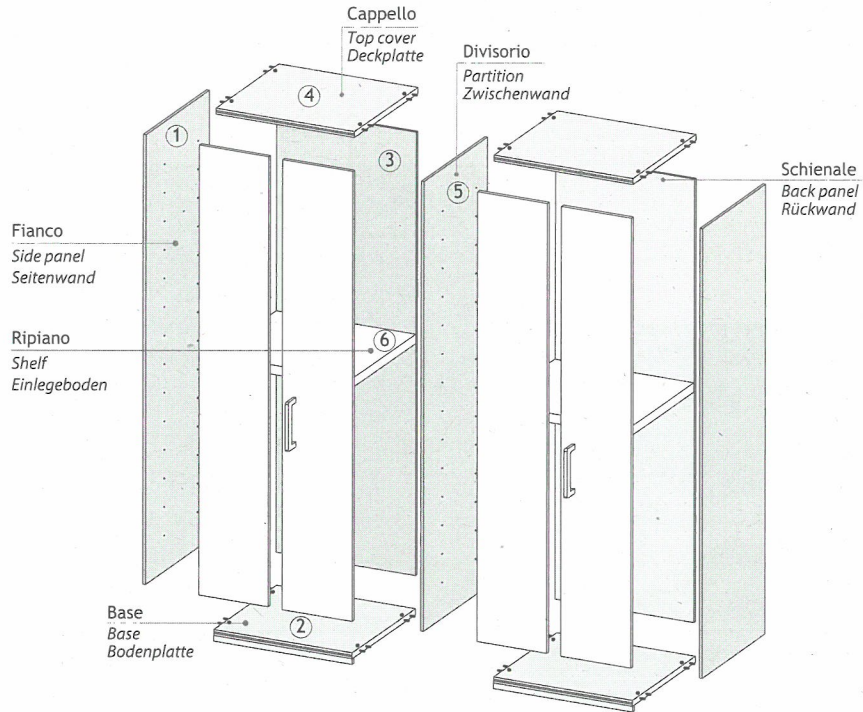

- 1 - Montaggio della base al fianco
- 1 - Fitting the base to the side panel
- 1 - Montage der Bodenplatte an der Seitenwand

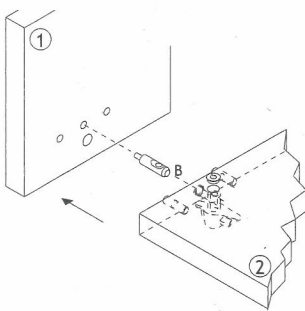

- 2 - Montaggio dello schienale
- 2 - Fitting the back panel
- 2 - Montage der Rückwand

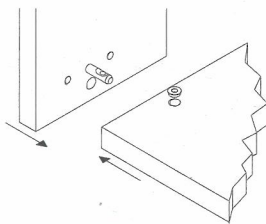
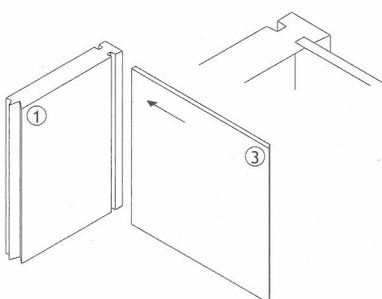

- 3 - Montaggio del ripiano
- 3 - Fitting the shelf
- 3 - Montage des Einlegebodens

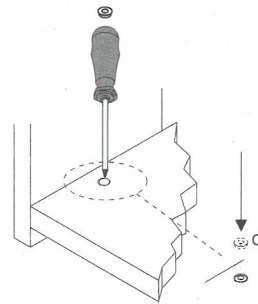
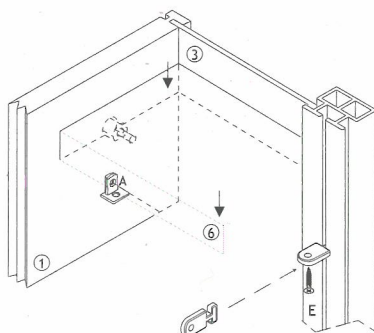

- 4 - Regolazione
- 4 - Adjustment
- 4 - Einstellung

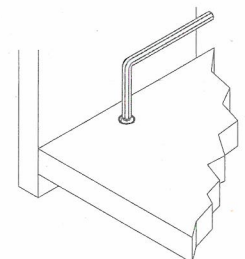

[ITA] ANTE PIEGHEVOLI

[ENG] FOLDING DOORS

[DEU] FALTTÜREN



[ITA] L'installazione deve essere eseguita da personale specializzato.
 [ENG] Installation must be carried out by specialized personnel
 [DEU] Ausgebildetem Fachpersonal vorgenommen werden



[ITA] Un cacciavite medio a stella
 [ENG] Medium Phillips screwdriver
 [DEU] Mittelgroßer Kreuzschlitzschraubendreher

A



Vite TSP M6x16
 M6x16 flat head countersunk screw
 Schrauben TSP M6x16

B



Cerniera
 Hinge
 Scharnier

[ITA] ATTENZIONE!!! Prima di montare l'armadio inserire i carrelli (ai quali verranno successivamente agganciate le ante) nel binario già fissato al cappello.

[ENG] PLEASE NOTE!!! Before assembling the wardrobe, make sure you insert the runners (that the doors will then be attached to) in the track already fastened to the top cover.

[DEU] ACHUNG!!! Vor der Montage des Schrankes müssen die Gleitschuhe in die bereits an der Deckplatte befestigten Schienen eingesetzt werden (die Türen werden später in die Gleitschuhe eingehängt).

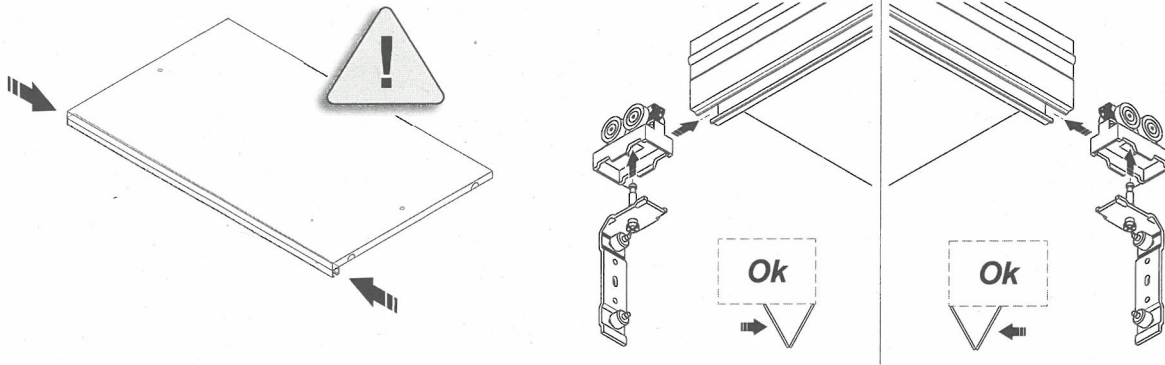

FISSAGGIO DELLA CERNIERA
 FASTENING THE HINGE
 BEFESTIGUNG DES SCHARNIERS

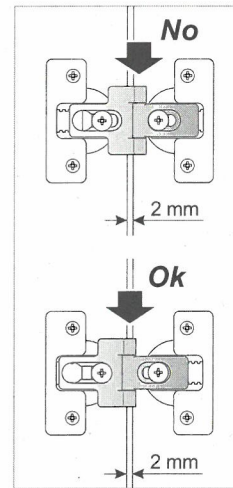
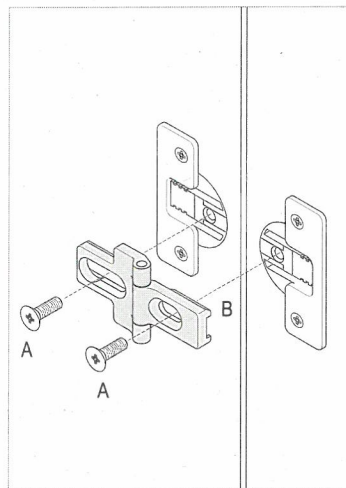
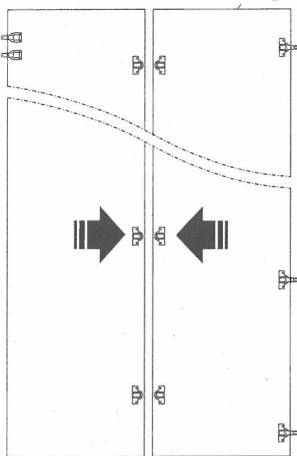

Particolare fissaggio del carrello alle cerniere.
 Detail of runner attachment to hinges.
 Detailansicht der Befestigung von Gleitschuh und Scharnieren.

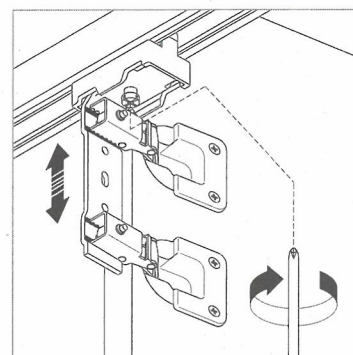
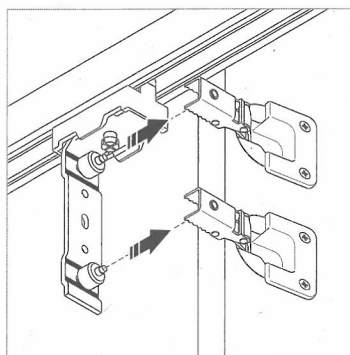
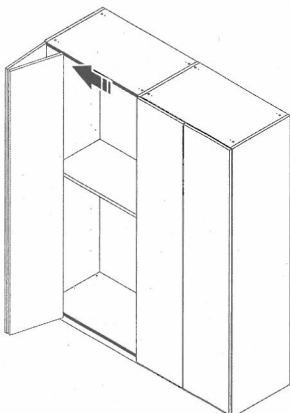

[ITA] SOLUZIONE A PONTE
 [ENG] BRIDGING SOLUTION
 [DEU] BRÜCKENLÖSUNG



[ITA] L'installazione deve essere eseguita da personale specializzato.
 [ENG] Installation must be carried out by specialized personnel
 [DEU] Ausgebildetem Fachpersonal vorgenommen werden

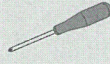

[ITA] Un cacciavite medio a stella
 [ENG] Medium Phillips screwdriver
 [DEU] Mittelgroßer Kreuzschlitzschraubendreher

A
 Fermaschiena
 Back retainer
 Rückwandhalter

B
 Vite TPS Ø3,5x16
 Ø3,5x16 flat head countersunk screw
 Schrauben TPS Ø3,5x16

C
 Vite TBL M6x15
 M6x15 truss head screw
 Schrauben TBL M6x15

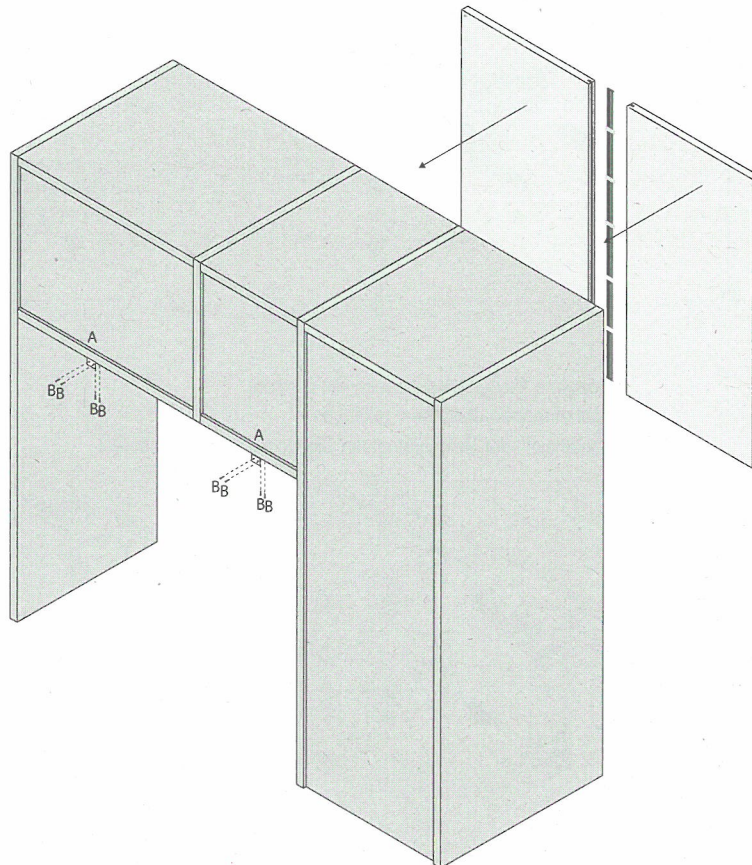
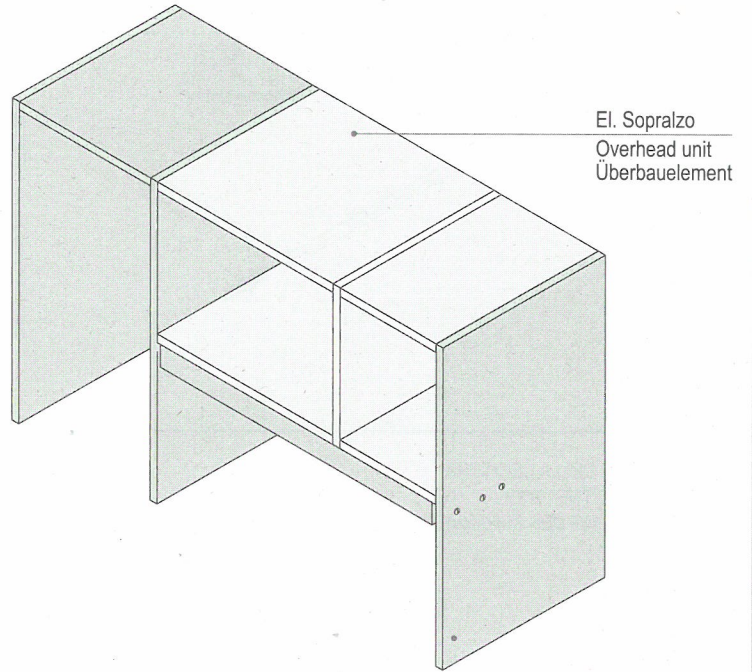
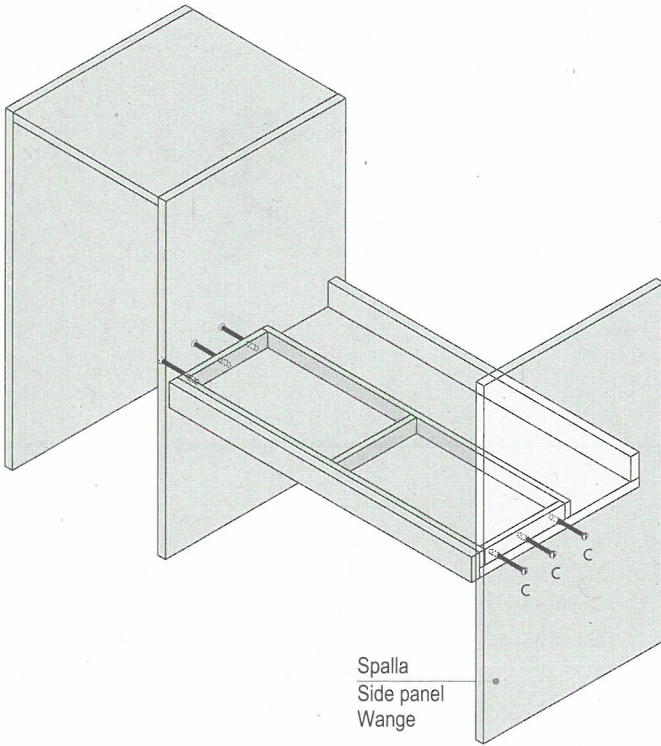

[ITA] NICCHIE E PORTALE MAXI

[ENG] MAXI PORTAL

[DEU] PORTAL MAXI



[ITA] L'installazione deve essere eseguita da personale specializzato.

[ENG] Installation must be carried out by specialized personnel

[DEU] Ausgebildetem Fachpersonal vorgenommen werden



[ITA] Un cacciavite medio a stella

[ENG] Medium Phillips screwdriver

[DEU] Mittelgroßer Kreuzschlitzschraubendreher

A



Reggripiano
Shelf support
Einlegebodenträger

B



Tirante Ø10
Ø10 tie
Verbindungsbolzen Ø10

C



Tappo copriforo Ø12
Ø12 hole cap
Verschlusskappe Ø12

D



Fermaschiena
Back retainer
Rückwandhalter

E



Vite TPS Ø3,5x16
Ø3,5x16 flat head
countersunk screw
Schrauben TPS Ø3,5x16

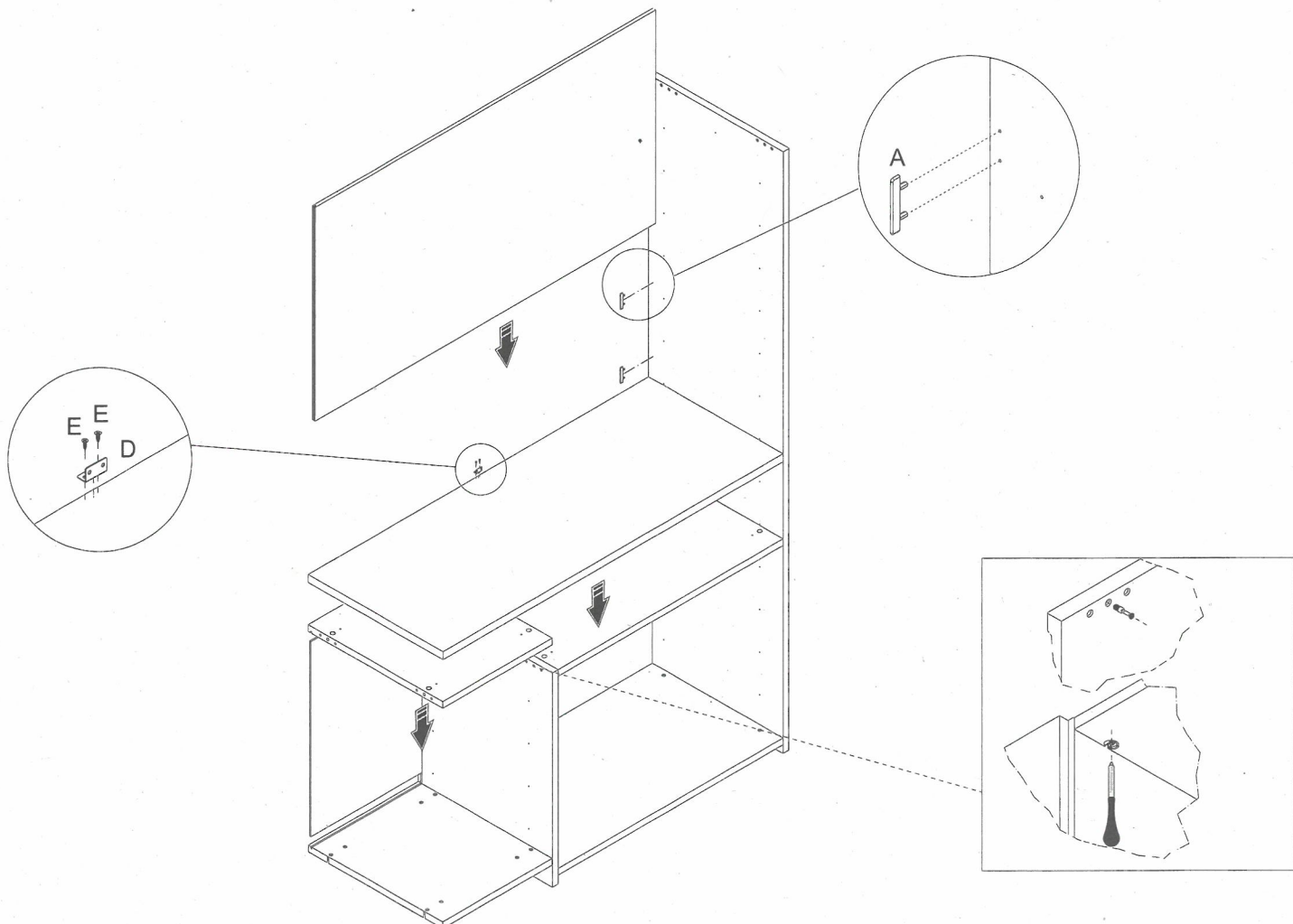
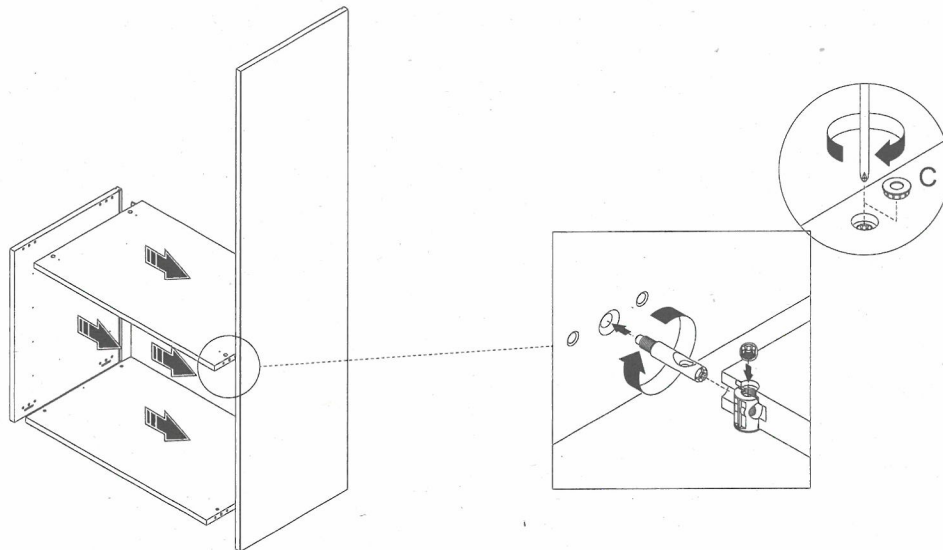

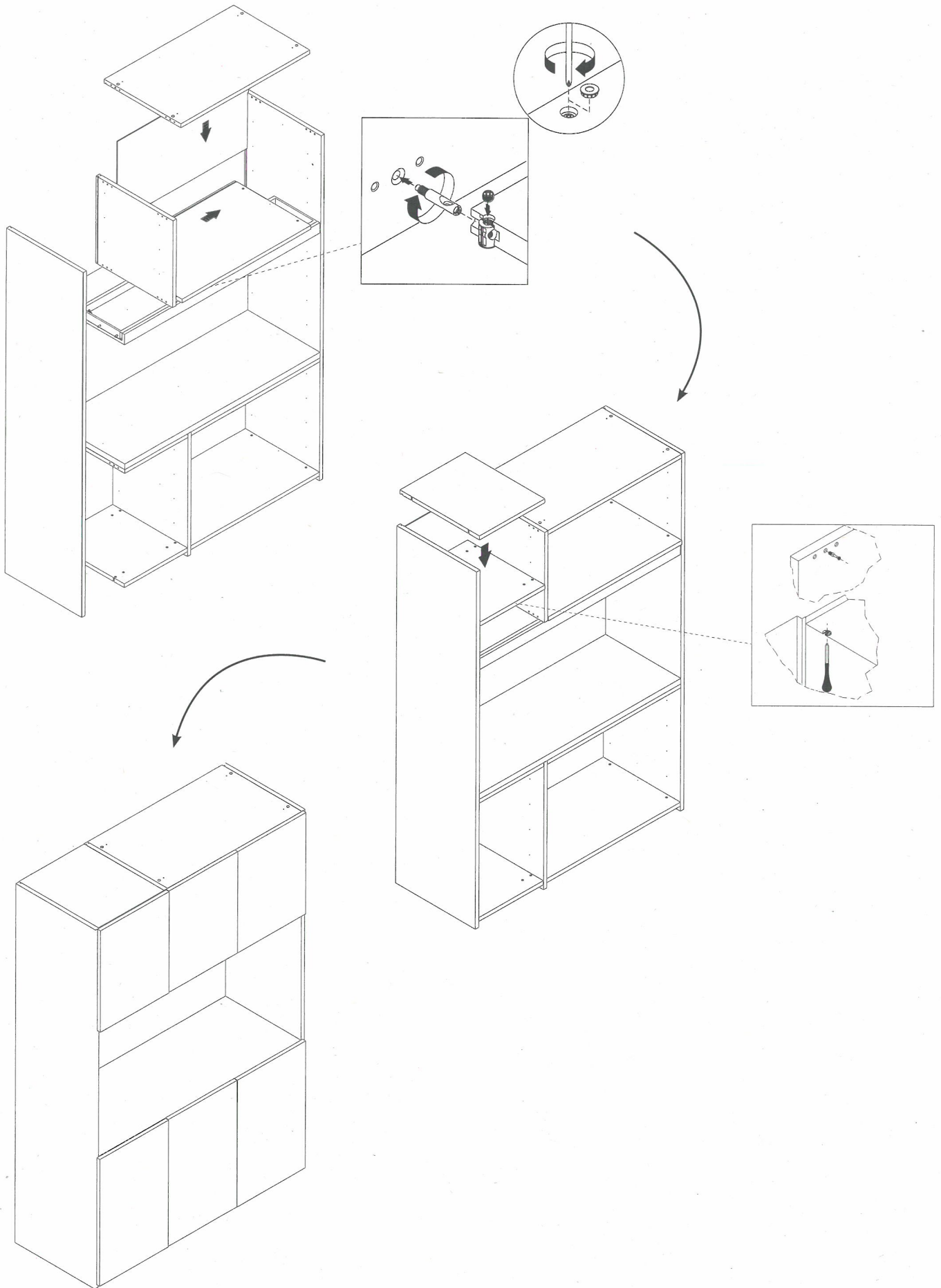

Regolazione

A montaggio terminato con la chiave esagonale agire sul piede premontato sulla base per livellare l'armadio.

Adjustment

Once assembly is complete, use the Allen key to adjust the foot ready fitted on the base to level the wardrobe.

Einstellung

Nach Ende der Montage richten Sie den Schrank durch Drehen am vormontierten Stellfuß mit einem Inbusschlüssel waagrecht aus.

[ITA] PORTALE CON SPECCHIO

[ENG] RECESS WITH MIRROR

[DEU] NICHE MIT SPIEGEL



[ITA] L'installazione deve essere eseguita da personale specializzato.
 [ENG] Installation must be carried out by specialized personnel
 [DEU] Ausgebildetem Fachpersonal vorgenommen werden



[ITA] Un cacciavite medio a stella
 [ENG] Medium Phillips screwdriver
 [DEU] Mittelgroßer Kreuzschlitzschraubendreher

A



Vite TBL 6x40
 M6x40 truss head screw
 Schrauben TBL 6x40

D



Vite TB 4,2x15
 TB 4,2x15 screw
 Schrauben TB 4,2x15

G



Vite TBL M4x10
 TBL M4x10 screw
 Schrauben TBL M4x10

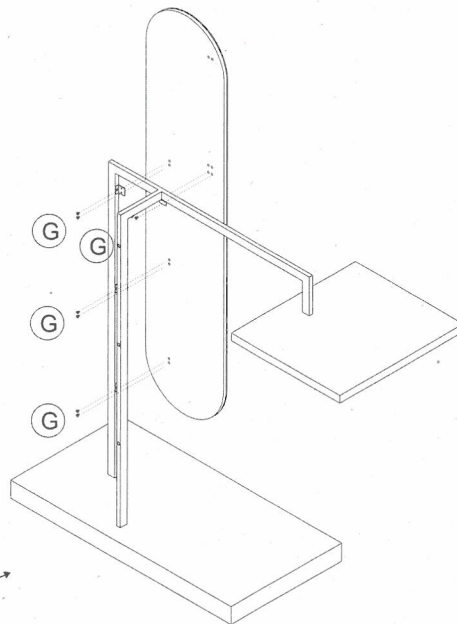
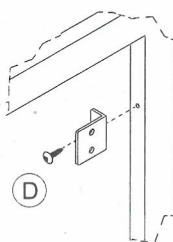
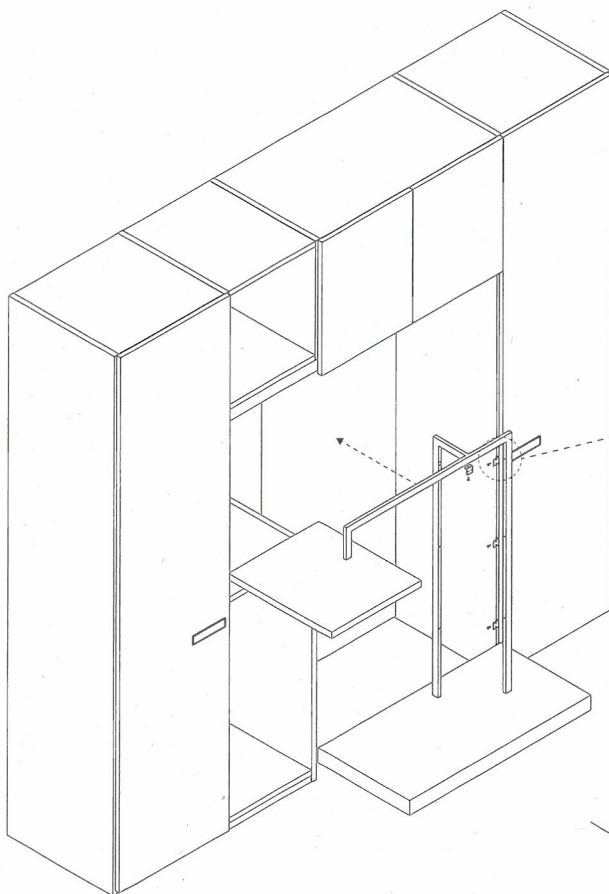
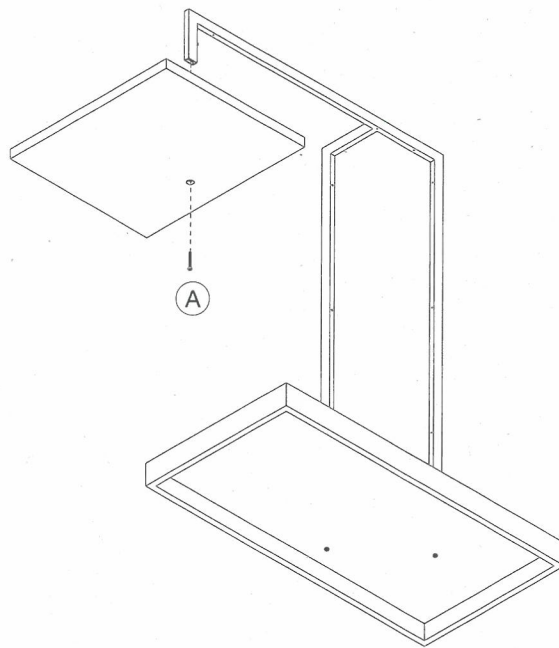
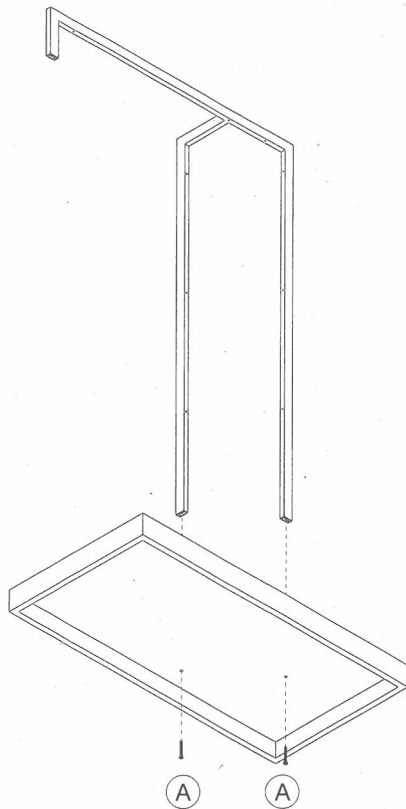

[ITA] PONTE CON CONSOLLE

[ENG] BRIDGE WITH CONSOLLE

[DEU] BRÜCK MIT CONSOLLE



[ITA] L'installazione deve essere eseguita da personale specializzato.
[ENG] Installation must be carried out by specialized personnel
[DEU] Ausgebildetem Fachpersonal vorgenommen werden



[ITA] Un cacciavite medio a stella
[ENG] Medium Phillips screwdriver
[DEU] Mittelgroßer Kreuzschlitzschraubendreher

A



Attaccaglia
Back retainer
Rückwandhalterung

B



Vite TPS Ø3,5x16
Ø3,5x16 flat head countersunk screw
Schrauben TPS Ø3,5x16

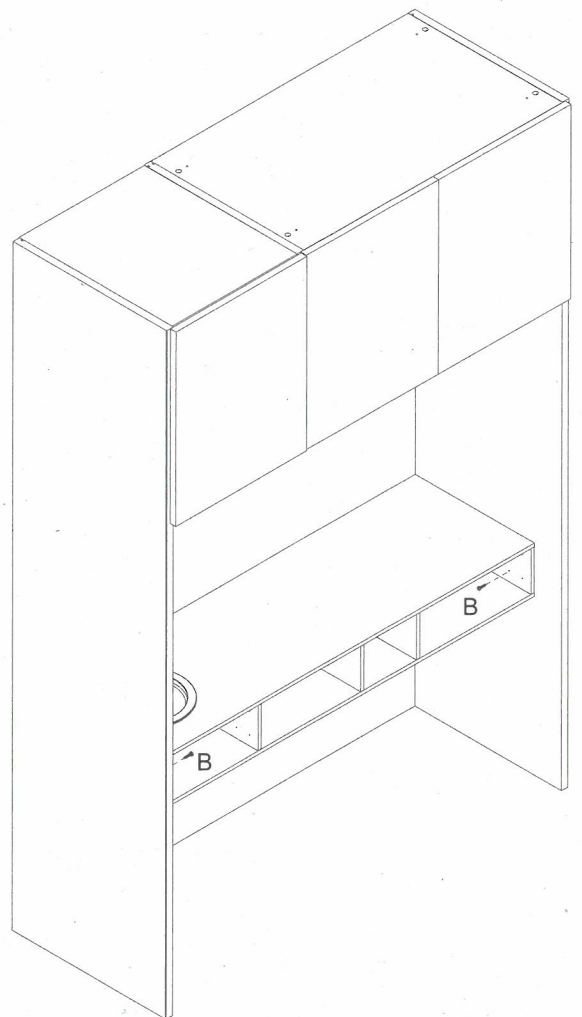
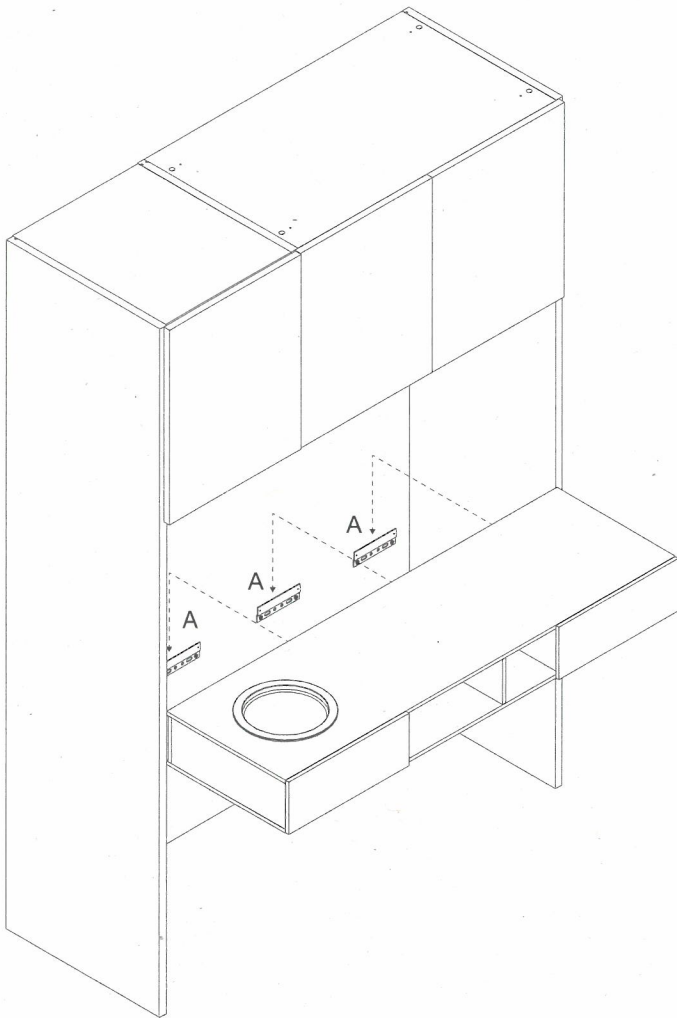

[ITA] ARMADIO AD ANGOLO

[ENG] CORNER WARDROBE

[DEU] ECKSCHRANK



[ITA] L'installazione deve essere eseguita da personale specializzato.
 [ENG] Installation must be carried out by specialized personnel
 [DEU] Ausgebildetem Fachpersonal vorgenommen werden



[ITA] Un cacciavite medio a stella
 [ENG] Medium Phillips screwdriver
 [DEU] Mittelgroßer Kreuzschlitzschraubendreher

A



Tirante Ø10
 Ø10 tie
 Verbindungsbolzen Ø10

B



Grano
 Grub screw
 Gewindestift

C



Tappo copriforo Ø12
 Ø12 hole cap
 Verschlusskappe Ø12

D



Regginpiano
 Shelf support
 Einlegebodenträger

E



Barilotto Ø15
 Ø15 bush
 Verbindergehäuse Ø15

F



Tirante M6x27,5
 M6x27,5 tie
 Verbindungsbolzen M6x27,5

G



Spina
 Pin
 Stift

H



Vite TPS Ø3,5x16
 Ø3,5x16 flat head
 countersunk screw
 Schrauben TPS Ø3,5x16

I



Vite TPS Ø4x16
 Ø4x16 flat head
 countersunk screw
 Schrauben TPS Ø4x16

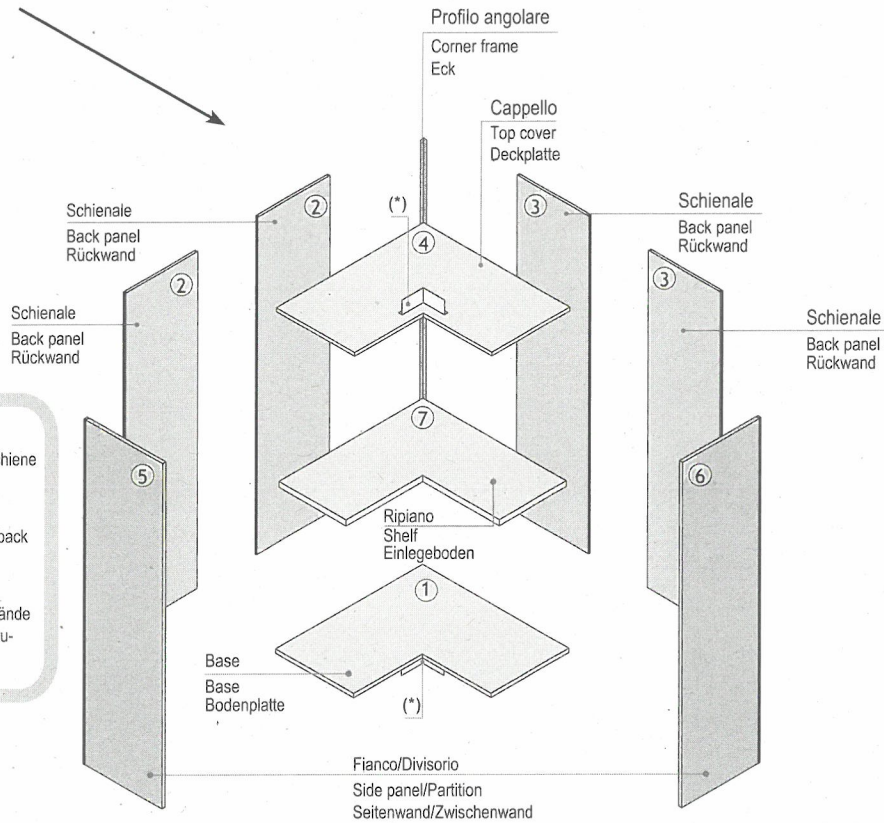
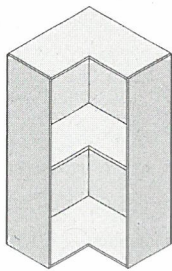

Specifica:
 L'armadio ad angolo scorrevole, presenta 2 schiene in più rispetto al battente/concavo.

Note for sliding doors only:
 The sliding door corner wardrobe has 2 more back panels than its hinged/concave counterpart.

Besonderheit:
 Ein Eckschrank mit Schiebetüren hat 2 Rückwände mehr als ein Eckschrank mit Flügeltüren/abgerundeten Türen.

- (*) Angolare compensatore (solo per angolo scorrevole)
- (*) Filler corner bracket (for sliding doors only)
- (*) Ausgleichswinkelplatte (Besonderheit bei Schiebetüren)

Montaggio dello schienale
 Fitting the back panel
 Montage der Rückwand

1

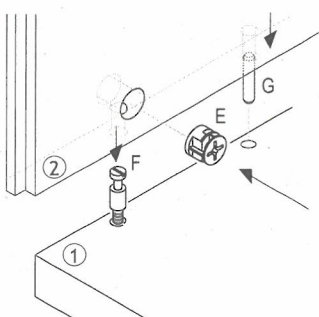

2

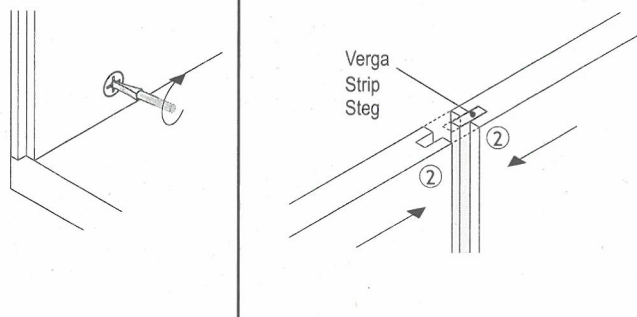

3

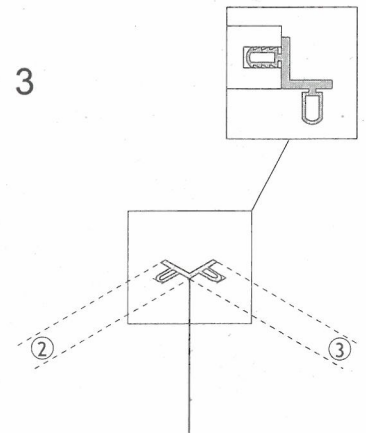

Montaggio della base al fianco
 Fitting the base to the side panel
 Montage der Bodenplatte an der Seitenwand

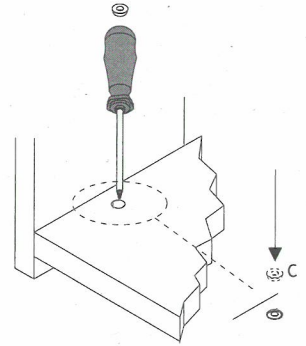
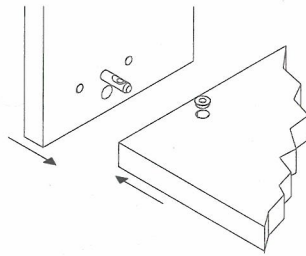
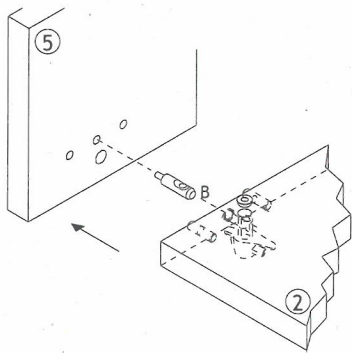

Montaggio del ripiano
 Fitting the shelf
 Montage des Einlegebodens

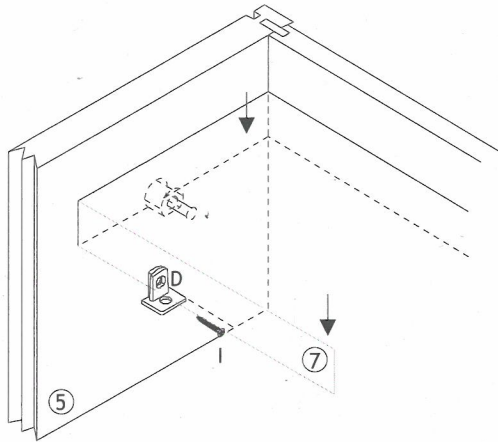

Regolazione
 Adjustment
 Einstellung

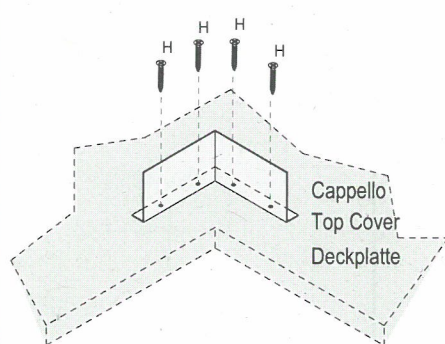
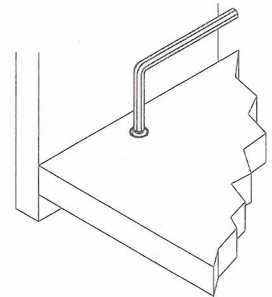

- Montaggio angolare compensatore (specifica per scorrevole)
- Fitting the filler corner bracket (for sliding doors)
- Montage der Ausgleichswinkelplatte (Besonderheit bei Schiebetüren)

Gli angolari compensatori vanno sempre montati prima del montaggio della cabina stessa.
 Filler corner brackets must always be fitted before assembling the actual wardrobe.
 Die Ausgleichswinkelplatten müssen immer vor dem eigentlichen Schrankaufbau montiert werden.

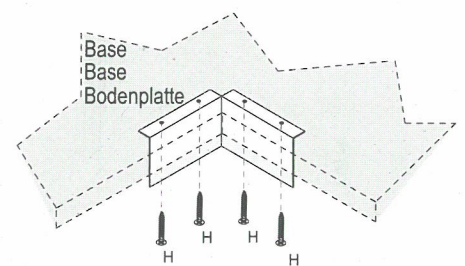

[ITA] PARACOLPI PER ANTE ANGOLO
[ENG] BUFFERS FOR CORNER DOORS
[DEU] ANSCHLAGDÄMPFER FÜR ECKTÜREN



[ITA] L'installazione deve essere eseguita da personale specializzato.
 [ENG] Installation must be carried out by specialized personnel
 [DEU] Ausgebildetem Fachpersonal vorgenommen werden

A



Paracolpi Ø12,5x3
 Ø12,5x3 buffers
 Anschlagdämpfer Ø12,5x3

ATTENZIONE!!! SOLO PER ANTE SPESSORE 22mm
PLEASE NOTE!!! FOR 22mm-THICK DOORS ONLY
ACHTUNG!!! NUR FÜR TÜREN MIT EINER BREITE VON 22mm

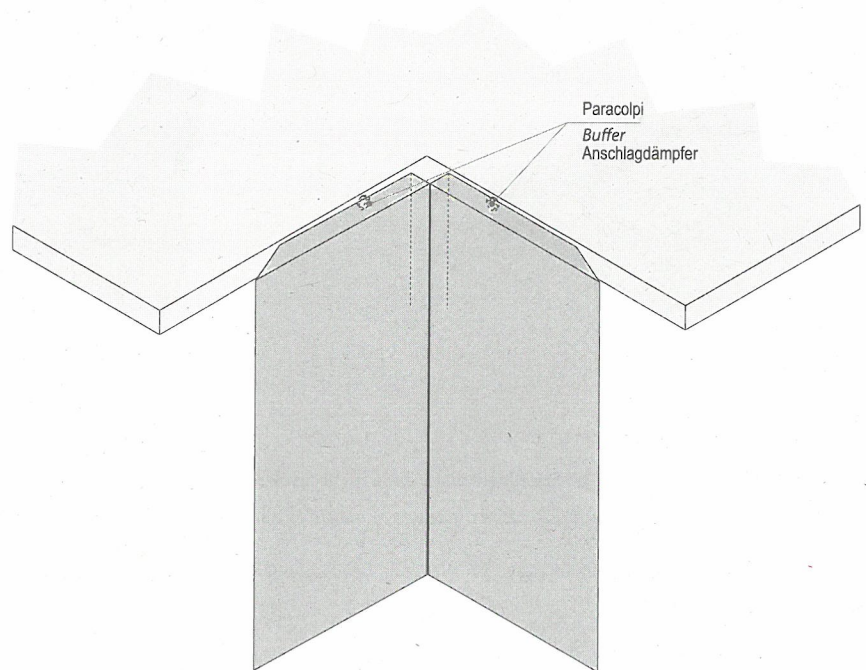
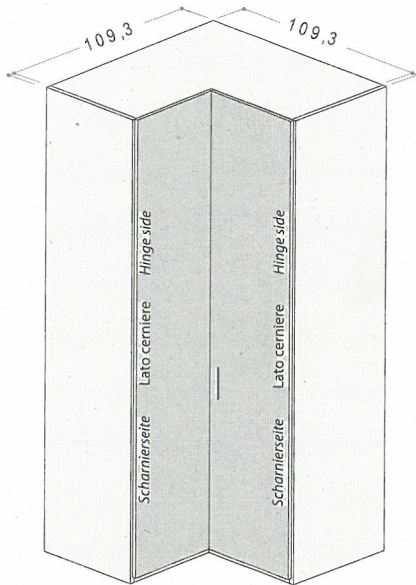

POSIZIONAMENTO PARACOLPI:
 BUFFER POSITIONING:
 POSITIONIERUNG DES ANSCHLAGDÄMPFERS:

Montare il paracolpi come indicato da figura tenendolo a filo anta sulla parte superiore.
 La stessa operazione va effettuato sulla parte inferiore dell'anta.

Fit the buffer as illustrated, keeping it flush with the door at the top.
 You will need to repeat the procedure at the bottom of the door.

Montieren Sie den Anschlagdämpfer, wie in der Abbildung dargestellt, bündig mit der Türoberkante. Führen Sie die gleichen Schritte an der Türunterkante durch.

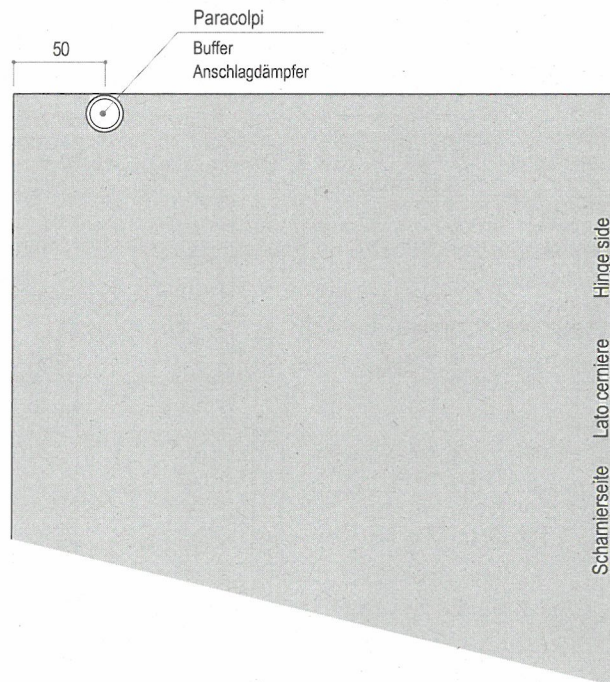

[ITA] ANTA PERRY
 [ENG] PERRY DOOR
 [DEU] TÜR PERRY



[ITA] L'installazione deve essere eseguita da personale specializzato.
 [ENG] Installation must be carried out by specialized personnel
 [DEU] Ausgebildetem Fachpersonal vorgenommen werden

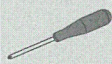

[ITA] Un cacciavite medio a stella
 [ENG] Medium Phillips screwdriver
 [DEU] Mittelgroßer Kreuzschlitzschraubendreher

Fig. 1
 Fig. 1
 Abb. 1

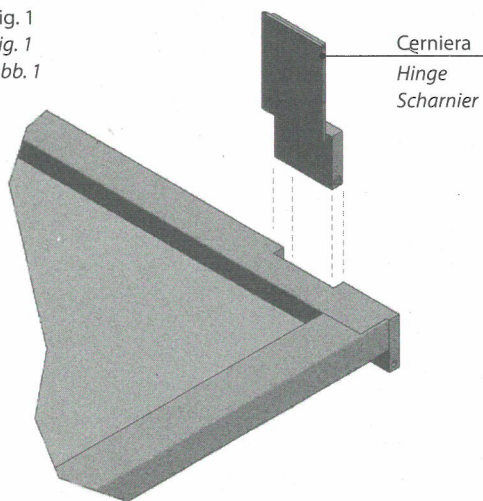
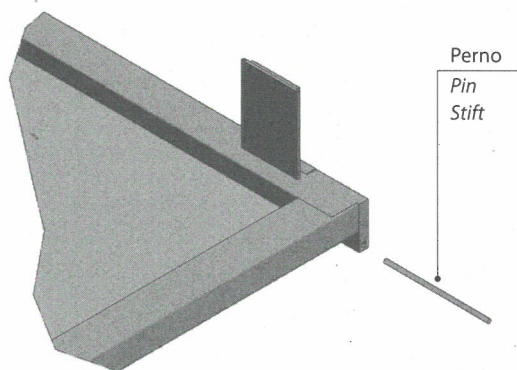

Fig. 2
 Fig. 2
 Abb. 2



1.

Prima di fissare l'anta all'armadio, posizionare il distanziale tra la cerniera e il fianco come in Fig. 3.

Before fastening the door to the wardrobe, place the spacer shown in Fig. 3 between the hinge and the side panel.

Bevor Sie die Tür am Schrank befestigen, fügen Sie bitte zwischen Scharnier und Seitenwand den Abstandshalter ein (siehe Abb. 3).

Fig. 3
 Fig. 3
 Abb. 3

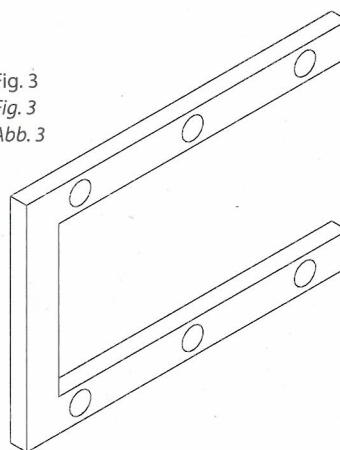

2.

Per la regolazione dell'anta agire nelle 3 viti della cerniera (Fig. 4).

Adjust the door using the 3 screws on the hinge (Fig. 4).

Zur Justierung der Tür drehen Sie bitte an den 3 Einstellschrauben des Scharniers (Abb. 4).

Fig. 4
 Fig. 4
 Abb. 4

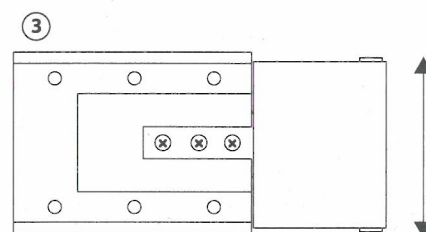
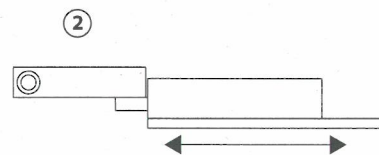
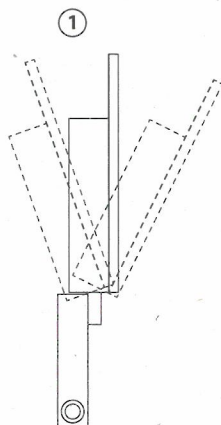
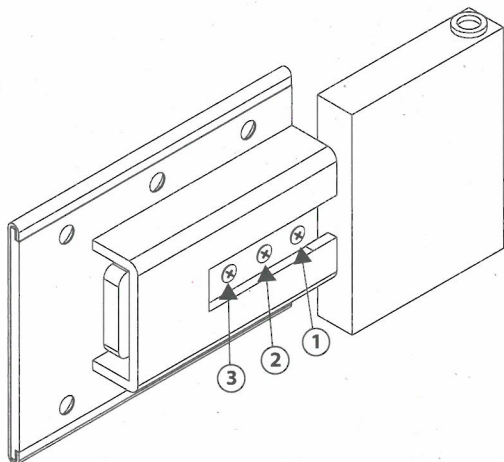

[ITA] ARMADI SCORREVOLI
[ENG] SLIDING DOOR WARDROBES
[DEU] SCHIEBETÜRENSCHRANK



[ITA] L'installazione deve essere eseguita da personale specializzato.
 [ENG] Installation must be carried out by specialized personnel
 [DEU] Ausgebildetem Fachpersonal vorgenommen werden



[ITA] Un cacciavite medio a stella
 [ENG] Medium Phillips screwdriver
 [DEU] Mittelgroßer Kreuzschlitzschraubendreher



A
 Reggiripiano
 Shelf support
 Einlegebodenträger



B
 Tirante Ø10
 Ø10 tie
 Verbindungsbolzen Ø10



C
 Tappo copriforo Ø12
 Ø12 hole cap
 Verschlusskappe Ø12



D
 Fermaschiena
 Back retainer
 Rückwandhalter



E
 Vite TPS Ø3,5x16
 Ø3,5x16 flat head
 countersunk screw
 Schrauben TPS Ø3,5x16

[ITA] I pezzi sono numerati in ordine di montaggio, inoltre devono sempre essere montati da SX verso DX.

[ENG] Parts are numbered in the order they are assembled in. In addition, they must always be fitted from left to right.

[DEU] Die einzelnen Stücke sind entsprechend Der Montagefolge durchnummeriert. Führen Sie die Montage immer von links nach rechts durch.

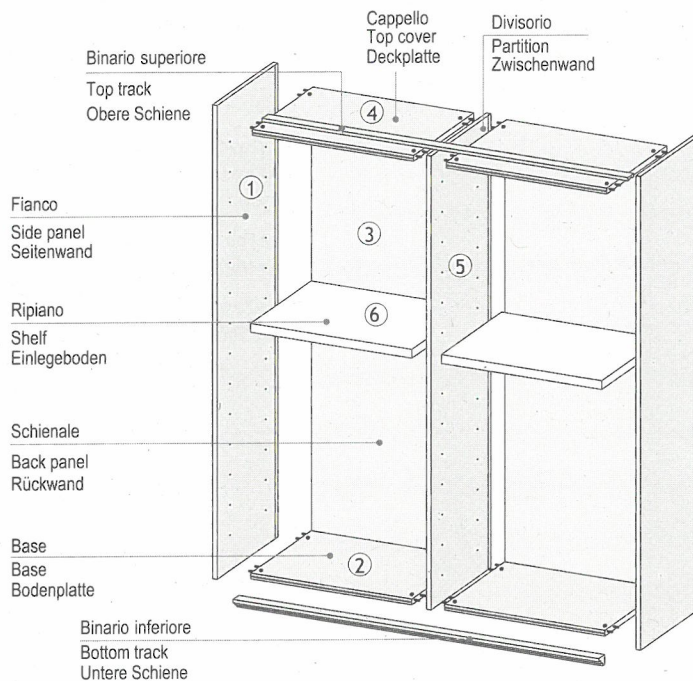

- 1 - Montaggio della base al fianco
 1 - Fitting the base to the side panel
 1 - Montage der Bodenplatte an der Seitenwand

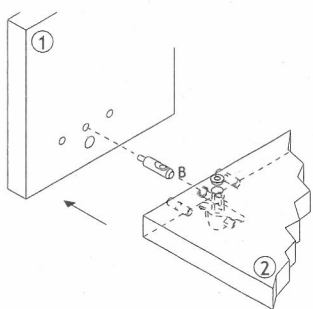

- 2 - Montaggio dello schienale
 2 - Fitting the back panel
 2 - Montage der Rück wand

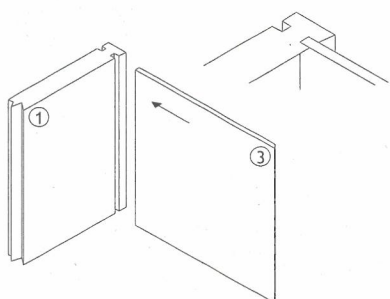

- 3 - Montaggio del ripiano
 3 - Fitting the shelf
 3 - Montage des Einlegebodens

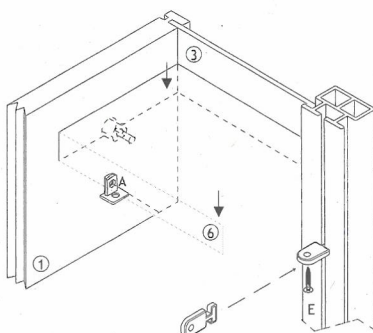

- 4 - Regolazione
 4 - Adjustment
 4 - Einstellung

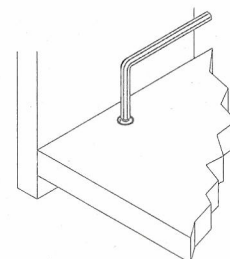

[ITA] MONTAGGIO IN NICCHIA (ARMADIO BATTENTE / SCORREVOLE)

[ENG] ASSEMBLY IN A RECESS (HINGED/SLIDING DOOR WARDROBE)

[DEU] NISCHENMONTAGE (SCHRANK MIT FLÜGEL-/SCHIEBETÜREN)



[ITA] L'installazione deve essere eseguita da personale specializzato.
 [ENG] Installation must be carried out by specialized personnel
 [DEU] Ausgebildetem Fachpersonal vorgenommen werden

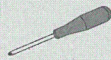

[ITA] Un cacciavite medio a stella
 [ENG] Medium Phillips screwdriver
 [DEU] Mittelgroßer Kreuzschlitzschraubendreher

A

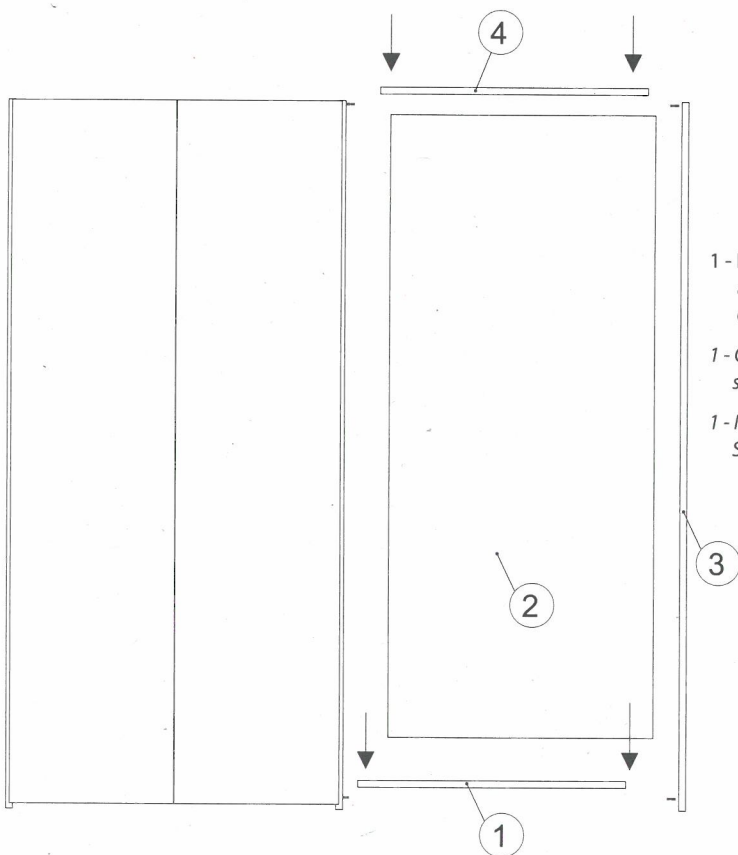
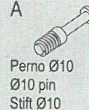

1 - Dopo aver assemblato l'armadio avvitare i perni (A) sui fianchi e divisori.

1 - Once you have assembled the wardrobe, screw the pins (A) into the side panels and partitions.

1 - Nach Zusammenbau des Schrankes verschrauben Sie die Stifte (A) an den Seiten- und Zwischenwänden.

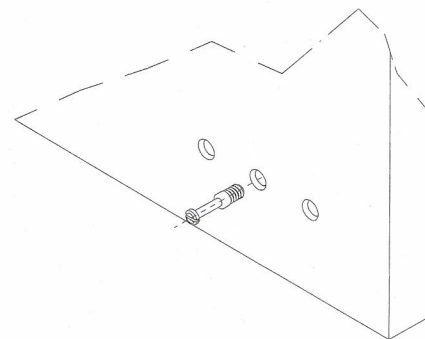
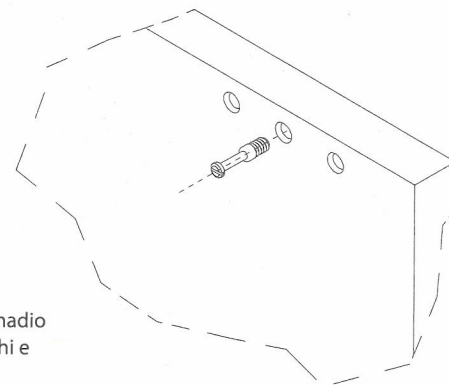

2 - Adagiare da sopra la base, infilare la schiena e accostare il fianco. Avvitare il barilotto annesso nella base e infilare il coperchio bloccandolo internamente.

2 - Move the base into place from above, slot the back panel in and position the side panel. Screw in the bush embedded in the base and slot the top cover on, securing it from inside.

2 - Legen Sie die Bodenplatte von oben ein. Stecken Sie die Rückwand ein und fügen Sie die Seitenwand hinzu. Verschrauben Sie das in die Bodenplatte eingearbeitete Verbindergehäuse und fügen Sie die Deckplatte hinzu. Arretieren Sie diese von innen.

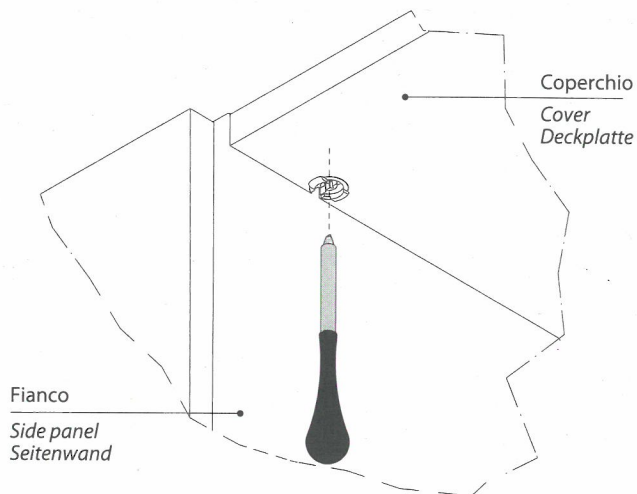

Fianco
 Side panel
 Seitenwand

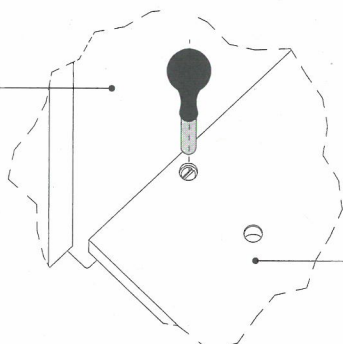

Base
 Base
 Bodenplatte

[ITA] MONTAGGIO IN NICCHIA (ARMADIO SCORREVOLE)

[ENG] ASSEMBLY IN A RECESS (SLIDING DOOR WARDROBE)

[DEU] NISCHENMONTAGE (SCHIEBETÜRENSCHRANK)



[ITA] L'installazione deve essere eseguita da personale specializzato.

[ENG] Installation must be carried out by specialized personnel

[DEU] Ausgebildetem Fachpersonal vorgenommen werden



[ITA] Un cacciavite medio a stella

[ENG] Medium Philips screwdriver

[DEU] Mittelgroßer Kreuzschlitzschraubendreher

A



Squadretta sagomata
Shaped bracket
L-förmige Winkelplatte

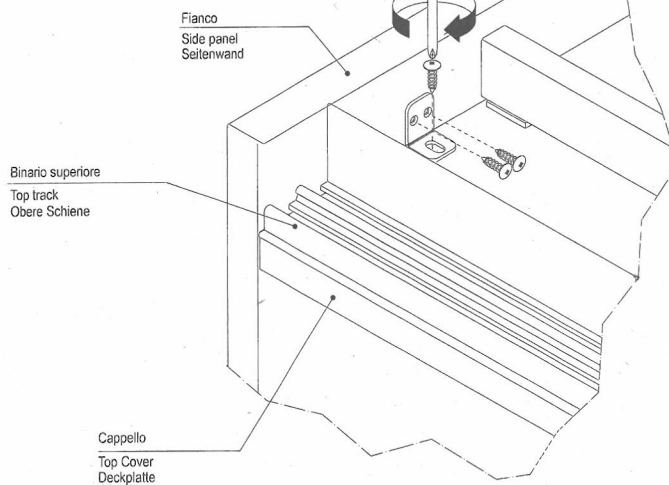
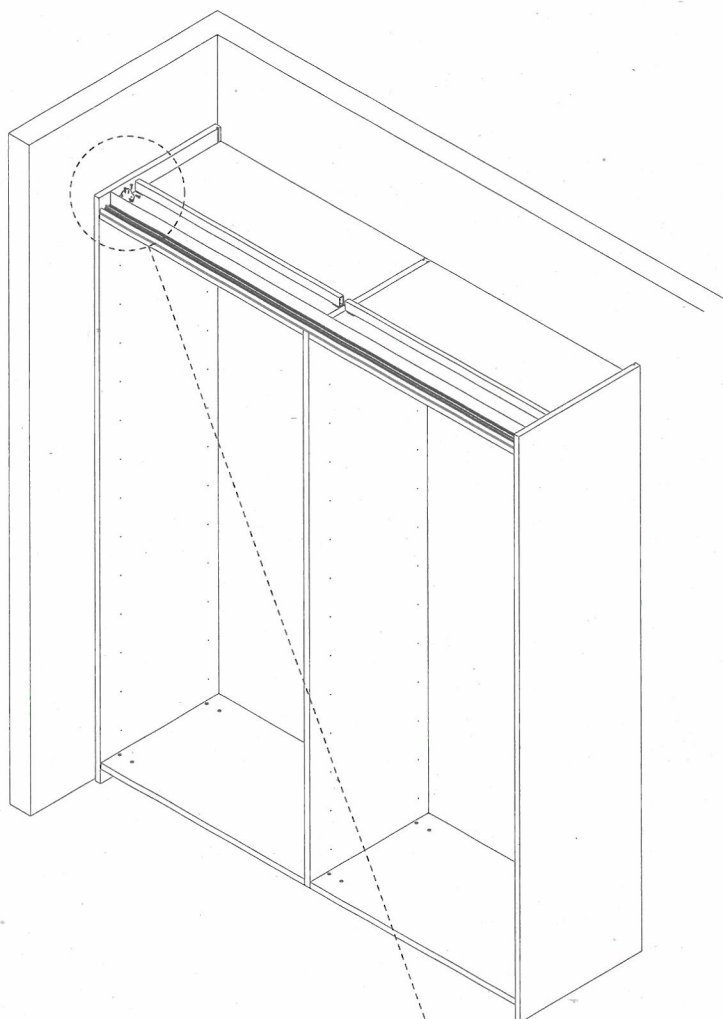

[ITA] BARRA DI RINFORZO PER ARMADIO SCORREVOLE / FISSAGGIO ARMADIO A MURO
[ENG] REINFORCING BAR FOR SLIDING DOOR WARDROBE / FASTENING WARDROBE TO WALL
[DEU] RERSTÄRKUNGSLEISTE FÜR SCHIEBETÜRENSCHRÄNKE / BEFESTIGUNG DES SCHRANKES AN DER WAND



[ITA] L'installazione deve essere eseguita da personale specializzato.
 [ENG] Installation must be carried out by specialized personnel
 [DEU] Ausgebildetem Fachpersonal vorgenommen werden



[ITA] Un cacciavite medio a stella
 [ENG] Medium Phillips screwdriver
 [DEU] Mittelgroßer Kreuzschlitzschraubendreher



A
 Vite TBL M6x35
 M6x35 truss head screw
 Schrauben TBL M6x35



B
 Squadretta sagomata
 Shaped bracket
 L-förmige Winkelplatte



C
 Tassello
 Screwanchor
 Dübel



D
 Vite TPS 4,5x60
 4.5 x 60 flat head counter-sunk screw
 Schrauben TPS 4,5 x 60



E
 Vite TPL 4,2x19
 4.2x19 truss head screw
 Schrauben TBL 4,2x19

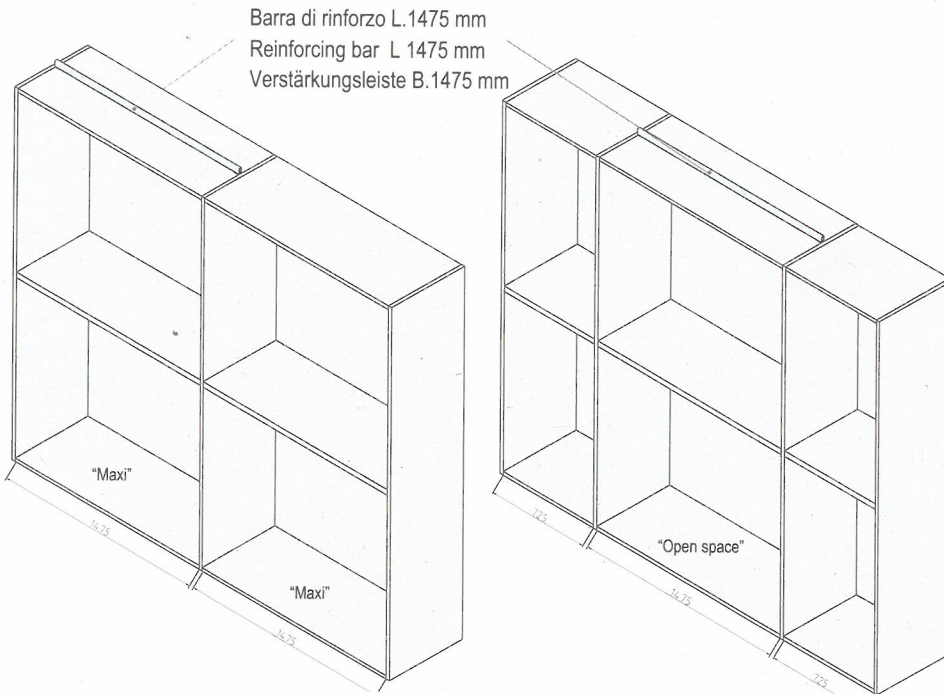

Particolare di fissaggio della barra
 Detail of bar fastening
 Detail der Befestigung der Verstärkungsleiste

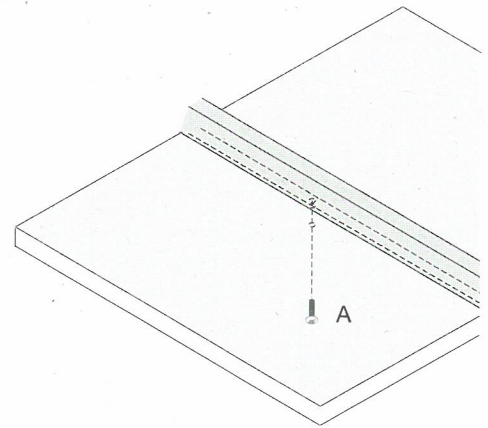

- 1 - In almeno un punto dell'armadio, fissare la squadretta (B) al cappello della composizione (viti E) facendo attenzione che la parte asolata sia sul cappello.
- 1 - Fasten the bracket (B) to the system's top cover (using screws E) in at least one point on the wardrobe, making sure that the side with the slots is on the top cover.
- 1 - Fixieren Sie die Winkel (B) an der Deckplatte der Zusammenstellung (Schrauben E) an wenigstens einem Punkt. Achten Sie darauf, dass der Teil mit dem Langloch an die Deckplatte geschraubt wird.

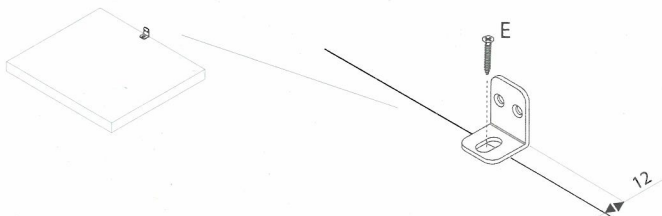

- 2 - Inserire i tasselli (C) nel muro e infine bloccare la squadretta con le viti (D).
- 2 - Insert the screw anchors (C) in the wall and, lastly, secure the bracket with the screws (D).
- 2 - Stecken Sie die Dübel (C) in die Wand und verschrauben Sie den Winkel mit den Schrauben (D).

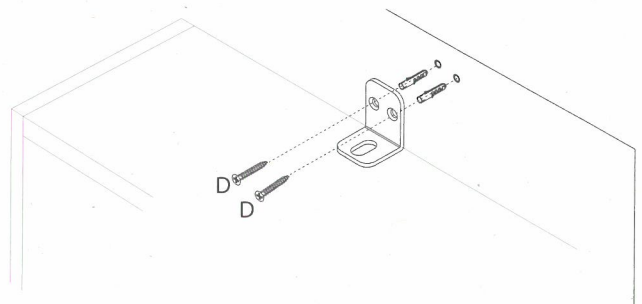

[ITA] REGOLAZIONE ANTA ALFA-GOLA

[ENG] ALFA-GOLA DOOR

[DEU] TÜR ALFA-GOLA



[ITA] L'installazione deve essere eseguita da personale specializzato.

[ENG] Installation must be carried out by specialized personnel

[DEU] Ausgebildetem Fachpersonal vorgenommen werden

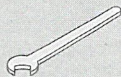

[ITA] Chiave

[ENG] Spanner

[DEU] Schlüssel

- Regolazione delle ante nel caso della presenza dei tenditori raddrizzanti sull'anta. Agire con la chiave in dotazione per regolare l'eventuale curvatura dell'anta, seguendo le istruzioni nel disegno.

- Adjusting doors fitted with door-aligning tensioners. Use the spanner provided to adjust any curve in the door, following the instructions on the drawing.

- Einstellung der Türen bei Vorhandensein von Spannbolzen zur Türausrichtung. Benutzen Sie den beiliegenden Schlüssel wie in der Abbildung dargestellt zum Ausrichten der Tür, falls sie sich verzogen haben sollte oder nicht gerade ist.

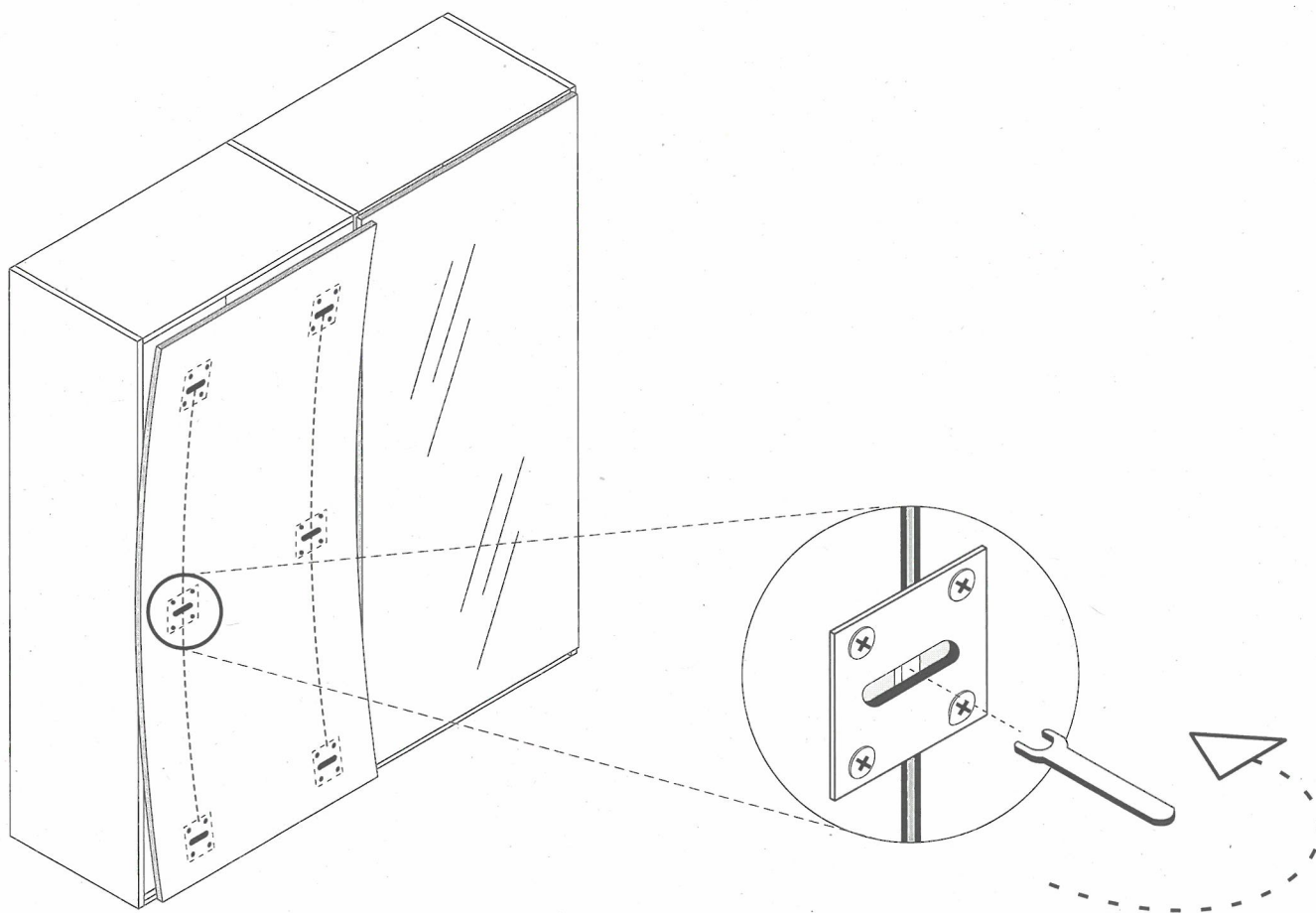

[ITA] ANTA CRYSTAL
[ENG] CRYSTAL DOOR
[DEU] TÜR CRYSTAL



[ITA] L'installazione deve essere eseguita da personale specializzato.
 [ENG] Installation must be carried out by specialized personnel
 [DEU] Ausgebildetem Fachpersonal vorgenommen werden



[ITA] Un cacciavite medio a stella
 [ENG] Medium Phillips screwdriver
 [DEU] Mittelgroßer Kreuzschlitzschraubendreher

A



Vite TPS Ø3,5x16
 Ø3,5x16 flat head countersunk screw
 Schrauben TPS Ø3,5x16

B



Montaggio Ø25 con relativo tirante doppio Ø25 fastener with relevant double-ended rod
 Gehäuse Ø25 mit Doppelbolzen

C



Tappo copriforo Ø25 Ø25 hole cap
 Verschlusskappe Ø25

- 1 - Applicare la ferramenta sui pannelli.
 1 - Fit hardware on the panels.
 1 - Befestigen Sie die Beschläge an den Paneelen.

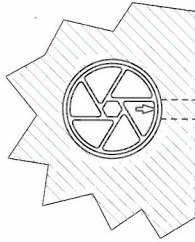

Posizionamento del montaggio:

Inserire sempre il montaggio con la freccia in direzione del foro per il tirante.

Fastener positioning:

Always insert the fastener with the arrow pointing towards the hole for the tie rod.

Positionierung des Gehäuses:

Setzen Sie das Gehäuse so ein, dass der Pfeil in Richtung der Öffnung für den Bolzen zeigt.

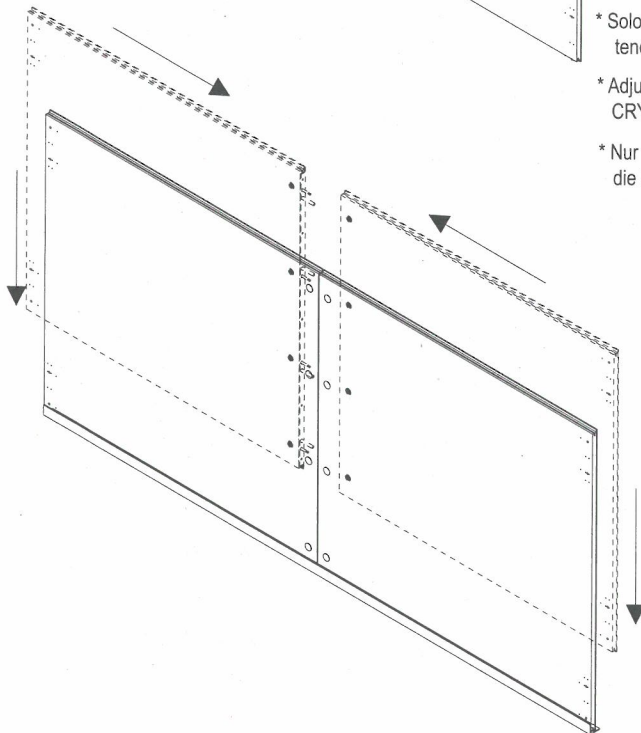
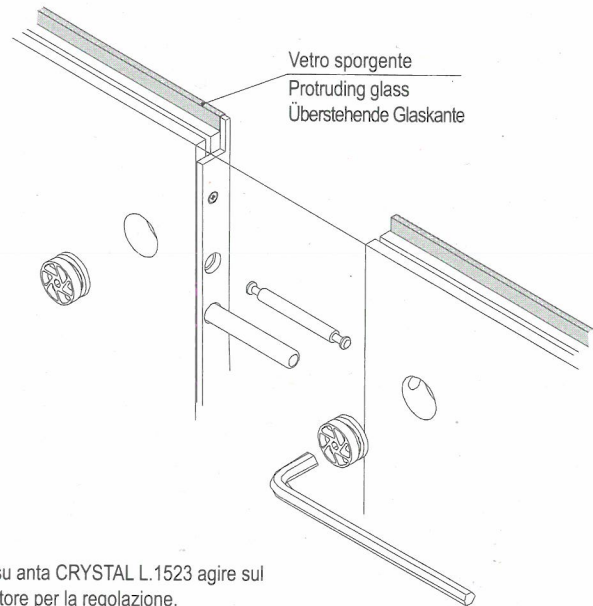
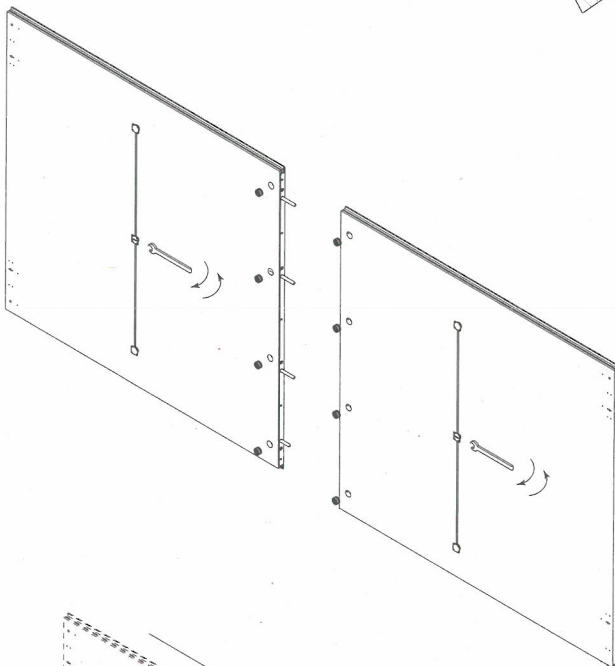

* Solo su anta CRYSTAL L.1523 agire sul tenditore per la regolazione.

* Adjust using the tie rod on 1523cm-wide CRYSTAL door only.

* Nur bei Tür CRYSTAL B.1523: Bitte verwenden Sie die Zugbolzen zur Türausrichtung für die Einstellung.

2 - Porre il profilo a terra e adagiarsi sopra con delicatezza i pannelli sino all'innesto completo del profilo.
 Congiungere i pannelli e avvitare gli eccentrici tramite la chiave a brugola data in dotazione.

2 - Place the profile on the ground and gently sit the panels on top until they slot all the way in.
 Join the panels together and tighten the eccentric fasteners using the Allen key provided.

2 - Legen Sie das Profil auf den Boden.
 Stellen Sie dann die Paneele vorsichtig so auf ihm ab, dass es vollständig in die Paneele einrasten.
 Verbinden Sie die Türpaneele und ziehen Sie die Exzenterschrauben mit dem beiliegenden Inbusschlüssel fest.

- 3 - Avvitare le apposite viti lungo i profili laterali.
- 3 - Screw in the relevant screws along the side profiles.
- 3 - Setzen Sie die Schrauben entlang der seitlichen Profile.

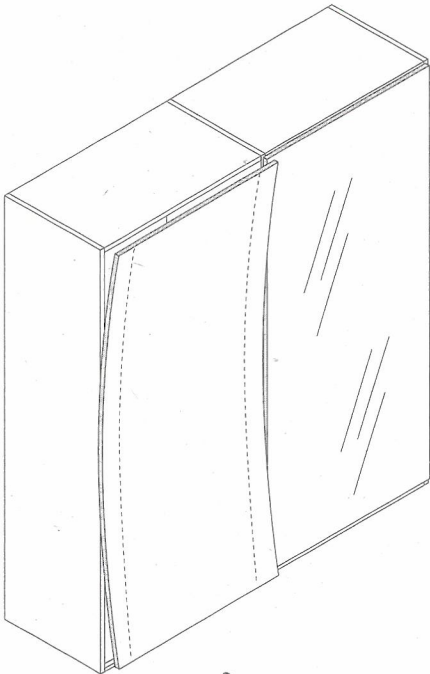
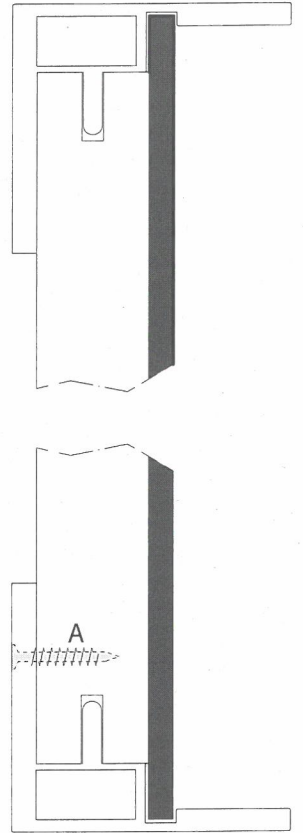
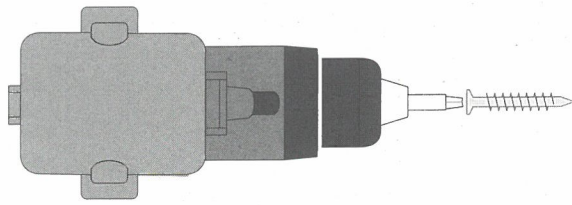
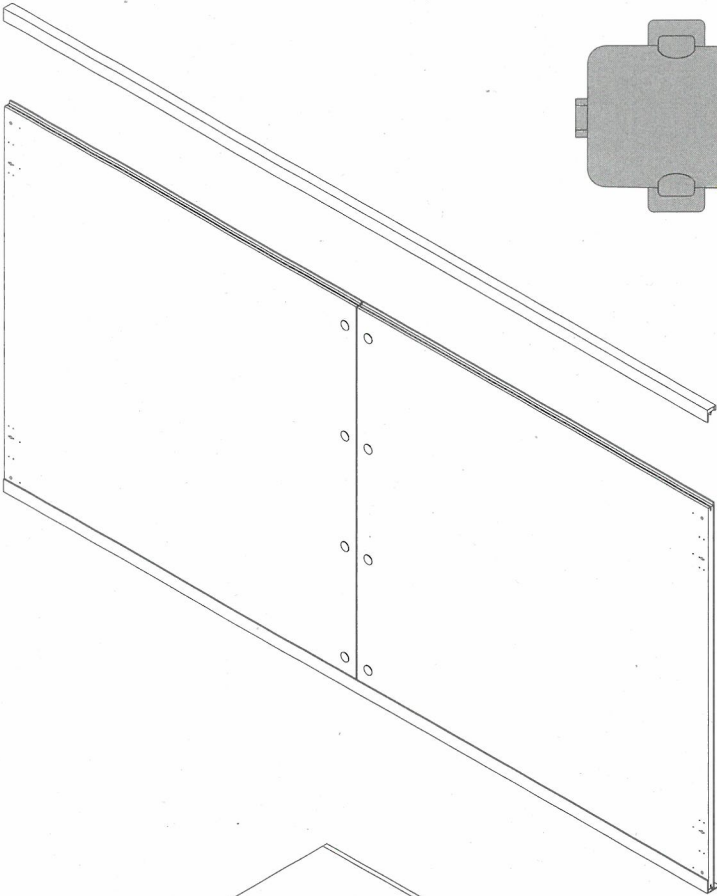

PARTICOLARE A
DETAIL A
DETAILANSICHT A

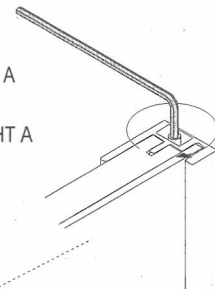

Agire qui
Adjust here
Hier drehen

Agire qui
Adjust here
Hier drehen

Agire con la chiave a brugola (D) in dotazione per regolare l'eventuale curvatura dell'anta, agendo nella parte superiore della stessa (vedi particolare A).

Use the Allen key (D) provided to adjust any curve in the door, inserting it in the top of the door and turning (see detail A).

Richten Sie mit dem beiliegenden Inbusschlüssel (D) die Tür aus, falls sie sich verzogen haben sollte oder nicht gerade ist. Drehen Sie dazu an der Türoberseite (siehe Detailansicht A).

PARTICOLARE A
DETAIL A
DETAILANSICHT A

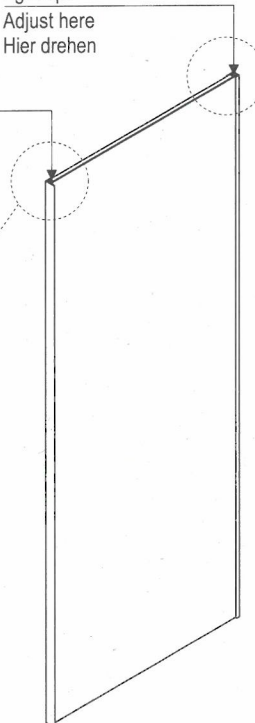
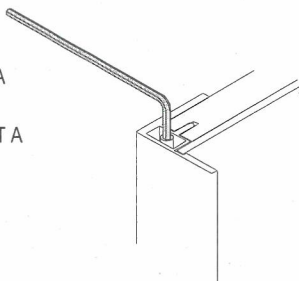

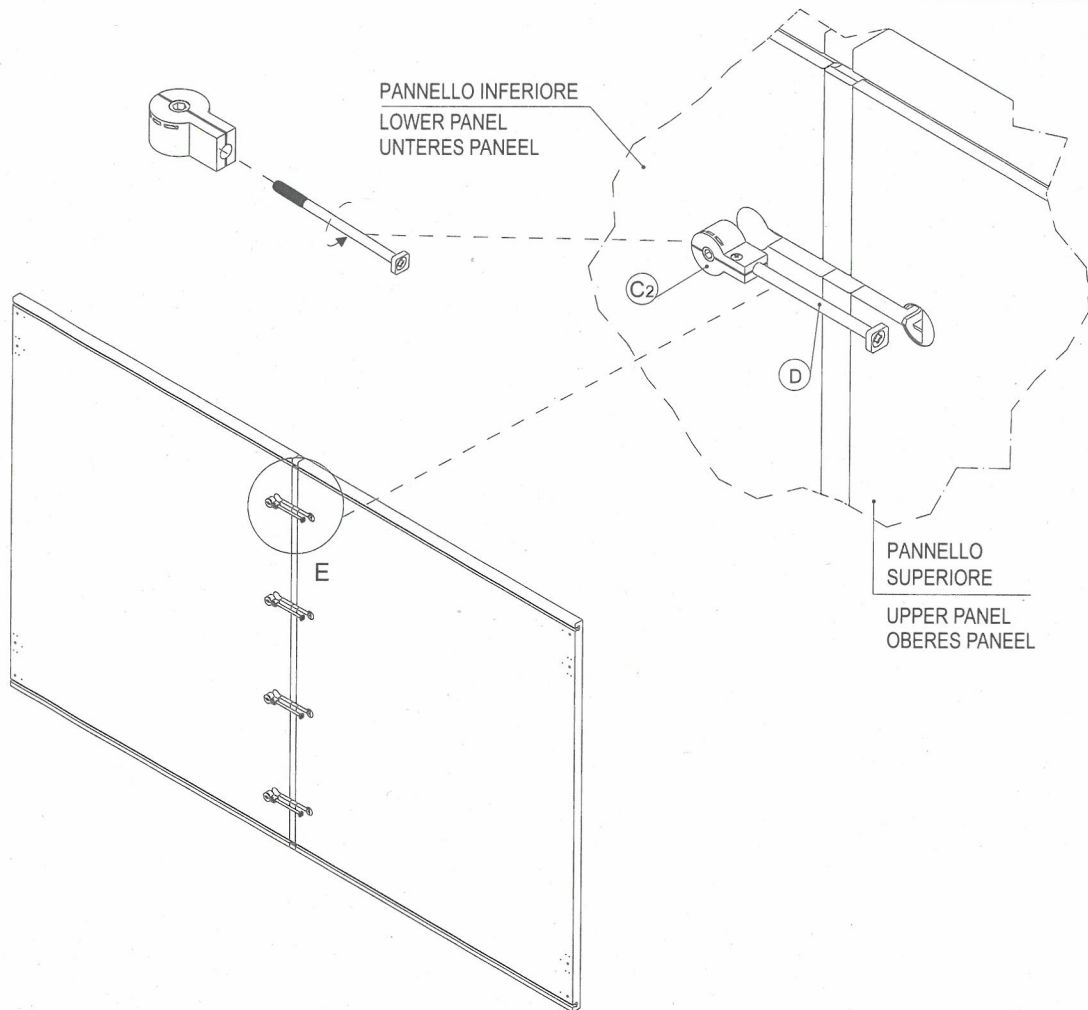

NON CHIUDERE IL MONTAGGIO, ma traslare i due tiranti nelle apposite sedi facendo ATTENZIONE che la regolazione dell'anta sia nella parte superiore della stessa (particolare A). Una volta posizionato i tiranti chiudere il tutto con la chiave a brugola (A).

DO NOT TIGHTEN THE FITTING ALL THE WAY, instead run the tie rods along the relevant channels, MAKING SURE that the door's adjustment system is at the top (detail A). Once the tie rods are in place, use the Allen key (A) to tighten up the resulting door.

SCHLIESSEN SIE DEN PLATTENVERBINDER NOCH NICHT! Schieben Sie die zwei Spanner in ihren Sitz. ACHTEN Sie dabei darauf, dass die Regelschrauben zur Türeinrichtung nach oben zeigen (Detailansicht A). Wenn die Spanner ihren korrekten Sitz haben, ziehen Sie sie mit dem Inbusschlüssel (A) fest.

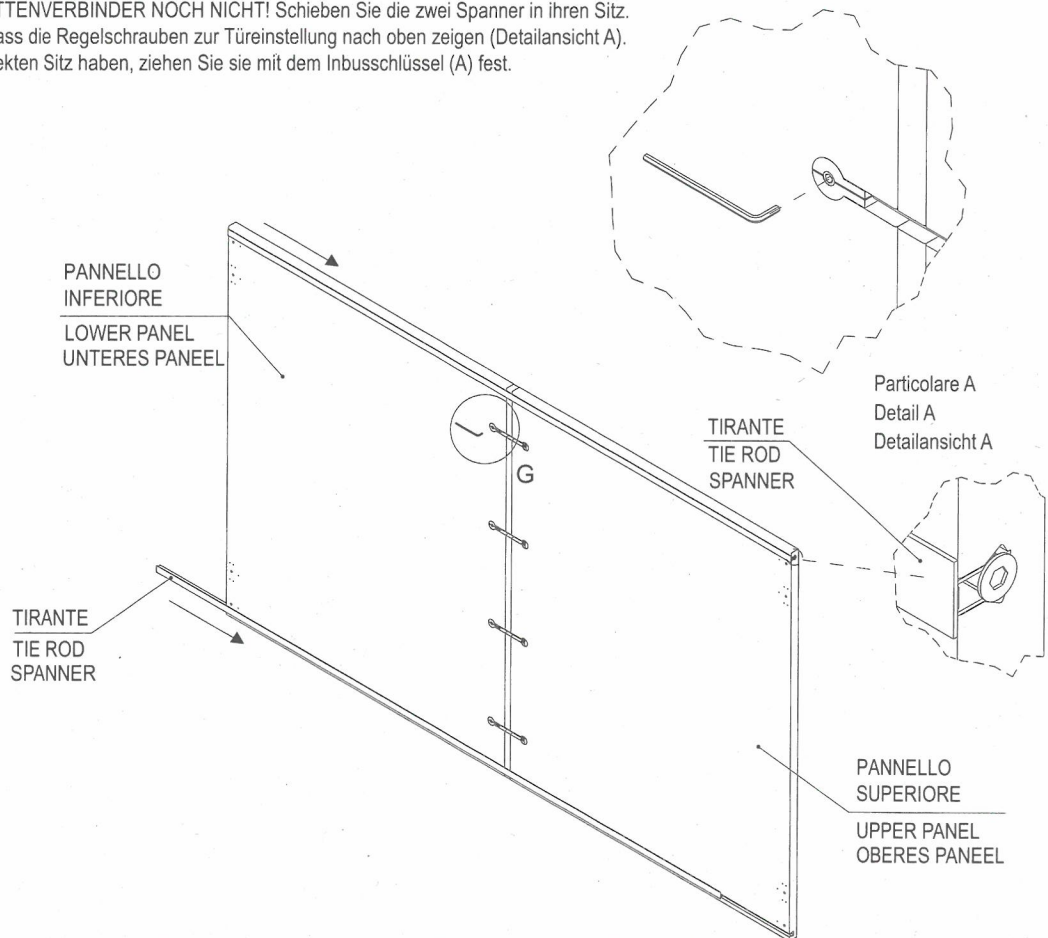

[ITA] ANTA OFFSET
[ENG] OFFSET DOOR
[DEU] TÜR OFFSET



[ITA] L'installazione deve essere eseguita da personale specializzato.
[ENG] Installation must be carried out by specialized personnel
[DEU] Ausgebildetem Fachpersonal vorgenommen werden



[ITA] Chiave
[ENG] Allen key
[DEU] Inbusschlüssel



Vite TPS 6Mx15
M6x15 flat head
countersunk screw
Schrauben TPS 6Mx15

- 1 - Collegare i 2 pannelli utilizzando l'inserto a doppia T premontato. Inserire con cura, fino in fondo.
1 - Connect the 2 panels using the double-T insert that comes ready fitted. Carefully insert all the way in.
1 - Verbinden Sie die beiden Paneele mit dem vormontierten T-förmigen Verbindungsprofil. Schließen Sie die Verbindung sorgfältig und vor allem vollständig.

- 2 - Controllare attentamente che i pannelli siano allineati frontalmente e lateralmente.
2 - Carefully check that the panels are aligned both at the front and sides.
2 - Stellen Sie sicher, dass die Paneele von vorn und von der Seite bündig schließen.

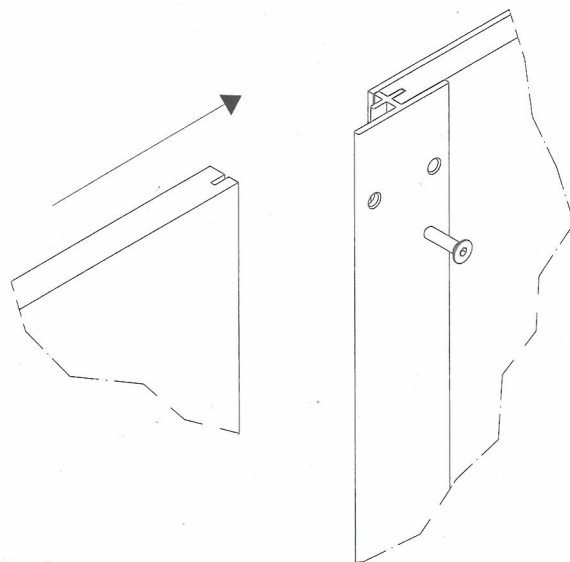
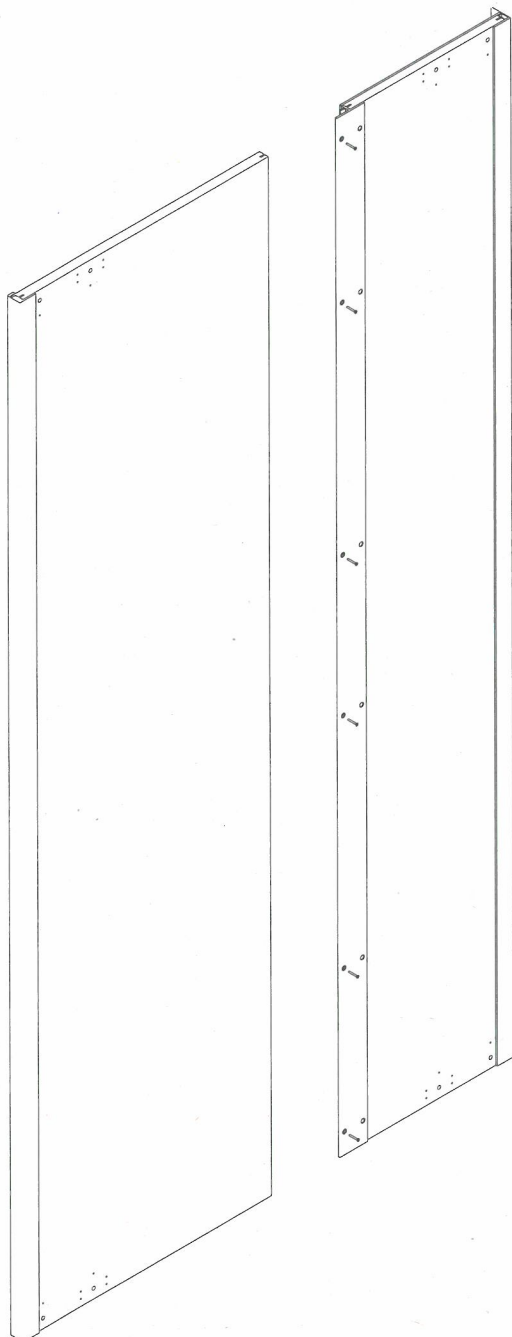

- 3 - Usare le viti 6Mx15 con una chiave esagonale n°4 per bloccare l'unione dei 2 pannelli.
3 - Using the M6x15 screws, secure the 2 panels together with the aid of the 4mm Allen key.
3 - Verwenden Sie die Schrauben 6Mx15 und den 4mm-Inbusschlüssel, um die Verbindung der beiden Paneele zu arretieren.

[ITA] ANTA ALLISON
 [ENG] ALLISON DOOR
 [DEU] TÜR ALLISON



[ITA] L'installazione deve essere eseguita da personale specializzato.
 [ENG] Installation must be carried out by specialized personnel
 [DEU] Ausgebildetem Fachpersonal vorgenommen werden



[ITA] Un cacciavite medio a stella
 [ENG] Medium Phillips screwdriver
 [DEU] Mittelgroßer Kreuzschlitzschraubendreher

A

 Vite TBL 4.2x19
 TBL 4.2x19 screw
 Schrauben TBL 4.2x19

- 1 - Applicare il profilo intermedio al pannello (Fig. 1) con le viti in dotazione (viti A).
- 1 - Fit the intermediate profile on the panel (Fig. 1) using the screws provided (screws A).
- 1 - Befestigen Sie das mittlere Profil am Paneel (Abb. 1). Verwenden Sie dazu die beiliegenden Schrauben (A).

- 2 - Unire i pannelli inferiore e superiore e bloccarli con i tiranti (Fig. 2).
- 2 - Join the lower and upper panels together and secure in place with the tie rods (Fig. 2).
- 2 - Fügen Sie das untere und das obere Paneel zusammen und arretieren Sie beide mit den Verbindungsbolzen (Abb. 2).

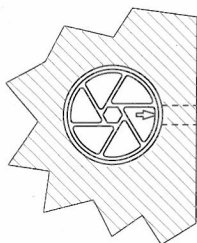

Posizionamento del montaggio:

Inserire sempre il montaggio con la freccia in direzione del foro per il tirante.

Fastener positioning:

Always insert the fastener with the arrow pointing towards the hole for the tie rod.

Positionierung des Gehäuses:

Setzen Sie das Gehäuse so ein, dass der Pfeil in Richtung der Öffnung für den Bolzen zeigt.

- 3 - Inserire la gola laterale e fissarla con le viti (A) al pannello (Fig. 3).
- 3 - Insert the side profile and fasten it to the panel with the screws (A) (Fig. 3).
- 3 - Fügen Sie die seitliche Griffille hinzu und arretieren Sie sie mit den Schrauben (A) am Paneel (Abb. 3).

PARTICOLARE
 DETAIL
 DETAILANSICHT

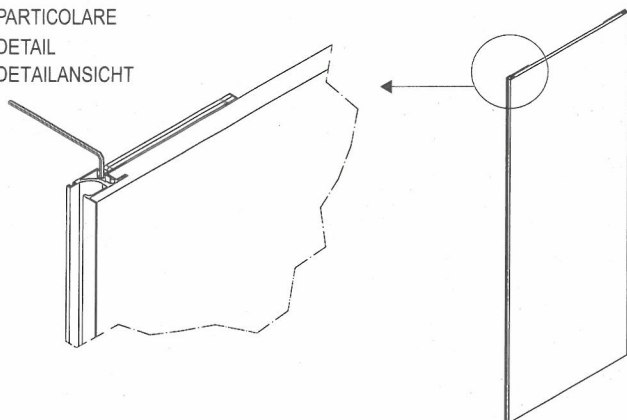

Fig. 1
 Fig. 1
 Abb. 1

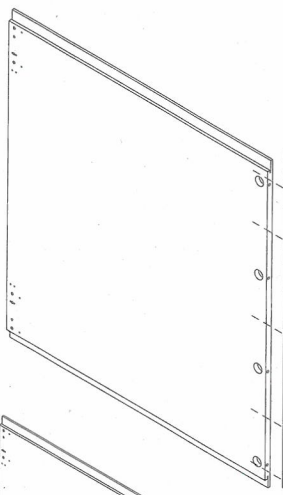

Fig. 2
 Fig. 2
 Abb. 2

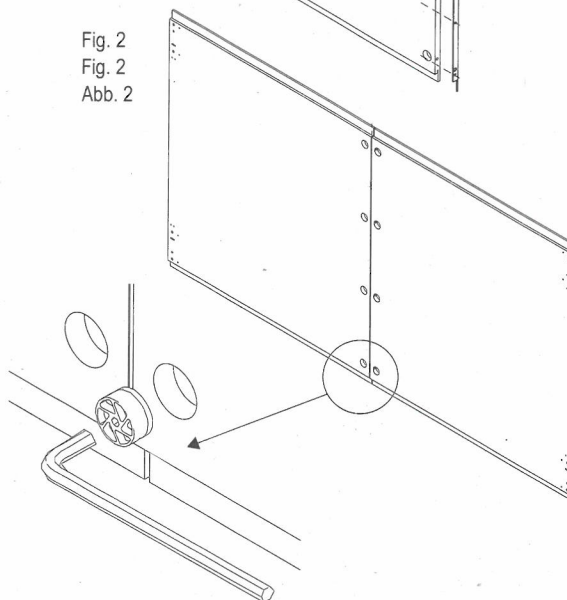
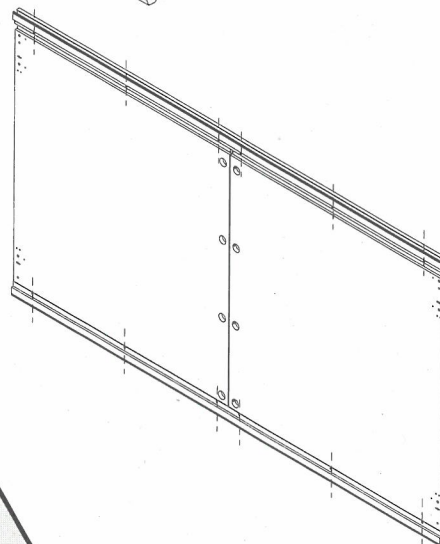

Fig. 3
 Fig. 3
 Abb. 3



- 4 - Per il fissaggio dei carrelli usare le viti 4x30 che si trovano nella scatola ferramenta e non quelle in dotazione con i carrelli.
- 4 - To fasten the runners, use the 4x30 screws, which you will find in the hardware box, not the ones provided with the actual runners.
- 4 - Verwenden Sie zur Montage der Gleitschuhe die Schrauben 4x30 aus der Beschlägeschachtel und nicht die dem Gleitschuh beiliegenden Schrauben.

[ITA] ANTA PICTURE
 [ENG] PICTURE DOOR
 [DEU] TUR PICTURE



[ITA] L'installazione deve essere eseguita da personale specializzato.

[ENG] Installation must be carried out by specialized personnel

[DEU] Ausgebildetem Fachpersonal vorgenommen werden



[ITA] Un cacciavite medio a stella

[ENG] Medium Phillips screwdriver

[DEU] Mittelgroßer Kreuzschlitzschraubendreher

A



Vite TSP M6x16
 M6x16 flat head countersunk screw
 Schrauben TSP M6x16

- 1 - Appoggiare il pannello inferiore a terra come in Fig. 1.
- 1 - Sit the lower panel on the ground as shown in Fig. 1.
- 1 - Stellen Sie das untere Paneel auf den Boden (siehe Abb. 1).

Attenzione: avere cura di appoggiare il pannello non direttamente sul pavimento per evitare di rovinare l'anta.

Please note: make sure you don't sit the panel directly on the floor so as not to damage the door.

Achtung: Achten Sie darauf, dass das Paneel nicht direkt auf dem Fußboden steht, damit die Tür nicht beschädigt wird.

Fig. 1
 Fig. 1
 Abb. 1

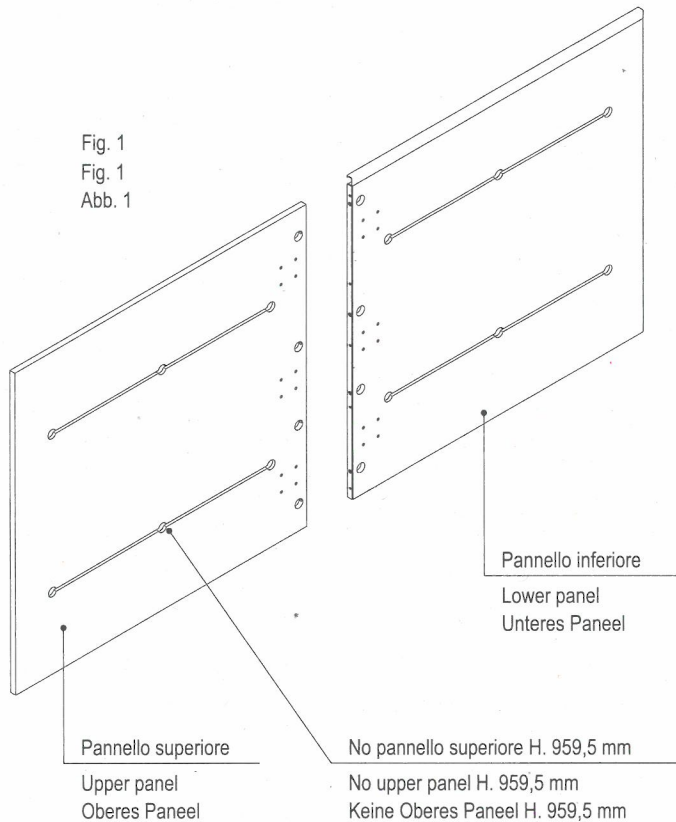

- 2 - Collegare il pannello superiore al pannello inferiore tramite i tiranti in confezione (Fig.2).
 Abbinare i pannelli inferiori SX-DX ai rispettivi pannelli superiori SX-DX.

- 2 - Connect the upper panel to the lower panel using the tie rods in the box (Fig.2).
 Match the lower panels LH-RH to their respective upper panels LH-RH.

- 2 - Verbinden Sie das obere und das untere Paneel mit den mitgelieferten Verbindungsbolzen (Abb. 2).
 Sichern Sie die unteren Panel LI-RE an die jeweiligen oberen Panel LI-RE.

Fig. 2
 Fig. 2
 Abb. 2

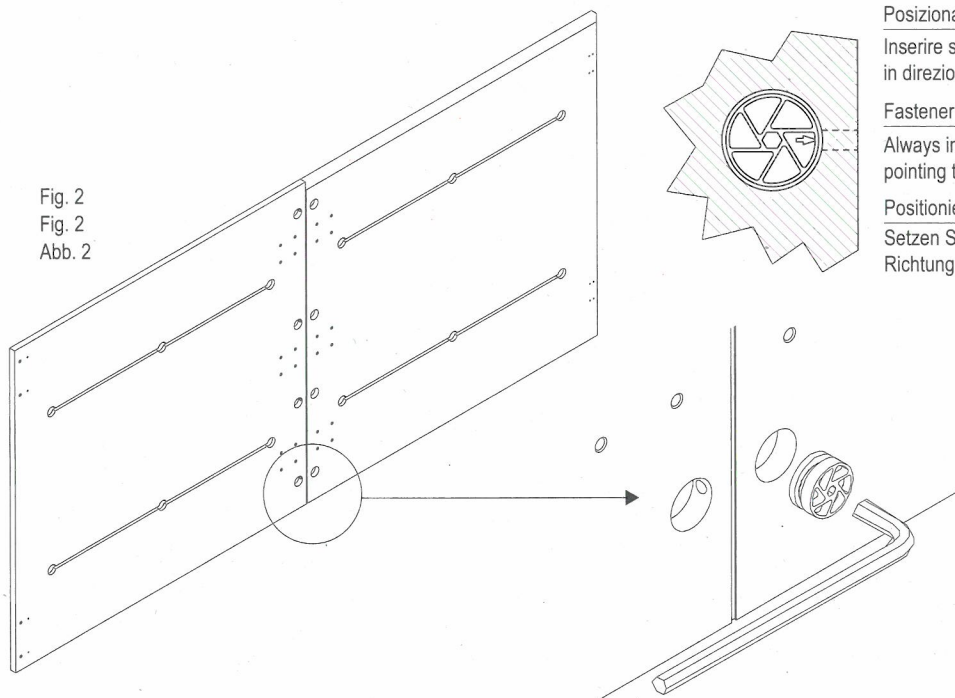

Posizionamento del montaggio:

Inserire sempre il montaggio con la freccia in direzione del foro per il tirante.

Fastener positioning:

Always insert the fastener with the arrow pointing towards the hole for the tie rod.

Positionierung des Gehäuses:

Setzen Sie das Gehäuse so ein, dass der Pfeil in Richtung der Öffnung für den Bolzen zeigt.

3 - Avvitare le piastre all'anta (Fig. 3) con le viti 6Mx15.

3 - Screw the plates onto the door (Fig. 3) using the M6x15 screws.

3 - Schrauben Sie die Grundplatte mit den Schrauben 6Mx15 an der Tür fest (Abb. 3).

Fig. 3
Fig. 3
Abb. 3

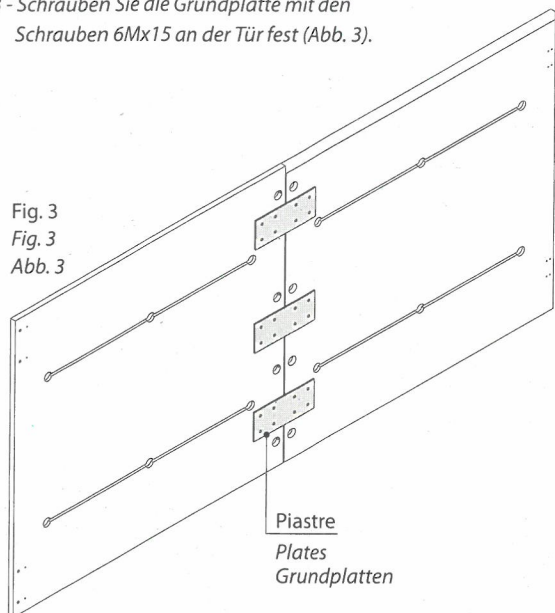

4 - Raddrizzare l'anta come in Fig. 4 per applicarla alla scocca.

4 - Sit the door upright as shown in Fig. 4 so that you can fit it to the carcass.

4 - Richten Sie die Tür auf (wie in Abb. 4 dargestellt) und befestigen Sie sie am Schrank.

Fig. 4
Fig. 4
Abb. 4

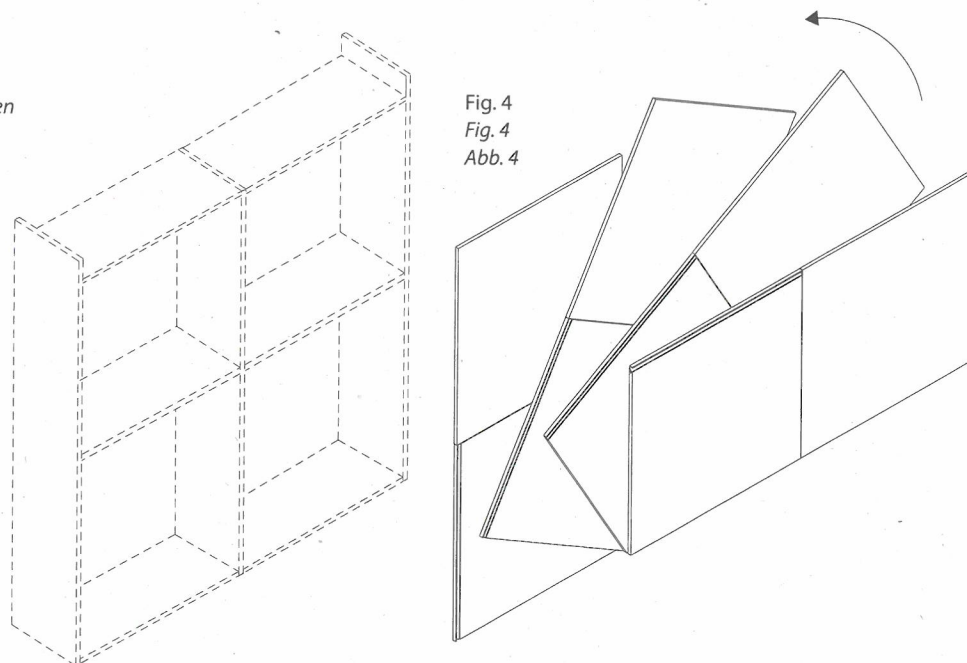

5 - Regolazione delle ante.

Agire con la chiavetta in dotazione per regolare l'eventuale curvatura dell'anta, seguendo le istruzioni nel disegno.

5 - Door adjustment.

Use the spanner provided to adjust any curve in the door, following the instructions on the drawing.

5 - Einstellung der Tür. Benutzen Sie den beiliegenden

Schlüssel wie in der Abbildung dargestellt zum Ausrichten der Tür, falls sie nicht gerade sein sollte.

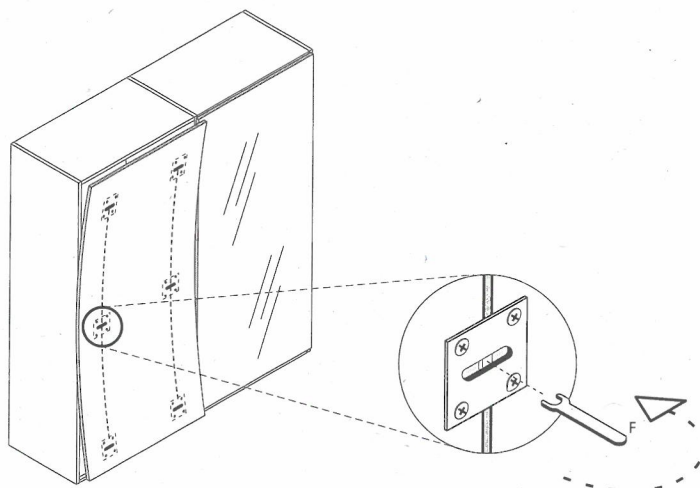

Gli sbalzi termici possono provocare l'incurvamento dell'anta, è necessario, quindi, un periodico intervento di regolazione sui tiranti (ogni 6 mesi).
N.B.: Intervento da effettuare anche prima del montaggio.

Sudden changes in temperature can cause the door to warp, meaning it needs to be adjusted with the ties at regular intervals (every 6 months).
NB: This operation should also be performed prior to assembly.

Bei großen Temperaturschwankungen kann sich die Schiebtür verziehen. Sie muss daher in halbjährlichen Abständen neu ausgerichtet werden.
ANM.: Das Ausrichten und Spannen der Tür sollte auch vor der Montage durchgeführt werden.

[ITA] ANGOLO SPOGLIATOIO

[ENG] WALK-IN CLOSETS

[DEU] BEGEBBARER SCHRANK



[ITA] L'installazione deve essere eseguita da personale specializzato.

[ENG] Installation must be carried out by specialized personnel
[DEU] Ausgebildetem Fachpersonal vorgenommen werden



[ITA] Un cacciavite medio a stella

[ENG] Medium Phillips screwdriver
[DEU] Mittelgroßer Kreuzschlitzschraubendreher



Reggiriporto
Shelf support
Einlegebodenträger



Vite TPS Ø3,5x25
Ø3,5x25 flat head countersunk screw
Schrauben TPS Ø3,5x25

[ITA] I pezzi sono numerati in ordine di montaggio, inoltre devono sempre essere montati da SX verso DX.

[ENG] Parts are numbered in the order they are assembled in. In addition, they must always be fitted from left to right.

[DEU] Die einzelnen Stücke sind entsprechend Der Montagefolge durchnummeriert. Führen Sie die Montage immer von links nach rechts durch.

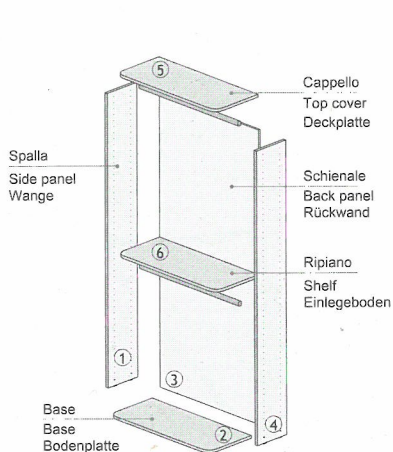

Assemblaggio schiene
Fitting back panels
Zusammenbau der Rückwände

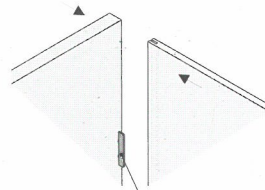

Fermaschiena già montato sul fianco.

Back retainer ready fitted on side panel.

Bereits an der Seitenwand vormontierte Rückwandhalterung.

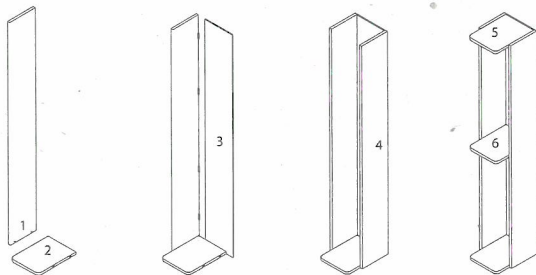

In una composizione è sempre meglio cominciare l'assemblaggio dall'angolo.

When dealing with multiple units in a composition, it is always best to start assembly with the corner unit.

Bei einer Zusammenstellung sollte man beim Zusammenbau immer mit der Ecke beginnen.

Montaggio profilo per schiene angolo
Fitting the profile for corner back panels
Montage des Profils für Eck-Rückwände

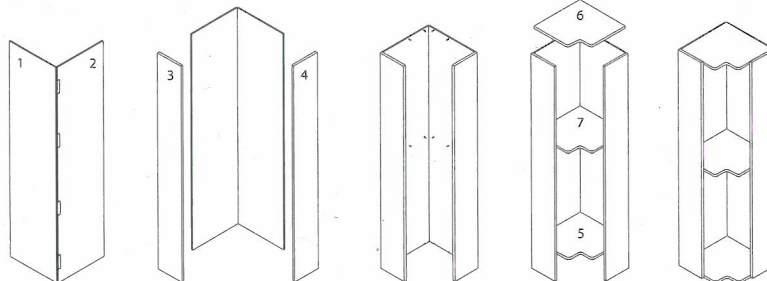
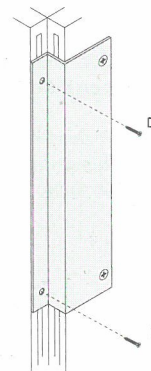
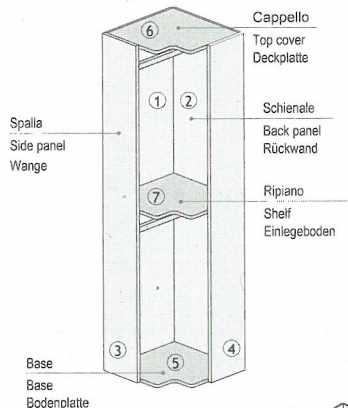

[ITA] POSIZIONAMENTO ANTA RIPOSTIGLIO/CABINA

[ENG] WALK-IN CUPBOARD/CLOSET DOOR POSITIONING

[DEU] POSITIONIERUNG DER TÜREN FÜR ABSTELLRÄUME/BEGEHBARE SCHRÄNKE



[ITA] L'installazione deve essere eseguita da personale specializzato.

[ENG] Installation must be carried out by specialized personnel

[DEU] Ausgebildetem Fachpersonal vorgenommen werden



[ITA] Un cacciavite medio a stella

[ENG] Medium Phillips screwdriver

[DEU] Mittelgroßer Kreuzschlitzschraubendreher

A - Fissare l'anta al fianco con basette sul lato esterno

B - Applicare il profilo sotto-anta alla quota indicata

A - Fasten the door to the side panel with the hinge bases on the outside

B - Apply the under-door profile at the height indicated

A - Befestigen Sie die Tür an der Seitenwand mit den Grundplatten auf der Außenseite

B - Bringen Sie das Staubschutzprofil für die Türunterseite an der vorgegebenen Höhe an.

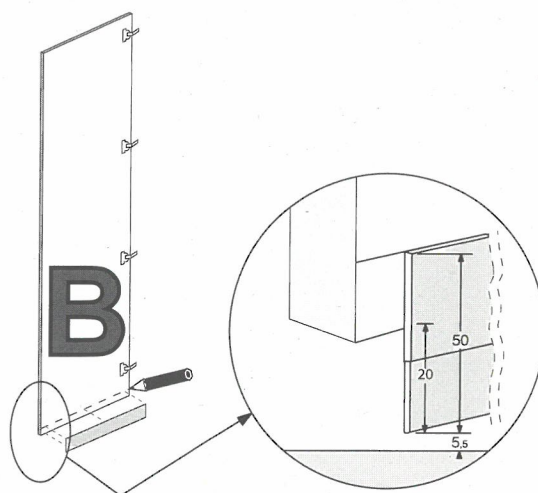
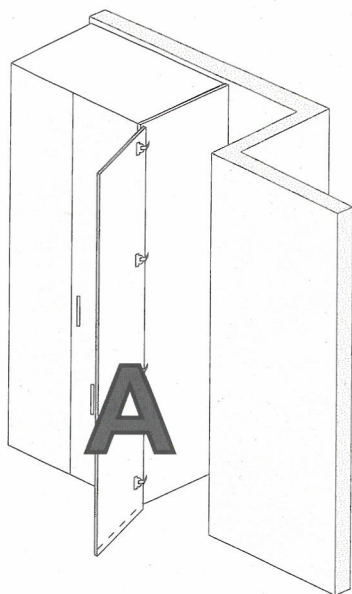

A - Fissare le ante ai fianchi o ai montanti

B - Applicare i profili sotto-anta alla quota indicata

A - Fasten the doors to the side panels or uprights

B - Apply the under-door profiles at the height indicated

A - Befestigen Sie die Tür an den Seitenwänden oder Pfosten

B - Bringen Sie das Staubschutzprofil für die Türunterseite an der vorgegebenen Höhe an.

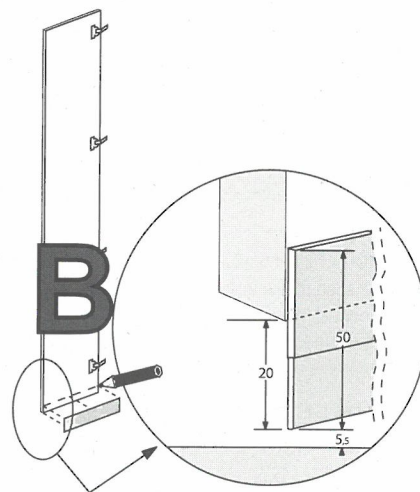
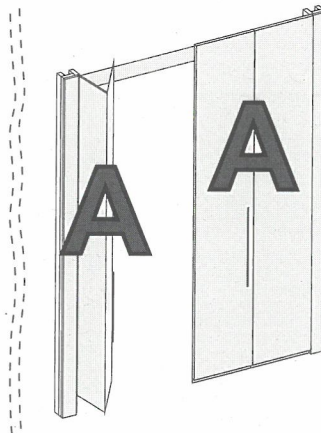
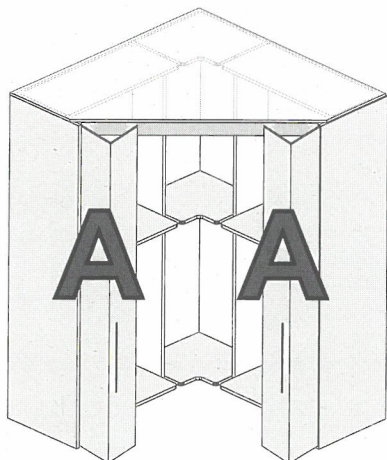

[ITA] PANNELLO CIELO SAGOMATO

[ENG] SHAPED CEILING PANEL

[DEU] GEFORMTES DECKENPANEEL



[ITA] L'installazione deve essere eseguita da personale specializzato.

[ENG] Installation must be carried out by specialized personnel

[DEU] Ausgebildetem Fachpersonal vorgenommen werden



[ITA] Un cacciavite medio a stella

[ENG] Medium Phillips screwdriver

[DEU] Mittelgroßer Kreuzschlitzschraubendreher

A



Squadretta sagomata
Shaped bracket
L-förmige Winkelplatte

B



Vite TBL 4,2x19
TBL 4,2x19 screw
Schrauben TBL 4,2x19

C



Vite TSP Ø3x25
Ø3x25 flat head
countersunk screw
Schrauben TSP Ø3x25

D



Tappo angolare
Corner cap
Eckverschluss

C



Vite TSP Ø2,5x12
Ø2,5x12 flat head
countersunk screw
Schrauben TSP Ø2,5x12

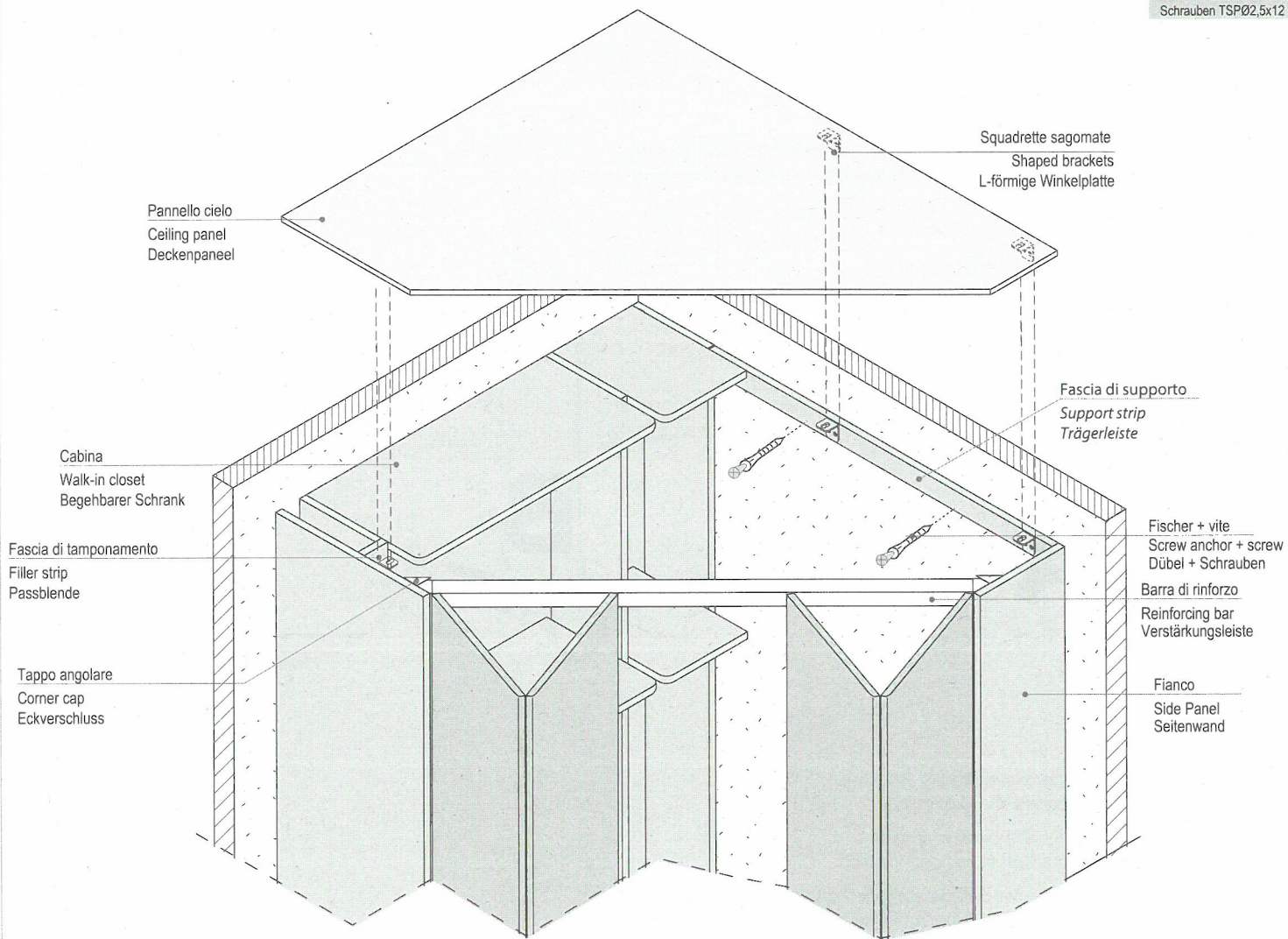

1 - Fissaggio del profilo a "L".

Unire il profilo ad "L" alla barra di rinforzo, utilizzando le apposite viti C, quindi fissare il pannello cielo al profilo con le viti E.

1 - Fastening the L-shaped profile.

Join the L-shaped profile to the reinforcing bar using the relevant screws C, then fasten the ceiling panel to the profile using screws E.

1 - Befestigung des L-Profiles.

Verbinden Sie das L-Profil mit der Verstärkungsleiste. Verwenden Sie dafür die Schrauben C. Befestigen Sie dann mit den Schrauben E das Deckenpaneel am Profil.

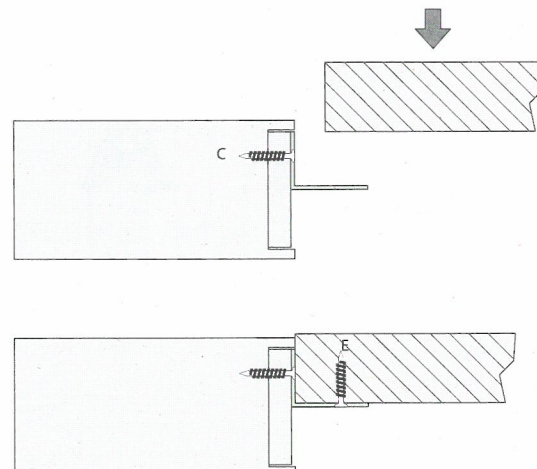
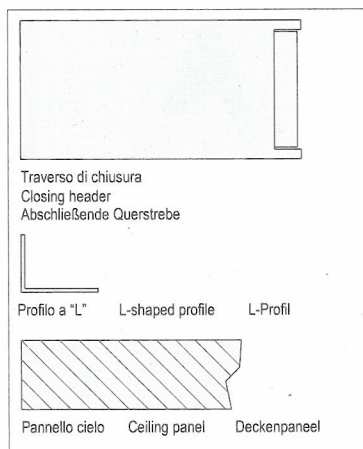

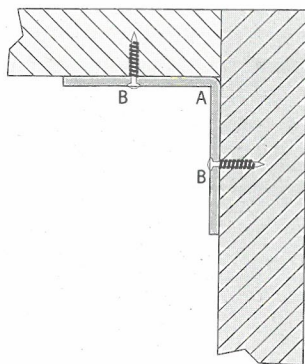
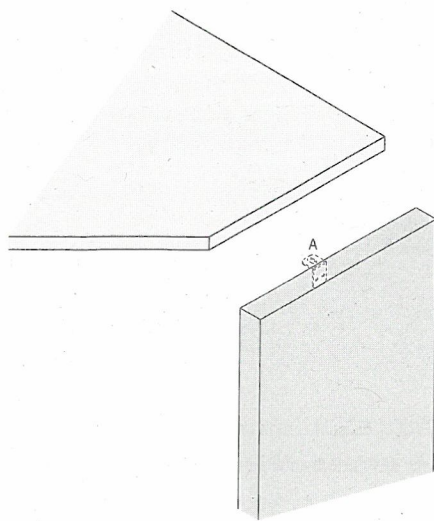

2 - Fissaggio delle squadrette sagomate.
 2 - Fastening the shaped brackets.
 2 - Befestigung der L-förmigen Winkelplatten.

3 - Fissaggio del tappo angolare.
 3 - Fastening the corner cap.
 3 - Befestigung des Eckverschlusses.

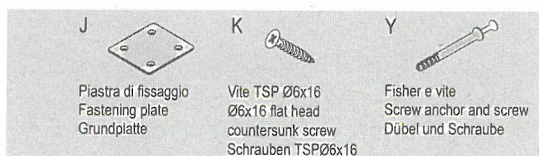
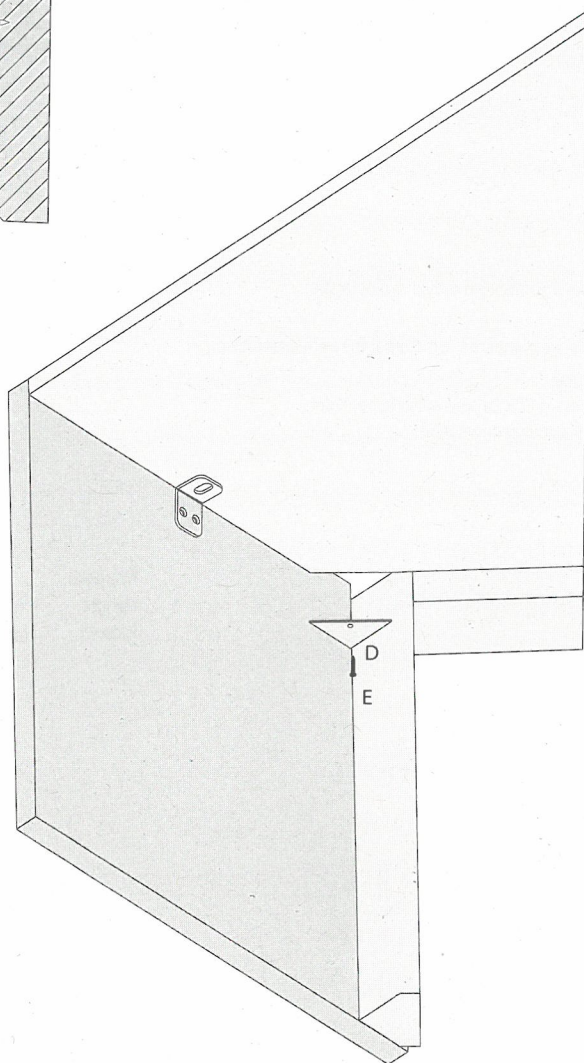

Se il cielo è in due pezzi deve prima essere fissato con delle squadrette in alluminio J date in dotazione. Bloccate con le apposite viti K.

If the ceiling panel comes in two pieces, you will need to join it together first with the aluminium plates J provided. Secure in place with the relevant screws K.

Sollte das Deckenpaneel aus zwei Teilen bestehen, müssen diese zuerst mit den beigelegten Aluminiumplatten J miteinander verbunden werden. Verwenden Sie dazu die Schrauben K.

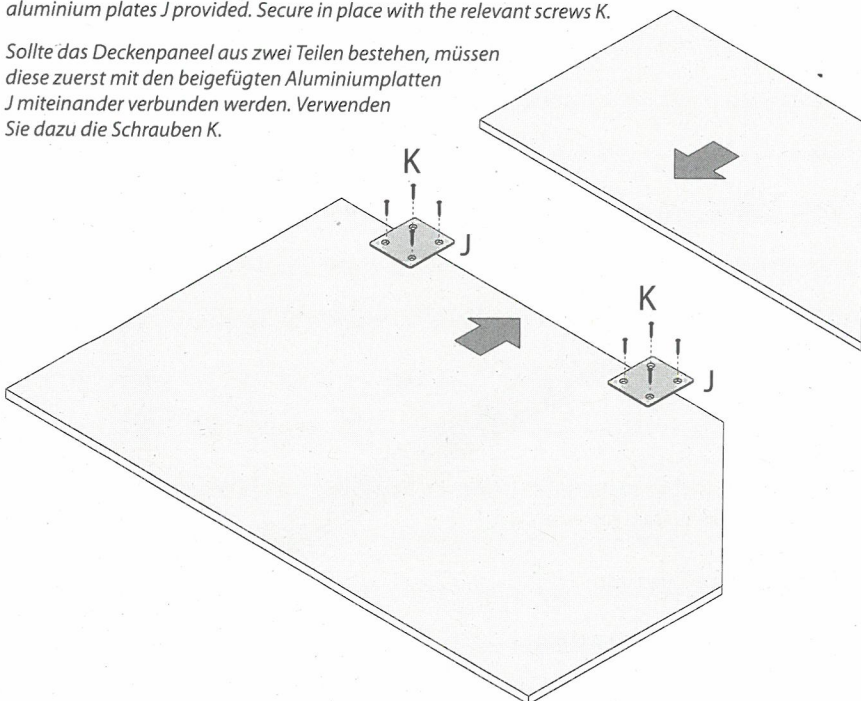

La fascia di supporto è presente solo se la cabina necessita di essere fissata a muro, in pratica non presenta altra struttura di supporto. La fascia in questione viene quindi fissata con dei fisher presenti in confezione.

The support strip is only included if the closet needs to be fastened to the wall and essentially does not have any other supporting structure. The strip in question must therefore be fastened with the screw anchors provided in the box.

Die Trägerleiste liegt nur bei, wenn der begehbare Schrank an der Wand befestigt wird. In diesem Fall weist er keine weitere tragende Struktur auf. Verwenden Sie für die Montage der Trägerleiste die beiliegenden Dübel.

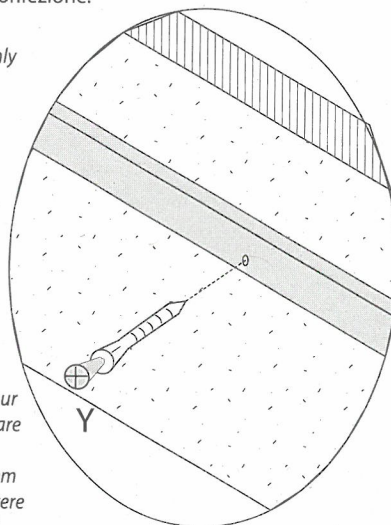

[ITA] STRUTTURA DI CHIUSURA
[ENG] CLOSING SYSTEM STRUCTURE
[DEU] TÜRSYSTEME



[ITA] L'installazione deve essere eseguita da personale specializzato.

[ENG] Installation must be carried out by specialized personnel

[DEU] Ausgebildetem Fachpersonal vorgenommen werden

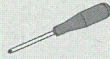

[ITA] Un cacciavite medio a stella

[ENG] Medium Phillips screwdriver
 [DEU] Mittelgroßer Kreuzschlitzschraubendreher



A
 Tirante
 Tie
 Verbindungsbolzen



B
 Grano
 Grub screw
 Gewindestift



C
 Vite TSP Ø3x25
 Ø3x25 flat head
 countersunk screw
 Schrauben TSP Ø3x25



D
 Spina
 Pin
 Stift

Nota:
 I pezzi sono numerati in ordine di montaggio.

Note:
 The parts are numbered in the order they are assembled.

Anmerkung:
 Die einzelnen Stücke sind entsprechend der Montagefolge durchnummeriert.

ATTENZIONE: Inserire i carrelli nel binario PRIMA di fissare i montanti.

PLEASE NOTE: Insert the runners in the track BEFORE fastening the uprights.

ACHTUNG: Setzen Sie die Gleitschuhe VOR der Befestigung der Pfosten in die Schiene ein.

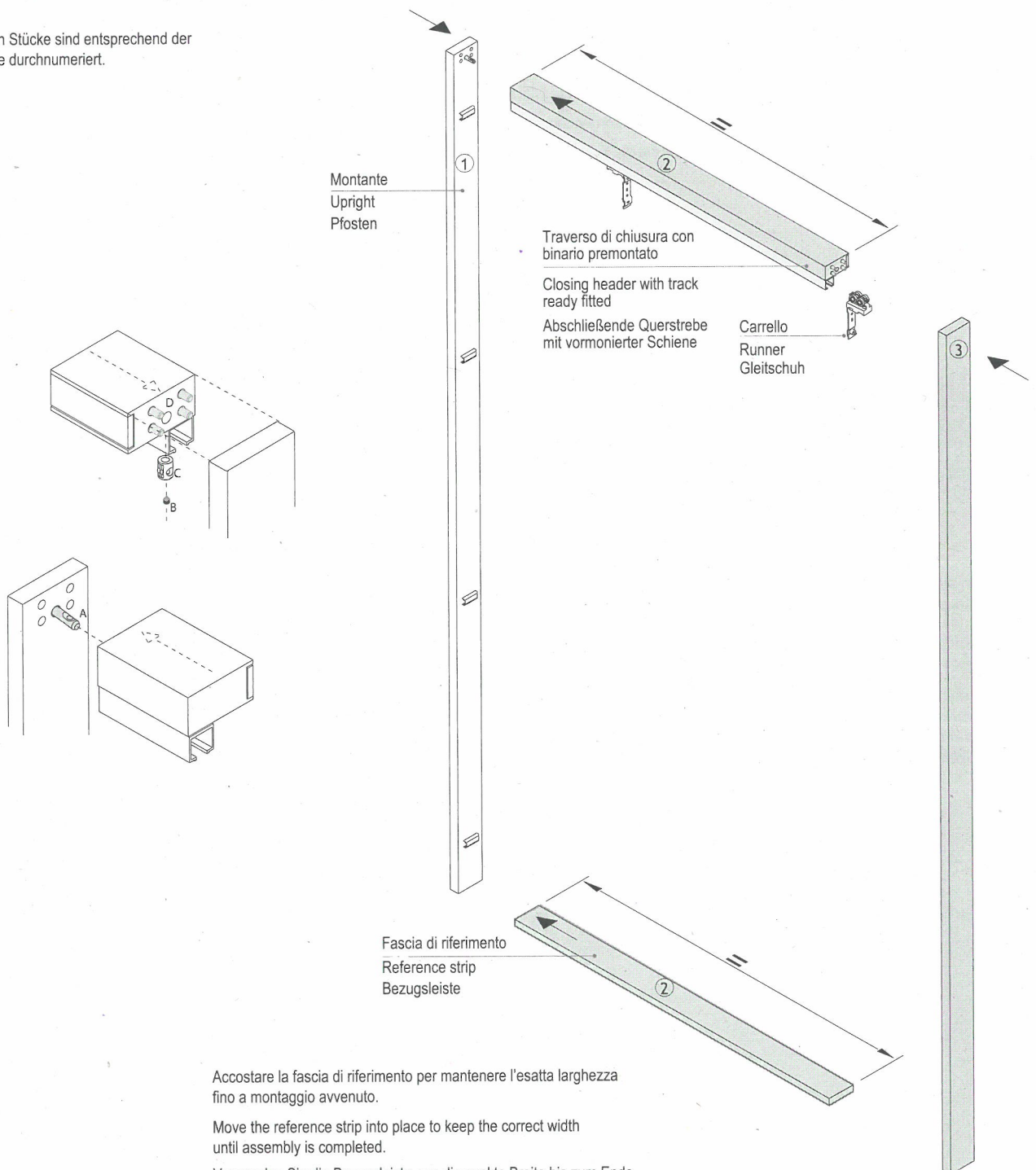

Accostare la fascia di riferimento per mantenere l'esatta larghezza fino a montaggio avvenuto.

Move the reference strip into place to keep the correct width until assembly is completed.

Verwenden Sie die Bezugsleiste, um die exakte Breite bis zum Ende der Montage beizubehalten.

[ITA] FIANCO TERMINALE CABINA TIPO 1

[ENG] WALK-IN CLOSET END SIDE PANEL TYPE 1

[DEU] ABSCHLIESSENDE SEITENWAND DES BEGEBHAREN SCHRANKES TYP 1



[ITA] L'installazione deve essere eseguita da personale specializzato.

[ENG] Installation must be carried out by specialized personnel

[DEU] Ausgebildetem Fachpersonal vorgenommen werden



[ITA] Un cacciavite medio a stella

[ENG] Medium Phillips screwdriver

[DEU] Mittelgroßer Kreuzschlitzschraubendreher

A



Montaggio
Fastener
Verbindergehäuse

B



Perno
Pin
Stift

C



Spina
Pin
Stift

D



Fisher e vite
Screw anchor and screw
Dübel und Schraube

E



Vite TMT 4,2x19
4.2x19 flat head
countersunk screw
Schraube TMT 4,2x19

PIANTA:
PLAN:
GRUNDRISS:

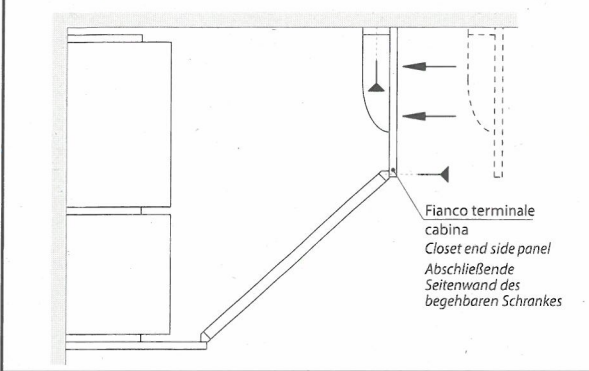

Unire la fascetta larga 70 mm al fianco terminale utilizzando gli appositi montaggi e spine in dotazione. (I fori per i montaggi devono essere rivolti verso il muro).

Unire le piastre metalliche sagomate al fianco mediante le apposite viti TMT 4,2x19.

Join the 70mm-wide strip to the end side panel using the relevant fasteners, pins and dowels provided.

(The holes for the fasteners must face the wall).
Fasten the shaped metal plates to the side panel using the relevant 4,2x19 screws.

Verbinden Sie die 70 mm breiten Blenden mit der abschließenden Seitenwand.

Verwenden Sie dafür Verbindergehäuse und einfache Stifte.

(Die Bohrungen für die Montage müssen in Richtung Wand zeigen).
Verbinden Sie die abgewinkelte Metallgrundplatten mit der Seitenwand.
Verwenden Sie dafür die Schrauben TMT 4,2x19

n°4 perni per montaggio fascia
4 pins for fitting strip
4 Stifte für die Montage der Blende

Fascetta L.70 mm
70mm-wide strip
Blende B.70 mm

n°4 spine legno Ø8 x 30
4 wooden dowels Ø8 x 30
4 einfache Holzstifte Ø8 x 30

Montaggi dal retro
Fasteners fitted from rear
Von hinten montieren

Piastra metallica sagomata

Shaped metal plate
Abgewinkelte Metallgrundplatte

Fianco terminale
End side panel
Abschließende Seitenwand

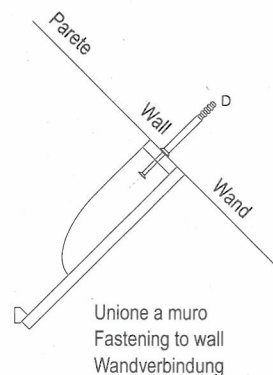
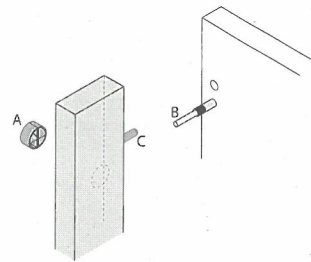

[ITA] MONTANTI PENTAGONALI

[ENG] PENTAGONAL UPRIGHTS

[DEU] FÜNFECKIGER PFOSTEN



[ITA] L'installazione deve essere eseguita da personale specializzato.

[ENG] Installation must be carried out by specialized personnel

[DEU] Ausgebildetem Fachpersonal vorgenommen werden



[ITA] Un cacciavite medio a stella

[ENG] Medium Phillips screwdriver

[DEU] Mittelgroßer Kreuzschlitzschraubendreher

A



Tirante
Tie
Verbindungsbolzen

B



Grano
Grub screw
Gewindestift

C



Vite TSP Ø3x25
Ø3x25 flat head
countersunk screw
Schrauben TSP Ø3x25

D



Spina
Pin
Stift

D



Fisher e vite
Screw anchor and screw
Dübel und Schraube

ATTENZIONE: Inserire i carrelli nel binario PRIMA di fissare i montanti.

PLEASE NOTE: Insert the runners in the track BEFORE fastening the uprights.

ACHTUNG: Setzen Sie die Gleitschuhe VOR der Befestigung der Pfosten in die Schiene ein.

- Montante pentagonale/triangolare.
Unione al traverso di chiusura.

- Pentagonal/triangular upright.
Connection to closing header.

- Fünf-/dreieckiger Pfosten.
Mit der abschließenden Querstrebe verbinden.

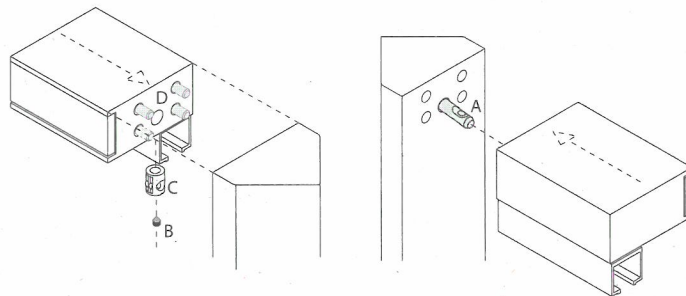

- Montante pentagonale.
Unione al fianco.

- Pentagonal upright.
Connection to side panel.

- Fünfeckiger Pfosten.
Mit der Seitenwand verbinden.

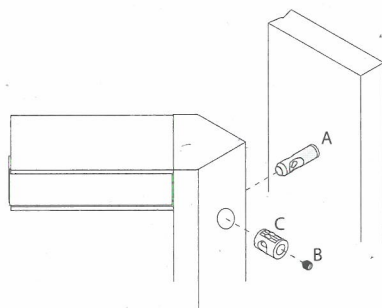

Allineare sempre il foro del tirante al foro presente sul montante.
Make sure the hole in the tie is always lined up with the hole drilled in the base.
Die Öffnung des Spannbolzens muss genau in einer Linie mit der Bohrung der Bodenplatte liegen.

Montante
Upright
Pfosten

Traverso di chiusura
con binario premontato
Closing header with
track ready fitted
Abschließende Querstrebe
mit vormontierter Schiene

Carrello
Runner
Gleitschuh

Accostare la fascia di riferimento per mantenere l'esatta larghezza fino a montaggio avvenuto.

Move the reference strip into place to keep the correct width until assembly is completed

Verwenden Sie die Bezugsleiste, um die exakte Breite bis zum Ende der Montage beizubehalten.

Nota:
I pezzi sono numerati in ordine di montaggio.

Note:
The parts are numbered in the order they are assembled.

Anmerkung:
Die einzelnen Stücke sind entsprechend der Montagefolge durchnummeriert.

Fascia di riferimento
Reference strip
Bezugsleiste

[ITA] TUBO APPENDIABITI STANDARD / PLUS

[ENG] STANDARD / PLUS HANGING RAIL

[DEU] KLEIDERSTANDEN STANDARD / PLUS



[ITA] L'installazione deve essere eseguita da personale specializzato.

[ENG] Installation must be carried out by specialized personnel

[DEU] Ausgebildetem Fachpersonal vorgenommen werden



[ITA] Un cacciavite medio a stella

[ENG] Medium Phillips screwdriver

[DEU] Mittelgroßer Kreuzschlitzschraubendreher

A



Vite TBL M8 x 35
M8 x 35 truss head screw
Schrauben TBL M8 x 35

- 1 - Rendere passanti i fori impronta sul cappello e/o sul ripiano.
- 1 - Drill the pilot holes in the top cover and/or in the shelf all the way through.
- 1 - Durchbohren Sie an den angebohrten Stellen die Deckplatte und/oder den Einlegeboden.

1

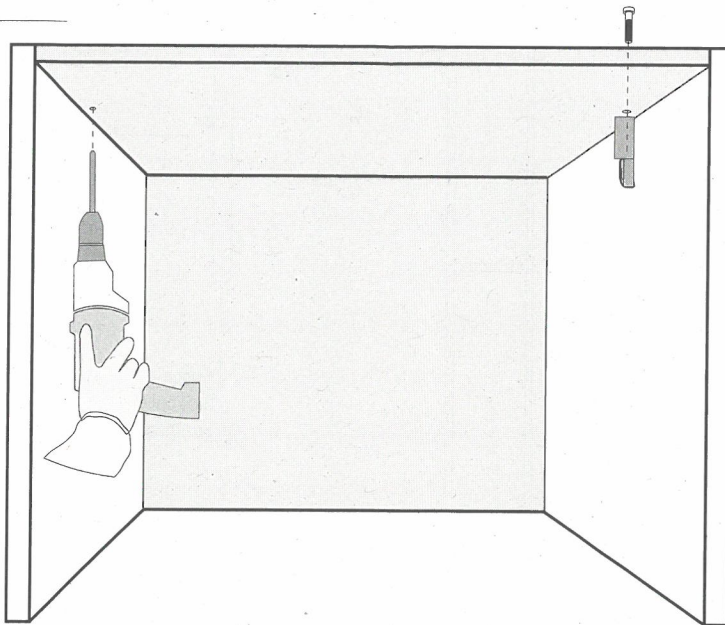

N.B.: Si consiglia di fissare il tubo e reggitubo prima di montare l'armadio.

NB: It is best to fasten the rail and rail support before assembling the wardrobe.

ANM.: Es empfiehlt sich, die Kleiderstange und ihre Halterungen vor dem Schrankaufbau zu befestigen.

- 2 - Per tubo STANDARD / PLUS: Avvitare un reggitubo al cappello/ripiano. Inserire il tubo e bloccarlo avvitando l'altro reggitubo.
- 2 - For STANDARD / PLUS rail: Screw a rail support into the top cover/shelf. Insert the rail and secure by screwing in the other rail support.
- 2 - Für Kleiderstange STANDARD / PLUS: Verschrauben Sie eine Kleiderstangenhalterung an der Deckplatte/am Einlegeboden. Setzen Sie die Kleiderstange ein und arretieren Sie diese durch Verschrauben der zweiten Kleiderstangenhalterung.

2

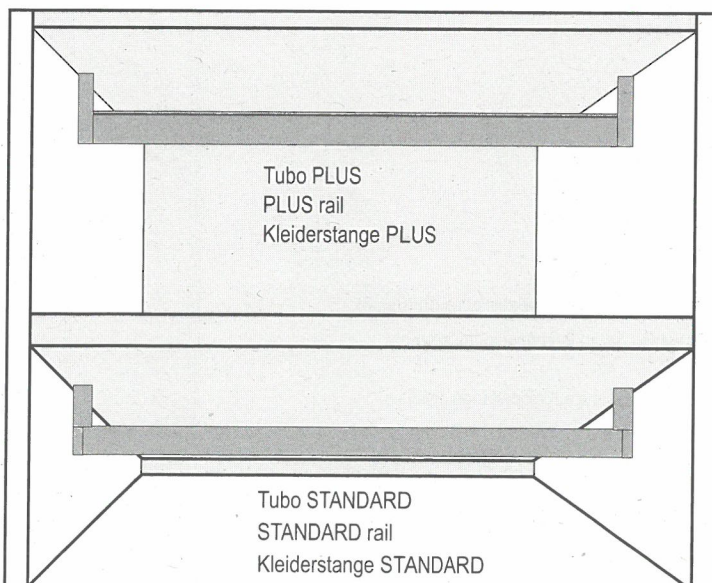

[ITA] PORTA ABITI LATERALE ESTERNO

[ENG] EXTERNAL SIDE HANGING RAIL

[DEU] SEITLICHE KLEIDERSTANGE FÜR DIE AUSSENSEITE DER SCHRANKSEITENWAND



[ITA] L'installazione deve essere eseguita da personale specializzato.

[ENG] Installation must be carried out by specialized personnel

[DEU] Ausgebildetem Fachpersonal vorgenommen werden



[ITA] Un cacciavite medio a stella

[ENG] Medium Phillips screwdriver

[DEU] Mittelgroßer Kreuzschlitzschraubendreher



Vite TBL 6Mx40
M6x40 truss head screw
Schrauben TBL 6Mx40



Vite TSP M4x20
M4x20 flat head countersunk screw
Schrauben TSP M4x20

1 - Rendere passanti i 3 fori Ø 8 presenti nel lato interno del fianco.

N.B.: Il porta abiti laterale viene fissato al fianco con vite 6M.

1 - Drill the three 8mmØ holes in the inside of the side panel all the way through.

NB: The side hanging rail must be fastened to the side panel using the M6 screw.

1 - Durchbohren Sie die 3 an der Innenseite der Seitenwand vorbereiteten Löcher mit Ø 8.

ANM.: Die seitliche, außenliegende Kleiderstange wird an der Seitenwand mit den Schrauben 6M fixiert.

2 - Fissare parzialmente il porta abiti laterale al fianco (Fig. 1).

2 - Fasten the side hanging rail to the side panel without screwing it in all the way (Fig. 1).

2 - Schrauben Sie die seitliche, außenliegende Kleiderstange an die Seitenwand, ohne die Schrauben festzuziehen (Abb. 1).

Fig. 1
Fig. 1
Abb. 1

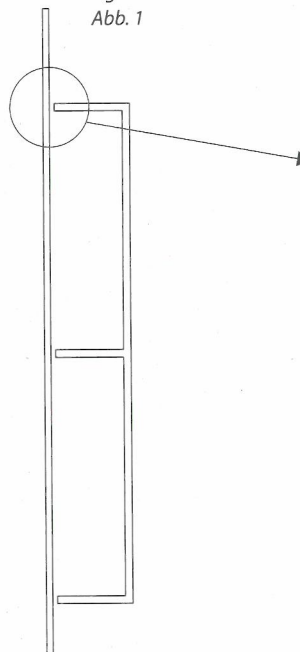

PARTICOLARE
DETAIL
DETAILANSICHT

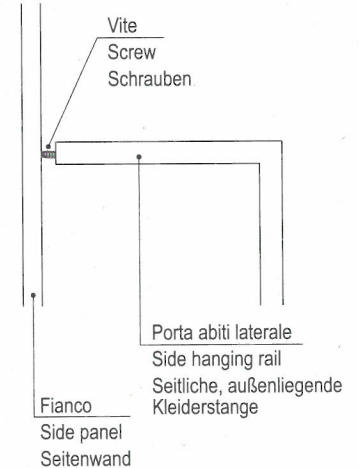
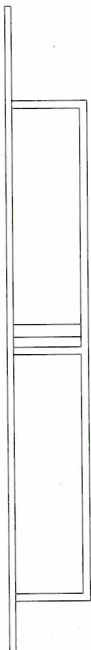

Fig. 2
Fig. 2
Abb. 2



3 - Fissare la vaschetta al porta abiti con le viti M4 in dotazione (Fig. 2).

3 - Fasten the tray to the hanging rail using the M4 screws provided (Fig. 2).

3 - Befestigen Sie die Ablage der Kleiderstange mit den beiliegenden Schrauben M4 (Abb. 2).

Fig. 3
Fig. 3
Abb. 3

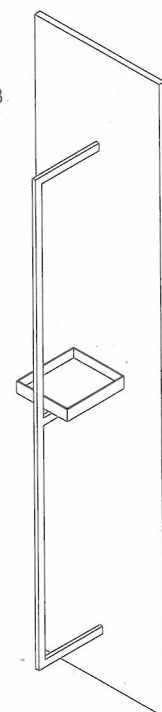

4 - Avvitare le viti 6M per fissare definitivamente il porta abiti al fianco (Fig. 3).

4 - Screw the M6 screws in all the way to fasten the hanging rail securely to the side panel (Fig. 3).

4 - Ziehen Sie nun die Schrauben 6M fest, um die Kleiderstange definitiv an der Seitenwand zu befestigen (Abb. 3).

[ITA] PORTA ABITI LATERALE ESTERNO

[ENG] EXTERNAL SIDE HANGING RAIL

[DEU] SEITLICHE KLEIDERSTANGE FÜR DIE AUSSENSEITE DER SCHRANKSEITENWAND



[ITA] L'installazione deve essere eseguita da personale specializzato.

[ENG] Installation must be carried out by specialized personnel

[DEU] Ausgebildetem Fachpersonal vorgenommen werden



[ITA] Un cacciavite medio a stella

[ENG] Medium Phillips screwdriver

[DEU] Mittelgroßer Kreuzschlitzschraubendreher



Vite TC 4x25
4x25 truss head screw
Schrauben TC 4x25

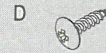

Vite TB 4,2X15
TC 4,2x15 screw
Schrauben TC 4,2x15



Vite TBL M4x10
TBL M4x10 screw
Schrauben M4x10

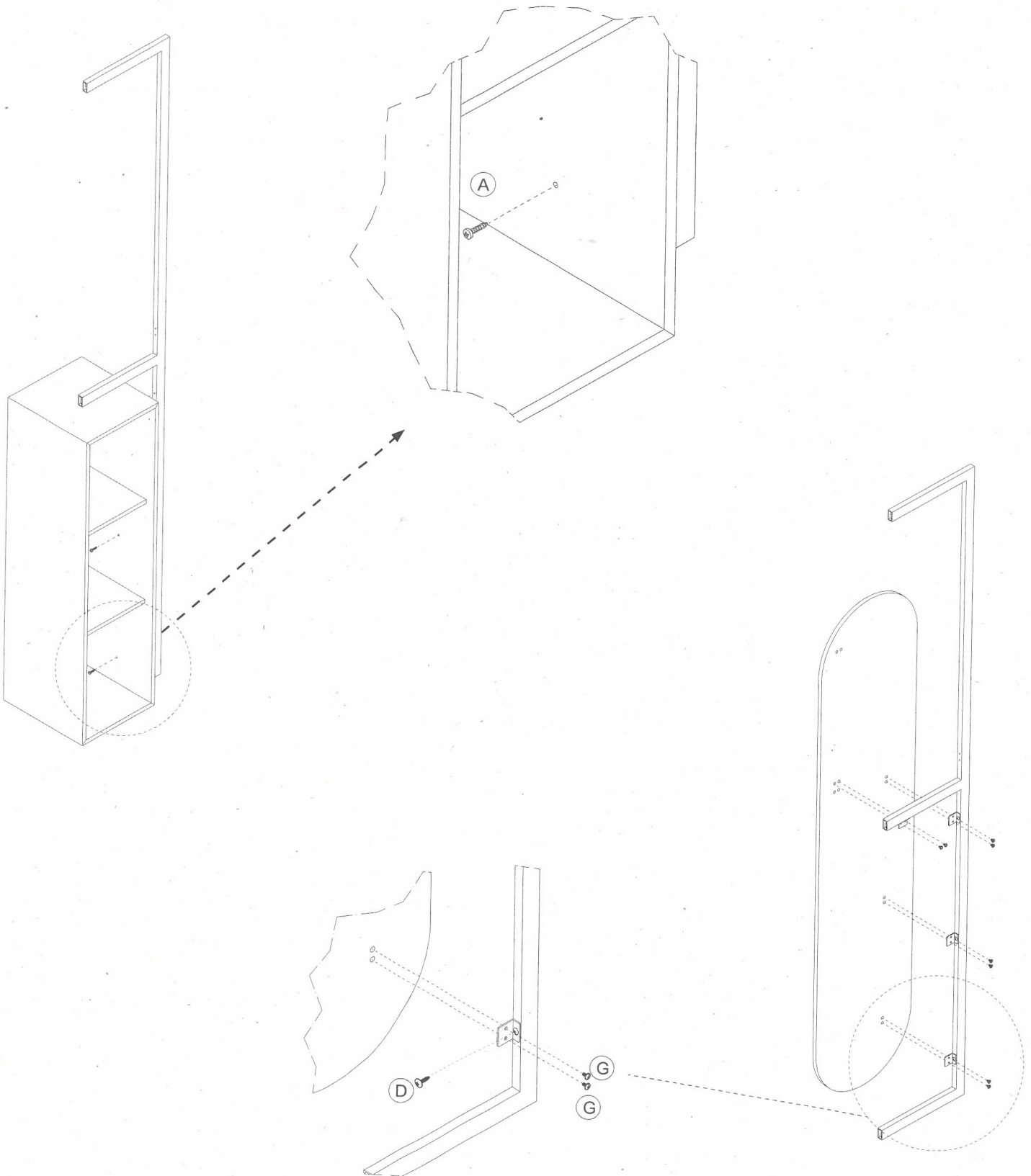

[ITA] CASSETTI ESTERNI ARMADIO
[ENG] EXTERNAL WARDROBE DRAWERS
[DEU] SCHUBLADEN FÜR SCHRÄNKE



[ITA] L'installazione deve essere eseguita da personale specializzato.
 [ENG] Installation must be carried out by specialized personnel
 [DEU] Ausgebildetem Fachpersonal vorgenommen werden



[ITA] Un cacciavite medio a stella
 [ENG] Medium Phillips screwdriver
 [DEU] Mittelgroßer Kreuzschlitzschraubendreher



Vite TSP Ø3,5x16
 Ø3,5x16 flat head countersunk screw
 Schraube TSPØ3,5x16

1 - Fissare il cassetto al fianco dell'armadio come in Fig. 1 utilizzando i fori indicati.

1 - Fasten the drawer to the wardrobe's side panel as shown in Fig. 1 using the holes marked on the drawing.

1 - Befestigen Sie die Schublade an der Schrankinnenseite wie in Abb. 1 dargestellt. Nutzen Sie dafür die vorbereiteten Bohrungen.

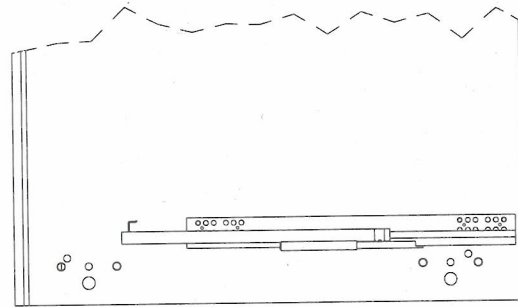

Fori per fissaggio
 Holes for fastening
 Bohrungen für die Schubladenmontage

Fig. 1
 Fig. 1
 Abb. 1

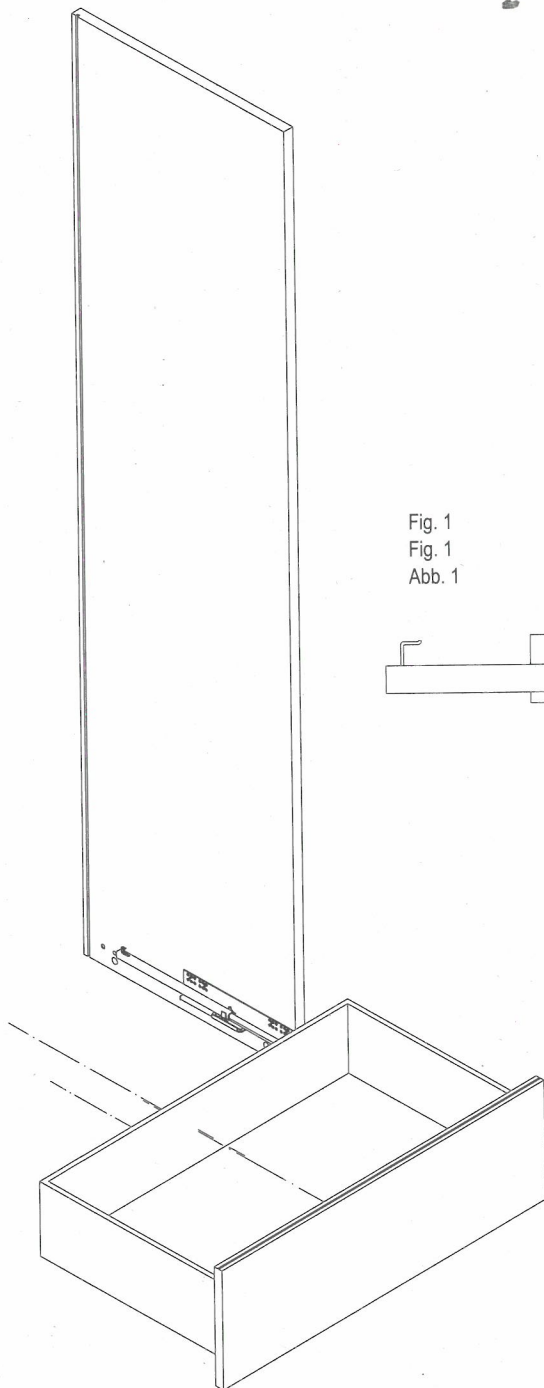
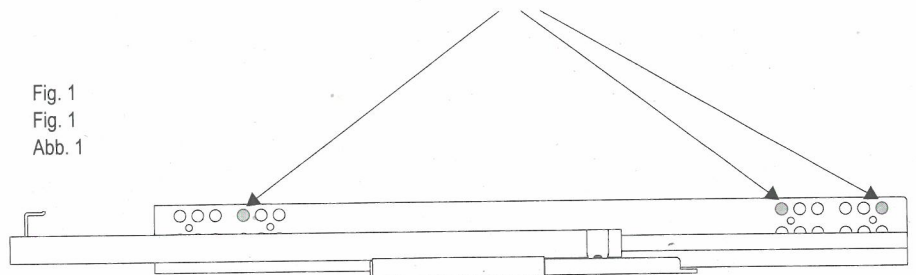

[ITA] RIPIANO LUCE LED

[ENG] LED LIGHT SHELF

[DEU] EINLEGEBODEN MIT LED-BELEUCHTUNG



[ITA] L'installazione deve essere eseguita da personale specializzato.

[ENG] Installation must be carried out by specialized personnel

[DEU] Ausgebildetem Fachpersonal vorgenommen werden

Fig. 1

Fig. 1

Abb. 1

- 1 - Legare nel punto A, con un pezzetto di scotch il cavo della luce LED allo spago già presente nel ripiano.
- 1 - Sellotape the LED light cable to the string sticking out of the shelf at point A.
- 1 - Verbinden Sie das Kabel der LED-Leuchte am Punkt A mit einem Klebestreifen mit der bereits im Einlegeboden befindlichen Schnur.

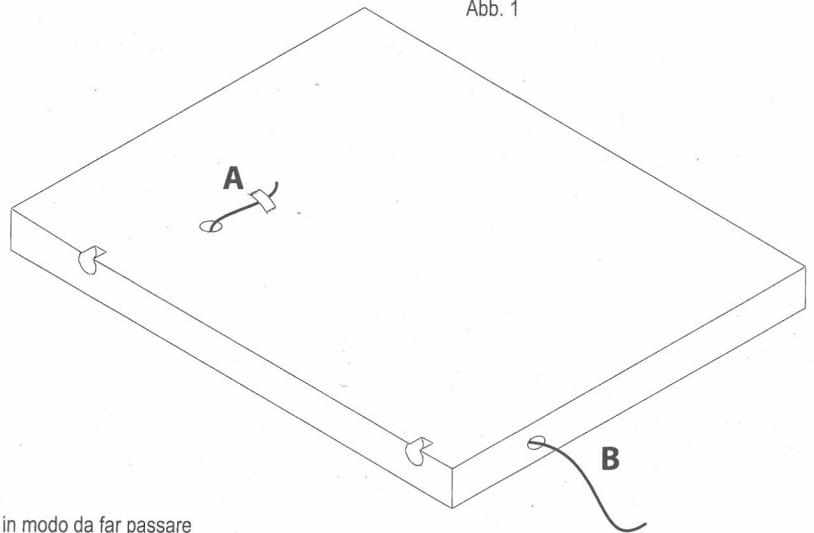

2 - Far uscire dal punto B lo spago in modo da far passare il cavo della luce LED nel ripiano.

2 - Pull the string out at point B so that the LED light cable is made to run through the shelf.

2 - Ziehen Sie am Punkt B an der Schnur und führen Sie dadurch das Kabel der LED-Leuchte durch den Einlegeboden.

3 - Pulire bene la superficie del ripiano e fissare la luce LED con la pellicola adesiva già applicata. Collegare il cavo all'alimentatore.

3 - Clean the surface of the shelf thoroughly and fasten the LED light with the adhesive backing applied. Connect the cable to the power supply.

3 - Reinigen Sie sorgfältig die Oberfläche des Einlegebodens und befestigen Sie die LED-Leuchte unter Verwendung des bereits werkseitig vorbereiteten Klebestreifens. Stellen Sie nun den Anschluss an die Stromversorgung her.

Fig. 2

Fig. 2

Abb. 2

Foro su schiena da eseguire in fase di montaggio

Hole in back panel to be drilled during assembly

Loch in der Rückwand, Bohrung bitte während der Montage durchführen

Lato frontale del ripiano

Front edge of shelf

Vorderseite des Einlegebodens

Lato retro con luce LED

Underside with LED light

Nach hinten strahlende LED-Leuchte

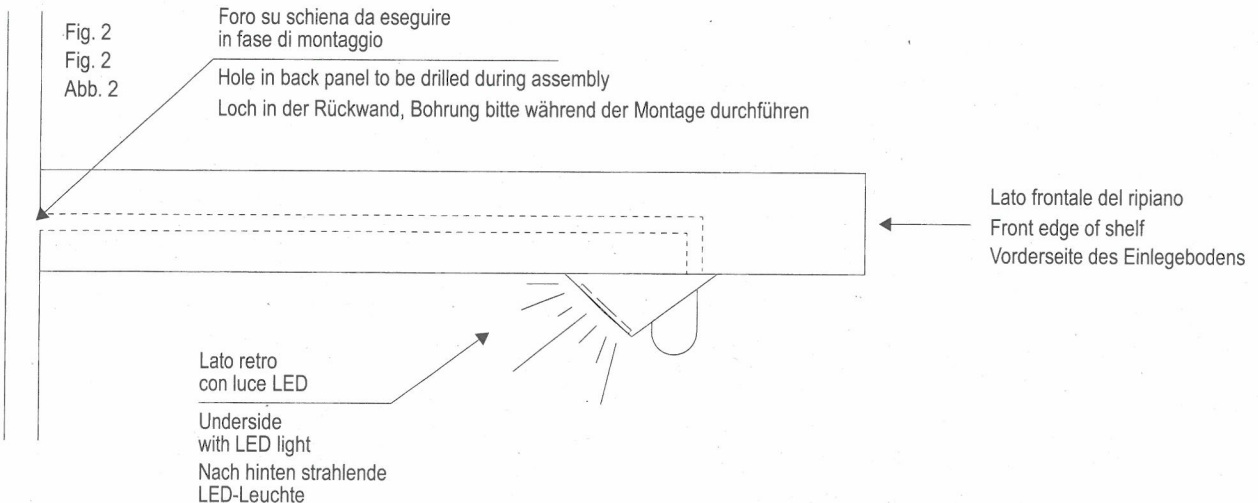

[ITA] PORTA TV
[ENG] TV UNIT
[DEU] TV TRÄGER-SET



[ITA] L'installazione deve essere eseguita da personale specializzato.
 [ENG] Installation must be carried out by specialized personnel
 [DEU] Ausgebildetem Fachpersonal vorgenommen werden

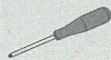

[ITA] Un cacciavite medio a stella
 [ENG] Medium Phillips screwdriver
 [DEU] Mittelgroßer Kreuzschlitzschraubendreher

A



Vite TCEI 6Mx16
 M6x16 socket head cap screw
 Schrauben TCEI 6Mx16

B



Vite TBL M8x50
 TBL M8x50 screw
 Schrauben TBL M8x50

- 1 - Applicare il pannello al telaio e fissarlo con le viti 6M in dotazione.
- 1 - Fit the panel on the frame and fasten it using the M6 screws provided.
- 1 - Montieren Sie das Panel am Rahmen und befestigen Sie es mit den beiliegenden Schrauben 6M.

Fig. 1
 Fig. 1
 Abb. 1

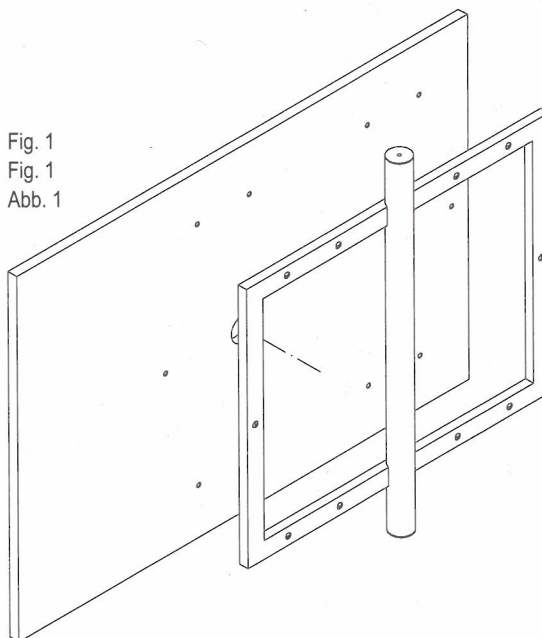

Vista da sotto -
 Seen from underneath
 Ansicht von unten

Fig. 2
 Fig. 2
 Abb. 2

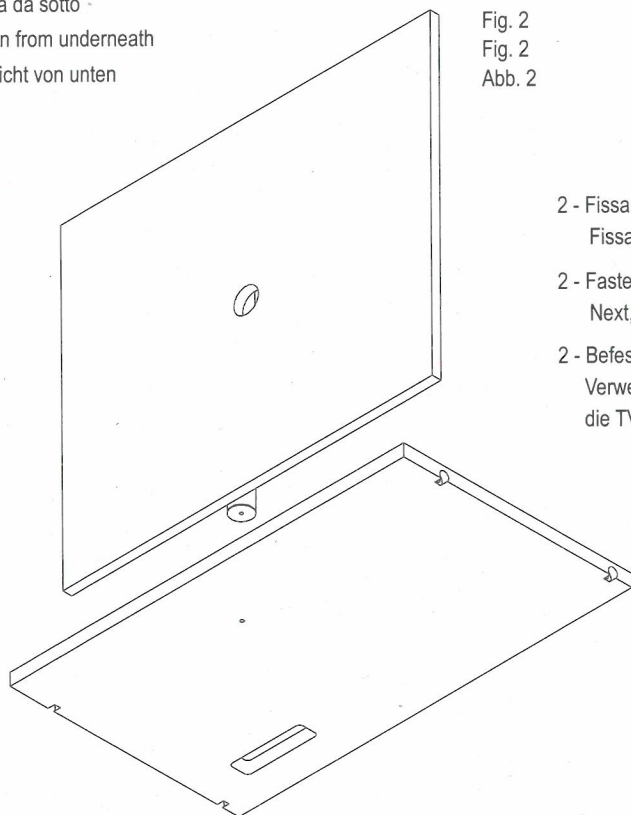

- 2 - Fissare da sotto il ripiano il palo porta TV con viti M8 in dotazione.
 Fissare poi dall'alto il palo porta TV al ripiano e bloccarlo completamente.
- 2 - Fasten the TV mounting post from underneath the shelf using the M8 screws provided.
 Next, fasten the TV mounting post to the shelf from above and secure it permanently.
- 2 - Befestigen Sie den Einlegeboden von unten an der TV-Trägersäule.
 Verwenden Sie dazu die beiliegenden Schrauben M8. Arretieren Sie nun von oben die TV-Trägersäule am Einlegeboden und ziehen Sie die Schrauben endgültig fest.

[ITA] CASSETTIERA INTERNA ARMADIO
 [ENG] WARDROBE INTERIOR DRAWER UNIT
 [DEU] INNERES SCHUBLADENELEMENT IM SCHRANK



[ITA] L'installazione deve essere eseguita da personale specializzato.

[ENG] Installation must be carried out by specialized personnel

[DEU] Ausgebildetem Fachpersonal vorgenommen werden

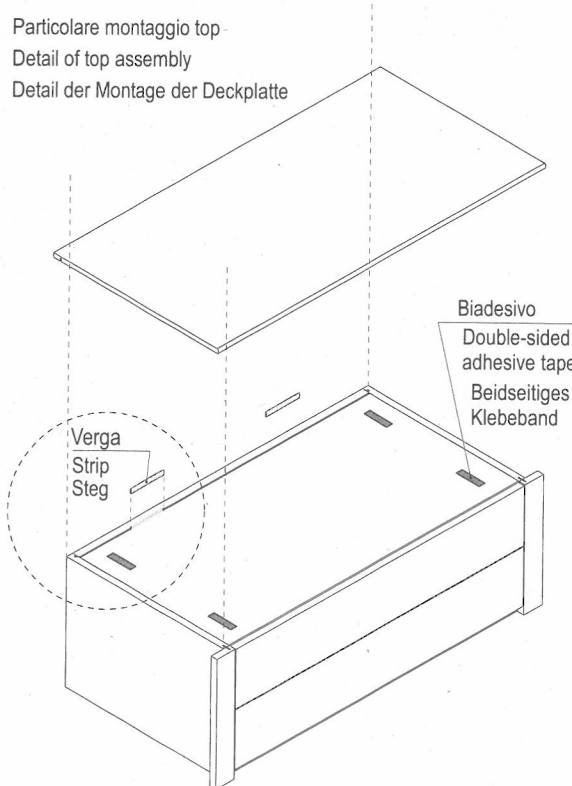
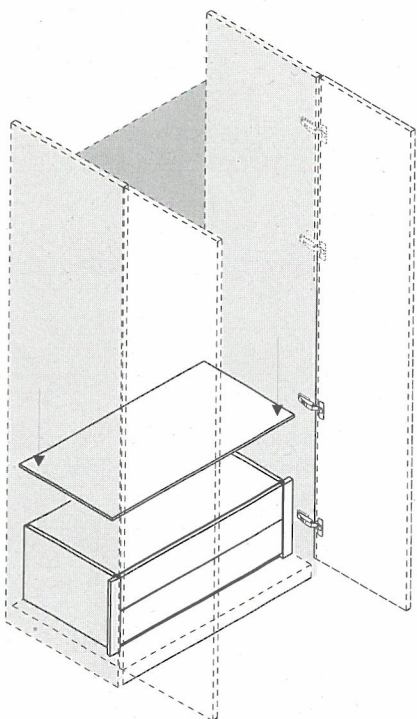
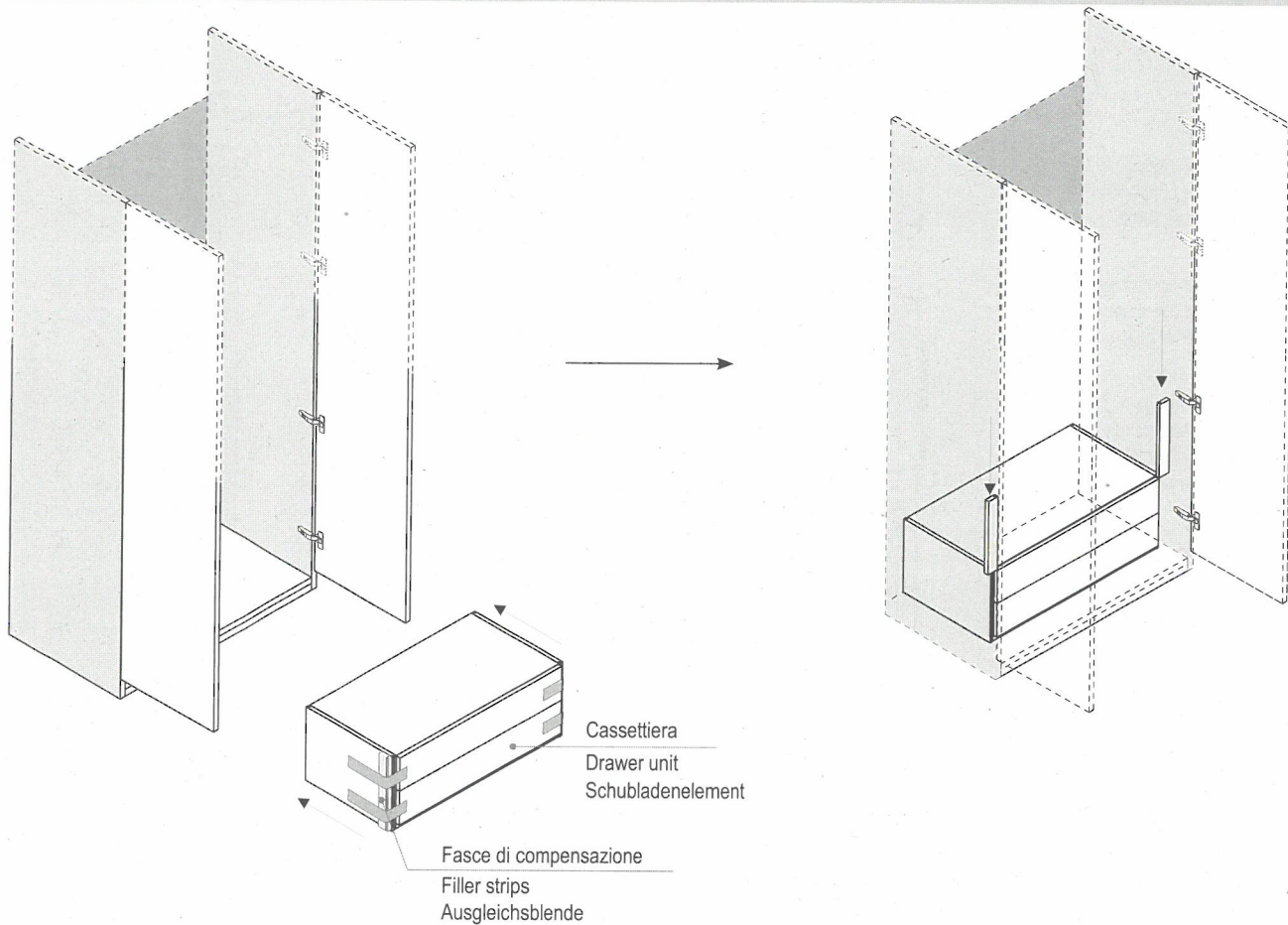

[ITA] MONTANTE COMPENSATORE

[ENG] FILLER UPRIGHT

[DEU] AUSGLEICHSPFOSTEN



[ITA] L'installazione deve essere eseguita da personale specializzato.

[ENG] Installation must be carried out by specialized personnel

[DEU] Ausgebildetem Fachpersonal vorgenommen werden



[ITA] Un cacciavite medio a stella

[ENG] Medium Phillips screwdriver

[DEU] Mittelgroßer Kreuzschlitzschraubendreher

Posizionare la parte A del montante compensatore a ridosso del muro e controllare che sia a bolla nei due sensi, come da disegno.

Sit part A of the filler upright up against the wall and use a spirit level to check it is level both ways, as illustrated.

Stellen Sie den linken Teil A des Ausgleichspfostens an die Wand. Richten Sie ihn mit einer Wasserwaage wie in der Abbildung dargestellt aus.

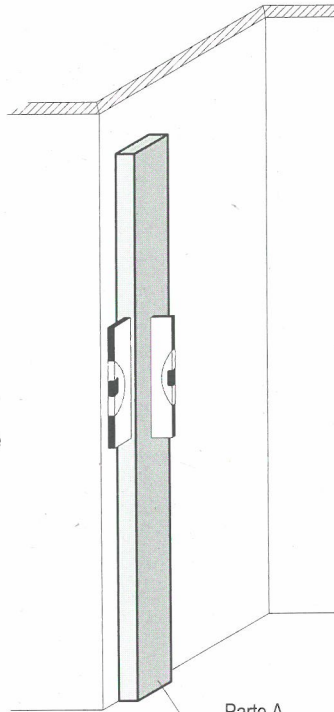

Parte A
Part A
Teil A

Fissare a muro con le viti con tassello lungo.

Fasten to the wall using the screws with long anchors.

Befestigen Sie ihn mit Schrauben und langen Dübeln an der Wand.

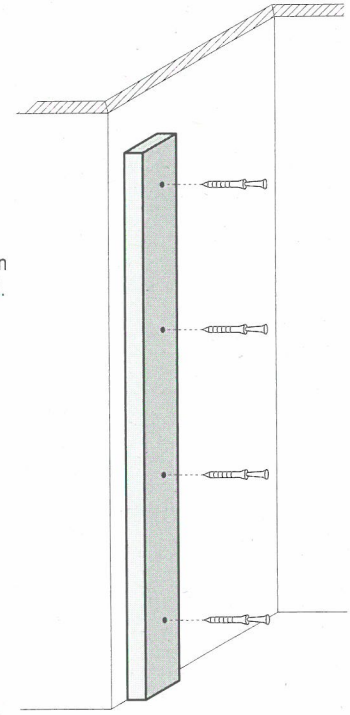

Accostare la parte B alla parte A e, una volta trovata l'esatta posizione, fissarla con le squadrette a "L".

Set part B up against part A and, once you've got it into the right position, fasten it using the L-shaped brackets.

Stellen Sie den rechten Teil B an den Teil A. Finden Sie seine exakte Position und arretieren Sie beide Teile mit den L-förmigen Winkeln.

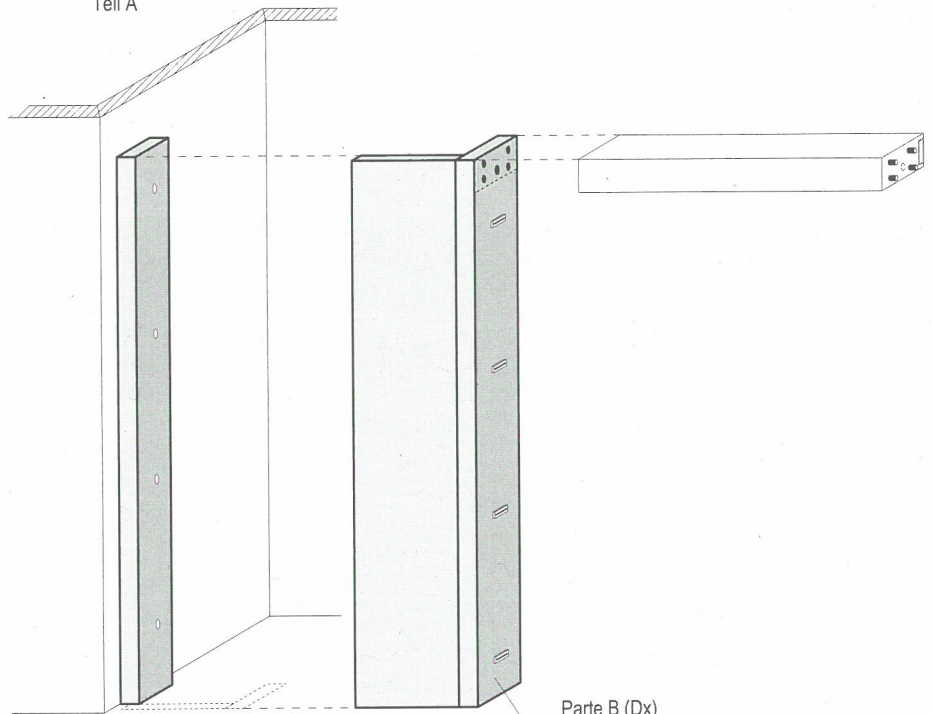

Parte B (Dx)
Part B (Rh)
Teil B (Rechts)

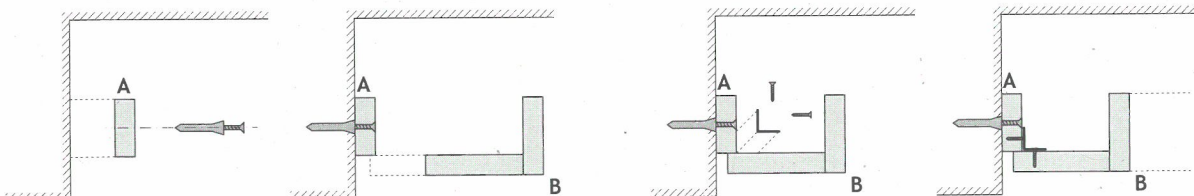

[ITA] FASCE DI AGGIUSTAMENTO

[ENG] ADJUSTMENT STRIPS

[DEU] PASSBLENDEN



[ITA] L'installazione deve essere eseguita da personale specializzato.

[ENG] Installation must be carried out by specialized personnel

[DEU] Ausgebildetem Fachpersonal vorgenommen werden



[ITA] Un cacciavite medio a stella

[ENG] Medium Phillips screwdriver

[DEU] Mittelgroßer Kreuzschlitzschraubendreher



Vite TPS Ø3,9x38
Ø3,9x38 flat head
countersunk screw
Schrauben TPS Ø3,9x38

ARMADIO BATTENTE/PIEGHEVOLE HINGED/FOLDING DOOR WARDROBE SCHRÄNKE MIT FLÜGEL-/FALTTÜREN

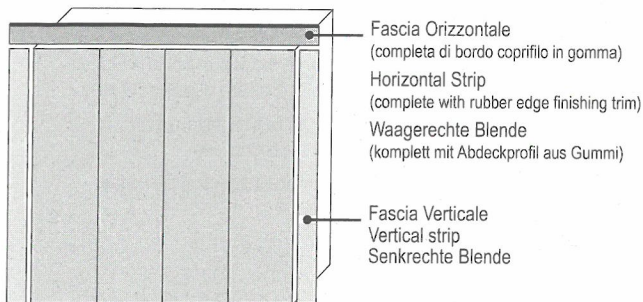

ARMADIO SCORREVOLE SLIDING DOOR WARDROBE SCHIEBETÜRENSCHRANK

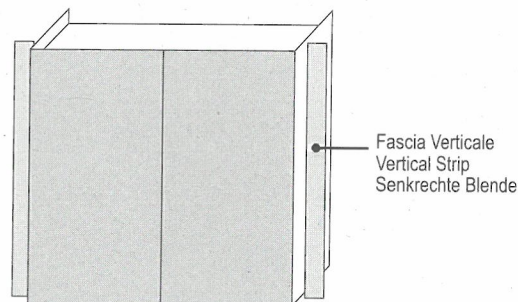

Fissaggio fascia VERTICALE:

Fastening the VERTICAL strip:

Befestigung der SENKRECHTEN Blende:

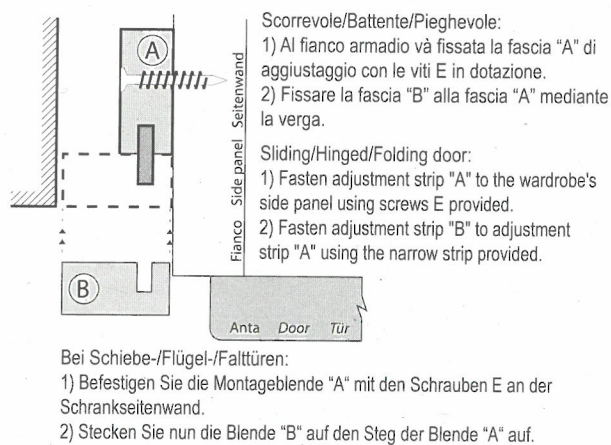

Fissaggio fascia ORIZZONTALE:

Fastening the HORIZONTAL strip:

Befestigung der WAAGERECHTEN Blende:

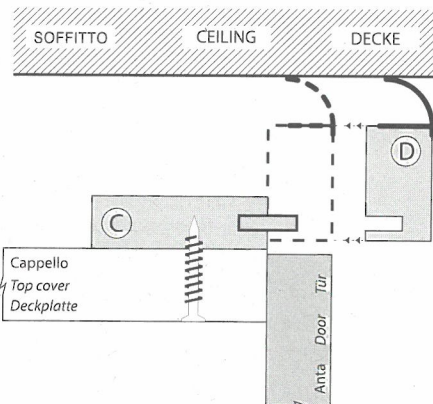

Battente/Pieghevole:

- 1) Al cappello armadio v'è fissata la fascia "C" di aggiustaggio con le viti E in dotazione, allineandola sempre con la parte frontale.
- 2) Fissare la fascia "D" alla fascia "C" mediante la verga.

Hinged/Folding door:

- 1) Fasten adjustment strip "C" to the wardrobe's top cover using screws E provided, again lining it up with the front.
- 2) Fasten adjustment strip "D" using the narrow strip provided.

Bei Flügel-/Falttören:

- 1) Befestigen Sie die Montageblende "C" mit den Schrauben E an der Deckplatte des Schrankes. Achten Sie auf die Bündigkeit nach vorn.
- 2) Stecken Sie nun die Blende "D" auf den Steg der Blende "C" auf.

[ITA] TERMINALE LATERALE
[ENG] SIDE END UNIT
[DEU] SEITLICHES SCHLUSSELEMENT



[ITA] L'installazione deve essere eseguita da personale specializzato.
 [ENG] Installation must be carried out by specialized personnel
 [DEU] Ausgebildetem Fachpersonal vorgenommen werden



[ITA] Un cacciavite medio a stella
 [ENG] Medium Phillips screwdriver
 [DEU] Mittelgroßer Kreuzschlitzschraubendreher

A



Reggipiano
 Shelf support
 Einlegebodenträger

Frontale sp.22 L.345 (H. come anta).
 A montaggio completato rimane sollevato da terra allineato ai frontali vicini
 22 mm thick - 345 mm wide fix front panel (as high as doors)
 After the installation it will be off the ground, at the same height as the door nearby
 22 mm stark - 345 mm breit fix Front (als hoch als die Türen)
 Nach der Installation wird die Front vom Boden entfernt sein, auf der gleichen Höhe wie die Tür daneben

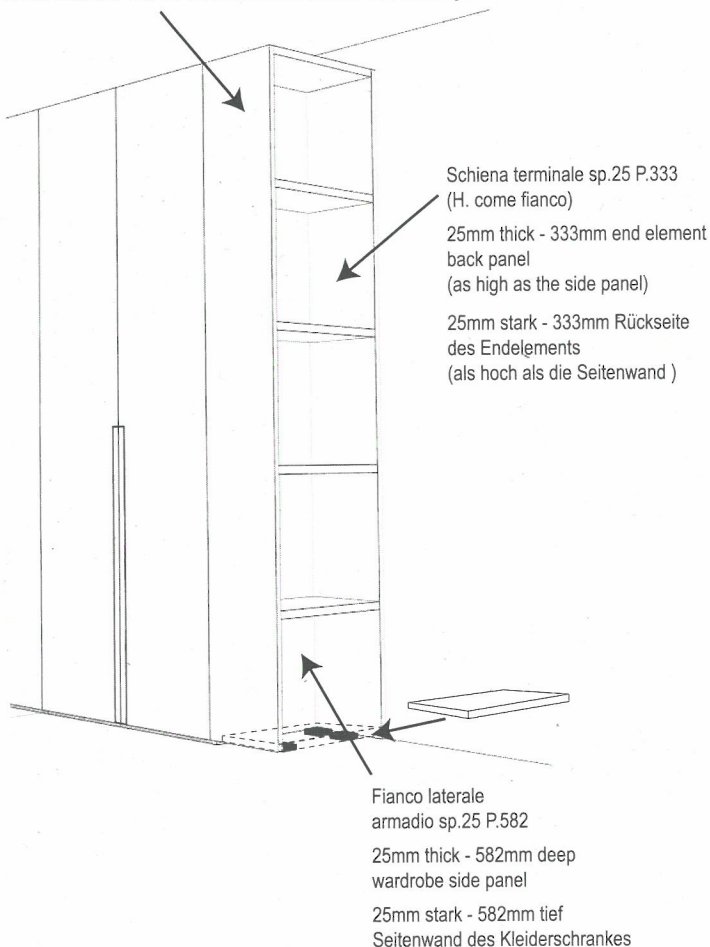

- 1- Applicare i reggipiani A alla schiena terminale e al fianco laterale in corrispondenza dei fori appositamente predisposti.
- 1 - Insert the shelf supports (A) into the drillings made in the back panel and in the side panel
- 1 - die Halterungen der Fächer (A) in die Bohrungen in der Rückwand und in der Seitenwand einsetzen
- 2 - Posizionare la schiena terminale perpendicolare al fianco laterale e fissare i ripiani del terminale - con esclusione di quello in basso -
- 2 - Place the back panel perpendicular to the side panel and fix the shelves of the end unit - all but the bottom one
- 2 - Die Rückwand senkrecht zur Seitenwand stellen und die Fächer (alle außer der unterste) befestigen

- 3 - Applicare i reggipiani A al pannello frontale facendo attenzione al verso del pannello (vedi dettaglio sotto).
- 3 - Insert the shelf supports (A) into the front panel minding about the asymmetry of the drilling (see the drawing herewith)
- 3 - Die Halterungen der Fächer (A) in der Frontplatte einsetzen, bitte über die Asymmetrie Der Bohrung bemerken (siehe hiermit die Zeichnung)

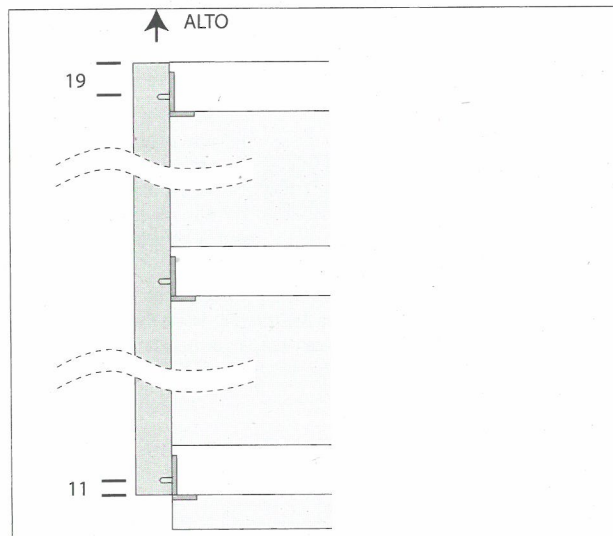

- 4 - Posizionare il pannello frontale e fissarlo ai reggipiani facendolo scorrere dal basso verso l'alto e procedendo subito a bloccare i reggipiani (i ripiani sostengono il pannello frontale).
- 4 - Place the front panel and fix it to the shelf supports by sliding it from the bottom upwards. Secure immediately the shelf supports (they support the front panel)
- 4 - Die Front stellen, von unten nach oben schieben um sie an der Halterungen der Fächer zu befestigen. Die Halterungen sofort sichern (sie halten die Frontplatte)
- 5 - Applicare i piedini in dotazione sul ripiano inferiore ed agire sulla regolazione. Posizionare il ripiano inferiore a terra.
- 5 - Insert the feet supplied into the bottom shelf and adjust. Place the bottom shelf to the ground.
- 5 - Die gelieferte Füße in den unteren Fach einsetzen und verstellen, dann den Fach an den Boden setzen



Università di Udine



Dalum
dalum.it

novamobili.it

Novamobili S.p.a.
Via Pascoli 14, Pieve di Soligo (TV), 31053, Italia
Tel + 39 0438 9868, Fax + 39 0438 986999
novamobili@novamobili.it
