

**cattelan
italia**

**WISH
WISH S
WISH MAGNUM**

***ISTRUZIONI DI MONTAGGIO ASSEMBLING INSTRUCTIONS MONTAGEANLEITUNG
INSTRUCTIONS DE MONTAGE INSTRUCCIONES DE MONTAJE***

Cattelan Italia spa si riserva di apportare, senza preavviso, modifiche nei materiali, nei rivestimenti, nelle finiture e nei disegni dei prodotti presentati in questo catalogo. Le textures ed i colori dei materiali e delle finiture hanno valore indicativo in quanto soggetti alle tolleranze dei processi di stampa.

Cattelan Italia spa reserves the right to change, without previous notice, materials, covers, finishes and drawings of the products presented in this catalogue. The textures and colours of materials and finishes are indicative as they are depending on the tolerances of the printing process.

Cattelan Italia spa behält sich vor, ohne Vorankündigung, Veränderungen an den Materialien, Bezügen, Finish und Zeichnungen der in diesem Katalog vorgestellten Produkte vorzunehmen. Die Texturen und Farben der Materialien und Finish haben einen hinweisenden Wert, da sie von den Toleranzen im Druckprozess abhängig sind.

Cattelan Italia spa se réserve le droit d'apporter, sans préavis, des modifications au niveau des matériaux, des revêtements, des finitions et du design des produits présentés dans ce catalogue. Les textures et les couleurs des matériaux et des finitions sont une valeur indicative parce-que ils changent selon la tolérance aux procédés d'imprimerie.

Cattelan Italia spa se reserva el derecho de aportar modificaciones de dibujo, materiales, acabados y tapicerías, sin que esté obligada a dar aviso anticipado. Las textures y los colores de los materiales y de los acabados tienen solo un valor indicativo porque están sujetos a la tolerancia en los procesos de imprenta.

IMPORTANTE: Riporre per eventuali consultazioni future!!!!

IMPORTANT: File for future consultation!!!!

WICHTIG: Bitte aufbewahren für eventuelle spätere Nachfragen!!!!

IMPORTANT: A conserver pour les futurs besoins de référence!!!!

¡IMPORTANTE: Guardar para consultas posteriores!

WISH

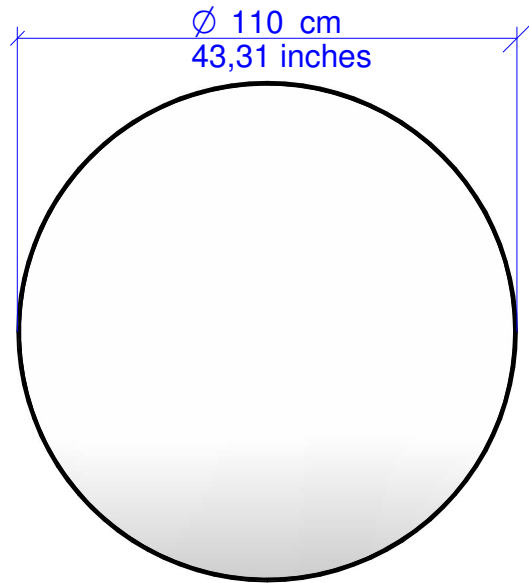
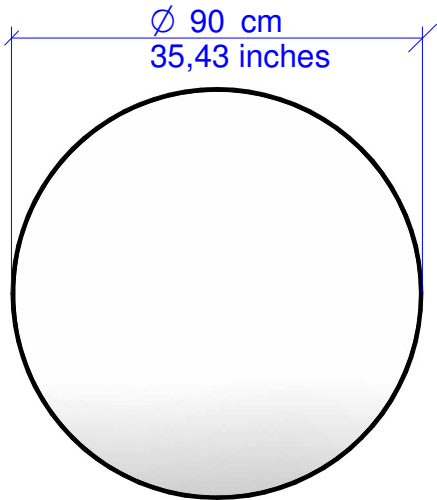
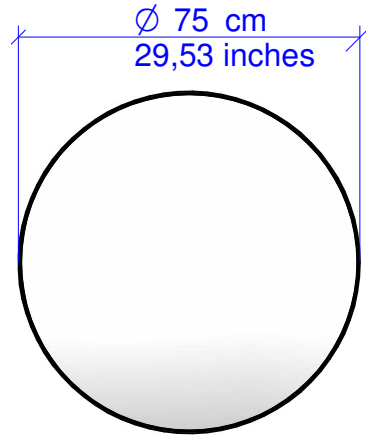
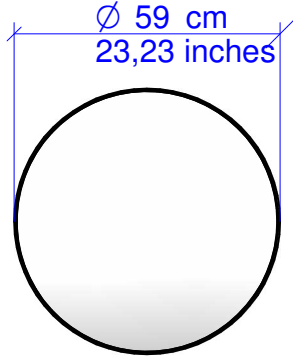
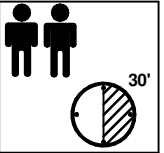

n° 02 cod. 216818400499.

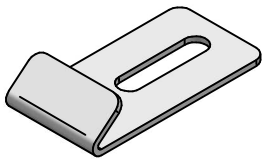

n° 02 tassello SX8.

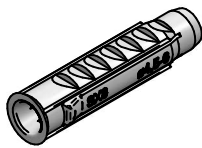

n° 02 TPS croce 4,5x60 ZB.

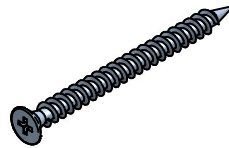

n° 02 rondella ø6x18 ZB.

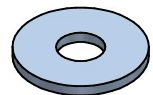

n° 04 feltro 25x20 sp.1 morbido nero.

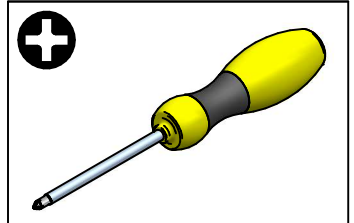

WISH S

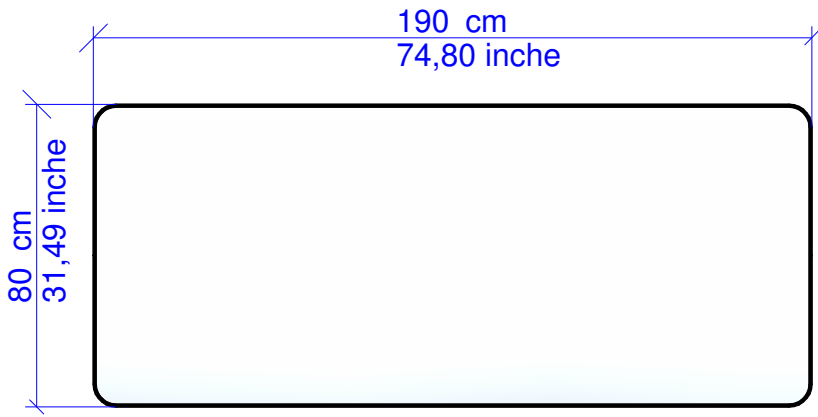
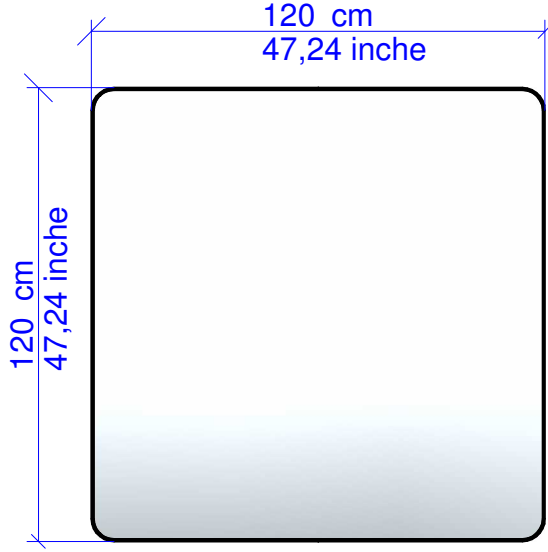
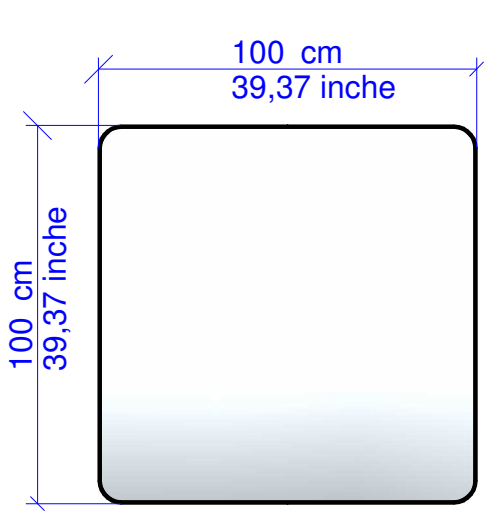

n° 02 cod. 216818400499.

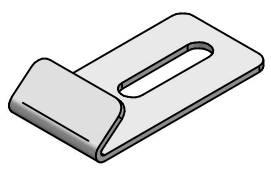

n° 02 tassello SX8.

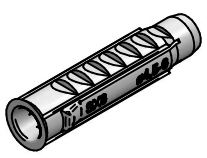

n° 02 TPS croce 4,5x60 ZB.

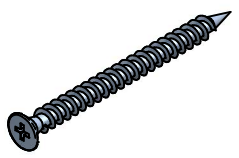

n° 02 rondella ø6x18 ZB.

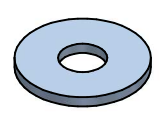

n° 04 feltro 25x20 sp.1 morbido nero.

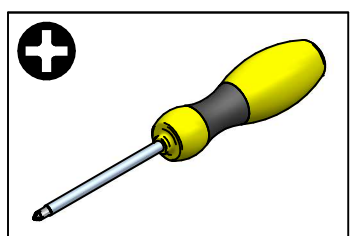
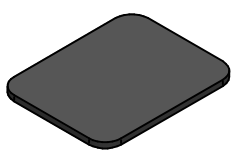

WISH MAGNUM

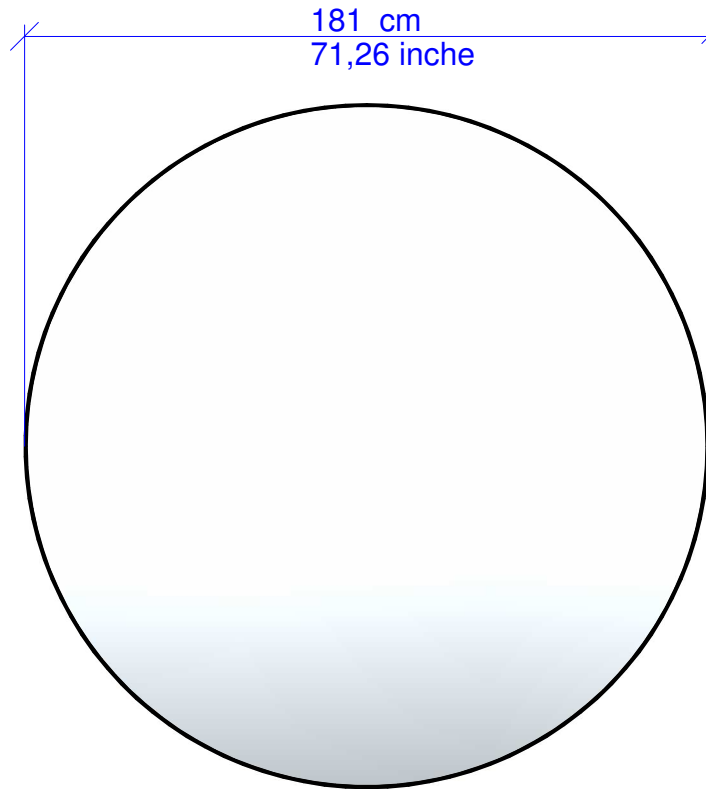
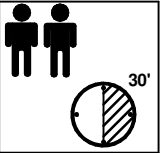

n° 02 cod. 216818400499.

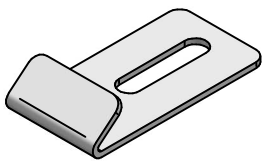

n° 02 tassello SX8.

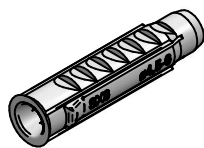

n° 02 TPS croce 4,5x60 ZB.

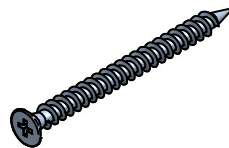

n° 02 rondella ø6x18 ZB.

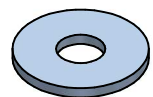

n° 04 feltro 25x20 sp.1 morbido nero.

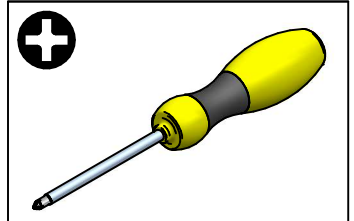

WISH

1 Facoltativo!!!!
Opzionale!!!!

**IMPORANTE!!!! - VERY IMPORTANT!!!!
WICHTIG!!!! - TRÈS IMPORTANT!!!!
¡MUY IMPORTANTE!**

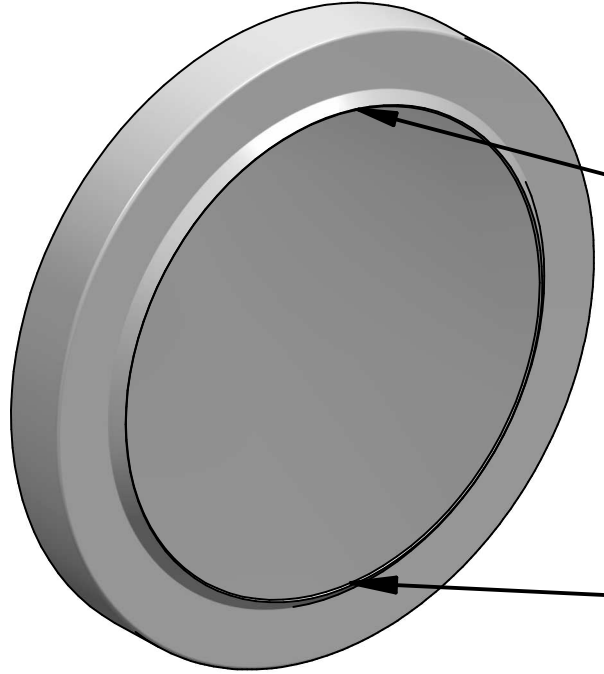

Parte dove si prevede il fissaggio a muro.
Part which will be fixed to the wall.
Wandbefestigungsteil.
Une partie qui sera fixé au mur.
El montaje en pared parte.

Protezione
Protection
Den Schutz
Protección

x2

n° 04 feltro 25x20 sp.1 morbido nero.

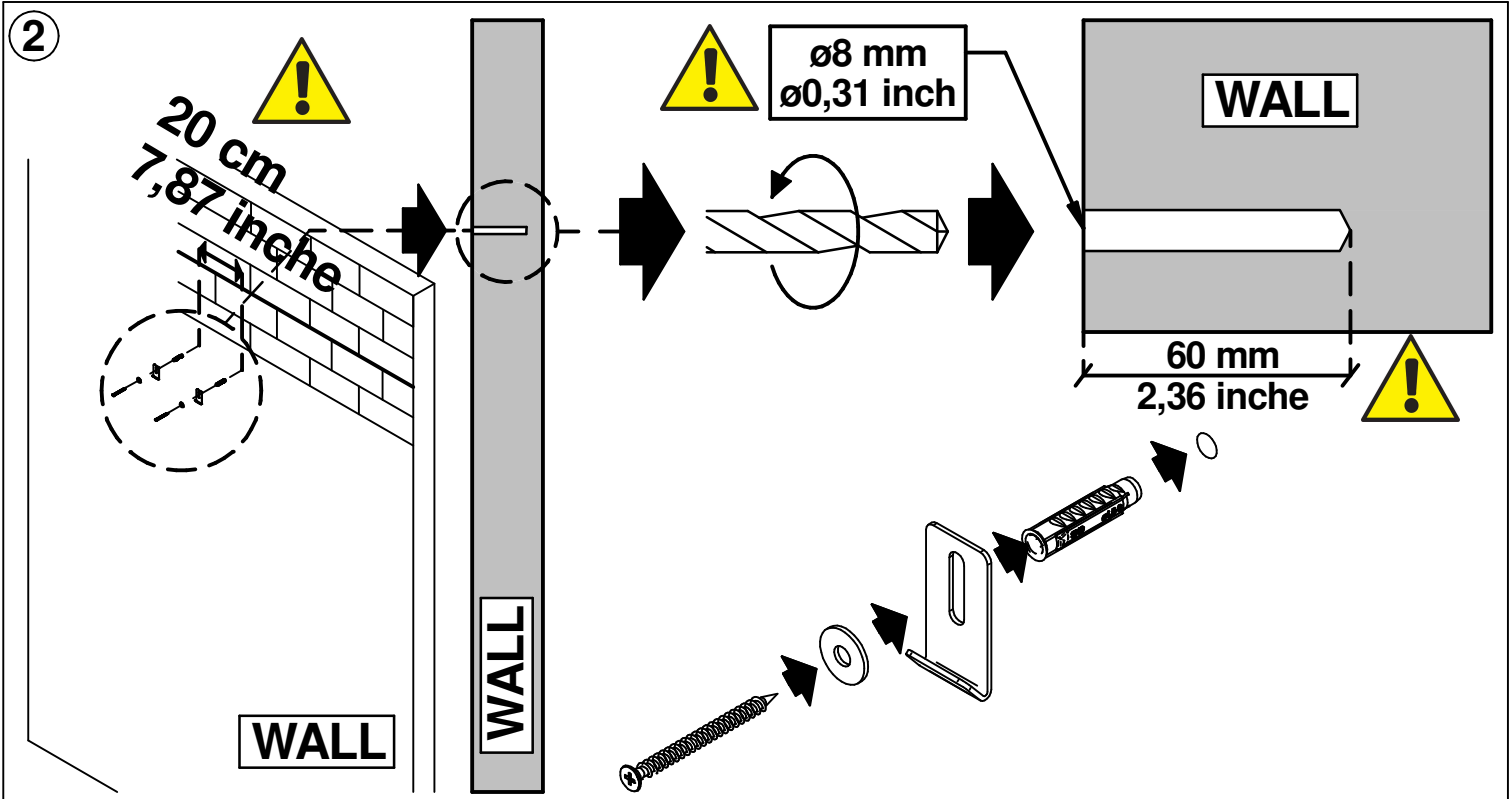

n° 02 cod. 216818400499.

n° 02 tassello SX8.

n° 02 TPS croce 4,5x60 ZB.

n° 02 rondella $\varnothing 6 \times 18$ ZB.

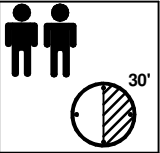

Possibilità di fissaggio a muro.
Possibility of wall mounting.

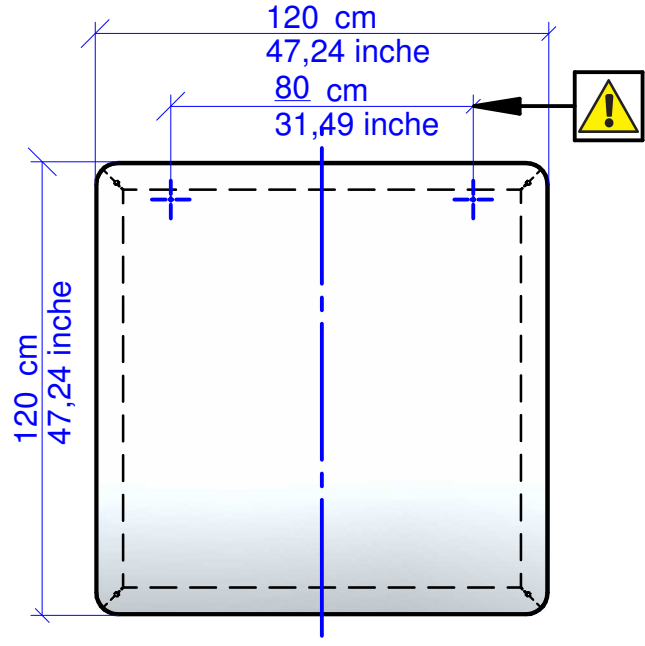
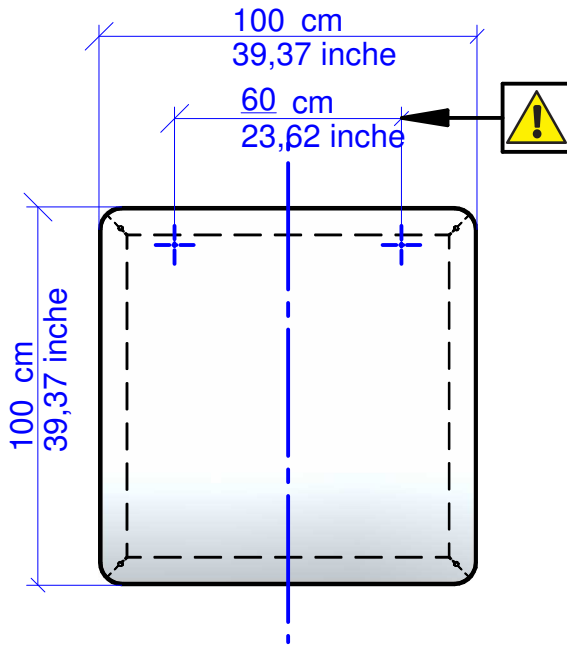

VERTICALE
VERTICAL

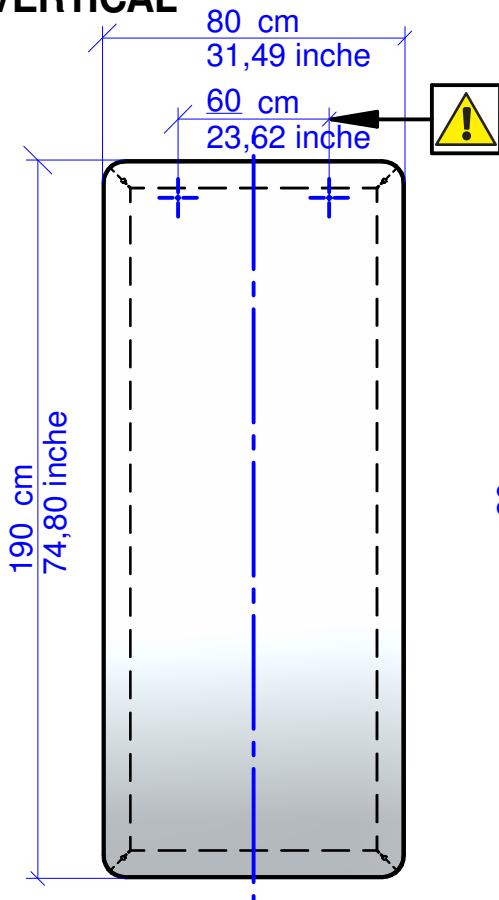

ORIZZONTALE
HORIZONTAL

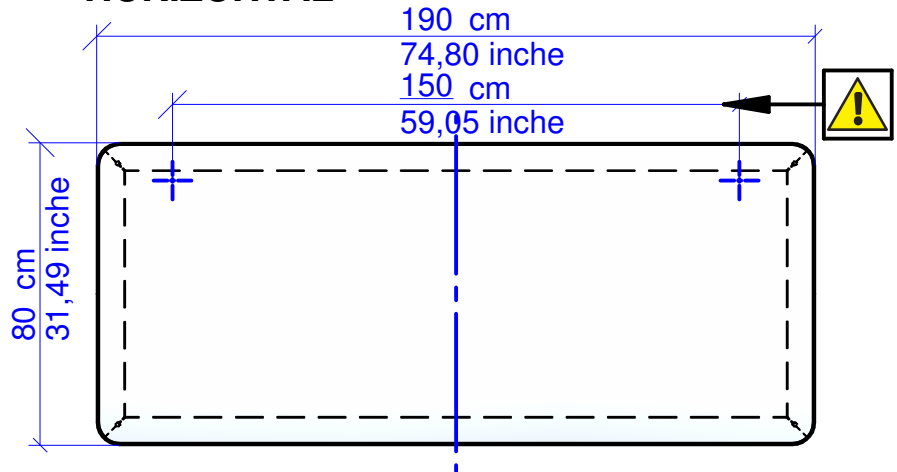

IMPORTANTE!!!! - VERY IMPORTANT!!!!
WICHTIG!!!! - TRÈS IMPORTANT!!!!
¡MUY IMPORTANTE!



Tenere i fissaggi più larghi possibili.
Keep the fixings as wide as possible.

n° 02 cod. 216818400499.

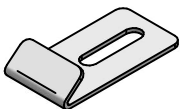

n° 02 tassello SX8.



n° 02 TPS croce 4,5x60 ZB.



n° 02 rondella ø6x18 ZB.



WISH S

1 Facoltativo!!!!
Opzional!!!!

**IMPORANTE!!!! - VERY IMPORTANT!!!!
WICHTIG!!!! - TRÈS IMPORTANT!!!!
¡MUY IMPORTANTE!**

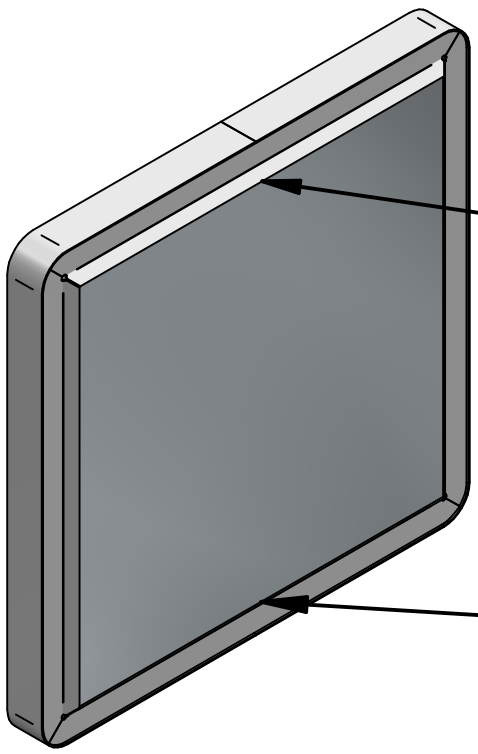

Parte dove si prevede il fissaggio a muro.
Part which will be fixed to the wall.
Wandbefestigungsteil.
Une partie qui sera fixé au mur.
El montaje en pared parte.

Protezione
Protection
Den Schutz
Protección

x2

n° 04 feltro 25x20 sp.1 morbido nero.

2

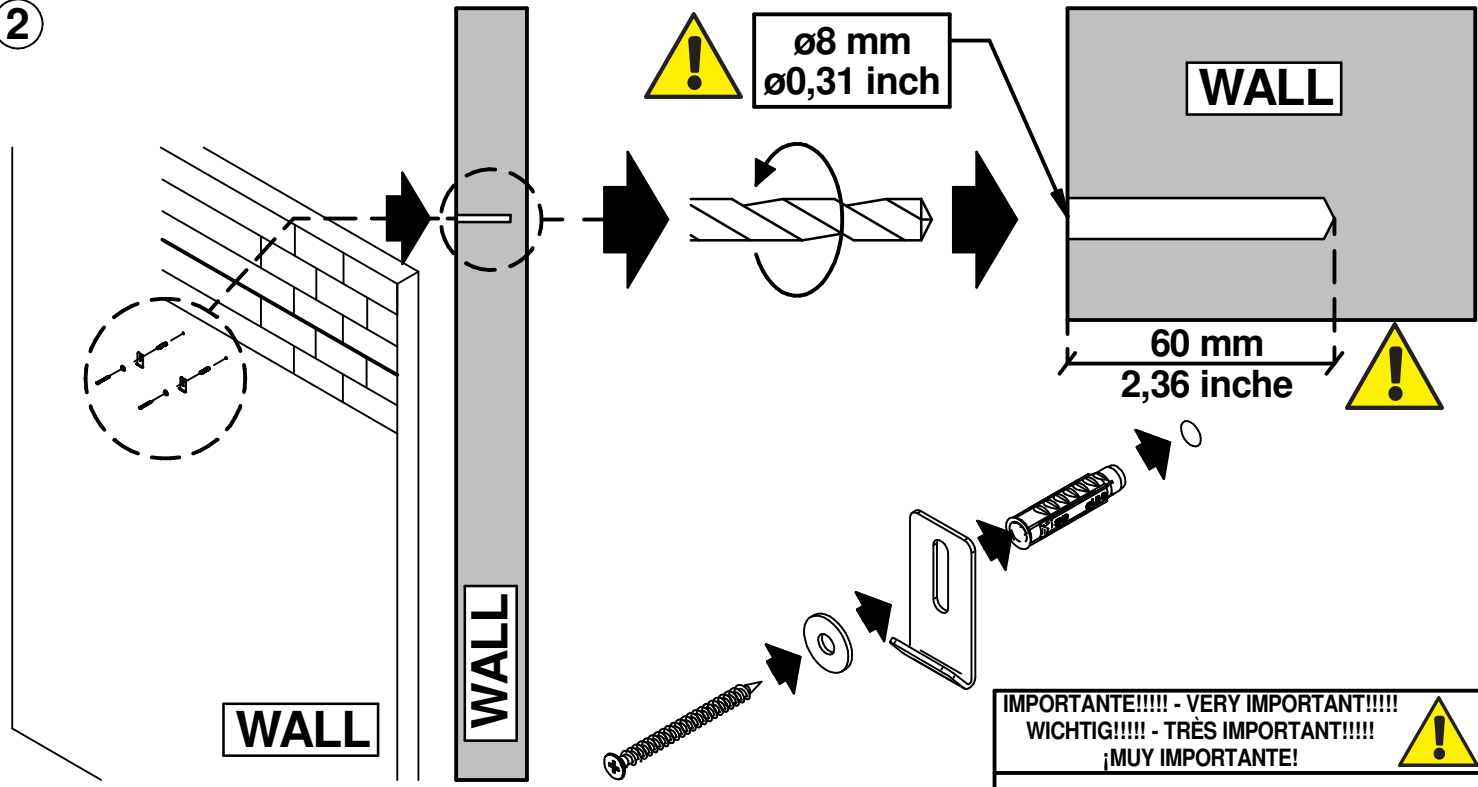

**IMPORANTE!!!! - VERY IMPORTANT!!!!
WICHTIG!!!! - TRÈS IMPORTANT!!!!
¡MUY IMPORTANTE!**

**Tenere i fissaggi più larghi possibili.
Keep the fixings as wide as possible.**

n° 02 cod. 216818400499.

n° 02 tassello SX8.

n° 02 TPS croce 4,5x60 ZB.

n° 02 rondella ø6x18 ZB.

WISH MAGNUM

1 Facoltativo!!!! Opzional!!!!

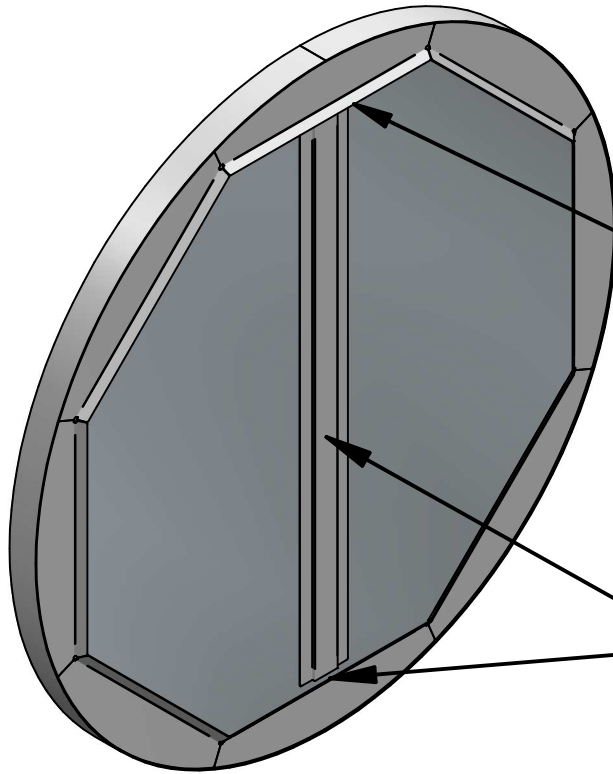

**IMPORANTE!!!! - VERY IMPORTANT!!!!
WICHTIG!!!! - TRÈS IMPORTANT!!!!
¡MUY IMPORTANTE!**

Parte dove si prevede il fissaggio a muro.
Part which will be fixed to the wall.
Wandbefestigungsteil.
Une partie qui sera fixé au mur.
El montaje en pared parte.

Protezione
Protection
Den Schutz
Protección

 **x4**

n° 04 feltro 25x20 sp.1 morbido nero.



2

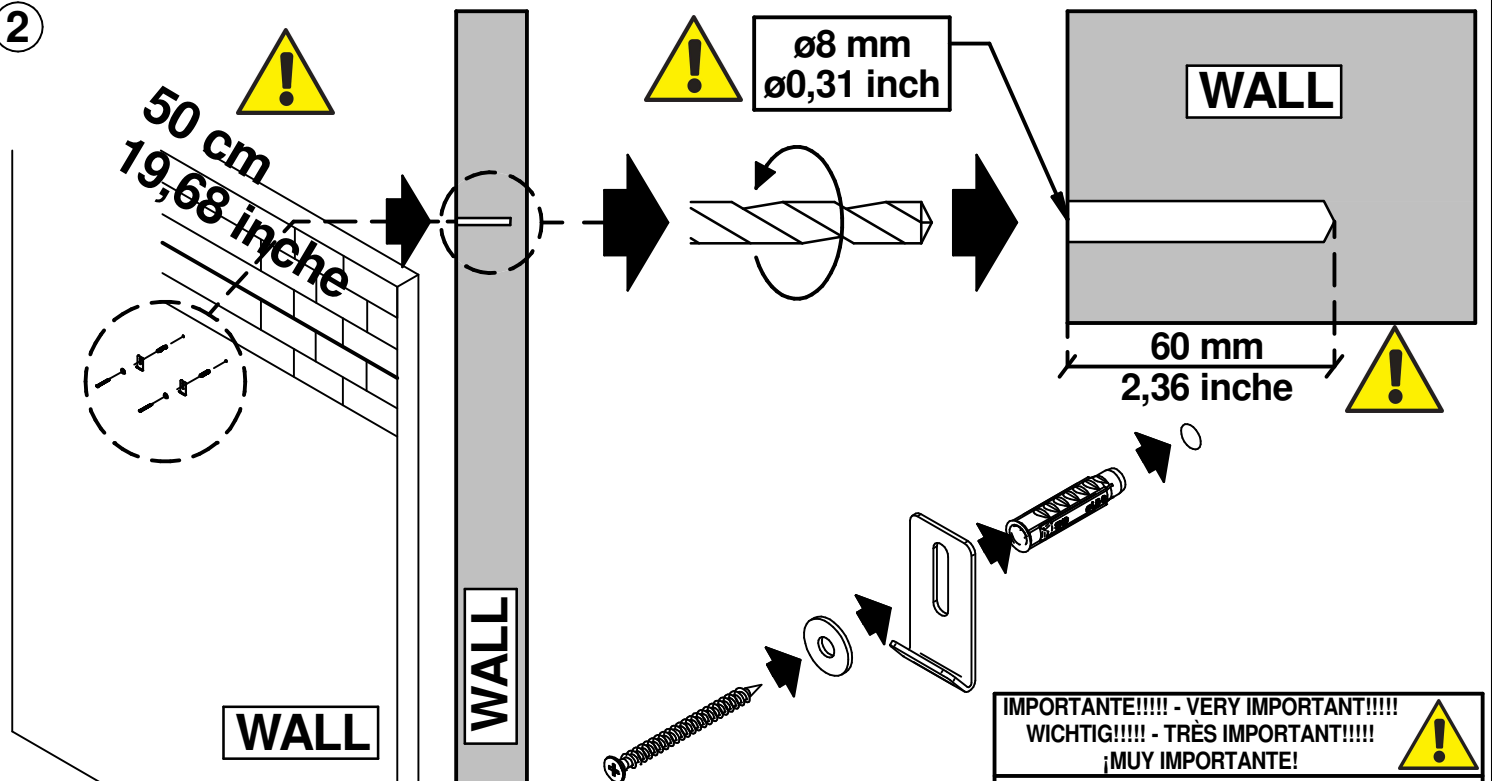

n° 02 cod. 216818400499.

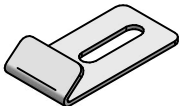

n° 02 tassello SX8.



n° 02 TPS croce 4,5x60 ZB.



n° 02 rondella ø6x18 ZB.



**Tenere i fissaggi più larghi
possibili.
Keep the fixings as wide as
possible.**

AVVERTENZE PER IL CLIENTE FINALE



USO

Il prodotto é destinato per l'utilizzo all'interno delle abitazioni con l'uso per il quale é stato realizzato.



REALIZZAZIONE

Piccole irregolarità di riflessione sulla base sono dovute alla lavorazione manuale del prodotto.

MANUTENZIONE

La pulizia delle parti in acciaio va fatta utilizzando detergenti specifici appositamente studiati e facilmente reperibili in commercio adatti alla pulizia dell'acciaio. Non vanno assolutamente utilizzati strumenti metallici appuntiti o panni abrasivi per eliminare eventuali residui di sporco presenti sulla superficie del prodotto, in quanto possono danneggiare la superficie stessa. Non vanno assolutamente utilizzati detergenti che contengano cloro o a base di acido cloridrico, acido muriatico o prodotti anticalcare in quanto andrebbero ad alterare la brillantezza del prodotto.



SMALTIMENTO

Una volta dismesso, il prodotto od i suoi componenti non vanno dispersi nell'ambiente ma conferiti ai sistemi pubblici di smaltimento.

INSTRUCTIONS FOR THE END CUSTOMER



USE

The product is intended to be used in the inside and for the purposes it was created for.



ACCOMPLISHMENT

Small reflection's irregularities on the base are due to manual processing.

MAINTENANCE

The stainless-steel parts cleaning can be done with the use of specific detergents for the stainless-steel cleaning which can be easily found on the market. It is recommended not to use metal sharp tools or abrasive clothes to eliminate dirt from the surface, because they could damage the same. Do not absolutely use detergents containing chlorine, muriatic acid, hydrochloric acid or descale detergents which can damage the surface brilliance.



DISPOSAL

Once discarded, neither the product nor its components should be dispersed in the environment, but rather consigned to public disposal systems.

HINWEISE FÜR DEN ENDKUNDEN



NUTZUNG

Das Produkt ist nur für den Innenbereich gedacht. Der Tisch wurde hergestellt, nur als Esstisch genutzt zu werden.



AUSFÜHRUNG

Kleine Unregelmäßigkeiten der Reflexion auf der Basis sind nicht zu vermeiden, da das Teil per Hand hergestellt wird.

WARTUNG

Für die Reinigung des Stahls nur entwickelte Produkte für die Reinigung von Stahl verwenden. Diese Produkte sind im Handel erhältlich. Niemals scharfe Werkzeuge aus Metall, spitzen Instrumente oder Schleifmittel für die Reinigung der Oberfläche verwenden. Diese Produkte können die Oberfläche beschädigen. Niemals Chemikalien mit chlorhaltigen Salzsäure, Salzsäure oder Kalk-Produkte für die Reinigung verwenden. Diese Produkte können der Glanz beschädigen.



ENTSORGUNG

Nach der Aussonderung ist das Produkt und seine Bestandteile nicht selbständig im Freien zu entsorgen, sondern der städtischen Müllabfuhr zu übergeben.

INSTRUCTIONS POUR LE CLIENT FINAL



UTILISATION

Le produit est destiné pour une utilisation à l'intérieur des habitations.



CONSTRUCTION

Les petites irrégularités de réflexion sur la base sont dues à une fabrication manuelle.

MANUTENTION

Nettoyez les parties en acier inox avec des détergents spécifiques, spécialement conçues et étudiés pour le nettoyage de l'acier et faciles à trouver dans le marché.

Il ne faut pas absolument utiliser des outils pointus ou des chiffons abrasifs pour éliminer des possibles restes sur la surface du produit, parce qu'ils peuvent endommager la surface même. Ne pas utiliser des détergents contenant du chlore, acide chlorhydrique, acide muriatique ou produits anticalcaire qui peuvent altérer le brillant du produit.



ECOULEMENT

Une fois disloqué, le produit ou ses composants ne doivent pas être dispersés dans la nature mais confiés aux décharges publiques.

INSTRUCCIONES PARA EL CLIENTE FINAL



USO

El producto está destinado para su uso dentro del hogar, a los fines por los cuales fue creado.



CONSTRUCCIÓN

Pequeñas irregularidades de reflexión en la base están causadas por la producción manual.

MANTENIMIENTO

La limpieza de las partes en acero se realiza con detergentes específicos, especialmente diseñados y fáciles de obtener en el mercado, adecuados para la limpieza de acero. No utilizar en cualquier forma instrumentos de metal afilados o telas abrasivas para eliminar cualquier resto de suciedad en la superficie del producto, ya que pueden dañar la superficie misma. No utilizar en cualquier forma limpiadores a base de cloro o que contienen ácido clorhídrico, ácido muriático o productos anticalcáreos ya que pueden alterar el brillo del producto.



ELIMINACIÓN DE DESECHOS

Una vez desechado, el producto o sus componentes no se tienen que abandonar en el entorno sino entregar al sistema público de recogida de basuras.

Cattelan Italia spa si riserva di apportare, senza preavviso, modifiche nei materiali, nei rivestimenti, nelle finiture e nei disegni dei prodotti presentati in questo catalogo. Le textures ed i colori dei materiali e delle finiture hanno valore indicativo in quanto soggetti alle tolleranze dei processi di stampa.

Cattelan Italia spa reserves the right to change, without previous notice, materials, covers, finishes and drawings of the products presented in this catalogue. The textures and colours of materials and finishes are indicative as they are depending on the tolerances of the printing process.

Cattelan Italia spa behält sich vor, ohne Vorankündigung, Veränderungen an den Materialien, Bezügen, Finish und Zeichnungen der in diesem Katalog vorgestellten Produkte vorzunehmen. Die Texturen und Farben der Materialien und Finish haben einen hinweisenden Wert, da sie von den Toleranzen im Druckprozess abhängig sind.

Cattelan Italia spa se réserve le droit d'apporter, sans préavis, des modifications au niveau des matériaux, des revêtements, des finitions et du design des produits présentés dans ce catalogue. Les textures et les couleurs des matériaux et des finitions sont une valeur indicative parce-que ils changent selon la tolérance aux procédés d'imprimerie.

Cattelan Italia spa se reserva el derecho de aportar modificaciones de dibujo, materiales, acabados y tapicerías, sin que esté obligada a dar aviso anticipado. Las textures y los colores de los materiales y de los acabados tienen solo un valor indicativo porque están sujetos a la tolerancia en los procesos de imprenta.

IMPORTANTE: Riporre per eventuali consultazioni future!!!!

IMPORTANT: File for future consultation!!!!

WICHTIG: Bitte aufbewahren für eventuelle spätere Nachfragen!!!!

IMPORTANT: A conserver pour les futurs besoins de référence!!!!

¡IMPORTANTE: Guardar para consultas posteriores!

**cattelan
italia**

CATTELANITALIA.COM



CATTELAN ITALIA SPA – via pilastri 19 – 36010 Carré / Vicenza – Italy
phone +39 0445 318711 - fax +39 0445 314289 - email: info@cattelanitalia.com