

GAUTIER

REF.A06 - DIMIX Blanc / Gris

REF.A26 - DIMIX Chêne structuré

REF. 606 - LIT HAUT ULTRACOMPACT 90 X 200

A

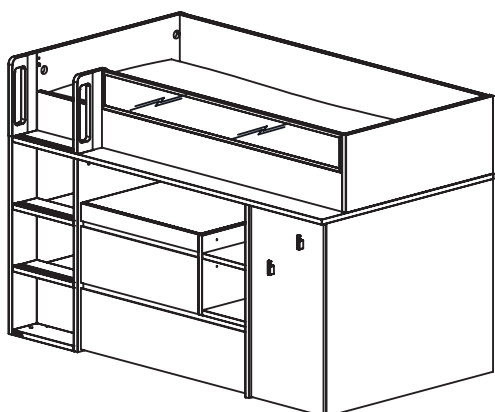

B

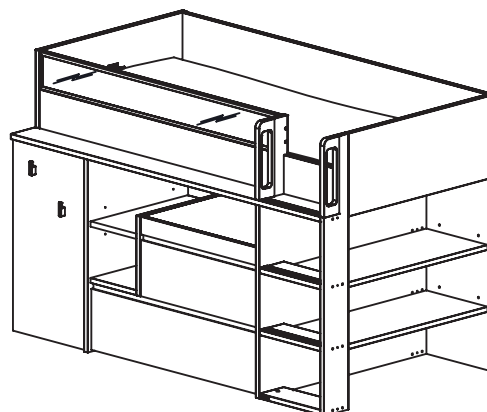

Conforme aux exigences de sécurité / In accordance of safety requirements / Conforme a la normativa de seguridad / Conform aan de veiligheidsnormen / Gemäss an der Sicherheits Anforderungen / Conforme alle esigenze di sicurezza / В соответствии с требованиями безопасности / Conforme com os requisitos de segurança

NF-EN 747-1 (2012) + A1:2015

- FR** Nous vous remercions d'avoir choisi ce meuble. Pour garantir une satisfaction totale, il est très important que vous suiviez phase par phase les instructions de montage.
- GB** Thank you for buying this furniture. For your total satisfaction, it is very important that you follow the assembly instructions step by step.
- ES** Le agradecemos que haya elegido este mueble. Para garantizar una total satisfacción, es muy importante que siga todos los pasos de las instrucciones de montaje.
- NL** Wij danken u dat u voor dit meubel gekozen heeft. Voor een optimaal gebruik van het meubel is het van het grootste belang dat u stap voor stap de montage-instructies volgt.
- DE** Wir danken Ihnen, dass Sie sich für dieses Möbelstück entschieden haben. Bitte befolgen Sie die Montageanleitung genau, damit Sie mit dem fertigen Möbel vollkommen zufrieden sind.
- IT** Vi ringraziamo per aver scelto questo mobile. Per garantire una totale soddisfazione, è molto importante che seguiate fase per fase le istruzioni di montaggio.
- RU** Спасибо за ваш выбор. Для правильной сборки необходимо внимательно прочитать инструкцию.
- PT** Muito obrigado por ter escolhido este móvel. Para garantir uma satisfação total, é muito importante que siga passo-a-passo as instruções de montagem.

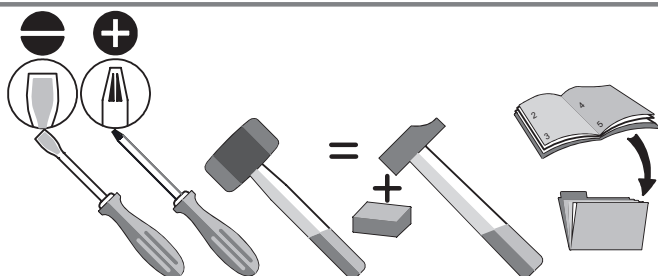

EXPERT



X1

6h00

X2

3h00

NOVICE

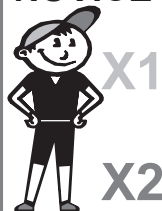

X1

12h00

X2

6h00

Certaines phases de montage nécessitent l'intervention de 2 personnes
Some assembly phase requires the intervention of 2 people

N° Série :

GAUTIER FRANCE BP 10 85510 LE BOUPERE FRANCE



contact@gautier.fr

Instructions de montage et d'utilisation : - Bien suivre les instructions d'utilisation et respecter les conseils spécifiques donnés.

- Vérifier la présence et l'état de la quincaillerie et des pièces avant montage.
- Utiliser uniquement l'outillage fourni ou préconisé.
- Les meubles à monter doivent être assemblés par un adulte et jamais par un enfant.
- Tenir éloignés les jeunes enfants lors du montage (présence de petites pièces pouvant être ingérées).
- Lorsque le meuble doit être fixé à un support, adapter la quincaillerie à ce support.
- Un mauvais montage, calage ou manutention peut entraîner une fragilisation des assemblages et/ou des pièces.
- Vérifier que le meuble ne présente aucun défaut ou anomalie fonctionnelle.
- Vérifier que le meuble est de niveau (ne pas hésiter à mettre des cales pour assurer le bon fonctionnement et la longévité des portes et tiroirs).
- Pour préserver l'environnement, trier les emballages et les déposer dans un endroit prévu pour leur recyclage (déchetterie).

Conseils d'utilisation : - Ne pas déplacer un meuble chargé.

- Pour un meuble sur roulettes, éviter les obstacles sur le sol lors du déplacement et bloquer les roulettes verrouillables avant utilisation.
- Ne pas mettre d'objets lourds ou encombrants dans une chambre d'enfant. Placer les objets sur une surface non accessible à l'enfant (de préférence au centre du meuble).
- Ce meuble vous donnera entière satisfaction dans des conditions habituelles d'utilisation (Température de 15 à 25°C / Humidité de 50 à 70%).
- **IMPORTANT :** Toute modification apportée au meuble ou tout montage différent, non prévus par le fabricant, décline le produit de son usage initial et engage alors la responsabilité de celui qui réalise cette transformation.
- **AVERTISSEMENT :** Attention au danger de placer le meuble à proximité de flammes nues, d'un foyer ouvert ou d'autres sources de forte chaleur, comme les appareils de chauffage électrique, les appareils de chauffage à gaz, etc.

Matériaux : - Tous nos produits sont fabriqués avec des panneaux à base de bois classés E1, selon la norme EN 13986, ce qui garantit une teneur en formaldéhyde inférieure ou égale à 8 mg pour 100g. De plus, pour ce produit, les panneaux de particules d'épaisseur supérieure ou égale à 16 mm vont au-delà des exigences du classement E1 et garantissent une teneur en formaldéhyde inférieure ou égale à 4 mg pour 100g.

- Les panneaux de particules sont revêtus papier décor.

Entretien : - Nettoyer le meuble exclusivement à l'aide d'un chiffon doux imbibé d'eau savonneuse et l'essuyer avec un chiffon sec.

- Dans le cas d'un lit avec un panneau sommier, retourner le matelas régulièrement pour assurer une meilleure ventilation.

Garantie : - Si, malgré tous nos contrôles, vous constatez une anomalie, nous vous remercions de préciser sa nature, le numéro de la ou les pièces défectueuses ainsi que les références et "N° de série" de votre meuble auprès de votre distributeur.

Conseils spécifiques : Lit Haut

- AVERTISSEMENT** Les lits surélevés et lit supérieur des lits superposés ne conviennent pas pour les enfants de moins de six ans en raison du risque de blessures liées à des chutes
- AVERTISSEMENT** S'ils ne sont pas utilisés correctement, les lits superposés et les lits surélevés peuvent présenter un sérieux risque de blessure par étranglement. Ne jamais attacher ou suspendre des éléments à des parties du lit superposé qui ne sont pas destinés à être avec ledit lit. Ces éléments comprennent, sans toutefois s'y limiter, les cordes, les ficelles, les cordons, les crochets, les ceintures et les sacs.
- AVERTISSEMENT** Les enfants peuvent se retrouver coincés entre le lit et un mur, une partie d'un toit incliné, le plafond, des meubles adjacents (par exemple, des placards) ou autres. Pour éviter tout risque de blessure grave, la distance entre la barrière de sécurité supérieure et les éléments environnants ne doit pas dépasser 75 mm ou doit être supérieure à 230 mm.
- AVERTISSEMENT** Ne pas utiliser le lit superposé ou le lit surélevé si une pièce de la structure est manquante ou cassée.
- REF. A06.606 : utiliser un matelas de dimension 198 x 88 x épaisseur maxi 20 cm.
- Il est nécessaire de ventiler la pièce afin de maintenir un niveau peu élevé d'humidité et d'empêcher le développement de moisissure dans le lit et autour de celui-ci.
- Tous les lits superposés ou surélevés destinés à être assemblés par une personne autre que le fabricant ou son représentant doivent comprendre des instructions de montage incluant une liste des pièces fournies et le détail des outils nécessaires pour monter le lit.
- Un marquage sur lit indique la hauteur maxi du matelas.
- Vérifier régulièrement que tous les éléments de fixation sont correctement serrés.

Assembly and use instructions : - Follow the instructions for use carefully and observe the specific recommendations provided.

- Before the assembly, check if hardware and pieces are included and in good state
- Use only the tools furnished or recommended
- The assembly of furniture must be carried out by an adult and never by a child
- Keep young children at large distance from the place of assembly (some small pieces may be swallowed)
- When the furniture must be fixed to a support, adapt the hardware to this support
- A problem in the assembly, the setting and adjustment, or the handling of the furniture may lead to weaken the pieces and or parts of the furniture
- Verify that the piece of furniture does not have any default or functional anomaly
- Verify that the piece of furniture is level (do not hesitate to place wedges to ensure that the doors and drawers function correctly and last longer)
- To protect the environment, sort packaging and place them in the appropriate bin for recycling (waste sorting center)

Direction for use : - Do not move a loaded piece of furniture

- For a piece of furniture on castors, avoid impediments on the ground when moving it and put the brakes on after moving it.
- Do not place heavy or cumbersome objects in a child's bedroom. Place the objects on a surface that the child cannot reach (preferably at the centre of the furniture).
- This piece of furniture will give you entire satisfaction in the customary usage conditions (temperature from 15 to 25°C / Humidity from 50 to 70%).
- **IMPORTANT :** Any alteration made to the furniture or any difference in the assembly, not intended by the manufacturer, may make the product unfit for its initial use and is the sole responsibility of the person making the alteration.
- **WARNING :** Be careful not to place the piece of furniture close to flames, and open firebox or any other sources of high temperature, such as the electric heating appliances, gaz heating devices, etc.

Material :

- All our products are fabricated with wooden panels classified E1, according to the EN 13986 regulations, which guarantees a formaldehyde content lower or equal to 8 mg for 100g. Moreover, for this product, particle panels with a thickness higher or equal to 16 mm go beyond this E1 classification demands and have a guaranteed formaldehyde content lower or equal to 4 mg for 100g.
- Particle panels are covered with a paper film.

Maintenance : - Clean our furniture using only a soft cloth rung out in soapy water, and then polish it with a dry duster

- If you have bought a bed with a solid mattress base, we recommend that you turn the mattress regularly to keep it aired.

Guarantee : - If, despite all our verifications, you notice an anomaly, kindly describe the nature of the anomaly, the number of the defective item or items, as well as the your distributor's reference number and "N° de série" for your piece of furniture.

Specific advices : High Sleepers

- WARNING** Raised beds and the top bunk of bunk beds are not suitable for children under the age of six due to the risk of injury as a result of falls.
- WARNING** If not used correctly, bunk beds and raised beds can pose a serious risk of injury through strangulation. Never attach or hang elements from parts of the top bunk that are not designed to be used with said bed. These elements include but are not limited to rope, string, cord, hooks, belts and bags.
- WARNING** Children may become trapped between the bed and a wall, part of a sloped roof, the ceiling, adjacent furniture (e.g. cupboards) or others. In order to avoid all risk of serious injury, the distance between the upper safety barrier and surrounding elements must not exceed 75mm or must be greater than 230mm.
- WARNING** Do not use the top bunk or the raised bed if a piece of the structure is missing or broken.
- REF. A06.606 : use a 198 x 88 mattress with a maximum thickness of 20 cm.
- The room needs to be ventilated to maintain a level of humidity that is not too high and avoid mould developing in and around the bed.
- All bunk beds and raised beds designed to be assembled by someone other than the manufacturer or a representative thereof must come with assembly instructions, including a list of the parts provided and details of the tools required to assemble the bed.
- There is a mark on the bed to indicate the maximum height of the mattress.
- Check the fastening elements regularly to make sure these are tightly fastened.

Instrucciones de montaje y uso: - Seguir correctamente las instrucciones y respetar los consejos de uso específicos.

- Verificar la presencia y el buen estado de toda la quincalla y los elementos antes el montaje.
- Usar las herramientas proporcionadas o recomendadas.
- Los muebles debe montarlos un adulto y en ningún caso un niño.
- Mantener los niños lejos durante el montaje (presencia de pequeños elementos que puedan ser ingeridos).
- Cuando el mueble debe ser fijado sobre un soporte, adaptar la quincalla a este soporte.
- Un montaje, apuntalamiento o manipulación incorrecto puede debilitar el montaje y/o los elementos.
- Verificar que el mueble no tiene ningún defecto o anomalía de funcionamiento.
- Verificar que el mueble esta nivelado (no dude en colocar tacos para asegurar el buen funcionamiento y la longevidad de las puertas y de los cajones).
- Para preservar el medio ambiente, separe los embalajes y deposítelos en el lugar previsto para su reciclaje (vertedero).

Consejos de uso: - No desplazar un mueble cargado.

- Para un mueble con ruedas, pagar atención a los obstáculos al piso y no olvidar poner los frenos después del movimiento, verificar que todos los mecanismos están bien cerrados antes del uso.
- No colocar objetos pesados o voluminosos en un dormitorio de niño. Los objetos tendrán que colocarse sobre una superficie a la que no tenga acceso el niño y deberán instalarse preferiblemente en el centro del mueble.
- Este mueble le proporcionaran total satisfacción en condiciones habituales de uso (Temperatura de 15 a 25°C / Humedad del 50 al 70%).
- **IMPORTANTE** : Cualquier modificación realizada en el mueble, no prevista por el fabricante, cambia el uso inicial del producto y compromete la responsabilidad de la persona que realiza esta transformación.
- **ADVERTENCIAS** : Cuidar de ubicar el mueble cerca de las flamas, de hogares abiertos, o de aparatos de calefacción eléctricos, de gas, etc.

Materiales: - Todos nuestros productos están fabricados con paneles a base de madera clasificados E1, según la norma EN 13986, lo que garantiza una cantidad de formaldehído inferior o igual a 8 mg por 100g. Además, para este producto, los paneles de partículas de grosor superior o igual a 16 mm van más allá de las exigencias de la clasificación E1 y garantizan una cantidad de formaldehído inferior o igual a 4 mg por 100 g.

- Los paneles de partículas están revestidos de papel para forrar.

Mantenimiento :

- Limpiar el mueble exclusivamente con un trapo suave empapado de agua y jabón y secarlo con un trapo seco.
- En el caso de una cama con un panel de soporte de colchón, para asegurar una mejor ventilación, se aconseja darle la vuelta al colchón con frecuencia.

Garantía : - Si pese a todos nuestros controles detectas una anomalía, te agradecemos que le indiques a tu distribuidor su naturaleza, el número de la o de las piezas defectuosas así como las referencias y "N° de série" del mueble.

Consejos específicos : Litera

- a) **ADVERTENCIA** No se recomienda el uso de camas altas ni de la cama superior de las literas a niños menores de seis años debido al riesgo de lesiones por posibles caídas.
- b) **ADVERTENCIA** Si las camas altas y literas no se utilizan correctamente, pueden entrañar riesgos graves por lesiones de estrangulamiento. No atar ni colgar ningún elemento adicional a la litera si este no forma parte de la misma. Dichos elementos comprenden, entre otros, cuerdas, cordeles, cordones, ganchos, cinturones o bolsas.
- c) **ADVERTENCIA** Los niños pueden quedar atrapados entre la cama y una pared, una parte del techo (especialmente si es abuhardillado), muebles adyacentes (por ejemplo, armarios) u otros. Para prevenir daños graves, la distancia entre la barrera de seguridad y los elementos que se encuentren alrededor debe ser inferior a 75 mm o superior a 230 mm.
- d) **ADVERTENCIA** No utilizar la litera o la cama alta si una pieza de la estructura falta o sufre algún daño.
- f) REF. A06.606: utilizar un colchón con medidas 198 x 88 cm y un grosor máximo de 20 cm.
- g) La habitación debe ventilarse para mantener un nivel controlado de humedad e impedir la formación de moho en la cama o alrededor de la misma.
- j) Todas las camas altas y literas cuyo montaje no se realice por el fabricante o por personal autorizado deben incluir las instrucciones de ensamblaje con una lista de las piezas incluidas y herramientas necesarias.
- k) La cama cuenta con una marca que indica la altura máxima que debe alcanzar el colchón.
- j) Comprobar con regularidad que todos los elementos de sujeción estén correctamente fijados.

Handleiding voor montage en gebruik: Volg de gebruiksaanwijzingen nauwgezet op en respecteer de specifieke tips.

- Controleer voor montage of u alle onderdelen (inclusief beslag) goed ontvangen hebt en of ze in onberispelijke staat zijn.
- Gebruik enkel en alleen het geleverde of aangeraden montage gereedschap.
- De te monteren meubelen moeten door een volwassen persoon gemonteerd worden. Nooit door een kind!
- Jonge kinderen tijdens de montage op afstand houden (aanwezigheid van kleine onderdelen welke ingeslikt kunnen worden).
- Indien het meubel aan een muur of wand moet vastgehecht worden moet het juiste beslag voor die welbepaalde ondergrond gebruikt worden.
- Dit meubel zal u volledige tevredenheid geven onder normale gebruiksomstandigheden (Temperatuur van 15 tot 25°C / Vochtigheidsgraad van 50 tot 70%).
- Een slechte montage, plaatsing of verplaatsing kan het geheel of onderdelen ervan verzwakken.
- Controleer of het meubel geen defecten of functionele afwijking vertoont.
- Controleer of het meubel waterpas staat (aarzel niet om een pen (spie) te gebruiken om de goede werking en levensduur van deuren en laden te garanderen).
- Denk aan het milieu, sorteert de verpakkingen en breng ze naar een recycling verzamelpunt (containerpark).

Gebruiksaanwijzingen : - Een (vol)geladen meubel nooit verplaatsen.

- Vermijd obstakels op de vloer (ondergrond) bij het verplaatsen van een meubel op wielen en blokkeer de vergrendelbare wielen opnieuw na verplaatsing.
- Plaats geen zware of omvangrijke voorwerpen in een kinderkamer. Plaats voorwerpen op een ontoegankelijk oppervlak voor het kind (liefst in het midden van het meubel).
- Dit meubel zal u volledige tevredenheid geven onder normale gebruiksomstandigheden (Temperatuur van 15 tot 25°C / Vochtigheidsgraad van 50 tot 70%).
- **Belangrijk** : Bij elke wijziging en/of verschillende montage van het meubel, niet voorzien door de fabrikant, wordt de verantwoordelijkheid volledig verplaatst naar de persoon die de wijziging heeft toegebracht.
- **Waarschuwing** : Plaats het meubel nooit in de nabijheid van een open vlam, een open vuur of andere bronnen van hoge warmte, zoals elektrische vuren, gaskachels, enz.

Materiaal : - Al onze producten zijn vervaardigd uit vezelplaten op basis van hout klasse E1, volgens de EN 13986 norm, wat een formaldehyde gehalte van minder dan of gelijk aan 8 mg per 100g garandeert. De spaanplaten met een dikte van 16mm of meer gaan nog verder dan de eisen van de E1 classificatie engaranderen een formaldehyde gehalte van minder dan of gelijk aan 4 mg per 100 g.

- De vezelplaten zijn afgewerkt met fineer-papierdecor.

Onderhoud : - Het meubel uitsluitend reinigen met een zachte, licht met zeepwater doordrenkte doek en met een droge doek afdrogen.

- In geval een bed (ledikant) voorzien is van een vaste bodemplaat, regelmatig de matras keren om een betere ventilatie te verzekeren.

Garantie : - Als u, ondanks al onze controles, toch een anomalie vaststelt, vragen we u om contact op te nemen met uw distributeur, en de aard van het probleem te beschrijven. De distributeur zal u om het nummer van het defecte onderdeel of de nummers van de defecte onderdelen, en de referenties en het "N° de série" van uw meubel verzoeken.

Bijzondere adviezen: Hoogslaper

- a) **WAARSCHUWING** Hoogslapers en de bovenste bedden van stapelbedden zijn niet geschikt voor kinderen jonger dan zes jaar omwille van het risico van verwondingen doorvallen.
- b) **WAARSCHUWING** Als ze niet correct worden gebruikt, kunnen stapelbedden en hoogslapers een ernstig risico voor verwondingen door verstikking vormen. Bevestig of hang nooit elementen aan delen van het stapelbed die niet bestemd zijn voor gebruik met het betreffende bed. Deze elementen zijn onder meer snoeren, touwtjes, koorden, haken, riemen en tassen.
- c) **WAARSCHUWING** Kinderen kunnen bekneld raken tussen het bed en de muur, een deel van een hellend dak, het plafond, meubilair naast het bed (bijvoorbeeld kasten) of andere elementen. Om risico's van zware verwondingen te voorkomen, mag de afstand tussen de bovenste veiligheidsbalk en de elementen in de omgeving niet meer dan 75 mm bedragen of moet deze afstand groter zijn dan 230 mm.
- d) **WAARSCHUWING** Gebruik het stapelbed of de hoogslaper niet als een deel van de structuur ontbreekt of kapot is.
- f) REF. A06.606 : gebruik een matras van 198 x 88 x max. dikte 20 cm.
- g) De kamer moet worden geventileerd om een lage vochtigheidsgraad te behouden en schimmelvorming in en rond het bed te voorkomen.
- h) Alle stapelbedden en hoogslapers die door een andere persoon dan de fabrikant of diens vertegenwoordiger worden gemonteerd, moeten montage-instructies bevatten, inclusief een lijst met de geleverde stukken en informatie over het nodige gereedschap om het bed te monteren.
- j) Op het bed staat de maximumhoogte van het matras.
- k) Controleer regelmatig dat de bevestigingselementen goed zijn vastgemaakt.

DE WICHTIG - BITTE SORGFÄLTIG LESEN - ZUM AUFBEWAREN FÜR ANDERE MÖBEL

Anweisungen zur Installation-Montage und deren Verwendung : Bitte die Verwendungsbedingungen und fachlichen Hinweise beachten.

- Überprüfen Sie das Vorhandensein und Zustand der Beschläge und Teile vor der Montage.
- Verwenden Sie nur die bereitgestellten oder empfohlenen Teile.
- Die Montage der Möbel müssen von einem Erwachsenen und nicht von einem Kind ausgeführt werden.
- Halten Sie Kinder entfernt während der Installation-Montage (Vorhandensein von Kleinteilen, die verschluckt werden können).
- Wenn die Möbel an einem Trägerteil befestigt werden müssen, montieren Sie vorweg die vorgesehenen Beschläge dafür.
- Unsachgemäße Montage, Kalibrierung oder Handhabung kann Versprödung von Baugruppen und / oder Einzelteilen verursachen.
- Überprüfen Sie, dass das Möbel keine Mängel oder funktionelle Störungen aufweist.
- Überprüfen Sie, dass das Möbel eben montiert wird (zögern Sie nicht, Unterlegscheiben einzusetzen, um die ordnungsgemäße Funktion und Langlebigkeit der Türen und Schubladen zu gewährleisten).
- Um die Umwelt zu schützen, sortieren Sie die Verpackung und entsorgen sie diese in dem bestimmten und vorgesehenen Bereich für das Recycling (Abfall).

Anwendung : - Beladene Möbeln nicht bewegen-verschieben.

- Für ein Möbel mit Gleitrollen, unbedingt den Hindernissen welche sich auf dem Boden befinden ausweichen. Bewegen Sie das Möbel nur bei entriegelten Gleitrollen.
- Stellen Sie keine schweren oder sperrigen Gegenständen in das Zimmer eines Kindes. Gegenstände auf einem für Kinder nicht zugänglichen Ort lagern (vorzugsweise in der Mitte des Raumes).
- Dieses Möbel wird Ihnen vollsten Zufriedenheit unter normalen Einsatzbedingungen liefern (Temperatur: 15-25 ° C / Luftfeuchtigkeit: 50 bis 70%).
- **Wichtig :** Alle Änderungen welche an dem Möbel anlässlich der Montage anders und nicht wie vom Hersteller vorgegeben getätigt werden lehnen wir strikte ab. Für Montage-Veränderungen welche für das Produkt in und für seine ursprüngliche Nutzung vorgesehen sind übernimmt dann die alleinige Person die Verantwortung welche diese Transformation-Änderung vorgenommen- durchgeführt hat.
- **Warnung :** Vorsicht vor der Gefahr des Aufstellens der Möbel in der Nähe von offenen Flammen eines offenen Feuers oder anderen Quellen von starker Hitze, wie elektrischen Heizgeräten, Heizungen, Gas etc..

Materialien : - Alle unsere Produkte sind aus Holzwerkstoffen hergestellt und klassifiziert in E1 gemäß der Norm EN 13986, die eine Formaldehydgehalt von weniger als oder gleich 8 mg pro 100g garantiert. Zusätzlich ist dieses Produkt zum Teil in Spanplatten mit einem Durchmesser von größer oder gleich 16 mm realisiert, welche die Anforderungen für die Einstufung E1 übertreffen und somit einen Formaldehydgehalt von weniger als oder gleich 4 mg pro 100g garantieren.

- Die Spanplatten sind mit dekorativem Papier ummantelt.

Wartung : - Reinigen Sie die Möbel nur mit einem weichen Tuch und mit Seifenwasser, wischen Sie dieses mit einem trockenen Tuch nach.

- Im Fall von einem Bett mit einem Matratzen- Panel, drehen Sie die Matratze regelmäßig um eine optimale Belüftung zu gewährleisten.

Garantie : - Sollten Sie trotz unserer durchgeführten Kontrollen einen Mangel feststellen, melden Sie diesen bitte Ihrem Händler unter Angabe der Art des Mangels, der Nummer des bzw. der fehlerhaften Teile sowie der Referenzen und "**N° de série**" Ihres Möbels.

Besondere Hinweise: Etagenbetten und Hochbett

- WARNHINWEIS Hochbetten und das obere Bett von Etagenbetten sind aufgrund der Sturz- und damit verbundenen Verletzungsgefahr nicht für Kinder unter sechs Jahren geeignet.
- WARNHINWEIS Bei unsachmäßiger Benutzung können Etagen- und Hochbetten eine erhebliche Verletzungsgefahr durch Strangulierung darstellen. Bitte nie Elemente am Hochbett oder Teilen davon befestigen, die nicht für die Verwendung mit besagtem Bett vorgesehen sind. Solche Elemente betreffen unter anderem Seile, Kordeln, Schnüre, Bänder, Haken, Gürtel und Taschen.
- WARNHINWEIS Es besteht die Gefahr, dass Kinder zwischen dem Bett und einer Wand, einem Teil eines Schrägdachs, der Decke, angrenzenden Möbeln (z. B. Wandschränken) oder Ähnlichem eingeklemmt werden. Um der Gefahr schwerer Verletzungen vorzubeugen, muss der Sicherheitsabstand zwischen der oberen Sicherheitsstange und den angrenzenden Elementen weniger als 75 mm oder mehr als 230 mm betragen.
- WARNHINWEIS Das Etagen- oder Hochbett nie verwenden, wenn ein Teil der Struktur fehlt oder beschädigt ist.
- REF. A06.606 : Bitte eine Matratze von 198 x 88 cm und maximal 20 cm Dicke verwenden.
- Der Raum muss regelmäßig gelüftet werden, um den Feuchtegrad möglichst niedrig zu halten und Schimmelbildung im und rund um das Bett zu vermeiden.
- Alle Etagen- oder Hochbetten, die dazu bestimmt sind, von einer anderen Person als dem Hersteller oder seinem Vertreter aufgebaut zu werden, müssen eine Montageanleitung einschließlich der Liste des Lieferumfangs und der zum Aufbau benötigten Werkzeuge enthalten.
- Die zulässige maximale Matratzenhöhe ist durch eine Markierung am Bett gekennzeichnet.
- Bitte regelmäßig überprüfen, dass alle Befestigungselemente fest angezogen sind.

IT IMPORTANTE - LEGGERE ATTENTAMENTE - CONSERVARE PER IL FUTURO

Istruzioni per l'installazione e l'uso: Seguire attentamente le istruzioni per l'uso e rispettare i consigli specifici forniti.

- Verificare la presenza e lo stato delle componenti del mobile e delle parti prima del montaggio.
- Utilizzare solo gli elementi forniti o raccomandati.
- I mobili devono essere montati unicamente da un adulto e non da un bambino.
- Tenere i bambini lontano durante l'installazione-montaggio (presenza di piccole parti che possono essere ingerite).
- Quando il mobile deve essere fissato a un supporto, adattare la rispettiva ferramenta per il montaggio.
- Una non corretta installazione, la calibrazione o la manipolazione può causare la rottura del mobile.
- Controllare che i mobili non abbiano difetti o anomalie funzionali.
- Controllare che il mobile è in piano (non esitate a mettere degli spessori per assicurare il corretto funzionamento e la longevità di ante e cassetti).
- Per proteggere l'ambiente, smistamento degli imballaggi e deposito in una zona adibita al riciclaggio (dei rifiuti).

Istruzioni per l'uso : - Non spostare il mobile caricato.

- Per spostare un mobile con rotelle, evitare gli ostacoli sul pavimento, sbloccare le rotelle prima dello spostamento.
- Non appoggiare oggetti pesanti o ingombranti nella camera di un bambino. Appoggiare oggetti su una superficie non accessibile al bambino (preferibilmente al centro della camera).
- Questo mobile vi darà piena soddisfazione nelle normali condizioni di impiego (temperatura: 15-25 ° C / Umidità: 50 al 70%).
- **Importante :** Chi effettuerà eventuali modifiche non specificate dal produttore, con cambiamento dell' uso iniziale del mobile si assumerà la completa responsabilità per questa trasformazione.
- **Attenzione pericolo:** non piazzare i mobili in prossimità di fiamme o di un fuoco aperto o altre fonti di forte calore, come stufe elettriche, stufe a gas, ecc.

Materiali : - Tutti i nostri prodotti sono fatti di pannelli-truciolari di legno classificati E1 secondo la norma EN 13986, che garantisce un contenuto di formaldeide inferiore o uguale a 8 mg per 100 g. Inoltre, questo prodotto, con spessore maggiore o uguale a 16 mm oltre i requisiti della classificazione E1 garantisce un contenuto di formaldeide inferiore o uguale a 4 mg per 100g.

- I pannelli di truciolare sono rivestiti con carta decorativa.

Manutenzione : - Pulire il mobile solo con un panno morbido inumidito con acqua e sapone e asciugare con un panno asciutto.

- Nel caso di un letto con un pannello materasso, girare il materasso regolarmente per assicurare una migliore ventilazione.

Garanzia : - In caso venissero riscontrate anomalie nonostante tutti i nostri controlli, indicare al rivenditore la natura del difetto, il numero del pezzo o dei pezzi difettosi, le referenze e il "**N° de série**" del mobile.

Consiglio specifico: letti a castello, letti a soppalco

- AVVERTENZA** I letti a soppalco e i letti superiori dei letti a castello non sono adatti ai bambini di meno di sei anni poiché potrebbero farsi male a seguito di cadute.
- AVVERTENZA** Se non sono utilizzati correttamente, i letti a castello e i letti a soppalco possono essere fonte di grave pericolo dovuto a strangolamento. Non attaccare né appendere mai nessun elemento alle parti del letto a castello che non sia destinato a stare con il letto stesso. Questi elementi includono, ma non si limitano a: corde, spago, lacci, ganci, cinture e sacchetti.
- AVVERTENZA** I bambini possono ritrovarsi incastrati tra il letto e un muro, parte di un tetto inclinato, il soffitto, mobili adiacenti (per esempio, armadi) o altro. Per evitare il rischio di ferite gravi, la distanza tra la barriera di sicurezza superiore e gli elementi circostanti non deve superare i 75 mm o deve essere superiore a 230 mm. Non utilizzare il letto a castello o il letto a soppalco se manca un pezzo della struttura o se ci sono elementi danneggiati.
- RIF. A06.606: usare un materasso di dimensioni 198 x 88 con uno spessore massimo di 20 cm.
- È necessario areare la stanza per mantenere basso il livello di umidità ed evitare la proliferazione di muffe nel letto e intorno ad esso.
- Tutti i letti a castello e i letti a soppalco destinati ad essere montati da una persona diversa dal costruttore o dal suo rappresentante devono includere le istruzioni di montaggio, compreso un elenco dei pezzi forniti, specificando gli strumenti necessari per montare il letto.
- Un contrassegno sul letto indica l'altezza massima del materasso.
- Verificare regolarmente che tutti gli elementi di fissaggio siano attaccati correttamente.

Инструкции и гид по монтажированию : - Следуйте инструкциям по эксплуатации и соблюдайте приведенные рекомендации.

- Проследить о наличии всех элементов перед сборкой.
- Использовать только те инструменты который включены в сбор или которые указаны для сборки.
- Вся мебель должна быть собрана взрослым человеком, а не ребёнком.
- Держать в стороне всех маленьких детей, так как очень много маленьких деталей.
- Когда мебель должна быть смонтирована на что то, адаптировать материал к этой детали (шурупы, гвозди).
- Плохой сбор, монтирование или плохая работа может привести к повреждению мебели или её деталей.
- Проверить что мебель не выевляется плохой функциональности (двери, ящики).
- Проверить что мебель находится на одном уровне (не смонейтесь если нужно подоткнуть мебель для более долгого использования).
- Для сохранения окружающей среды, сортируйте весь мусор и выбросите его в преднозначенные места.

Советы по использованию : - Не передвигать мебель если в ней есть что то.

- Для тумбочек на колёсиках, осторожно если есть преграды при передвижении, а так же не блокируйте колёсике если вы его передвигаете.
- Не ставте слишком большую мебель в детскую комнату. Ставте все вещи вне зоне доступа вашего ребёнка.
- Эта мебель будет Вас радовать при обочном использовании и при обычной температуре.
- **Важно :** Вся мебель которая изменена не по советам инструкции, будет расчитана как мебель которая испульзуется по назначению. Все проблемы с этим связанные будут идти на ответственность человека который изменил мебель.
- **ОСТОРОЖНО :** Не ставте мебель близко к открытому огню или объектам возгорания (газовая плита, электро приборы).

Материалы :

- Вся наша продукция произведена из древесины под классом E1, по норме EN 13986, что гарантирует низкое содержание формальдегида (норма 8мл на 100гр). К тому же, все древесные плиты которые мы производим 16мм гарантируют содержание меньше нормы (4мг на 100 гр)
- Все плиты ДСП покрыты отделочным материалом. Все барьеры из цельного дерева и покрыты лаком.

Содержание : - Чистить мебель только мягкой тряпкой с мыльной водой, вытереть сухой тряпкой.

- В случае кровати со сплошной решеткой... переворачивать её регулярно для проветривания.

Гарантия : - Если, несмотря на все наши меры по контролю, вы находите неисправность, просим вас указать ее природу, номер неисправной(-ых) детали(-ей), а также артикулы и "**N° de série**" вашей единицы мебели у вашего дистрибьютора.

Спецефиные советы : Для высокой кровати

- ПРЕДУПРЕЖДЕНИЕ** Верхнеярусные кровати и верхние ярусы двухэтажных кроватей не предназначены для детей младше шести лет из-за риска повреждений в результате падения.
- ПРЕДУПРЕЖДЕНИЕ** При неправильном использовании двухэтажные и верхнеярусные кровати могут представлять опасность повреждений в результате удушения. Запрещается привязывать или подвешивать к частям двухэтажной кровати элементы, не предназначенные для использования с двухэтажной кроватью. К таким элементам относятся веревки, бечевки, шнуры, крючки, ремни, мешки и т. п.
- ПРЕДУПРЕЖДЕНИЕ** Дети могут застрять между кроватью и стеной, частью наклонной крыши, потолком, рядом стоящей мебелью (например, стенным шкафом) или другими объектами. Во избежание риска повреждений расстояние между верхним защитным барьером и окружающими объектами не должно превышать 75 мм или должно составлять более 230 мм.
- ПРЕДУПРЕЖДЕНИЕ** Не используйте двухэтажную или верхнеярусную кровать, если какая-либо часть конструкции отсутствует или повреждена.
- № A06.606: используйте матрас размером 198 x 88 см и толщиной не более 20 см.
- Необходимо проветривать комнату для поддержания невысокого уровня влажности и предотвращения появления плесени на кровати и около нее.
- Ко всем двухэтажным или верхнеярусным кроватям, сборку которых будет производить не сам производитель или его представитель, должна прилагаться инструкция по сборке, включающая список поставляемых деталей и необходимых инструментов.
- Маркировка на кровати показывает максимальную высоту матраса.
- Регулярно убеждайтесь, что фиксирующие элементы надежно закреплены.

Instruções de montagem e utilização: - Siga as instruções de utilização e respeite os conselhos específicos contidos neste manual.

- Verifique a existência e o estado das ferragens e das peças antes da montagem.
- Utilize apenas as ferramentas fornecidas ou indicadas.
- os móveis devem ser montados por um adulto e nunca por uma criança.
- Afaste as crianças durante a montagem (há pequenas peças que podem ser engolidas)..
- Quando o móvel deva ser fixado a um suporte, adapte as ferragens a esse suporte.
- Uma deficiente montagem, regulação ou manutenção pode fragilizar as uniões e/ou as peças.
- Verifique que o móvel não apresenta nenhum defeito ou anomalia funcional,
- Verifique que o móvel está nivelado (se necessário coloque calços para garantir o bom funcionamento e longevidade das portas e gavetas),
- para proteger o ambiente, coloque as embalagens no respetivo contentor de reciclagem (lixo).

Conselhos de utilização : - Não desloque um móvel carregado.

- Para um móvel com rodas, aquando da deslocação, evite os obstáculos no chão e bloqueie as rodas antes da utilização.
- Não coloque objetos pesados ou volumosos no quarto de uma criança. Coloque os objetos sobre uma superfície não acessível à criança (preferencialmente no centro do móvel).
- Este móvel vai satisfazer as suas expectativas nas condições normais de utilização (temperatura de 15 a 25° / humidade de 50 a 70%).
- **IMPORTANTE:** - Qualquer modificação feita no móvel ou montagem diferente, não prevista pelo fabricante, altera a classificação da utilização inicial do produto e responsabiliza quem tenha procedido a essa transformação.
- **Aviso:** Atenção ao perigo de colocar o móvel na proximidade de chamas, de uma lareira ou outras fontes de calor intenso, como aquecedores elétricos ou a gás, etc.;

Materiais :

- Todos os nossos produtos são fabricados com painéis à base de madeira classe E1, de acordo com a norma EN 13986, o que garante um valor de formaldeído inferior ou igual a 8 mg por 100g. Para além disso, para este produto, os painéis de partículas com espessura superior a 16 mm vão para além das exigências da classificação E1 e garantem um valor de formaldeído inferior ou igual a 4 mg por 100g
- Os painéis de partículas são revestidos com papel decorativo.

Manutenção : - Limpe o móvel apenas com um pano suave embebido em água e sabão e de seguida enxague com um pano seco,

- No caso de uma cama com base para o colchão, para assegurar uma melhor ventilação, é aconselhável virar o lado do colchão regularmente

Garantia : - Se, apesar de todos os nossos controlos, detetar uma anomalia, pedimos que a pormenorize, indique o número da peça ou peças defeituosas bem como as referências e "**N° de série**" do seu móvel junto do seu distribuidor.

Conselhos específicos: Cama Alta

- AVISO** As camas sobreelevadas e a cama de cima dos beliches não são adequadas para crianças com menos de 6 anos devido ao risco de ferimentos por quedas
- AVISO** Se não forem utilizados corretamente, os beliches e as camas sobreelevadas podem apresentar um sério risco de ferimentos por estrangulamento. Nunca prenda ou suspenda elementos às partes da cama superior que não se destinem a estar nessa cama. Estes elementos incluem, mas não só, cordas, cordões, ganchos, cintos e bolsas.
- AVISO** As crianças podem ficar entaladas entre a cama e a parede, uma parte de um telhado inclinado, teto, móveis próximos (por exemplo armários) ou outros. Para evitar todo o tipo de ferimentos graves, a distância entre a grade de segurança e os elementos envolventes não deve ultrapassar os 75 mm ou deve ser superior a 230 mm.
- AVISO** Não utilize um beliche ou uma cama sobreelevada se alguma peça da estrutura estiver partida ou em falta.
- REF. A06.606: utilize um colchão de dimensão 198 x 88 cm e espessura máxima de 20 cm.
- É necessário ventilar a divisão para manter um nível pouco elevado de humidade e impedir o desenvolvimento de bolor na cama e na envolvente.
- Todos os beliches ou camas sobreelevadas destinadas a ser montadas por outras pessoas que não o fabricante ou um seu representante devem conter instruções de montagem que incluam uma lista das peças fornecidas e pormenorizar as ferramentas necessárias para a montagem.
- Uma marcação na cama indica a altura máxima do colchão.
- Verifique regularmente que todos os elementos de fixação estão devidamente apertados.

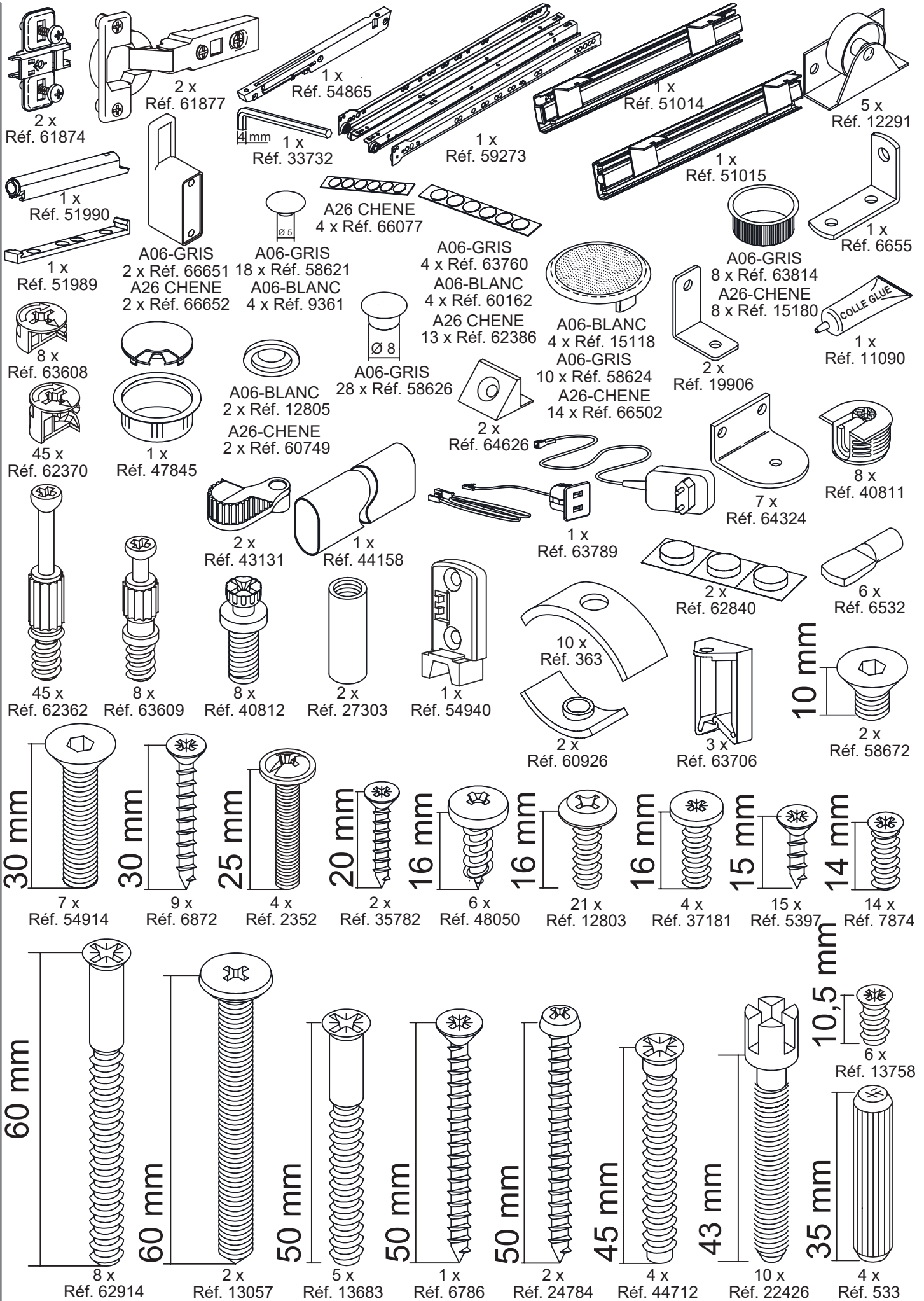

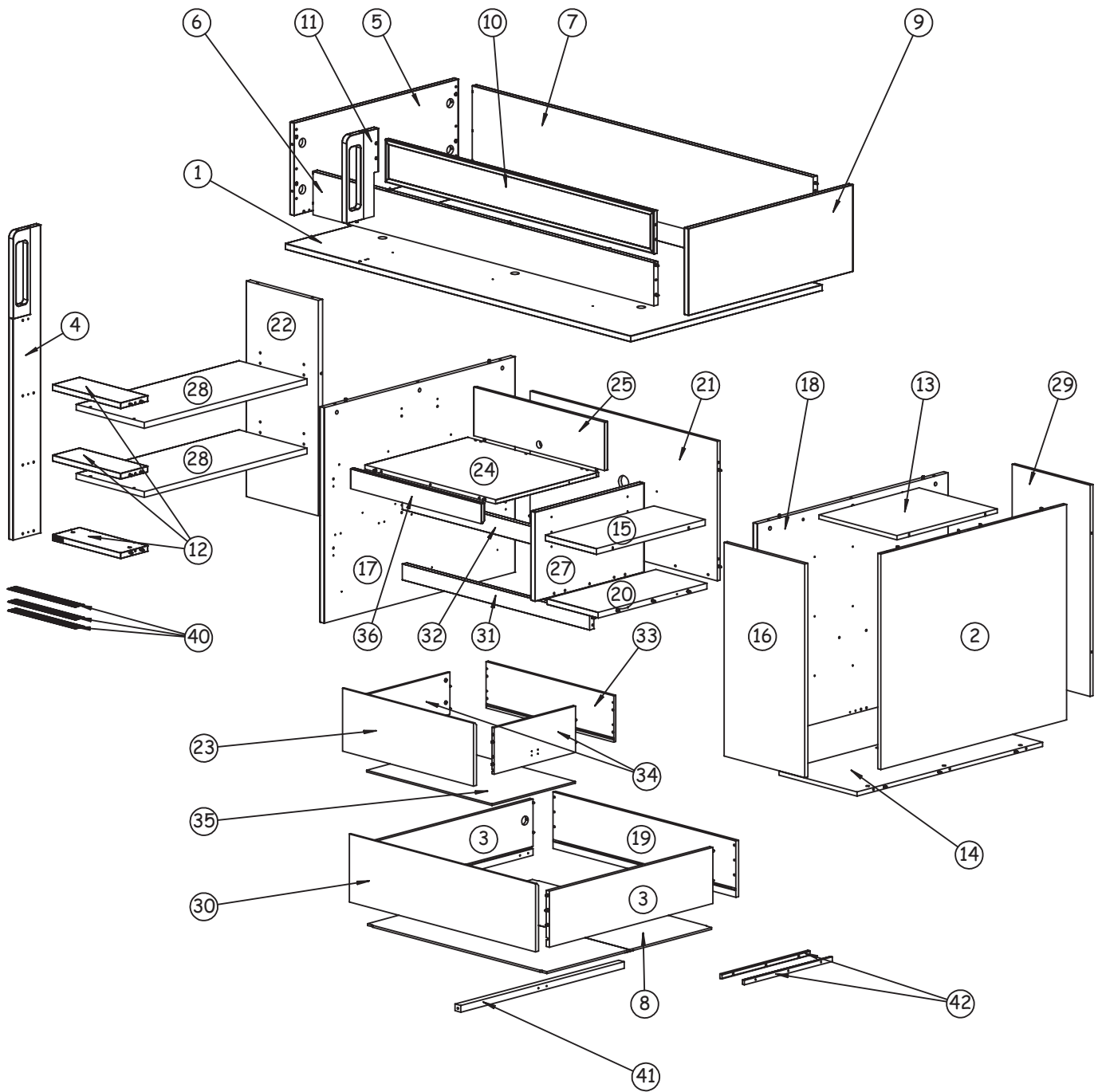

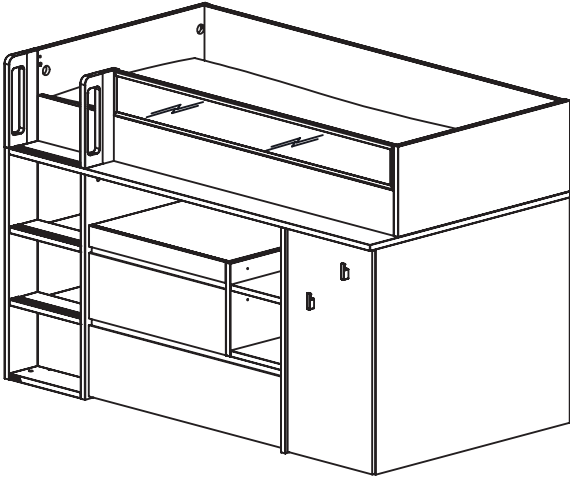
A

➔ P8 → P45

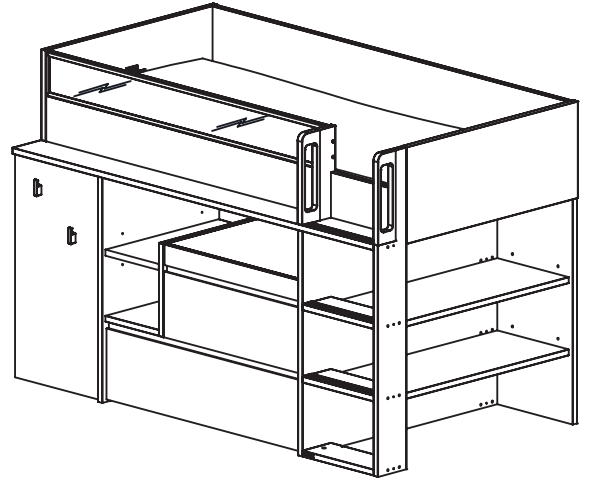
B

➔ P46 → P83

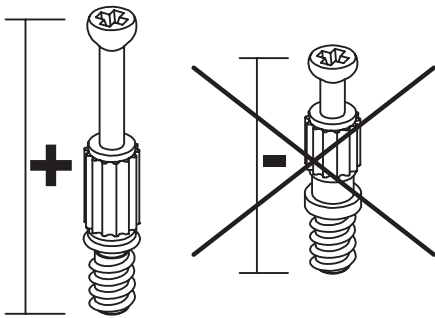

3 x
Réf. 62363

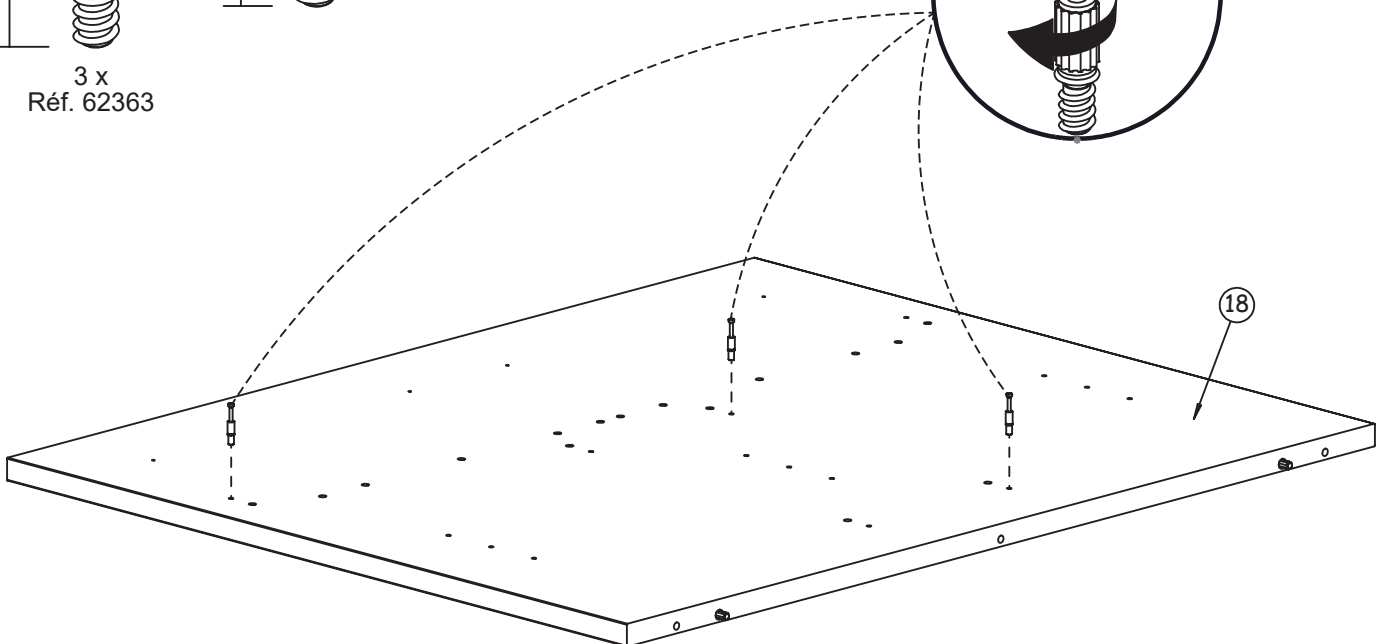
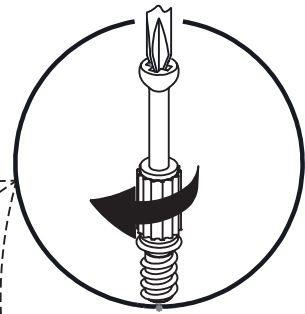
**A-1**

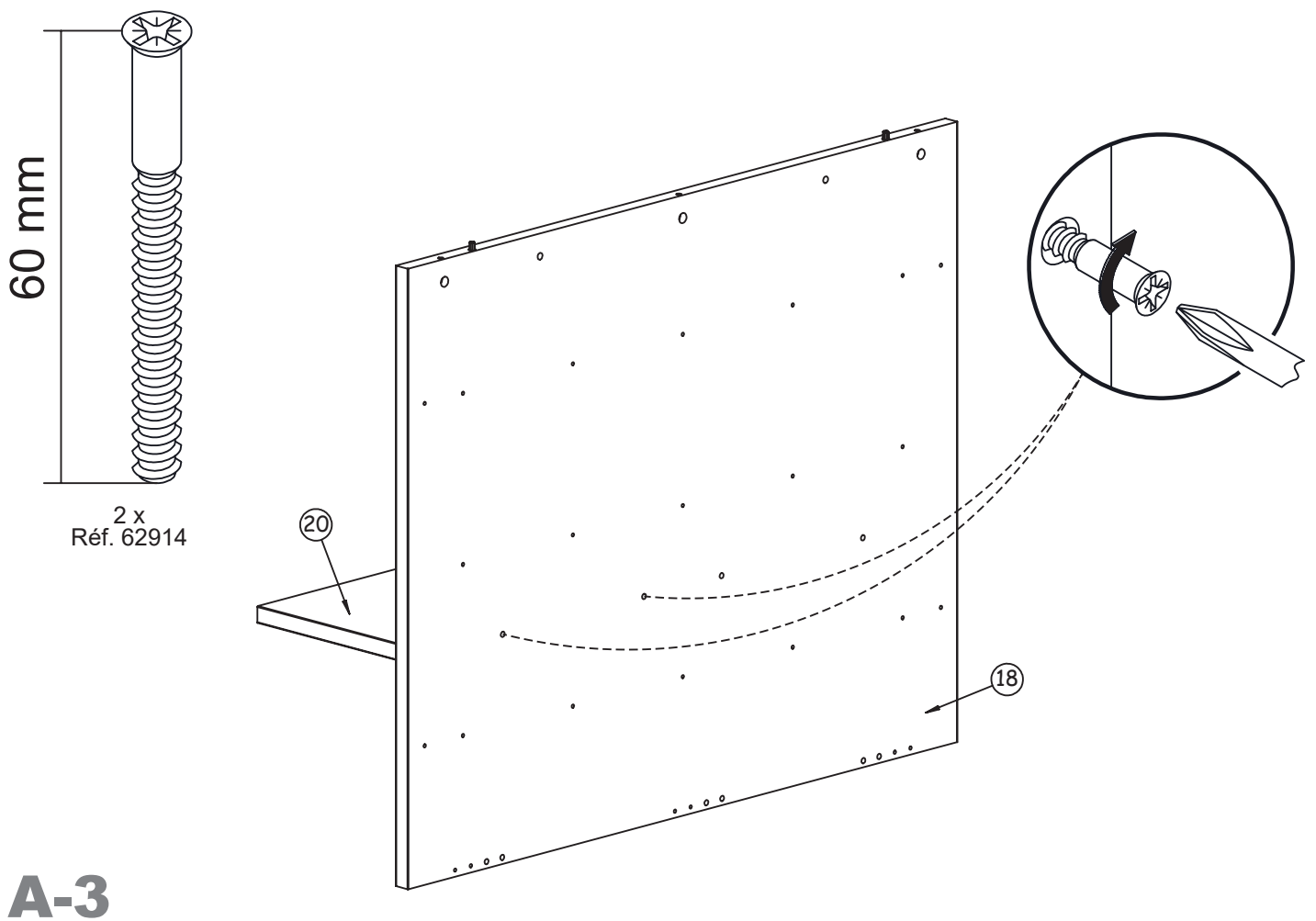
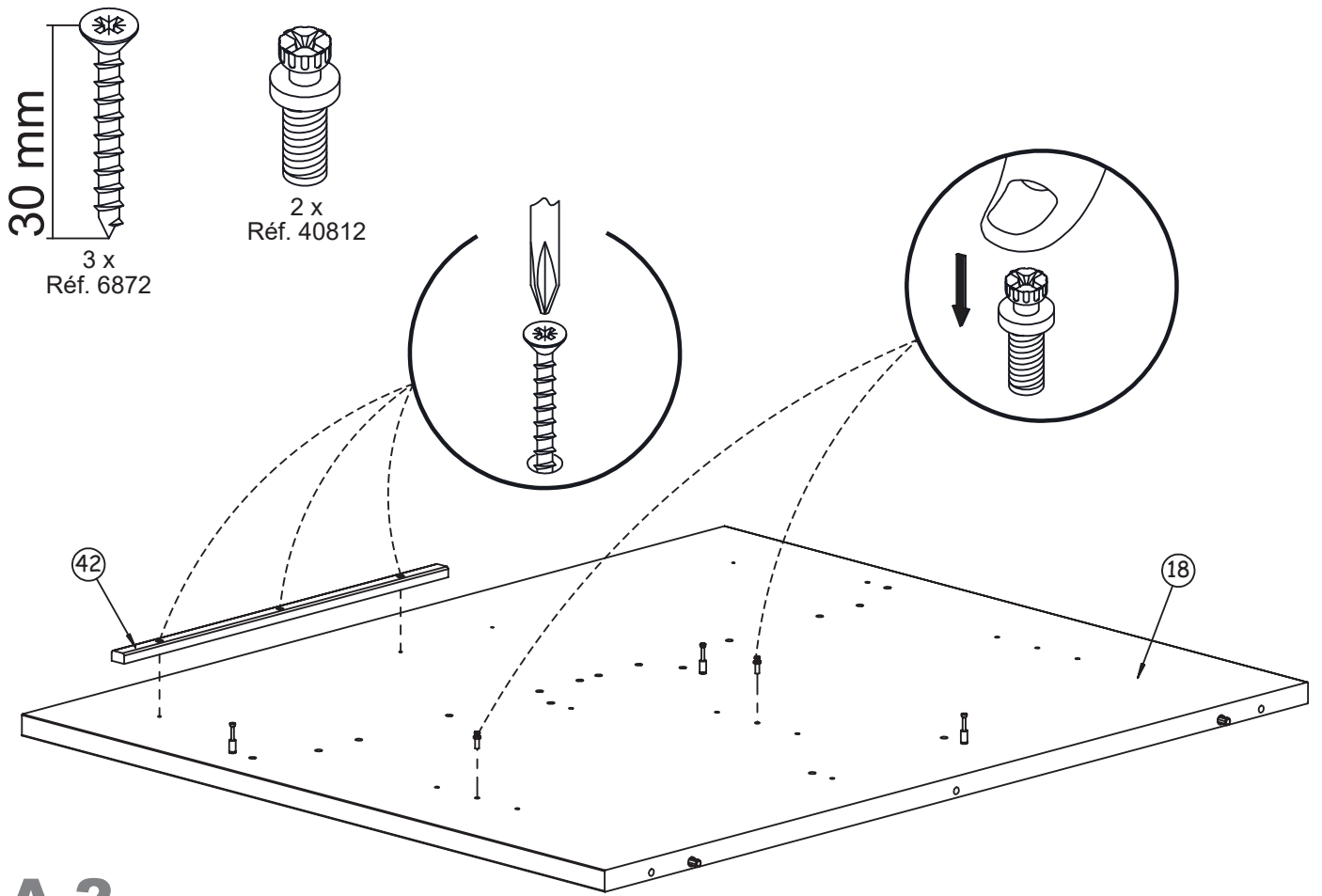

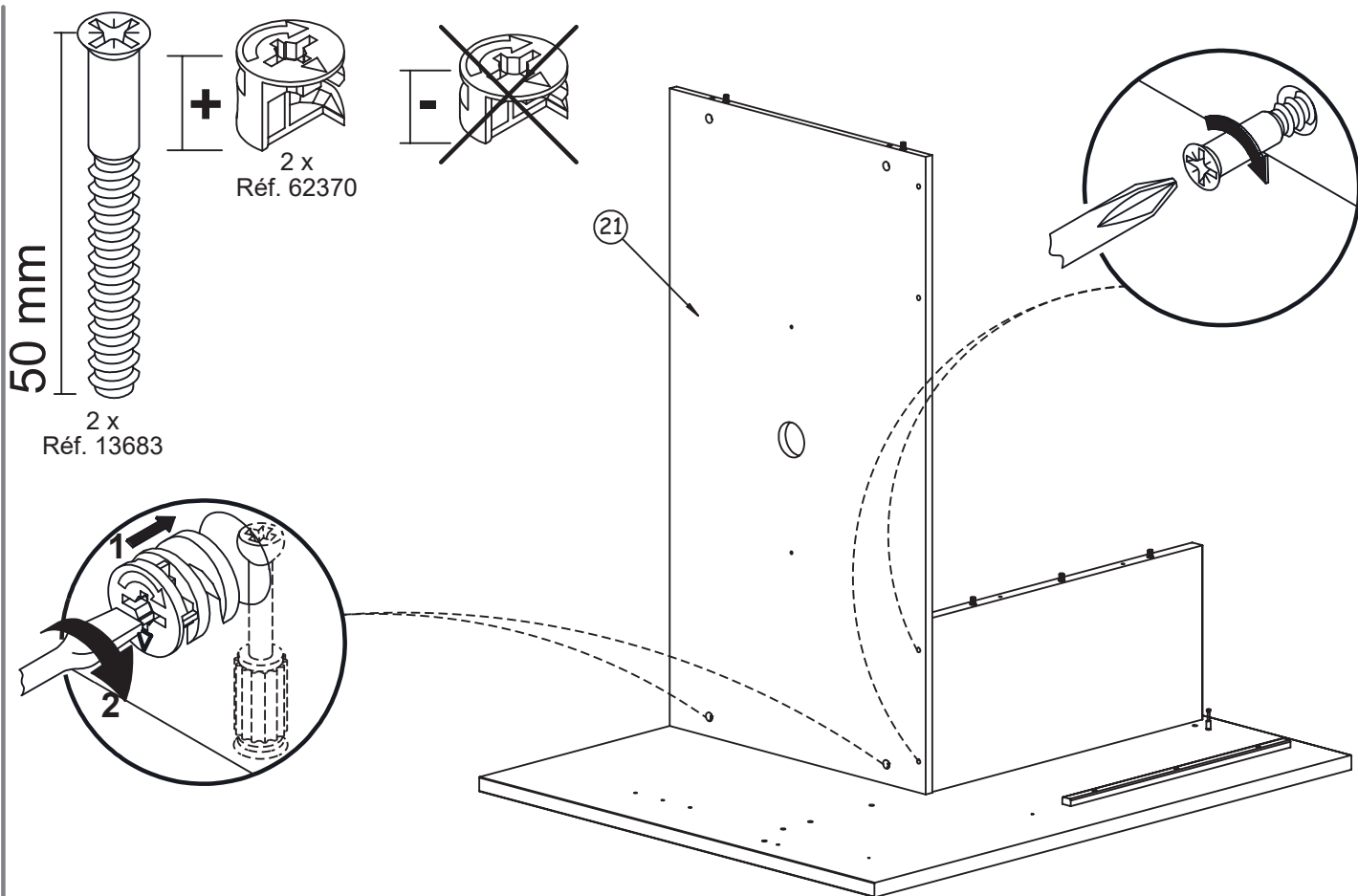

A-4

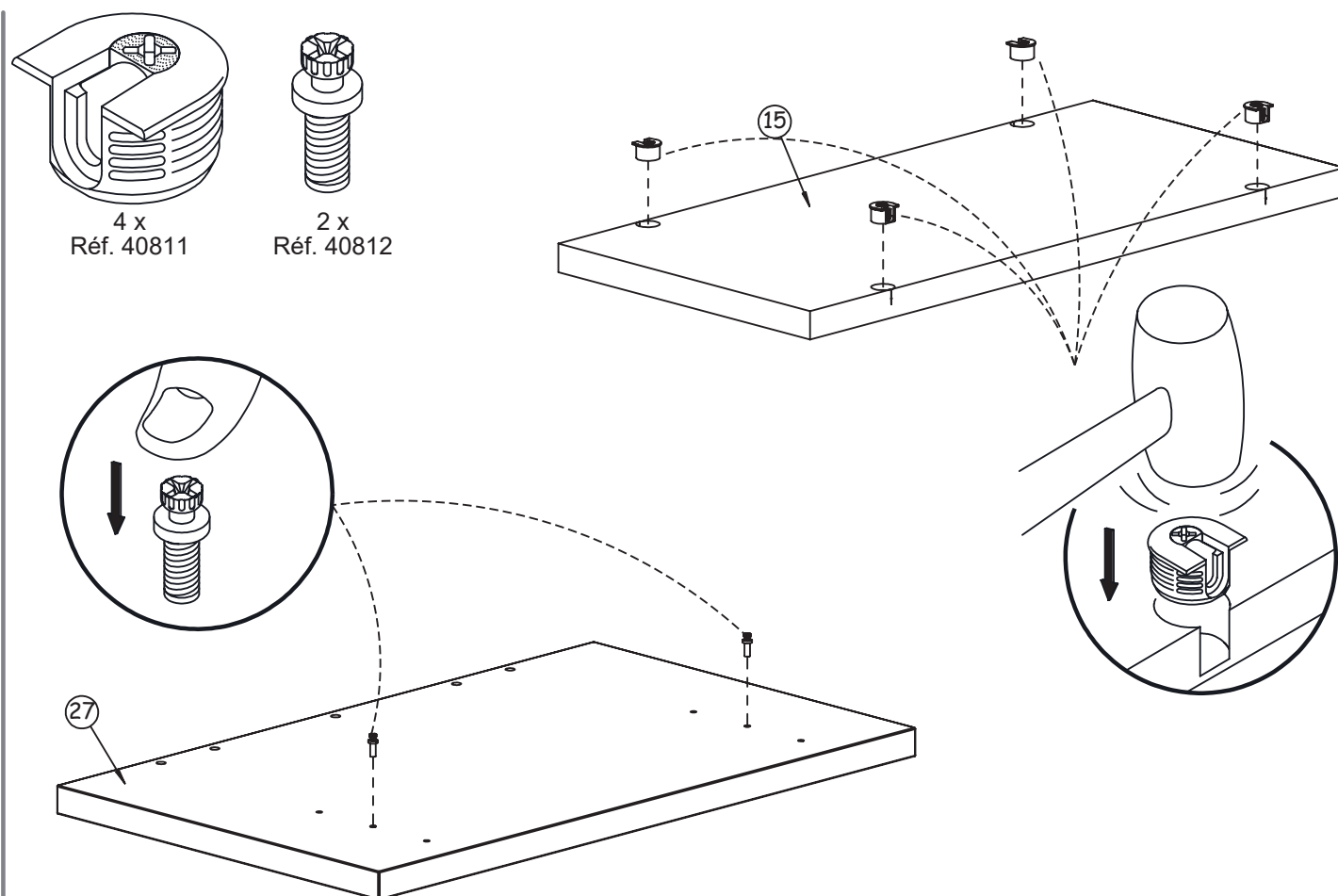

A-5

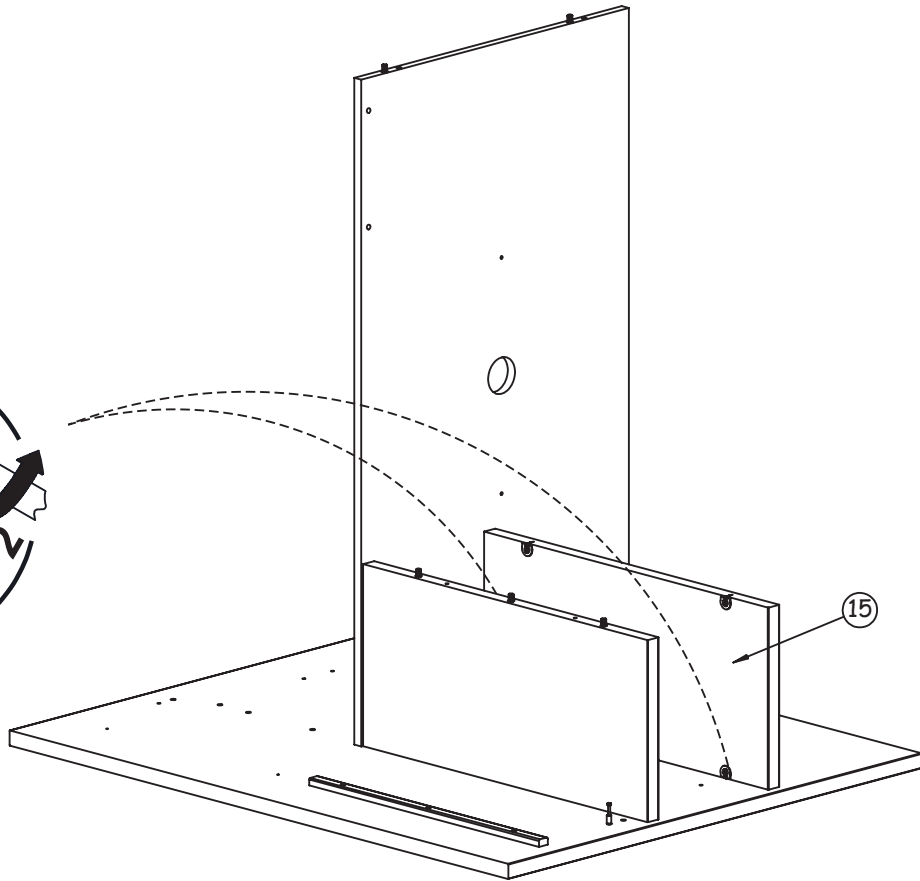
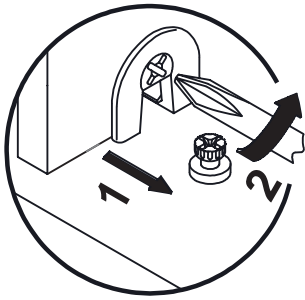

A-6

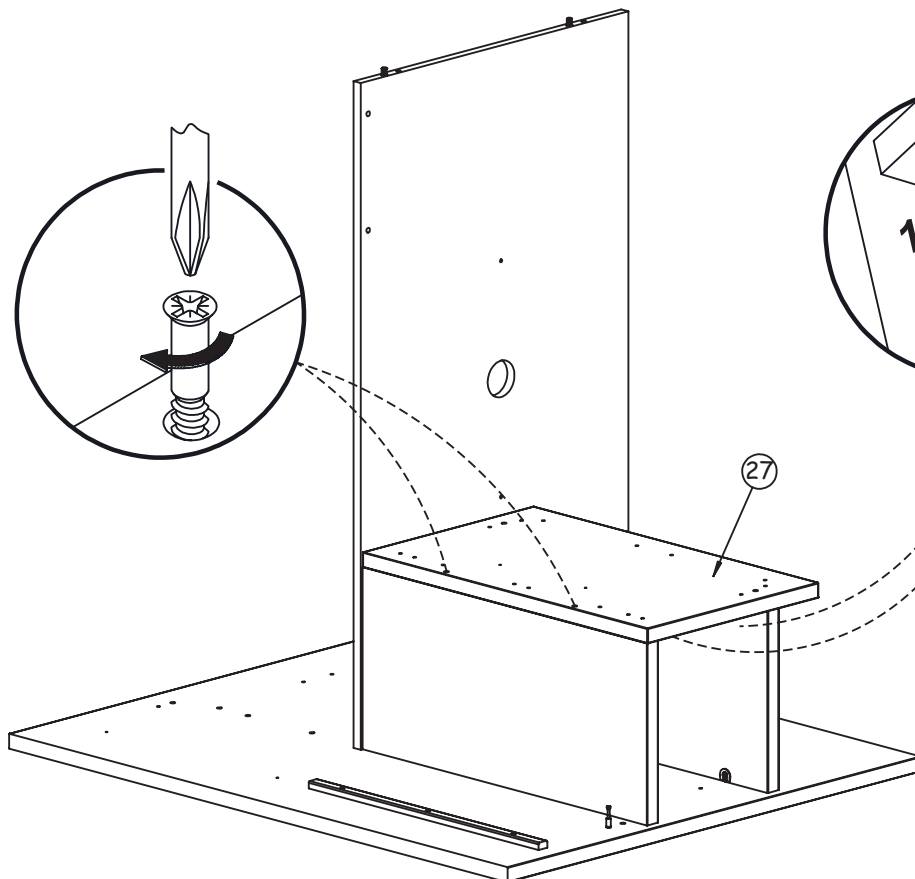
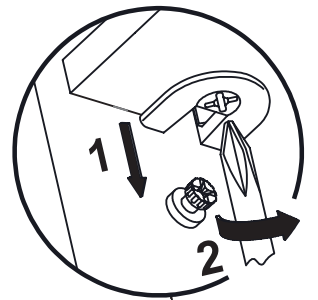
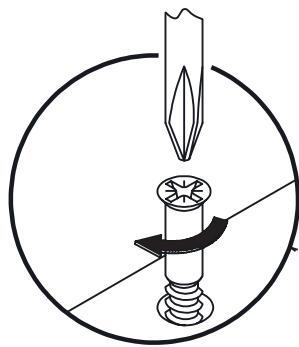
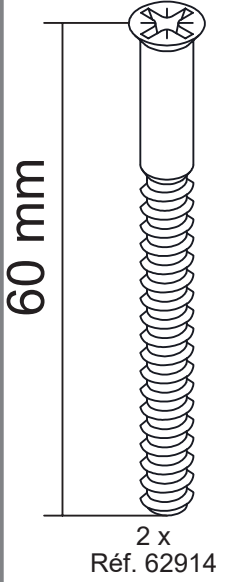

A-7

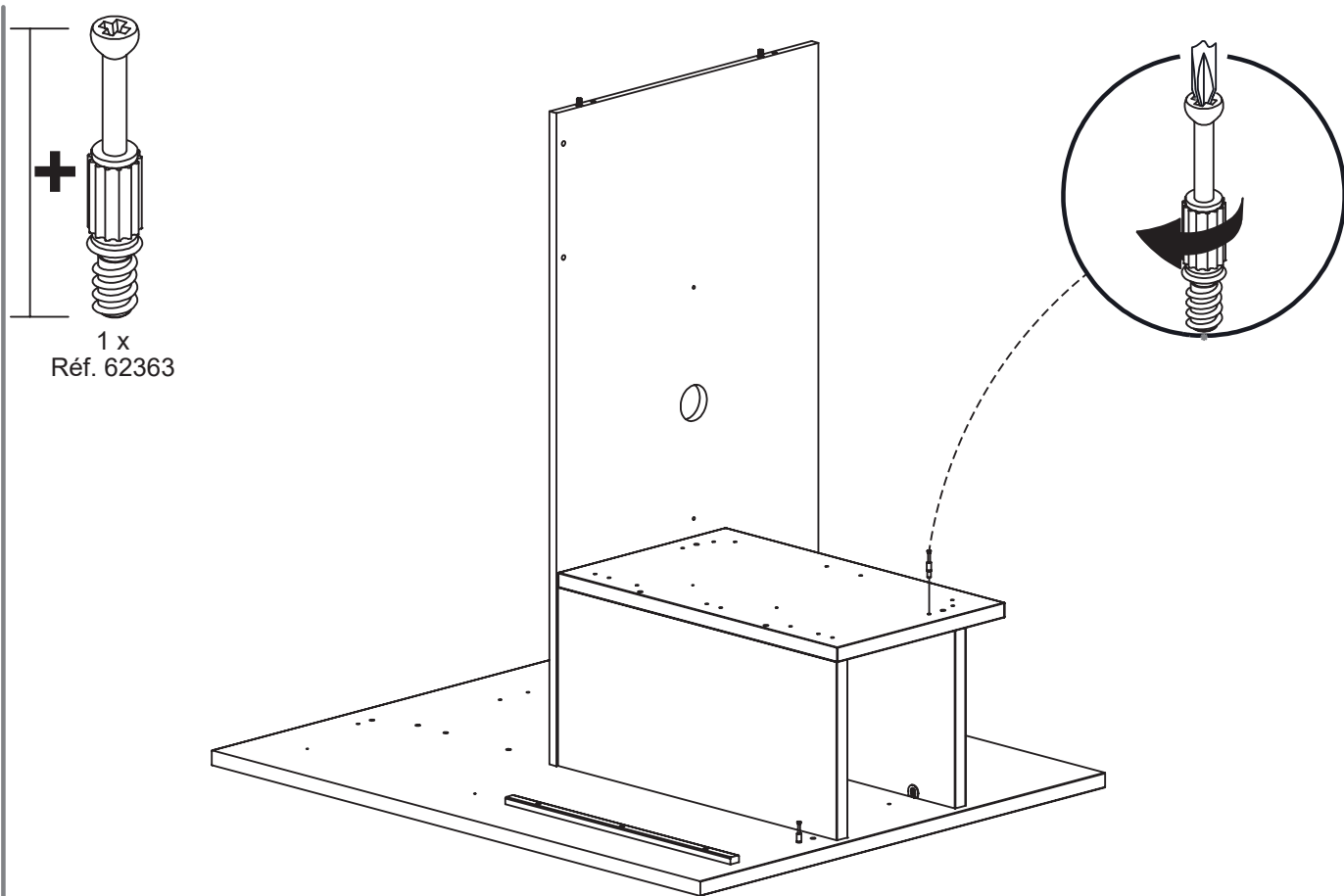

A-8

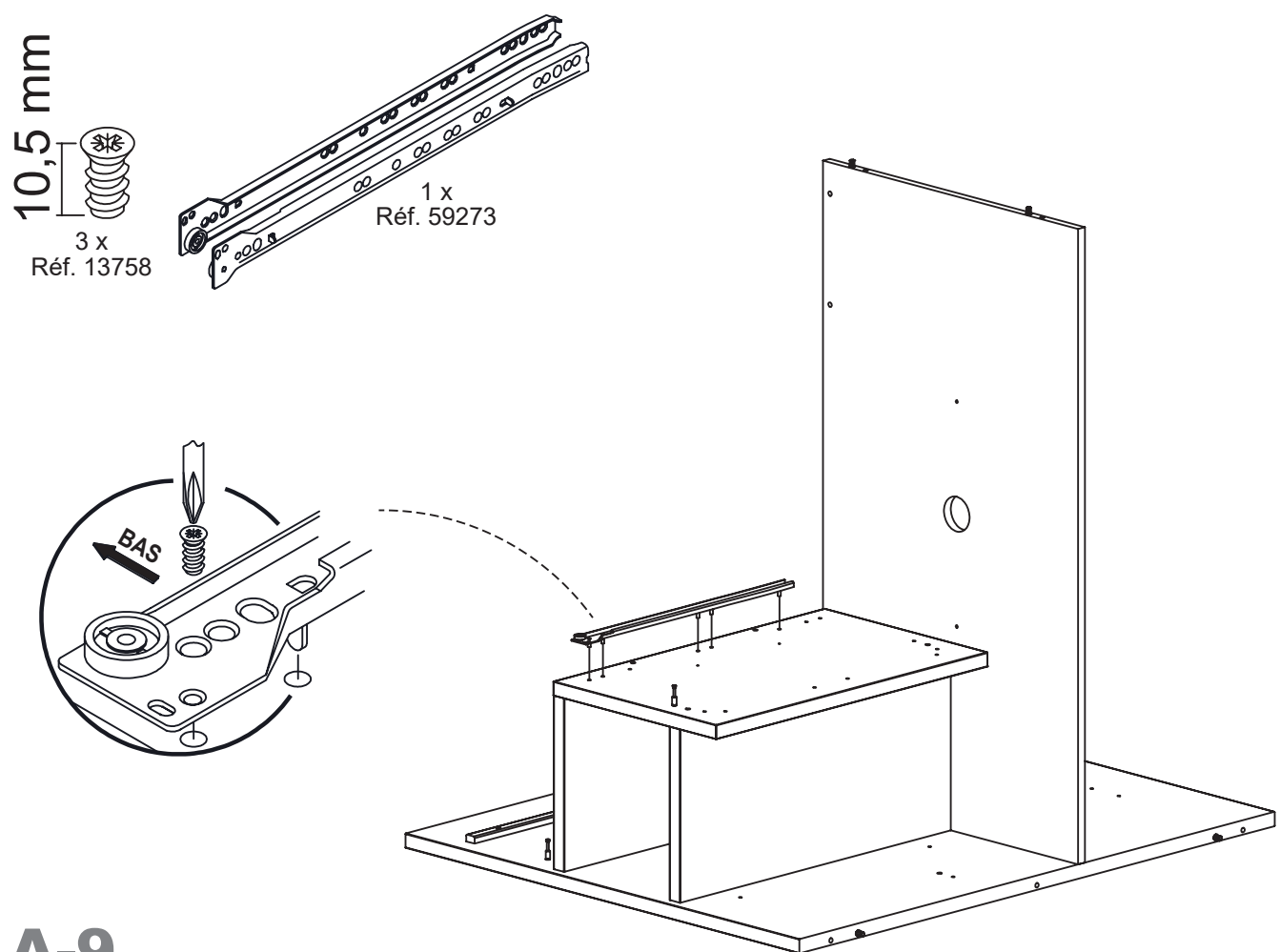

A-9

16 mm
2 x
Réf. 37181

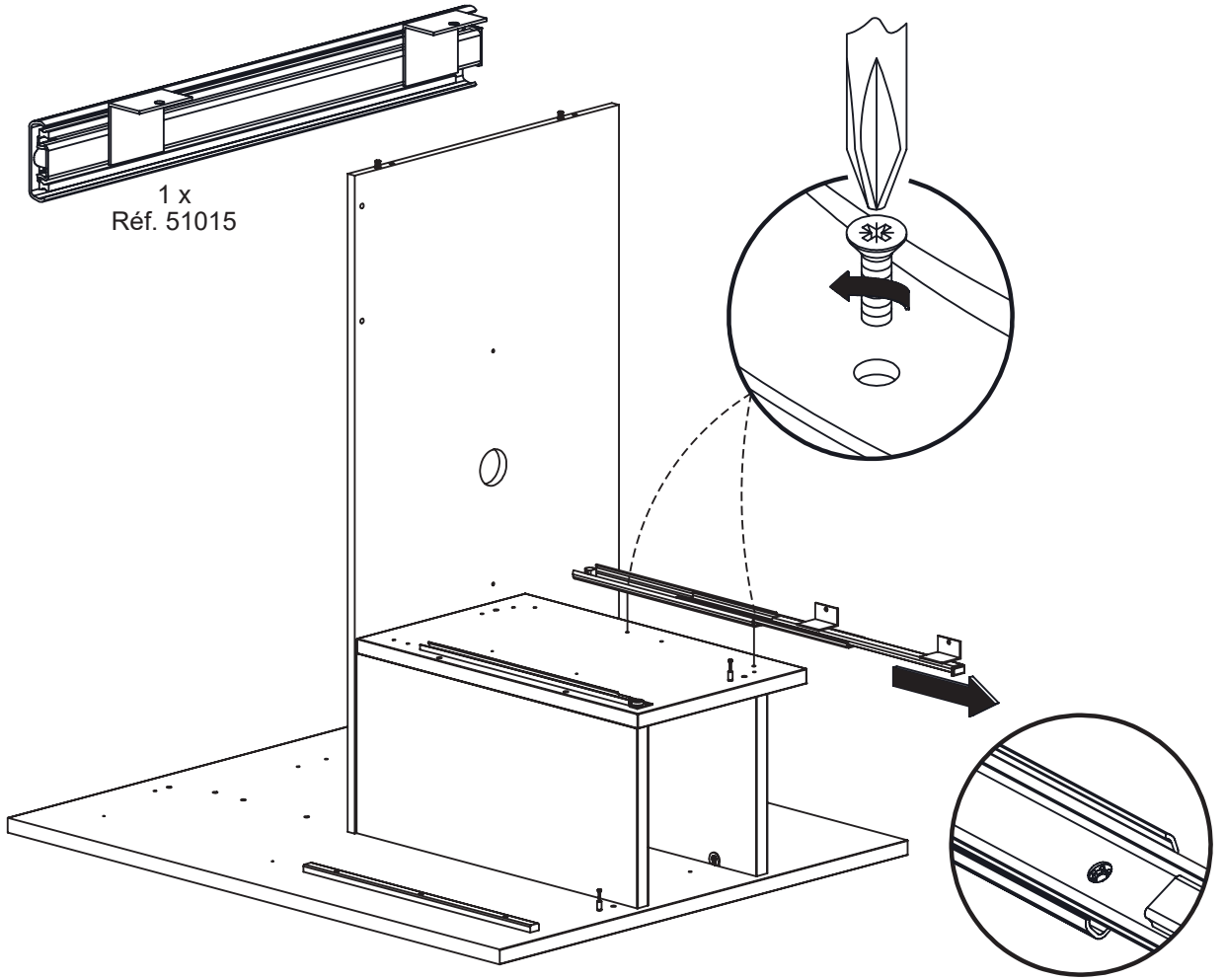

16 mm
2 x
Réf. 12803

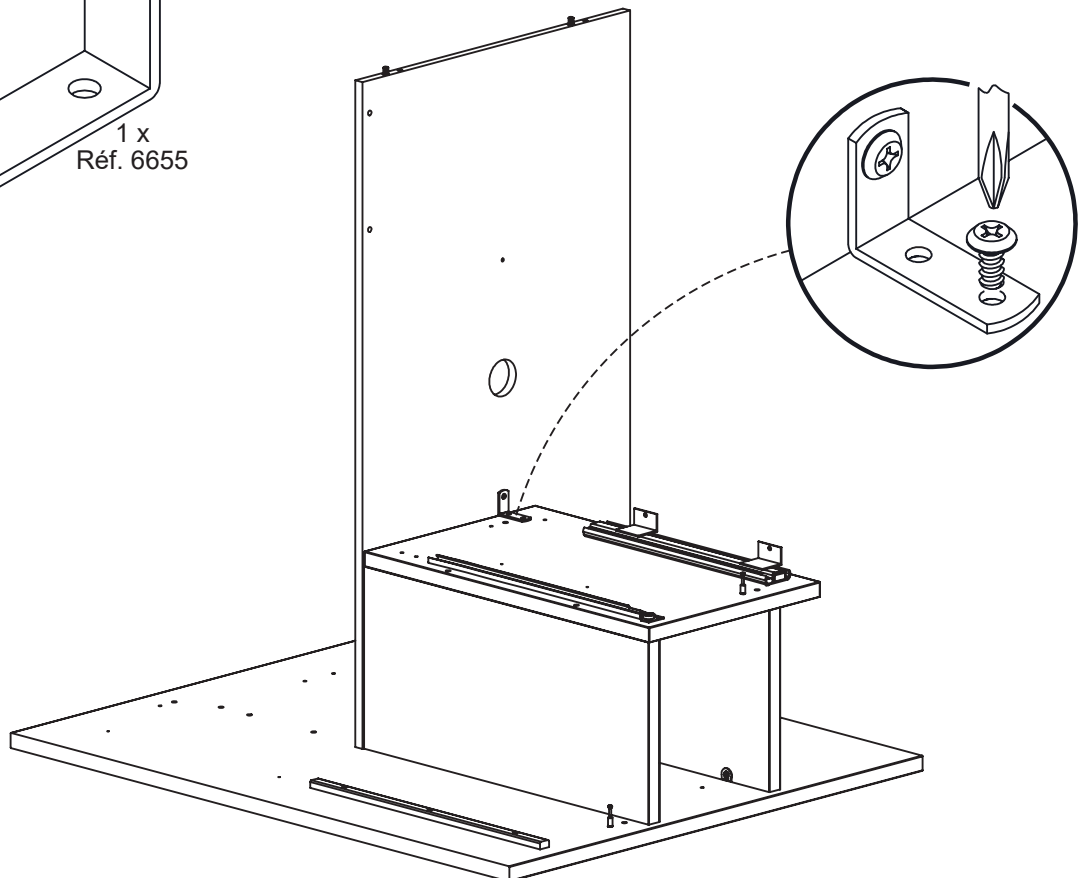
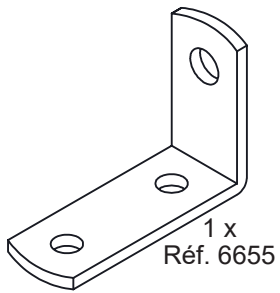

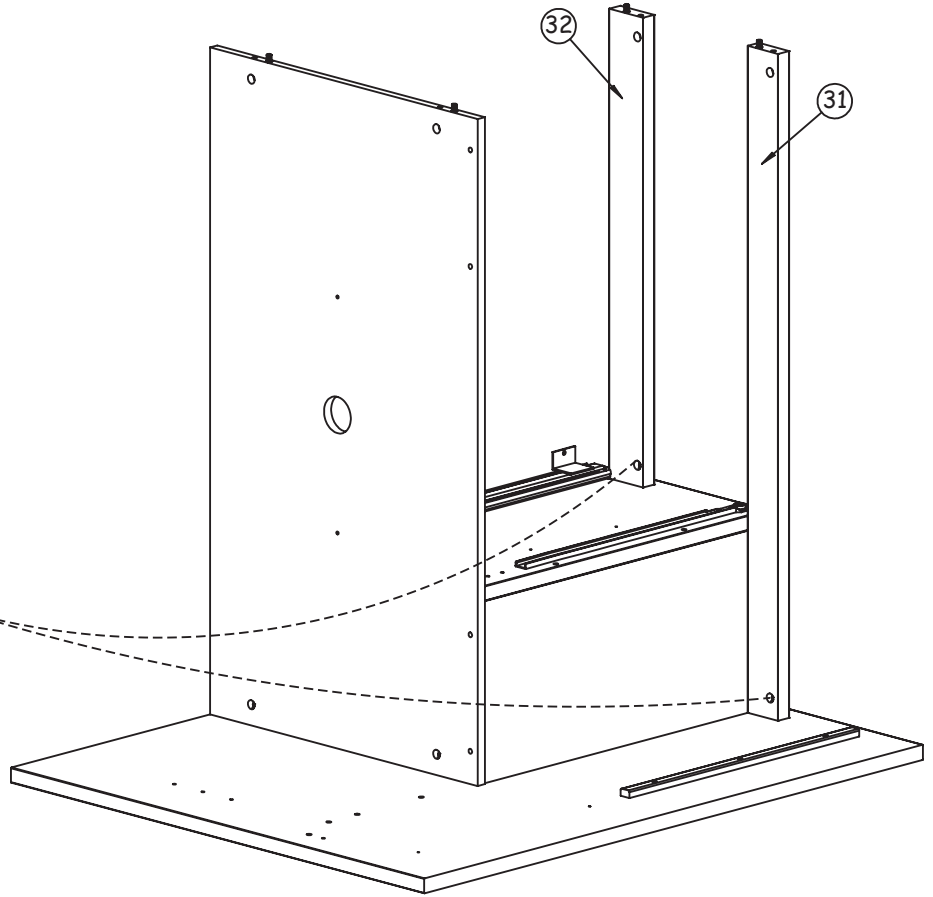
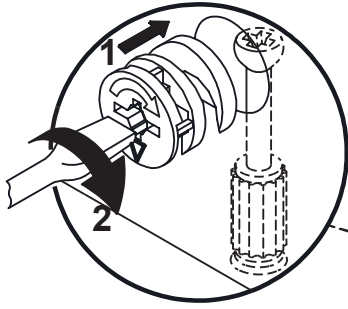
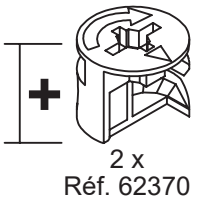

A-12

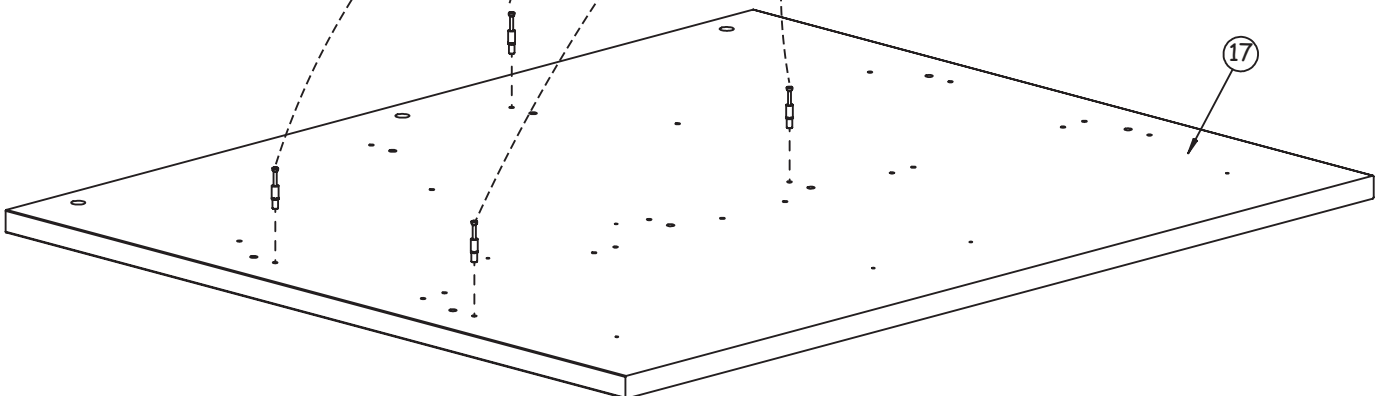
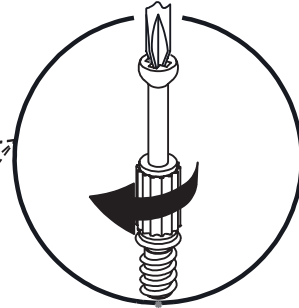
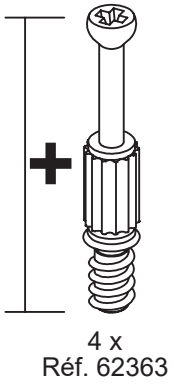

A-13

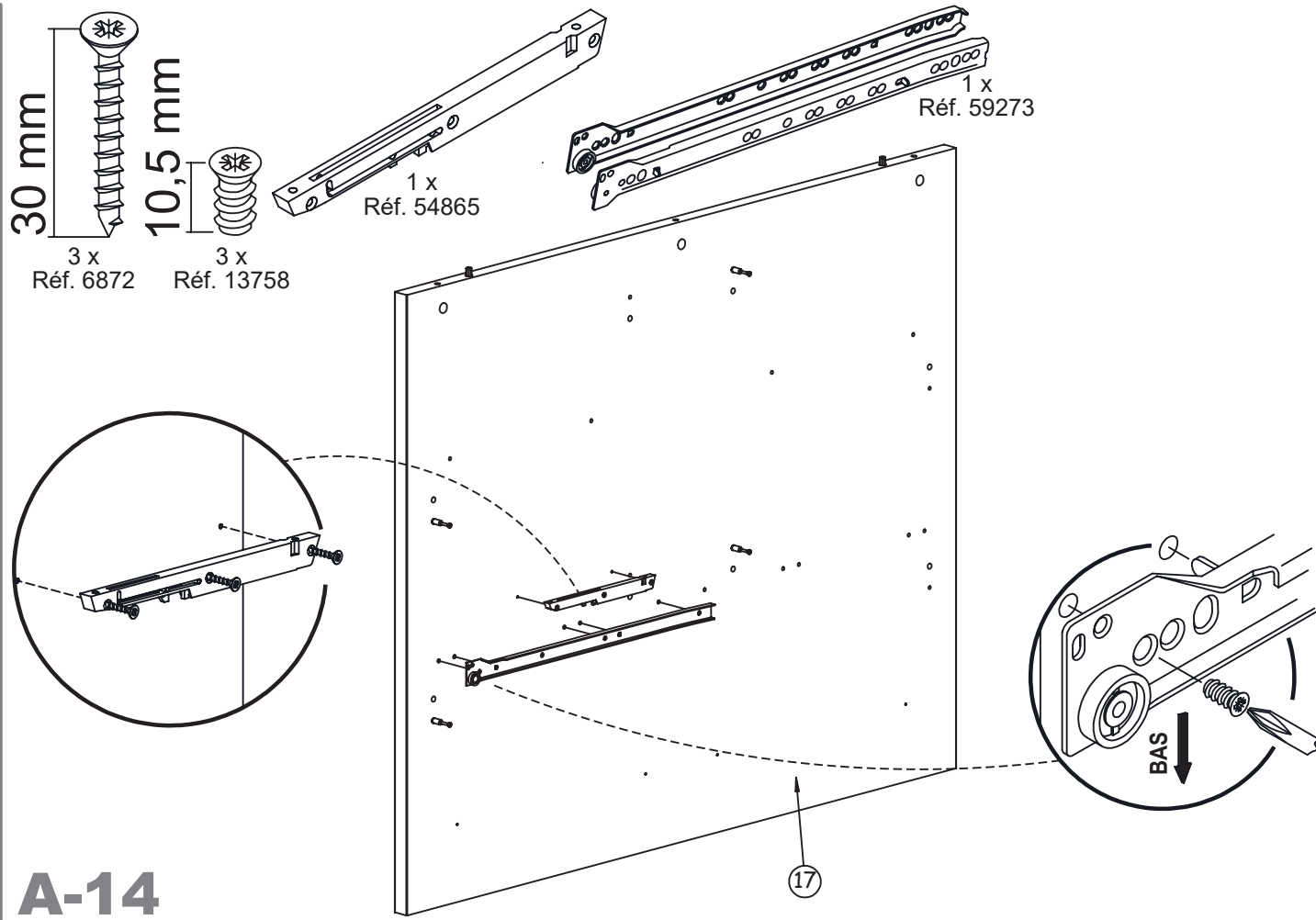

A-14

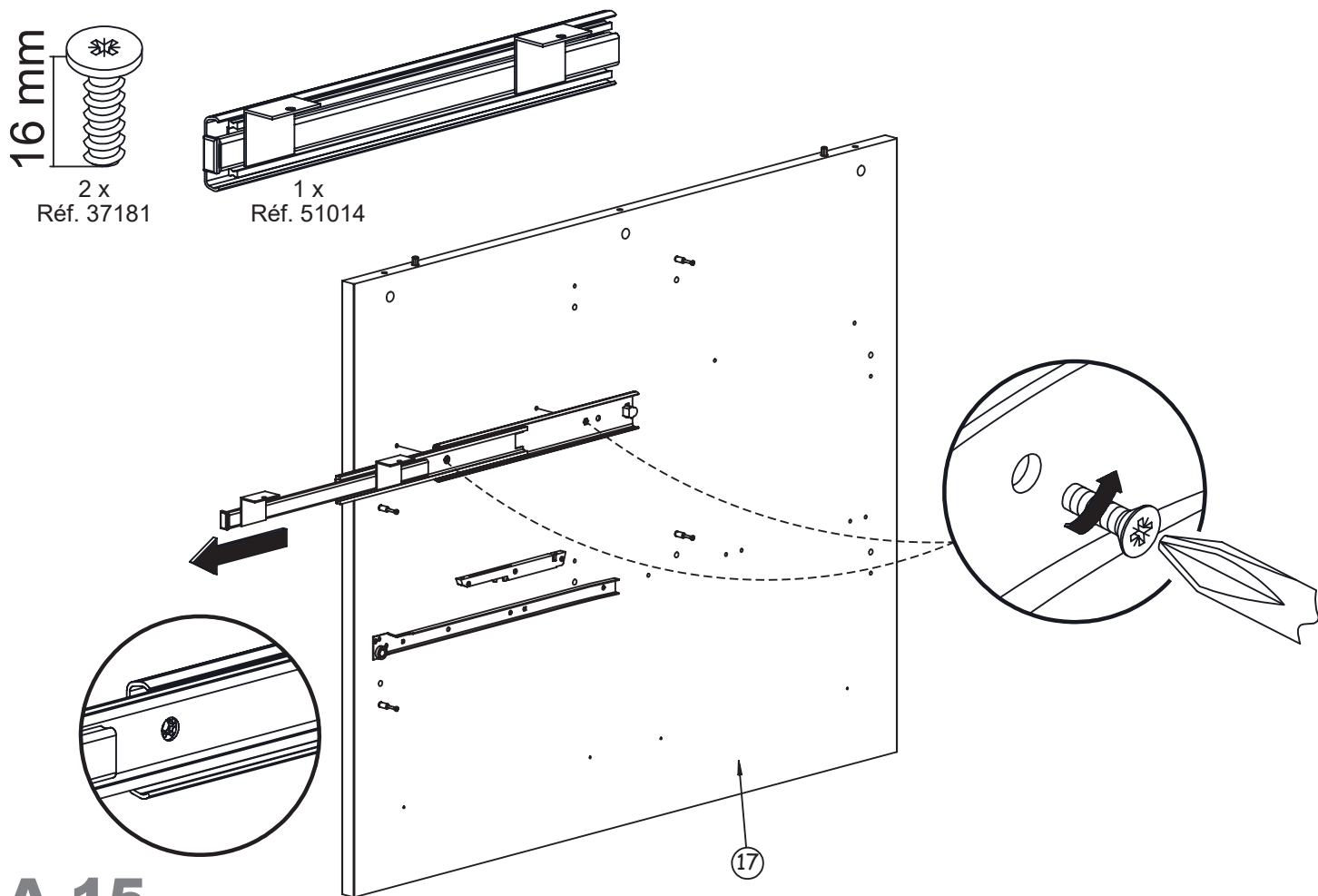

A-15

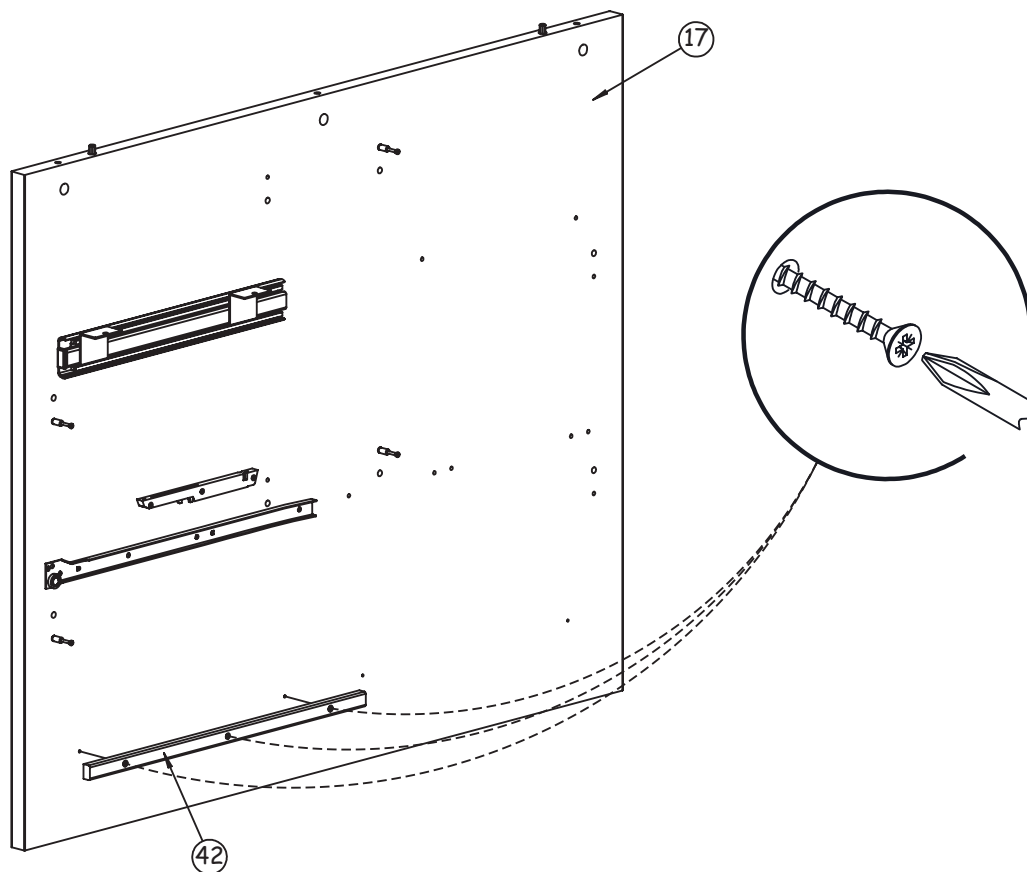
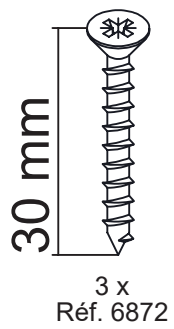

A-16

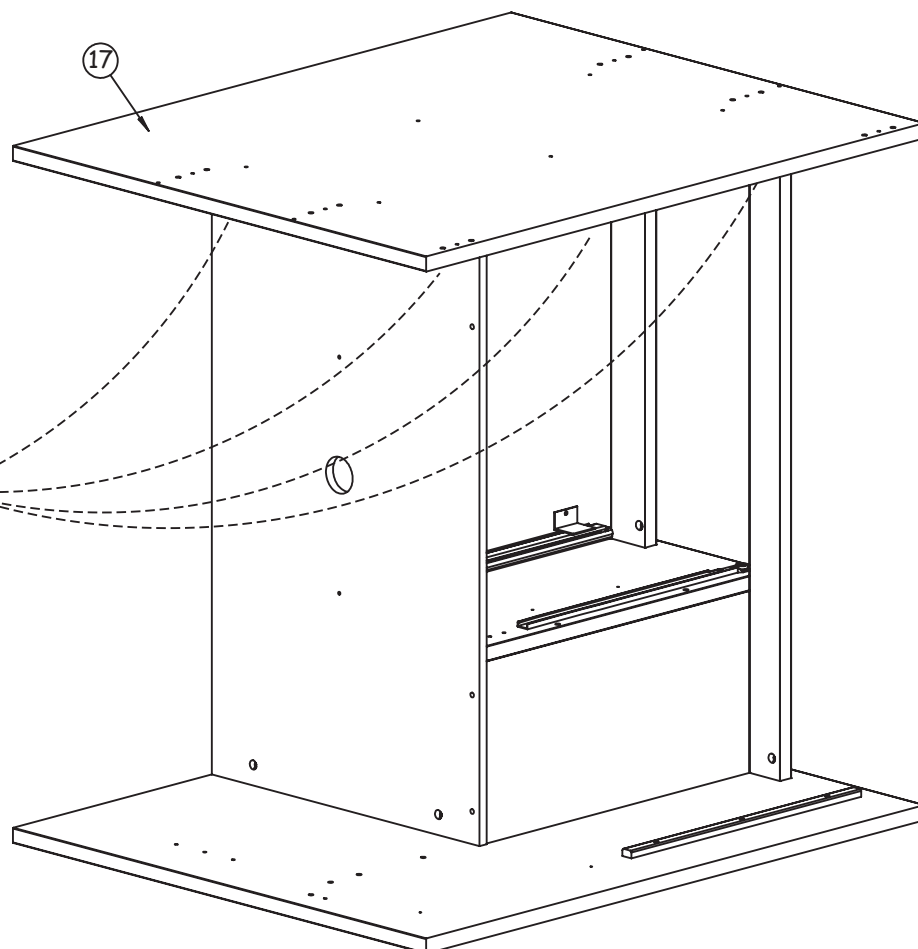
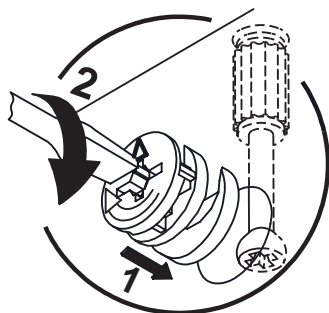
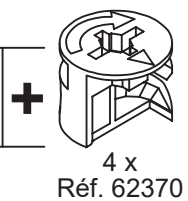

A-17

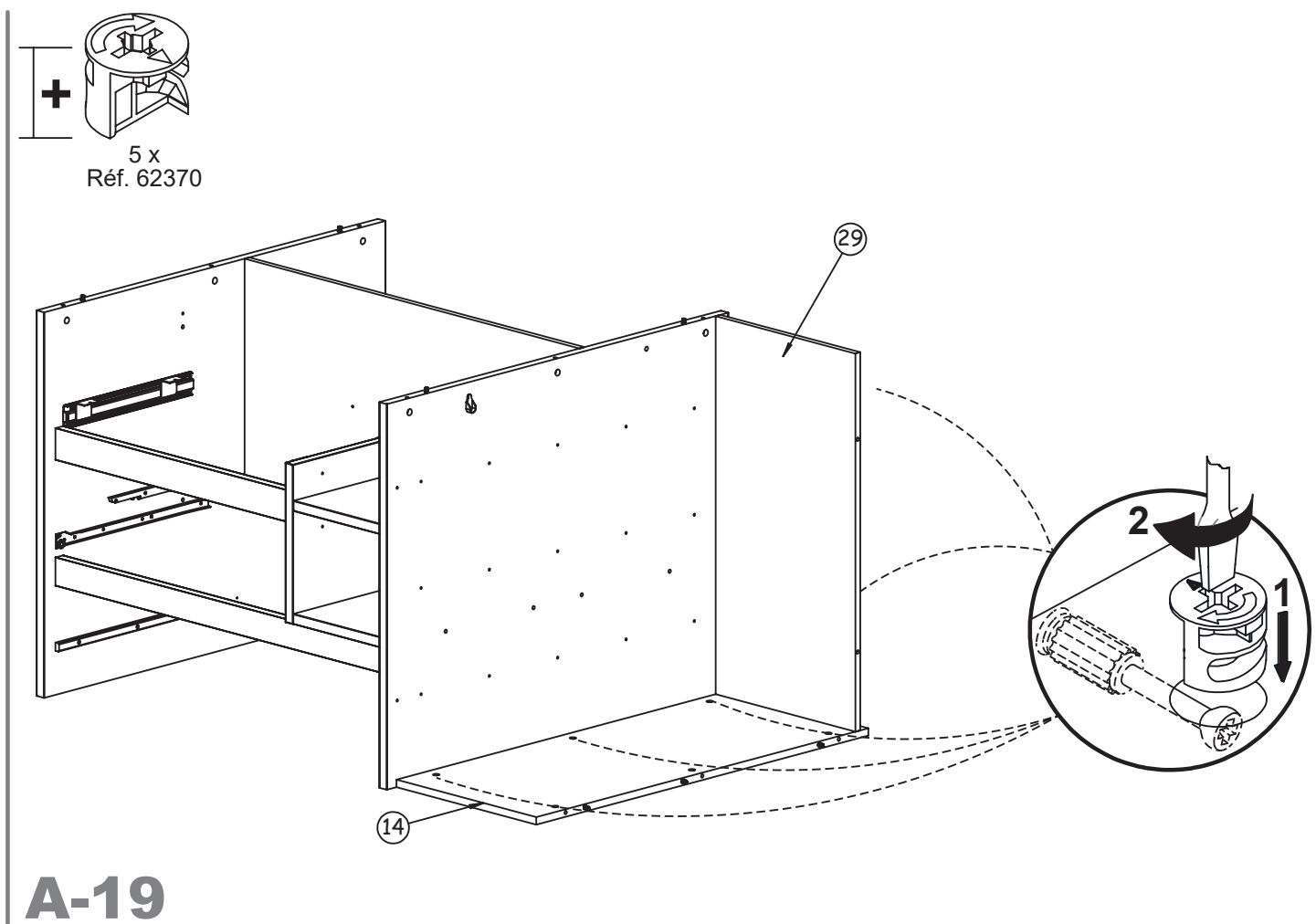
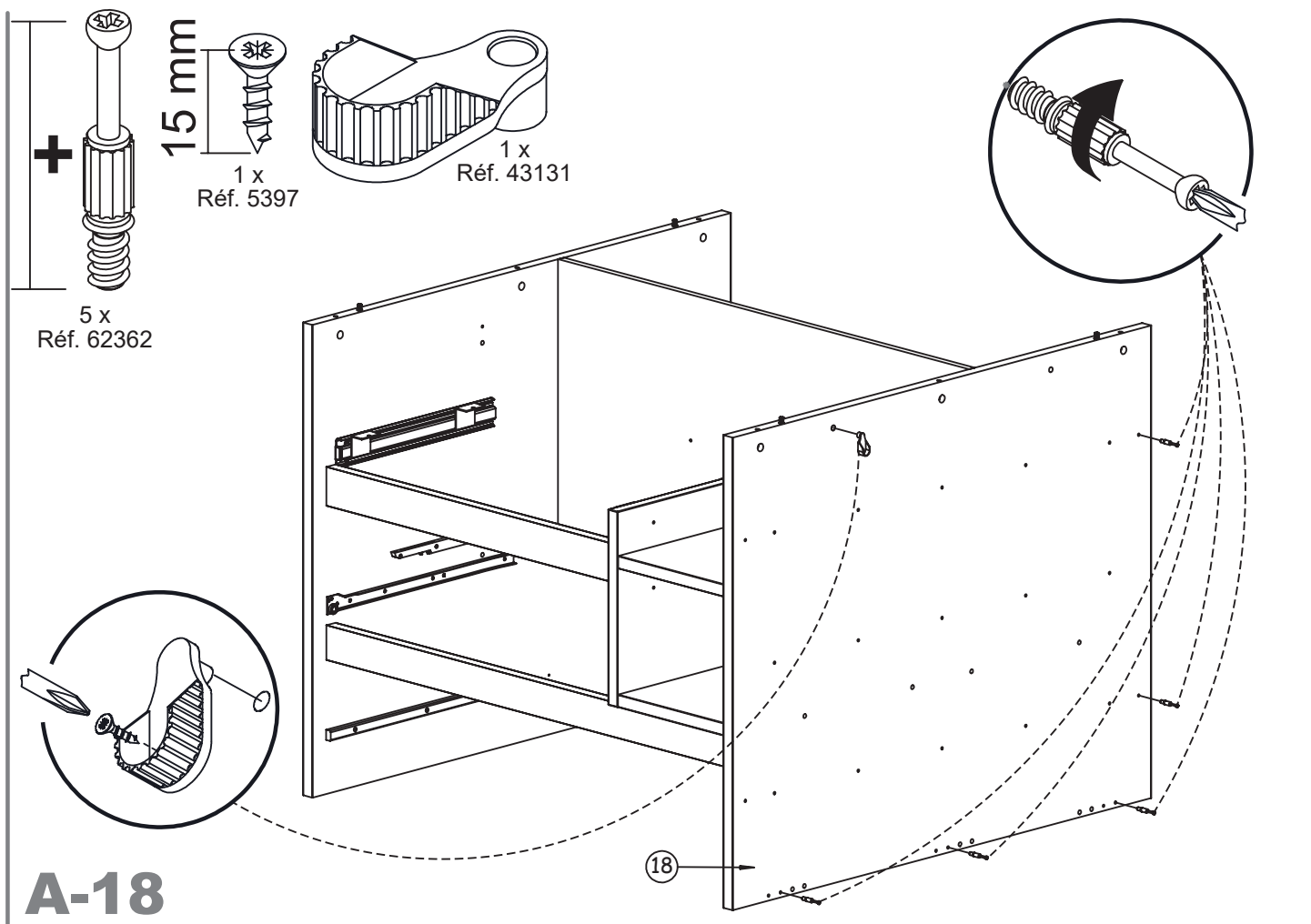

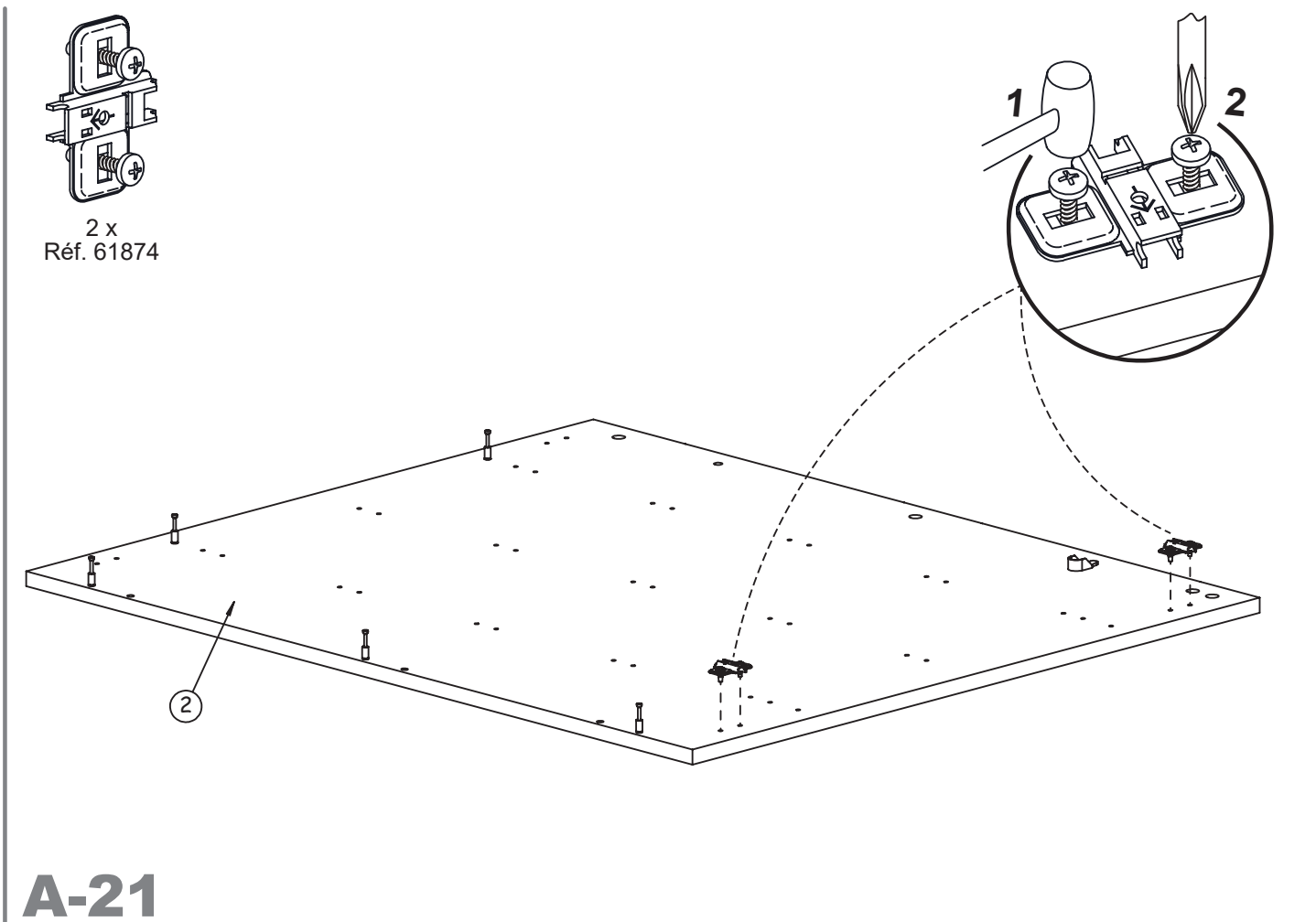
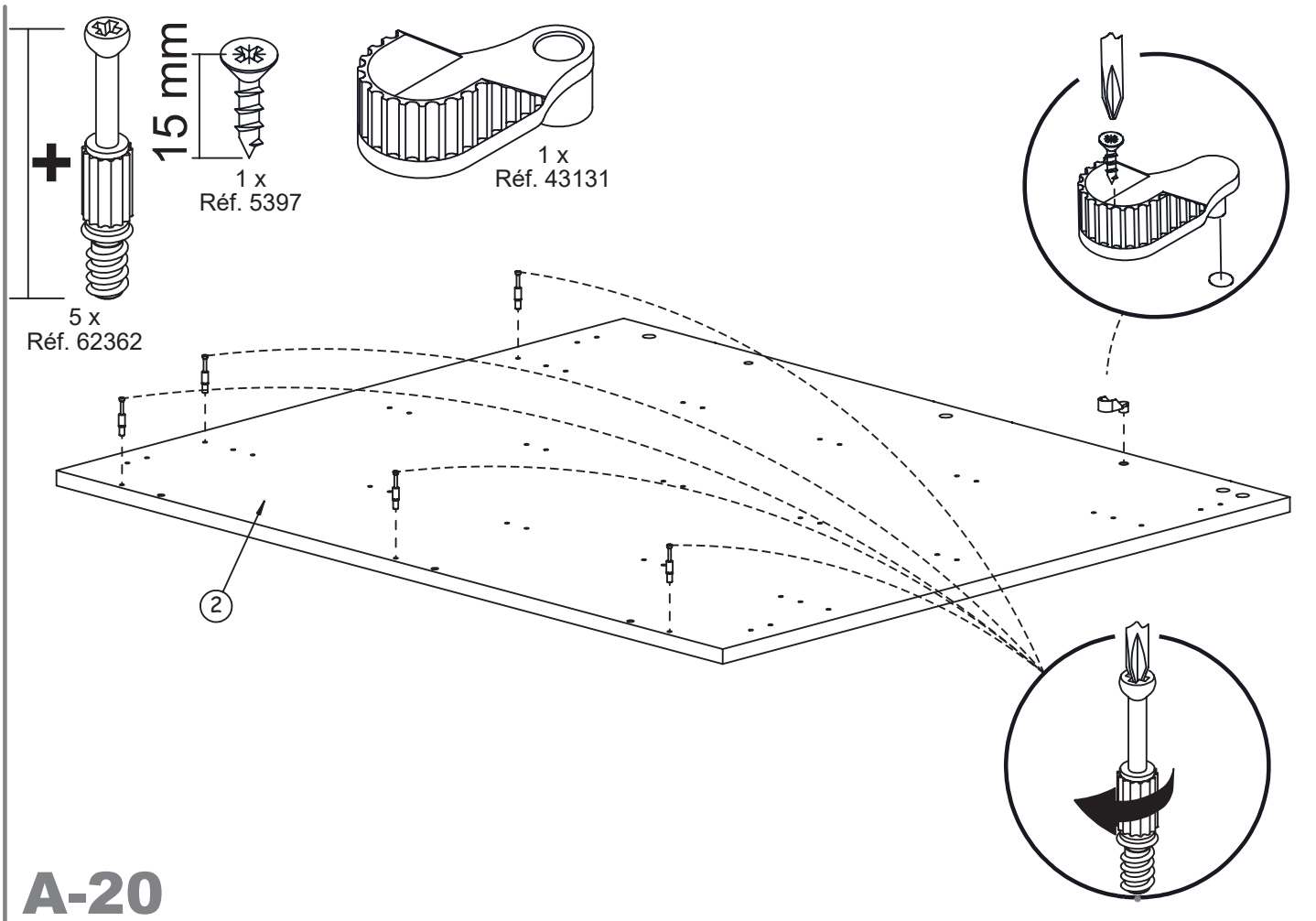

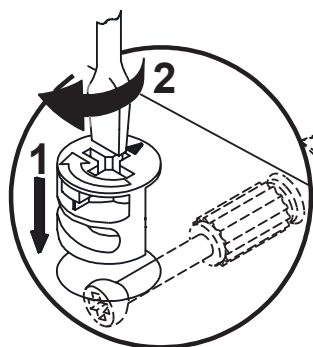
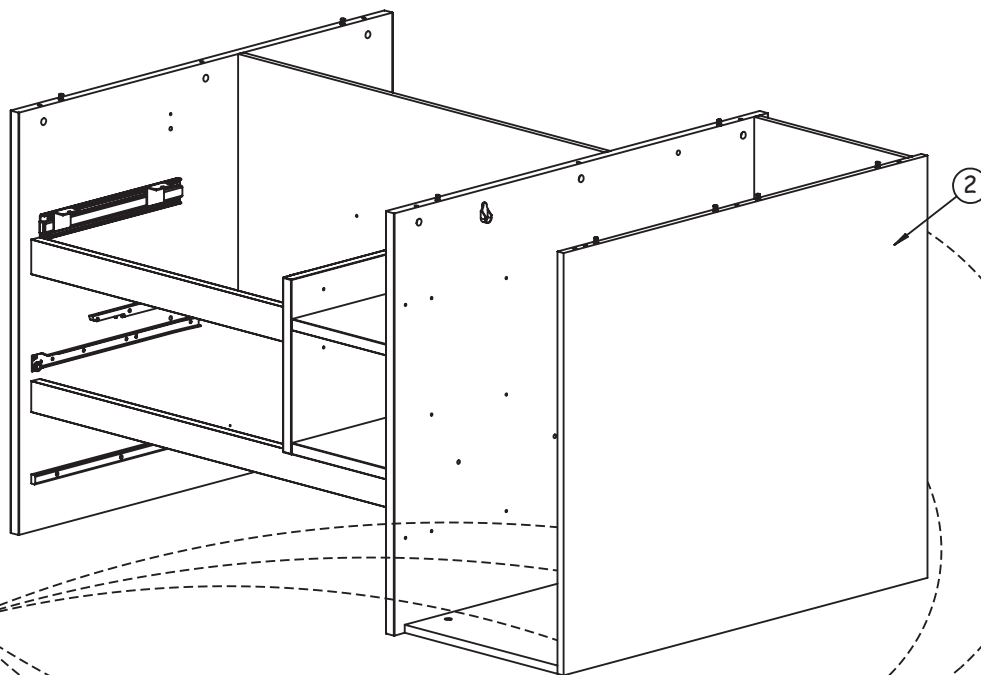
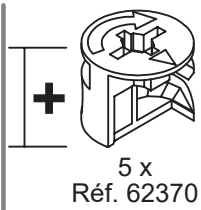

A-22

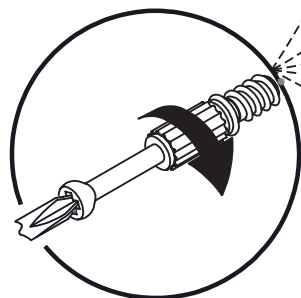
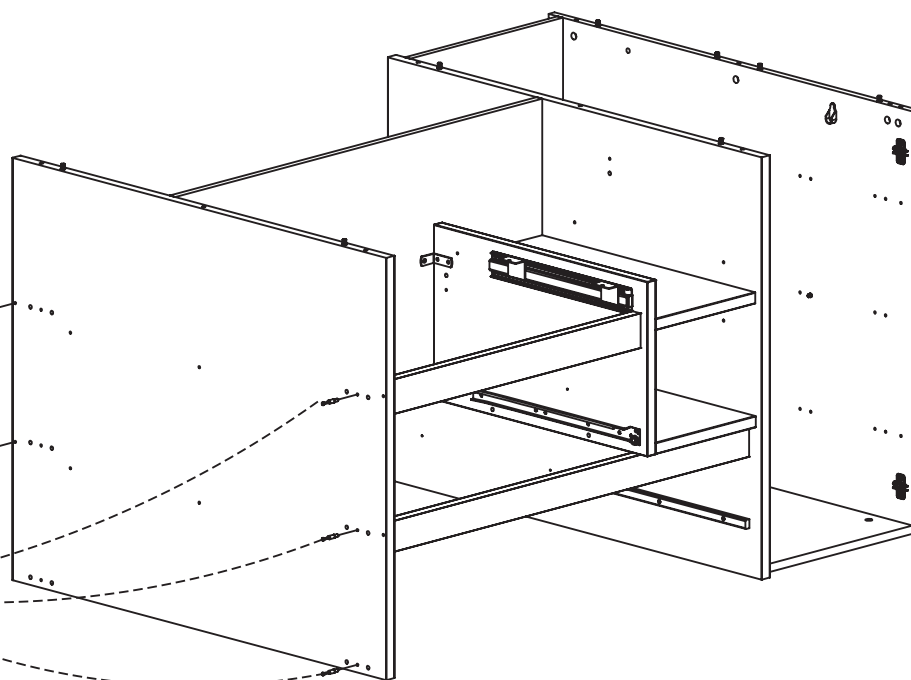
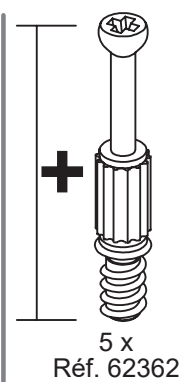

A-23

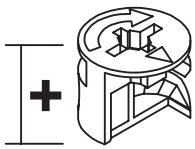

2 x
Réf. 62370

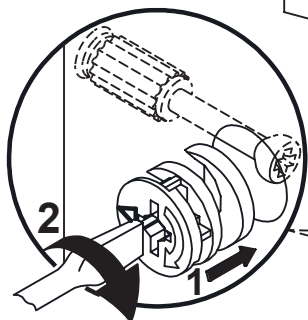
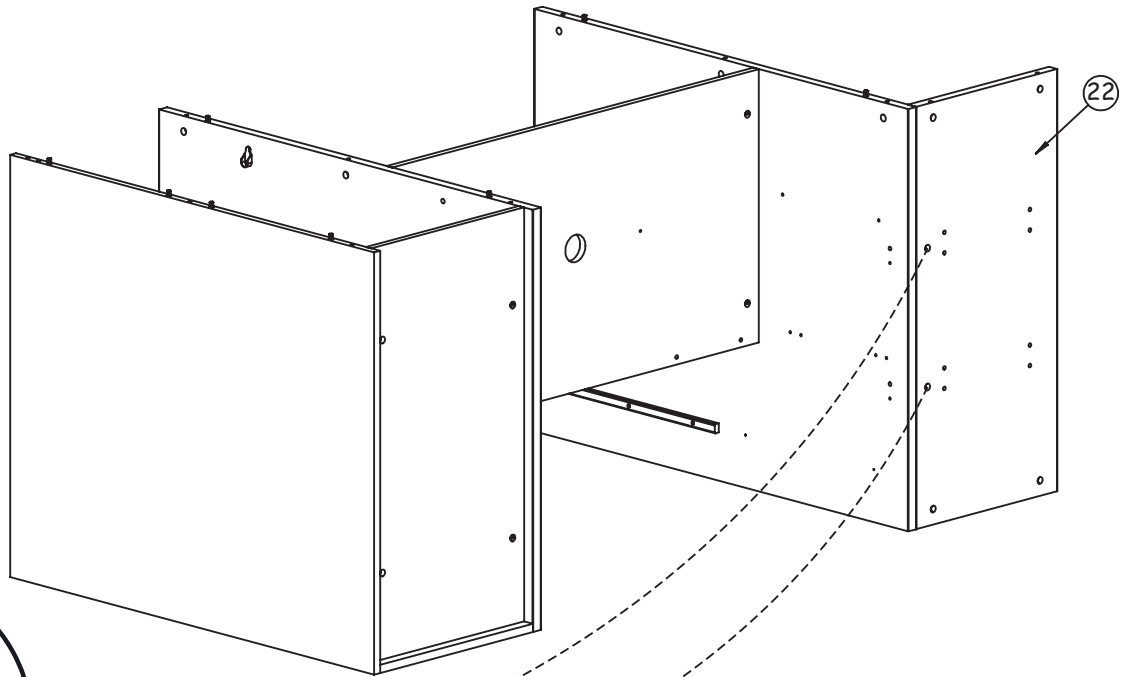

A-24

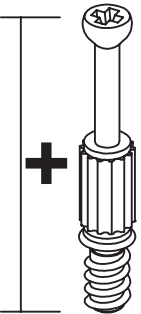

3 x
Réf. 62362

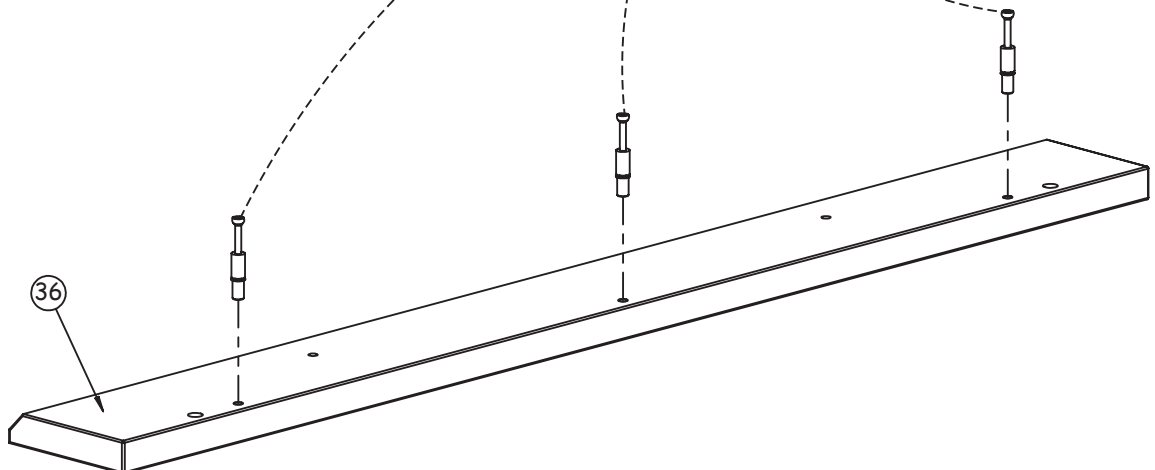
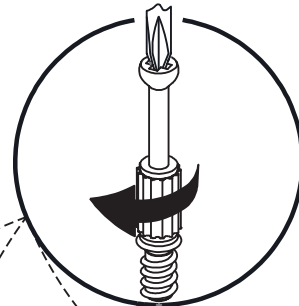

A-25

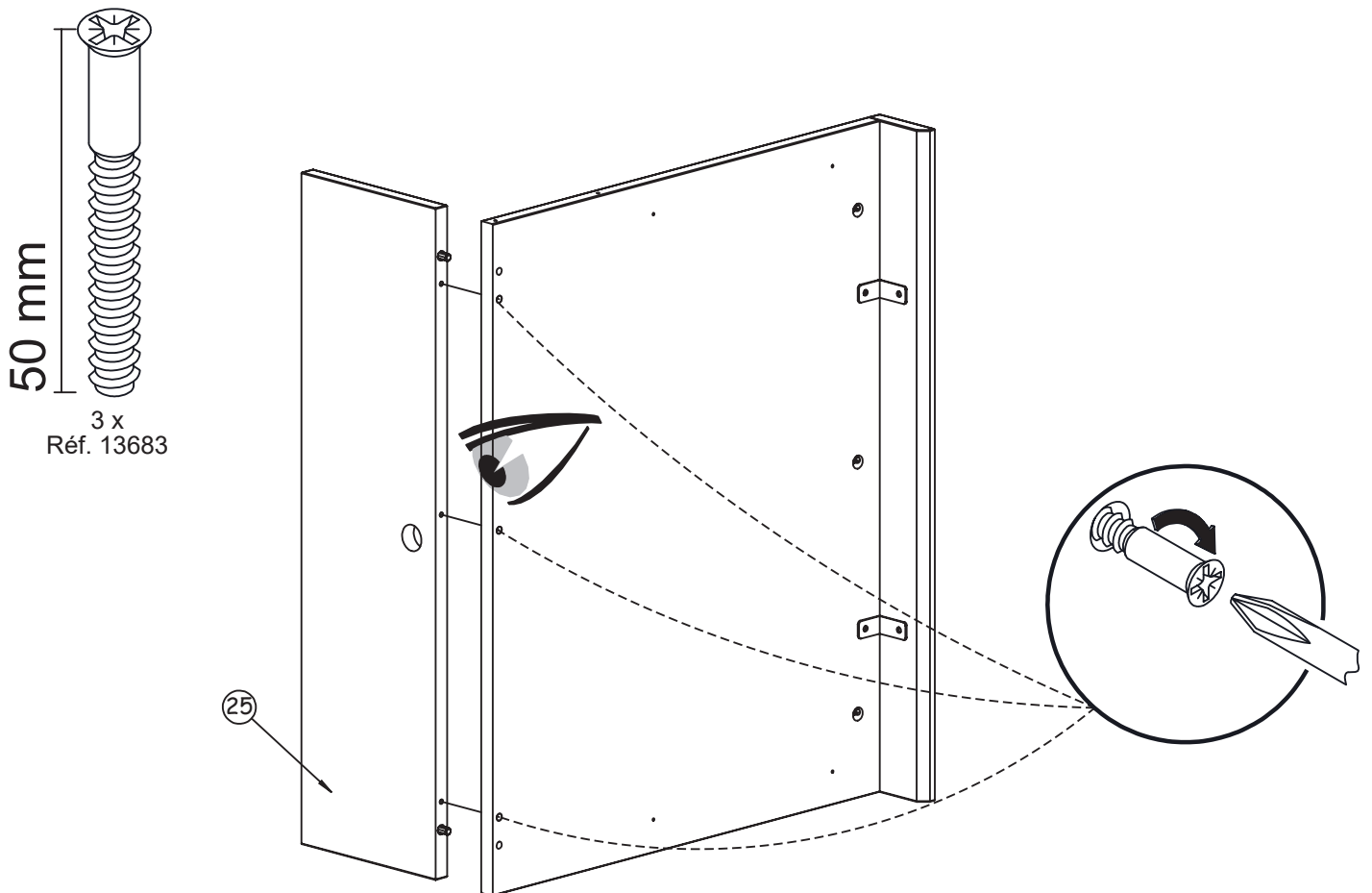
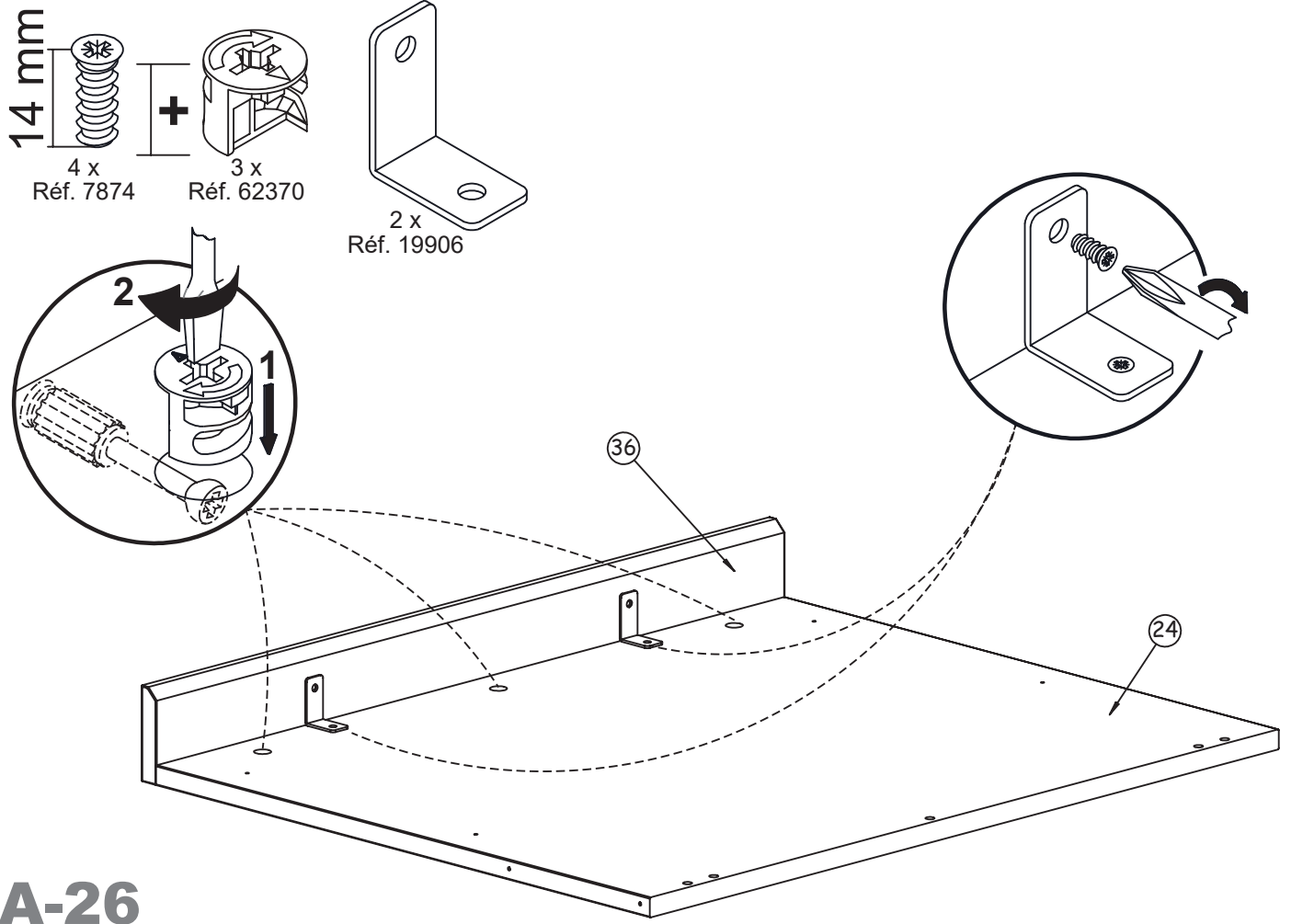

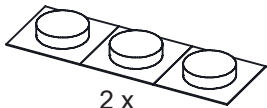

2 x
Réf. 62840

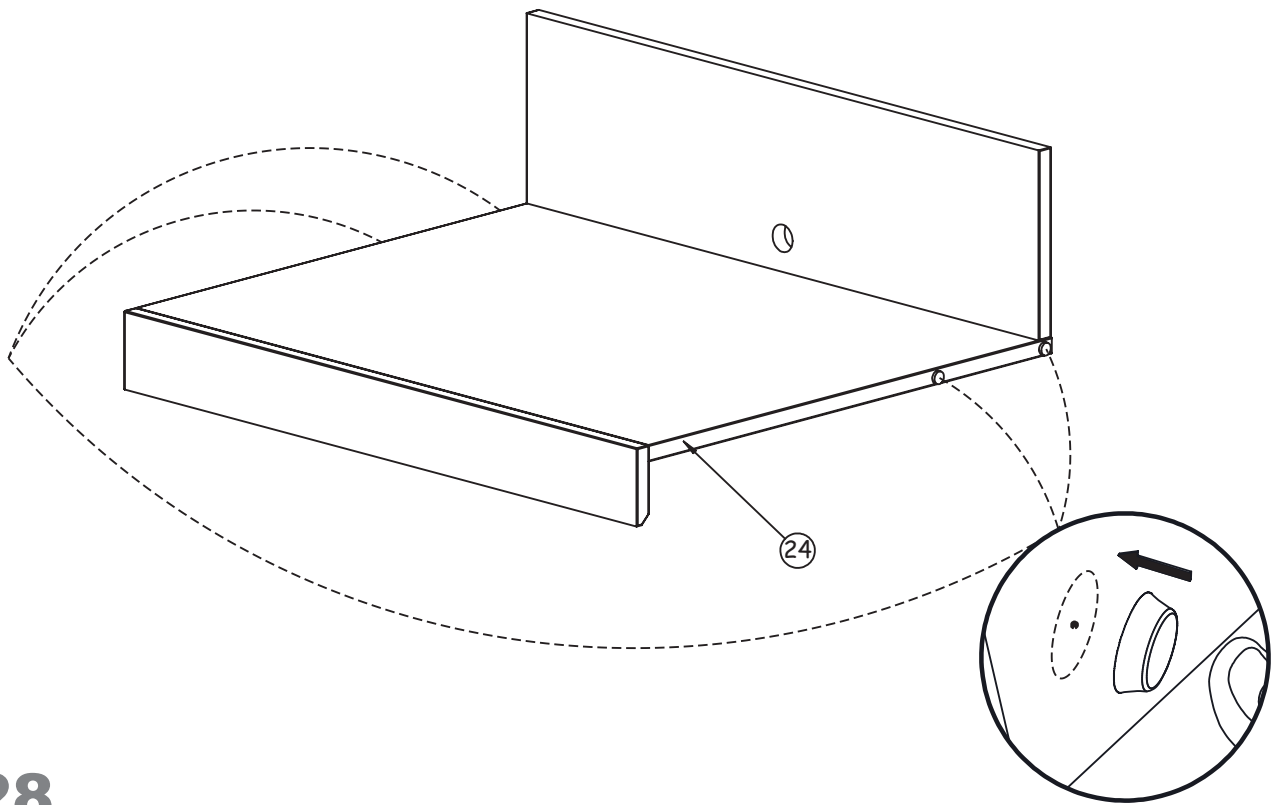

A-28

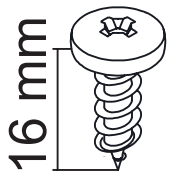

16 mm
4 x
Réf. 48050

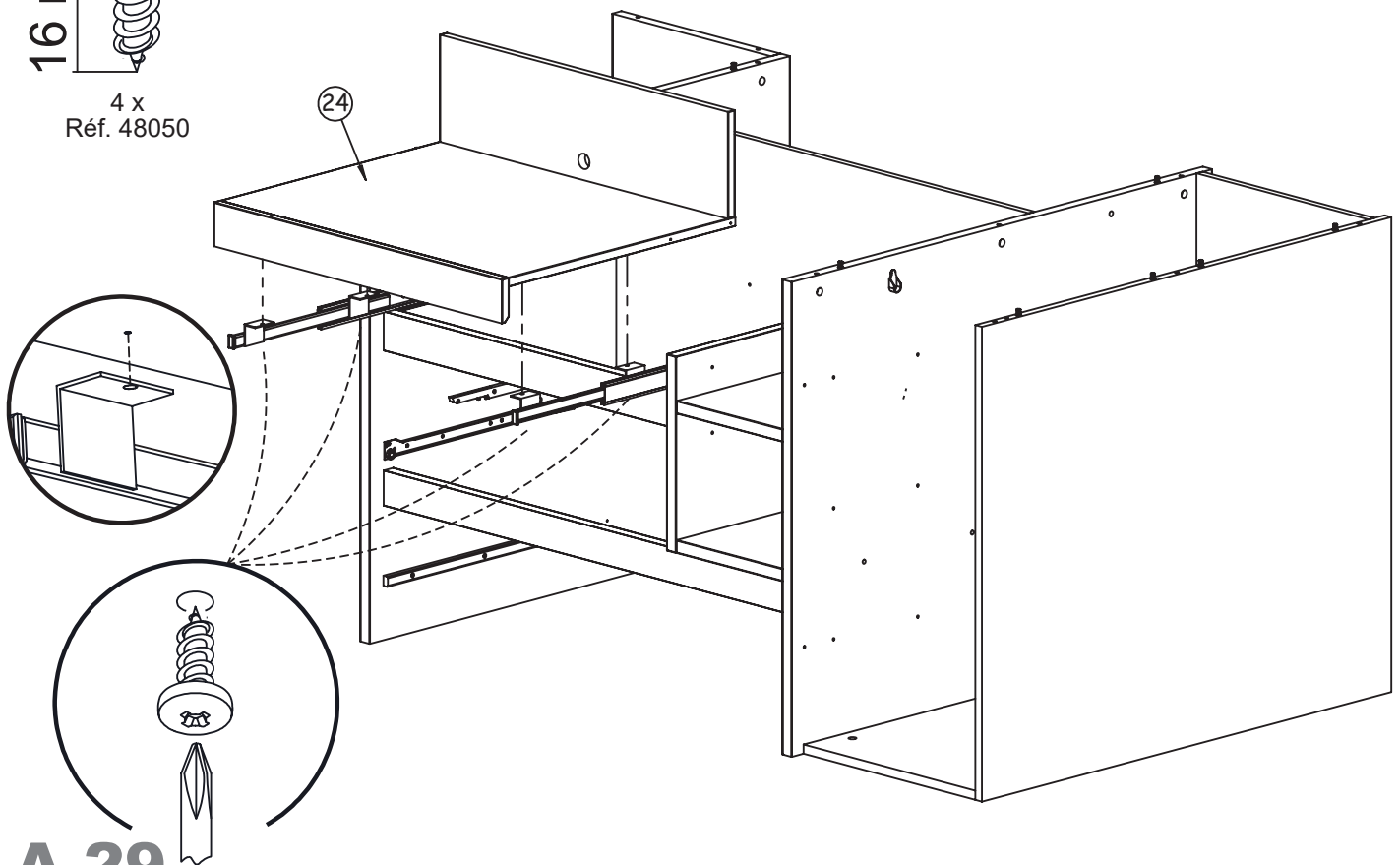

A-29

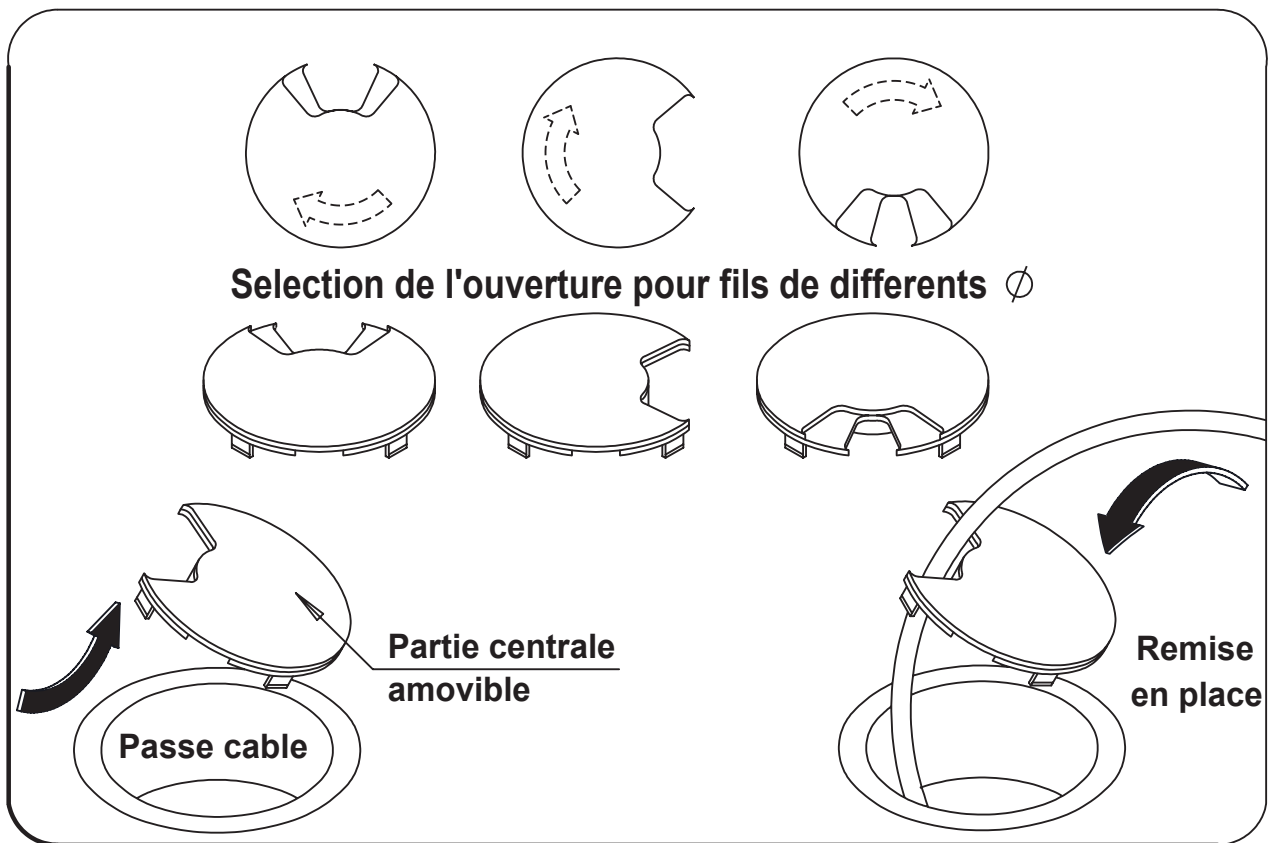
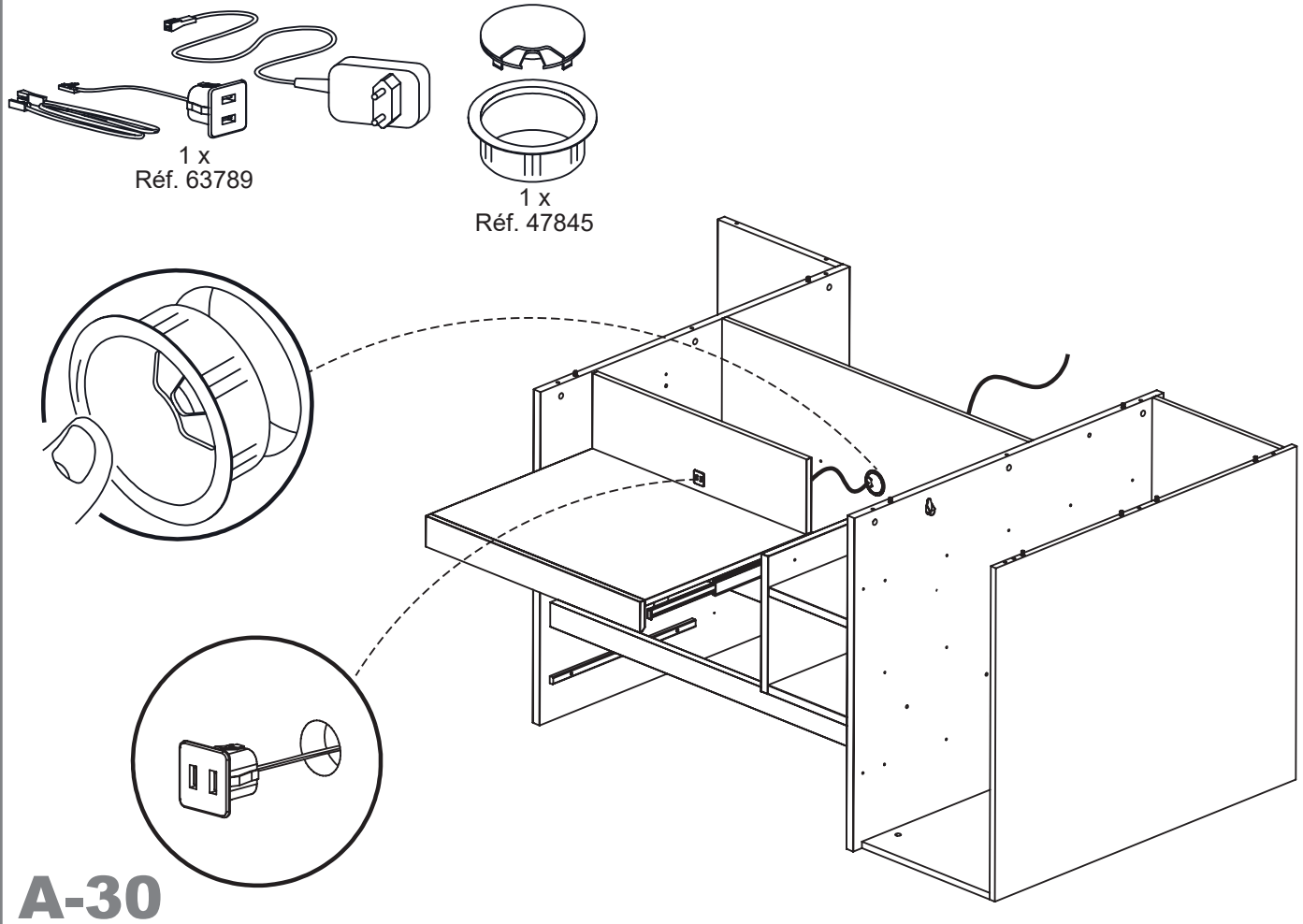

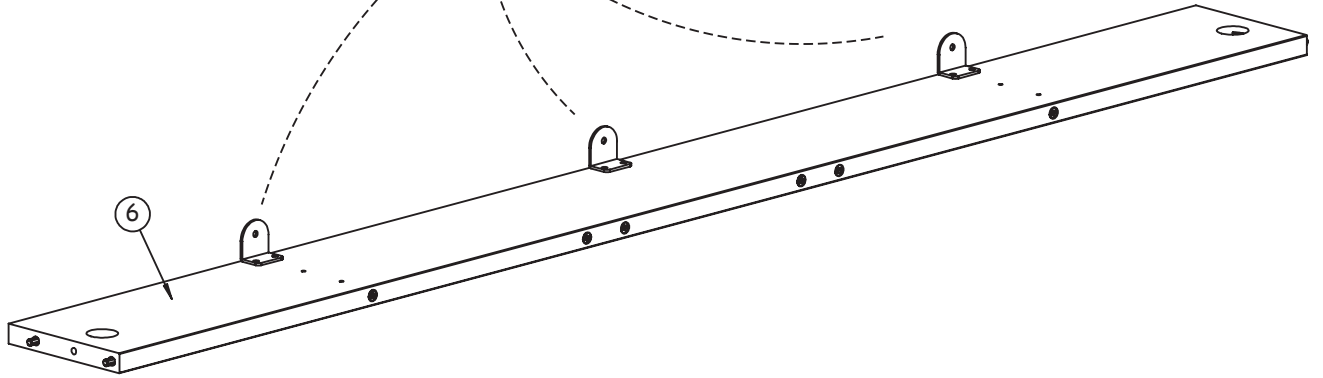
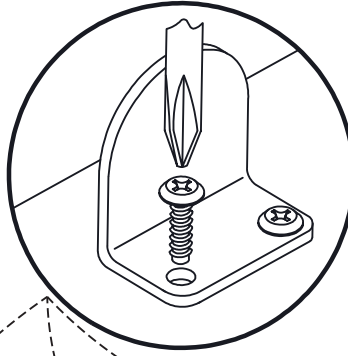
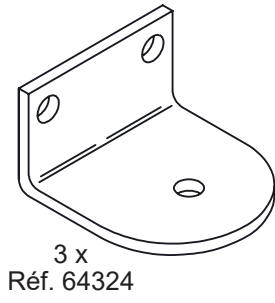
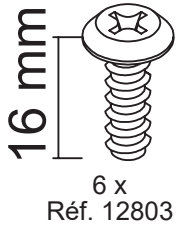

A-32

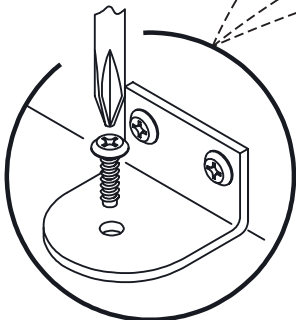
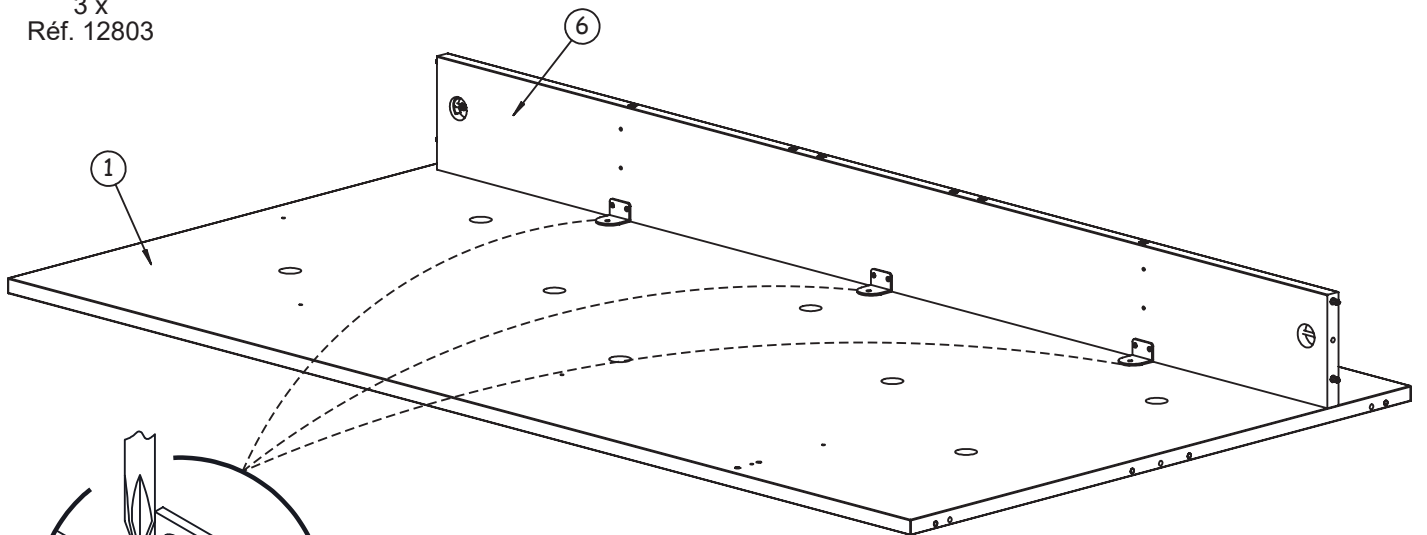
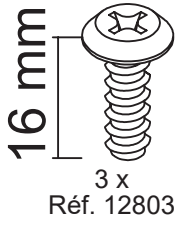

A-33

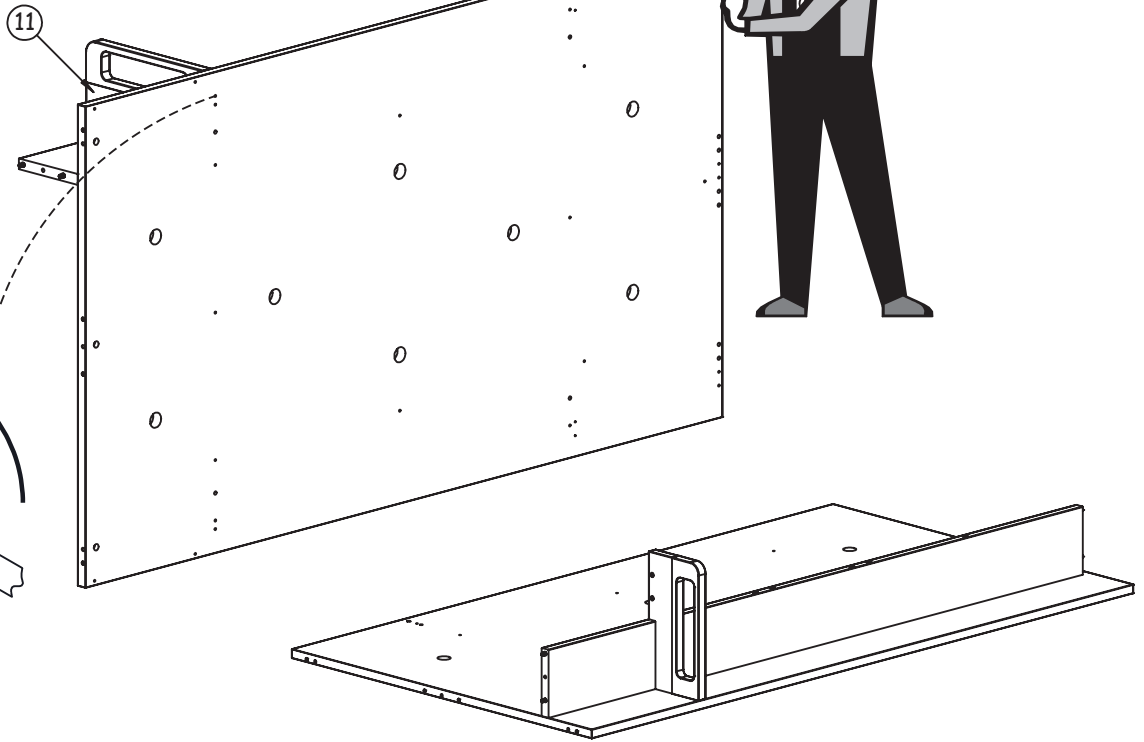
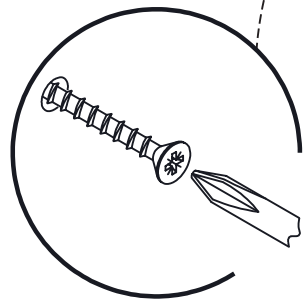
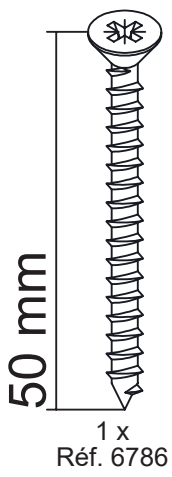

A-34

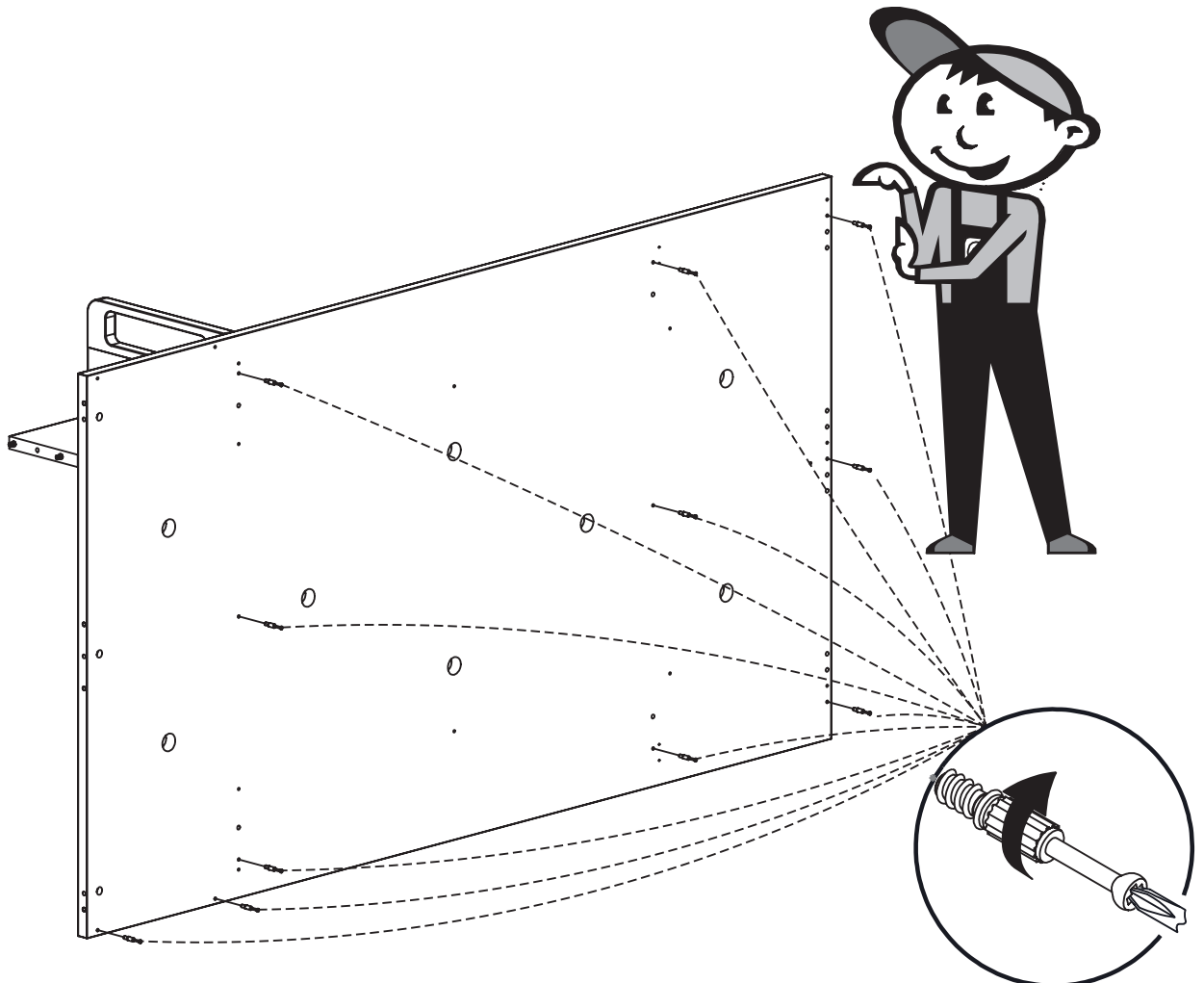
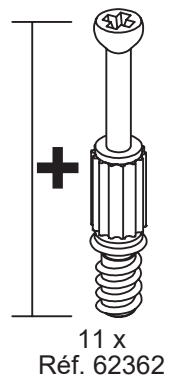

A-35

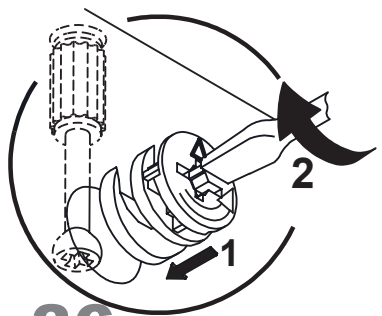
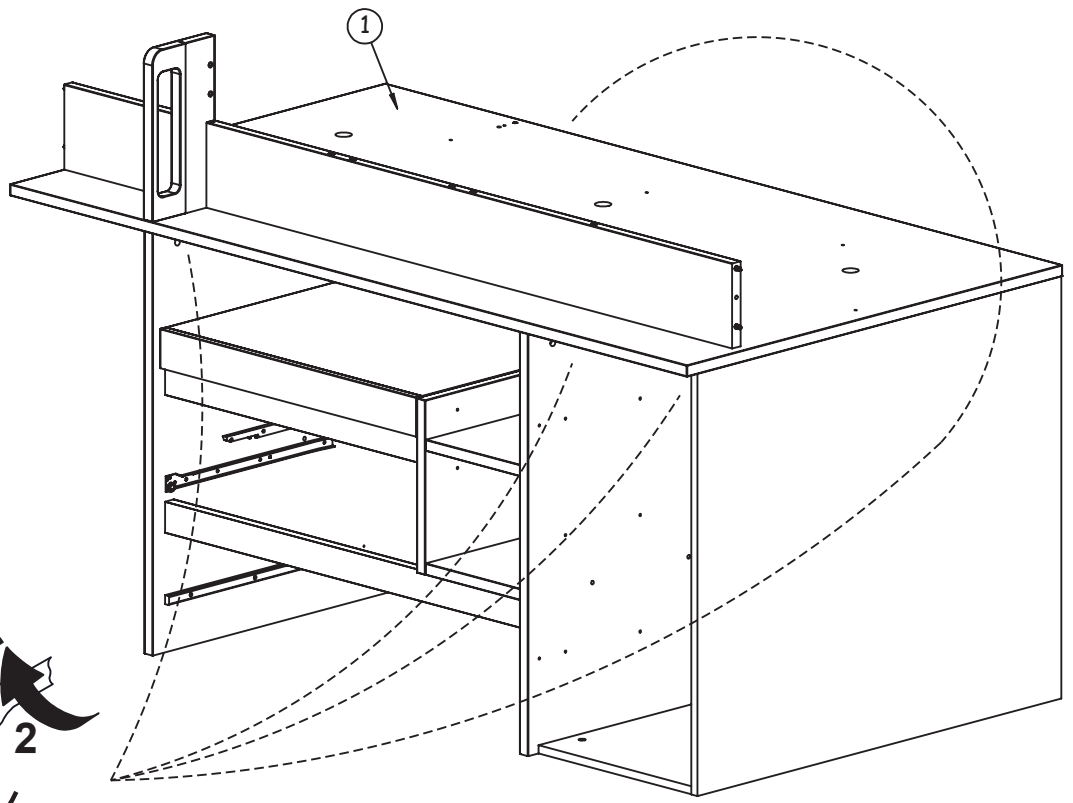
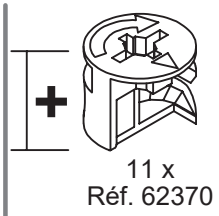

A-36

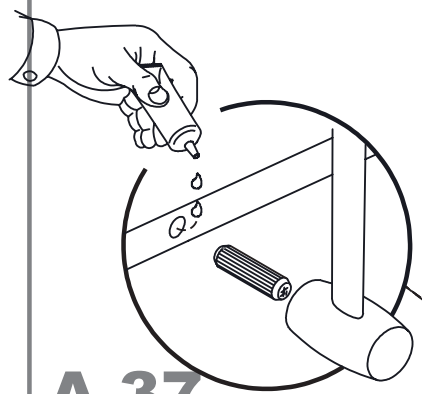
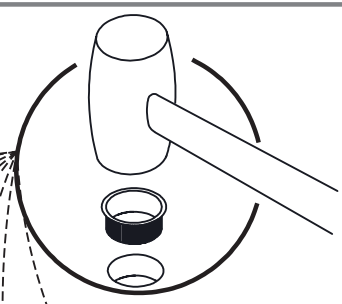
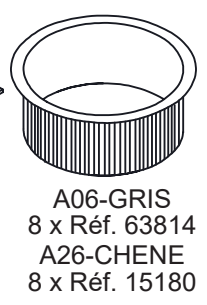
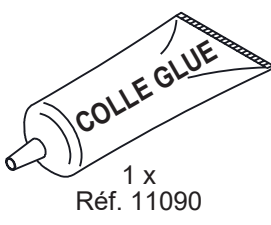
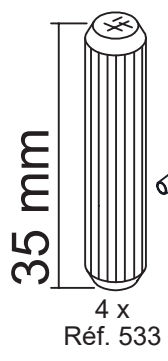

A-37

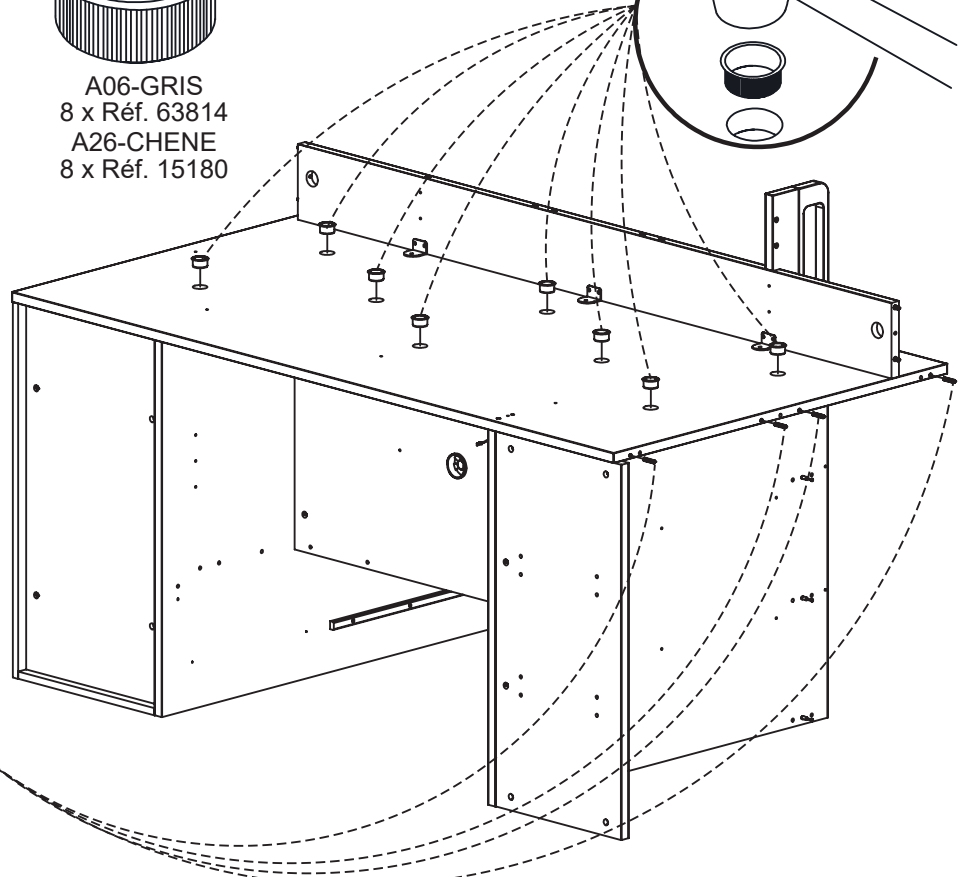

16 mm
8 x
Réf. 12803

4 x
Réf. 64324

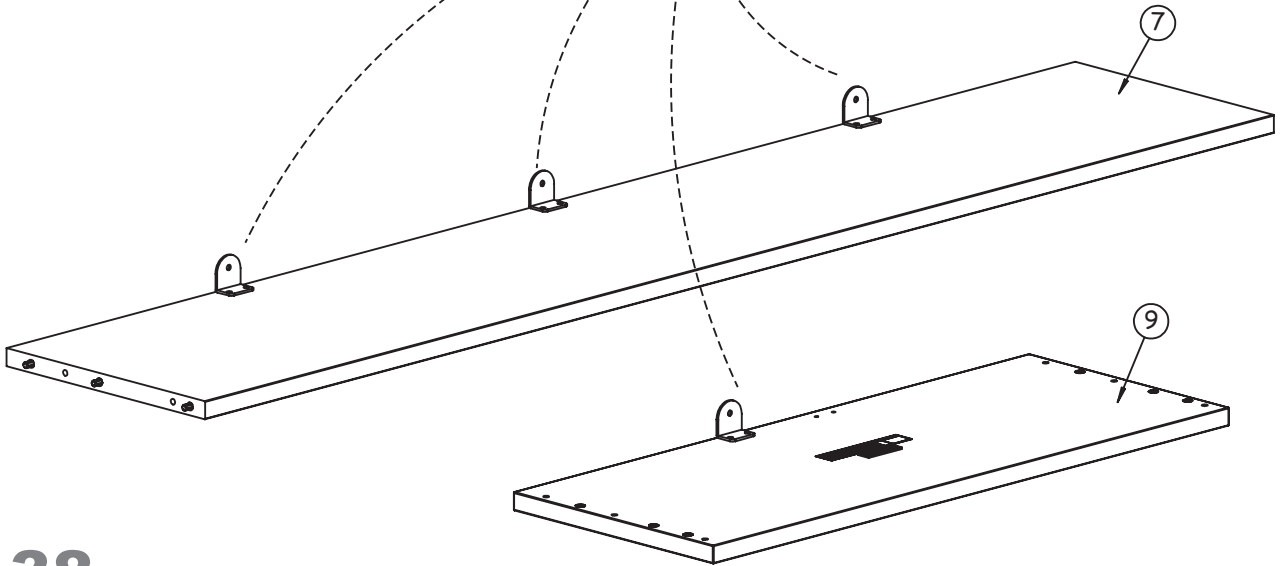
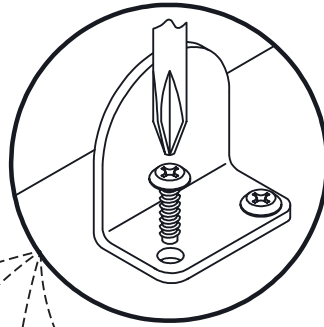

A-38

43 mm
3 x
Réf. 22426

16 mm
2 x
Réf. 12803

3 x
Réf. 363

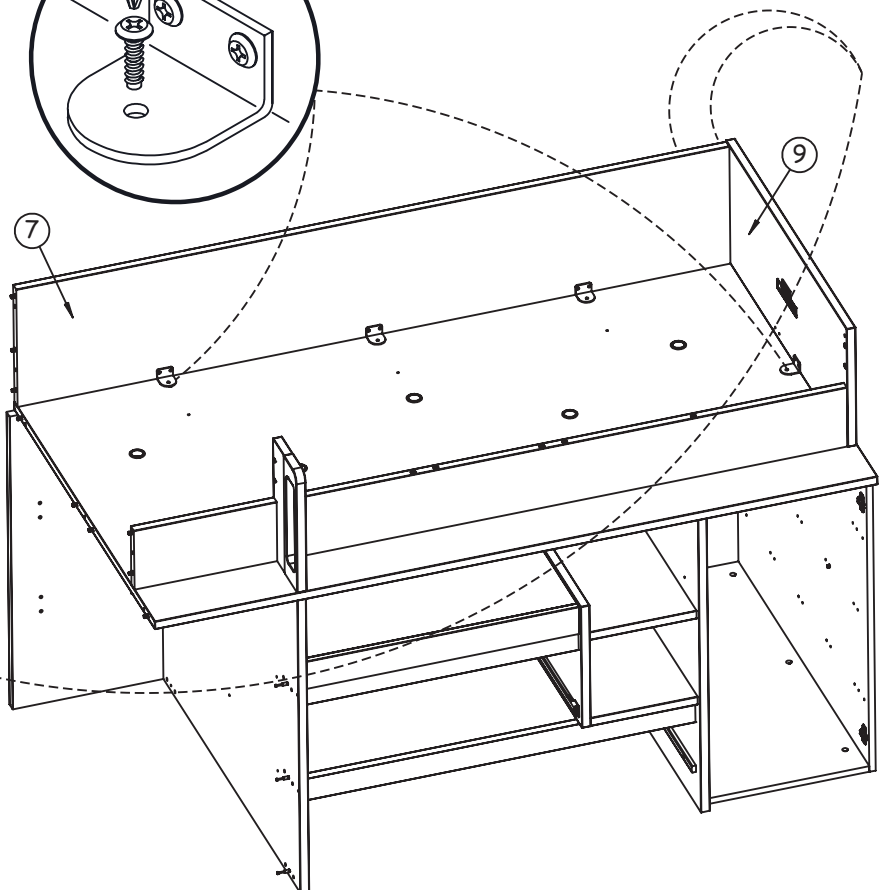
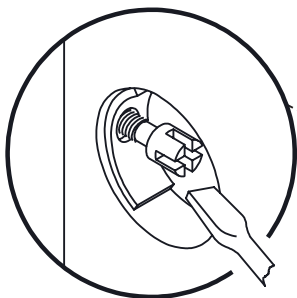
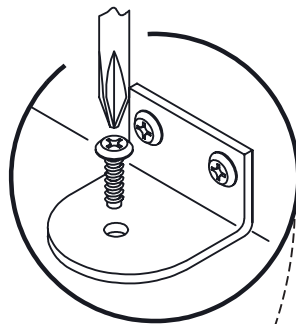

A-39

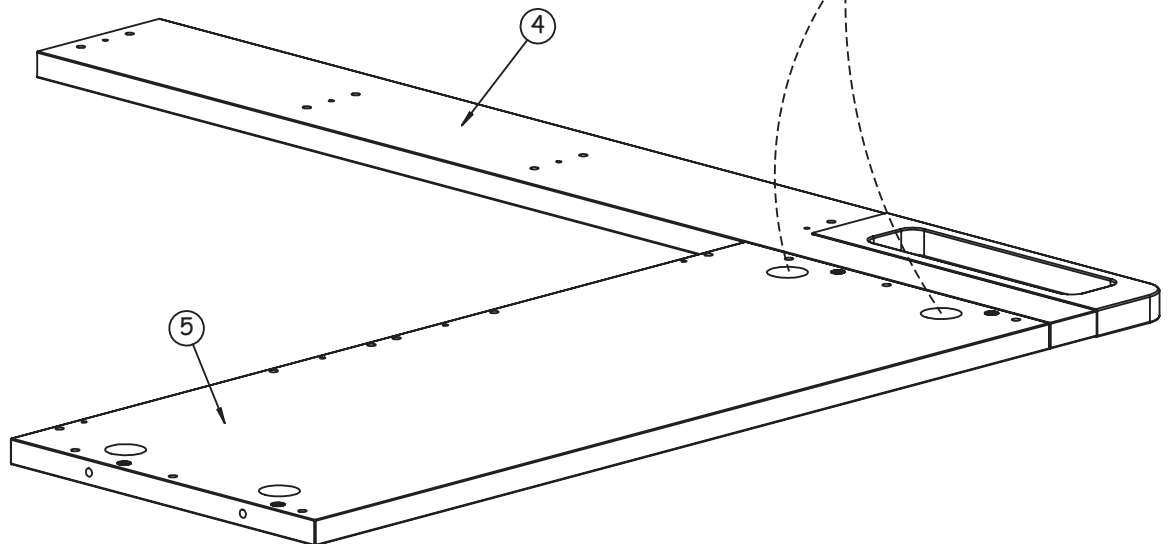
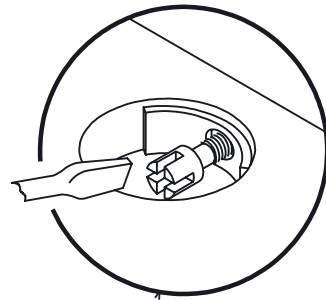
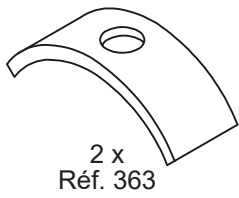
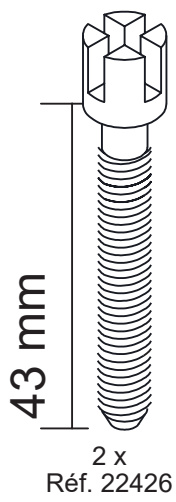

A-40

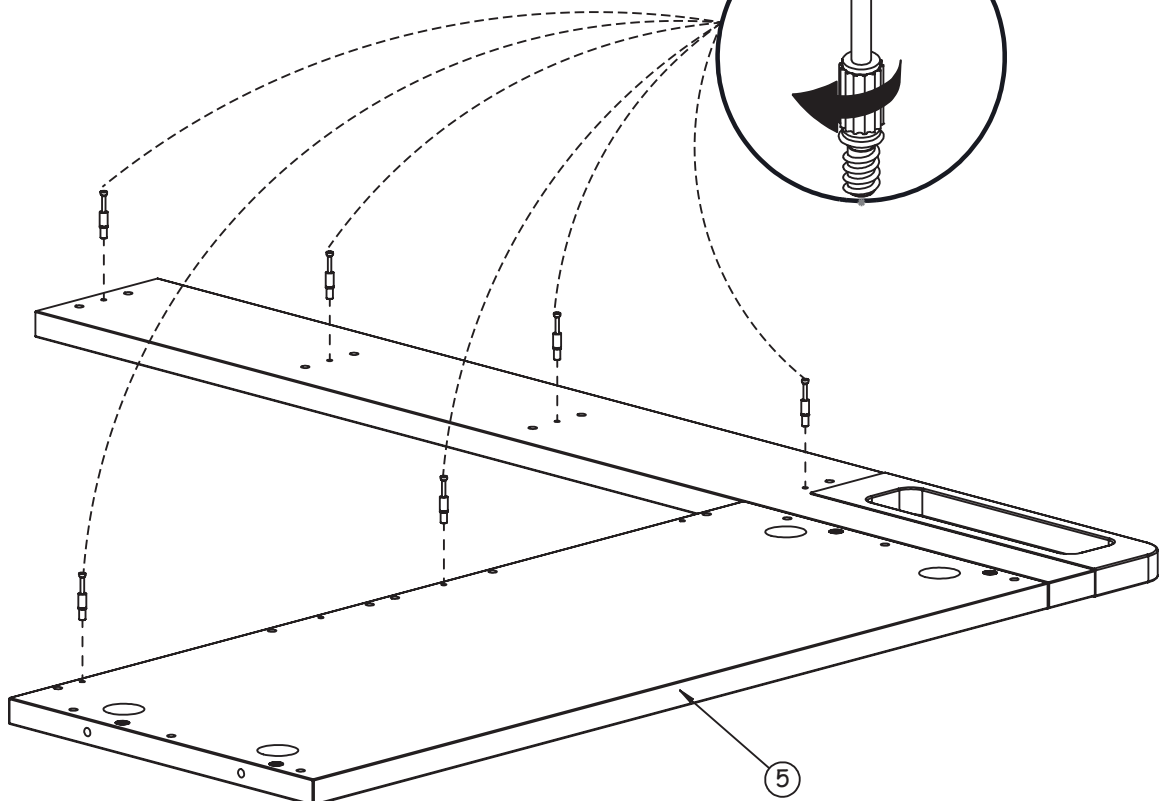
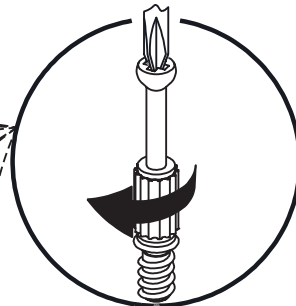
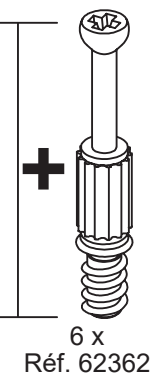

A-41

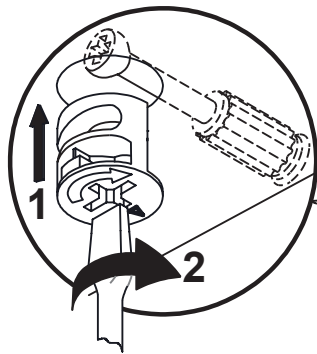
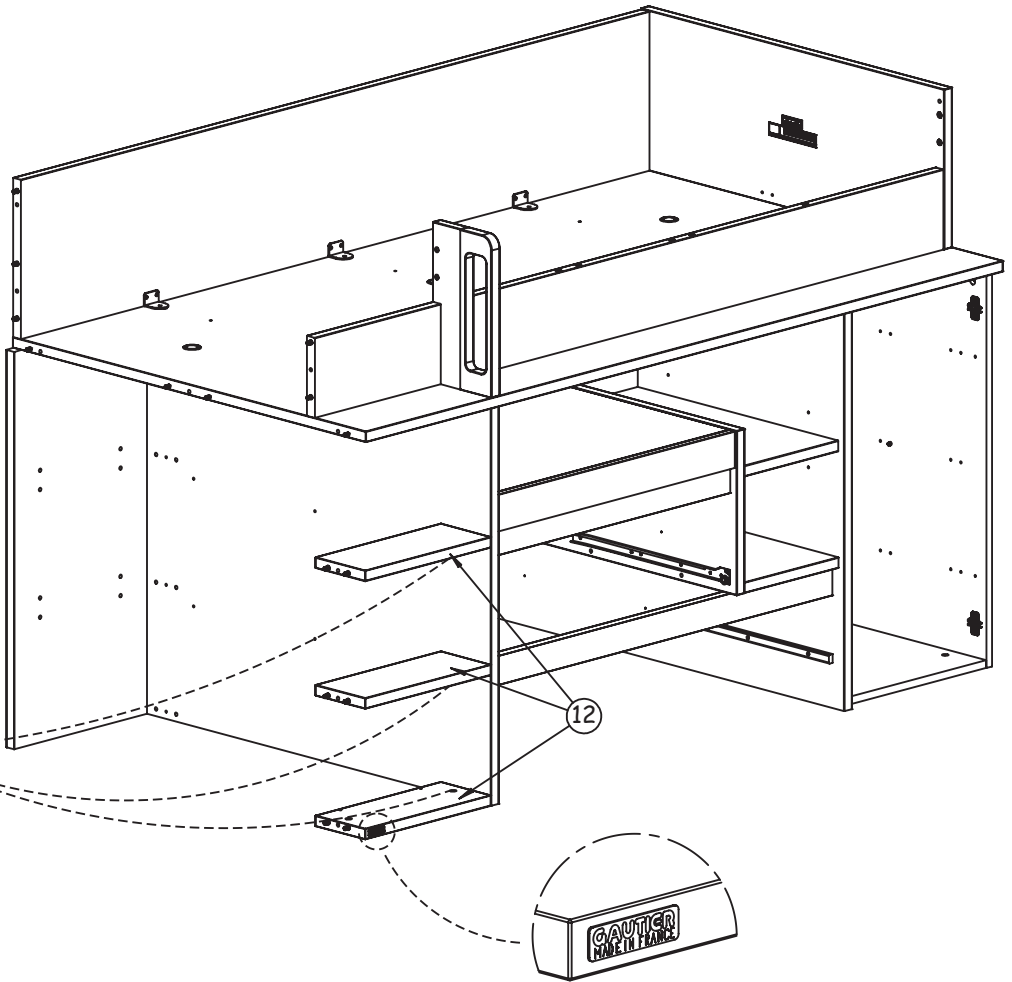
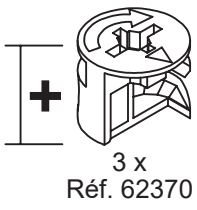

A-42

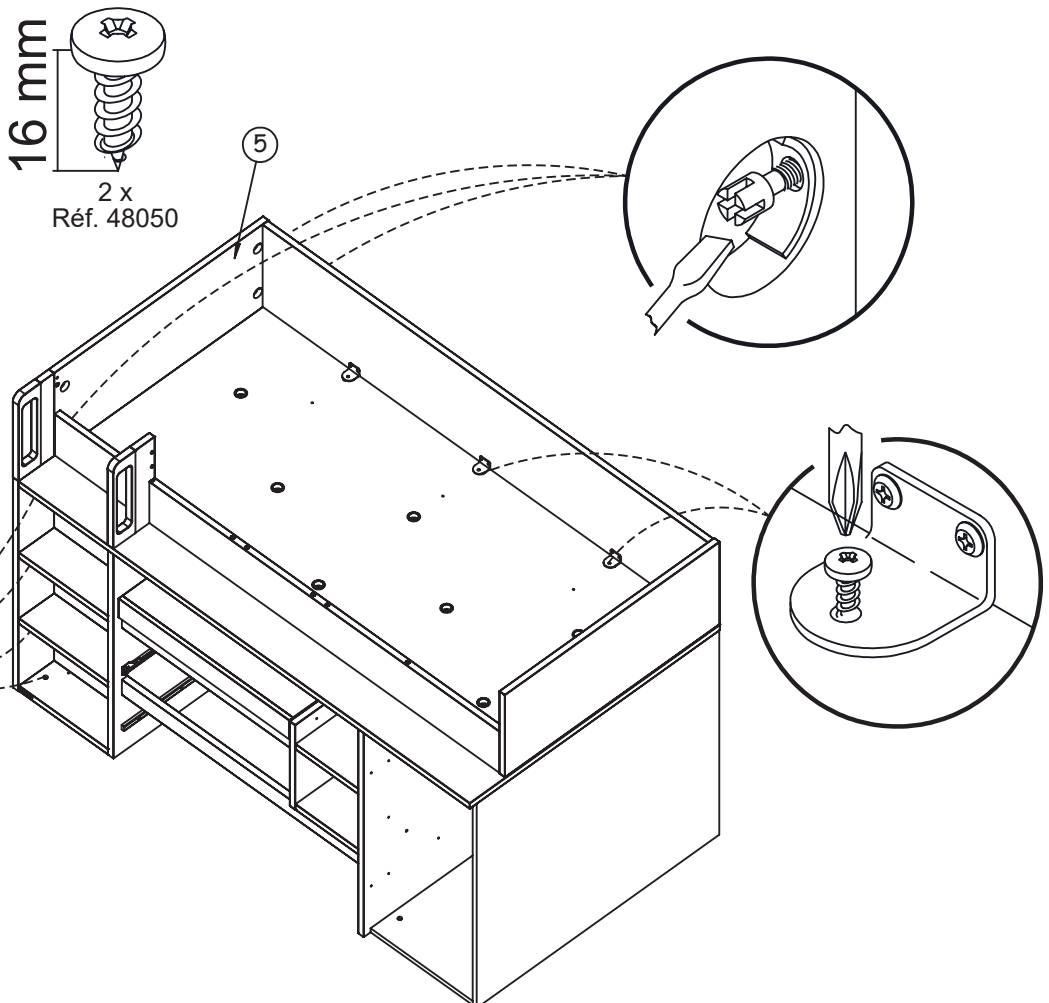
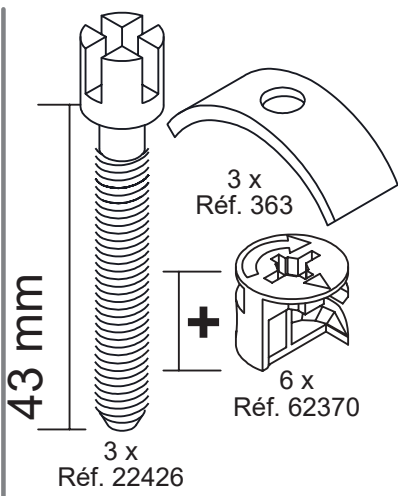

A-43

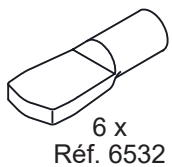

6 x
Réf. 6532

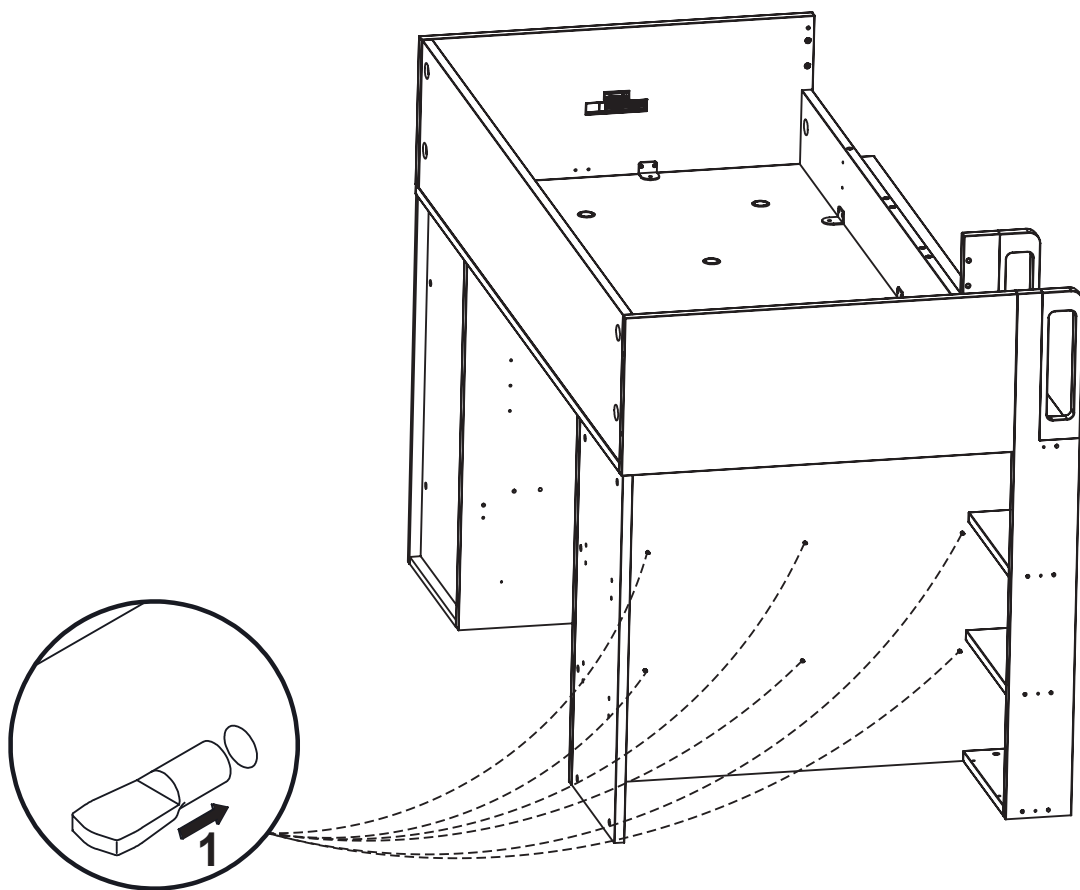

A-44

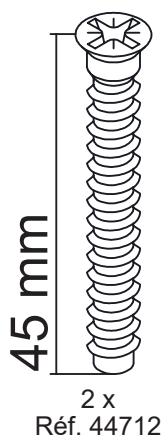

45 mm
2 x
Réf. 44712

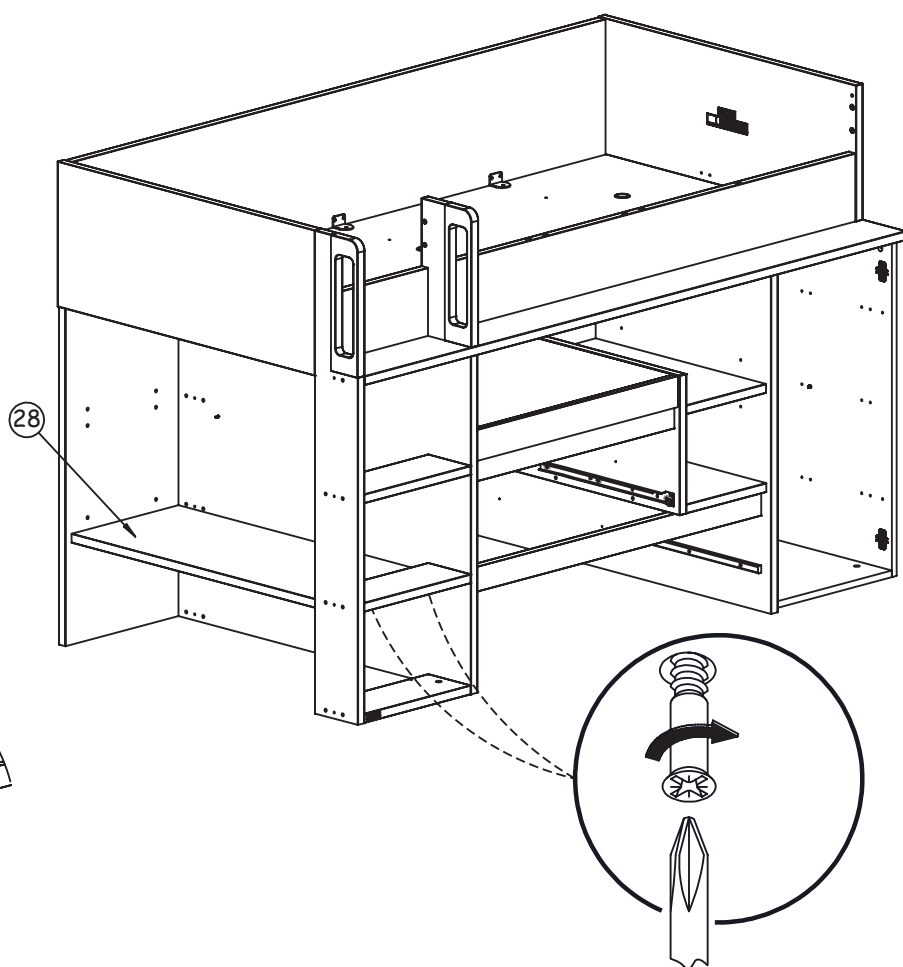
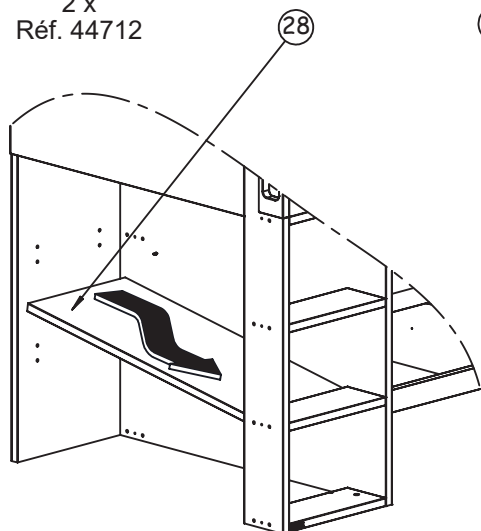

A-45

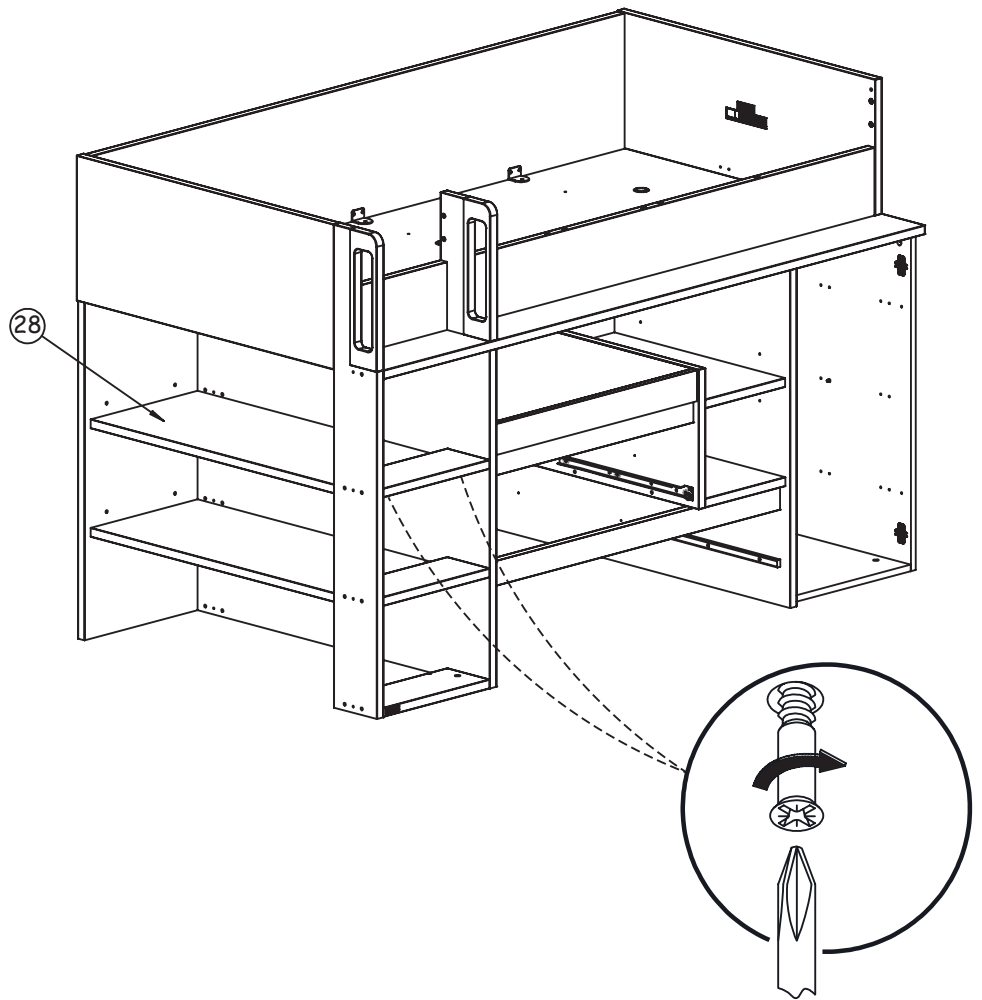
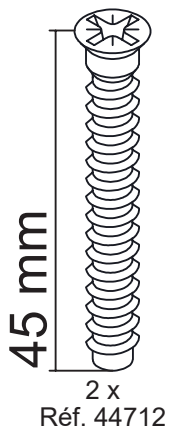

A-46

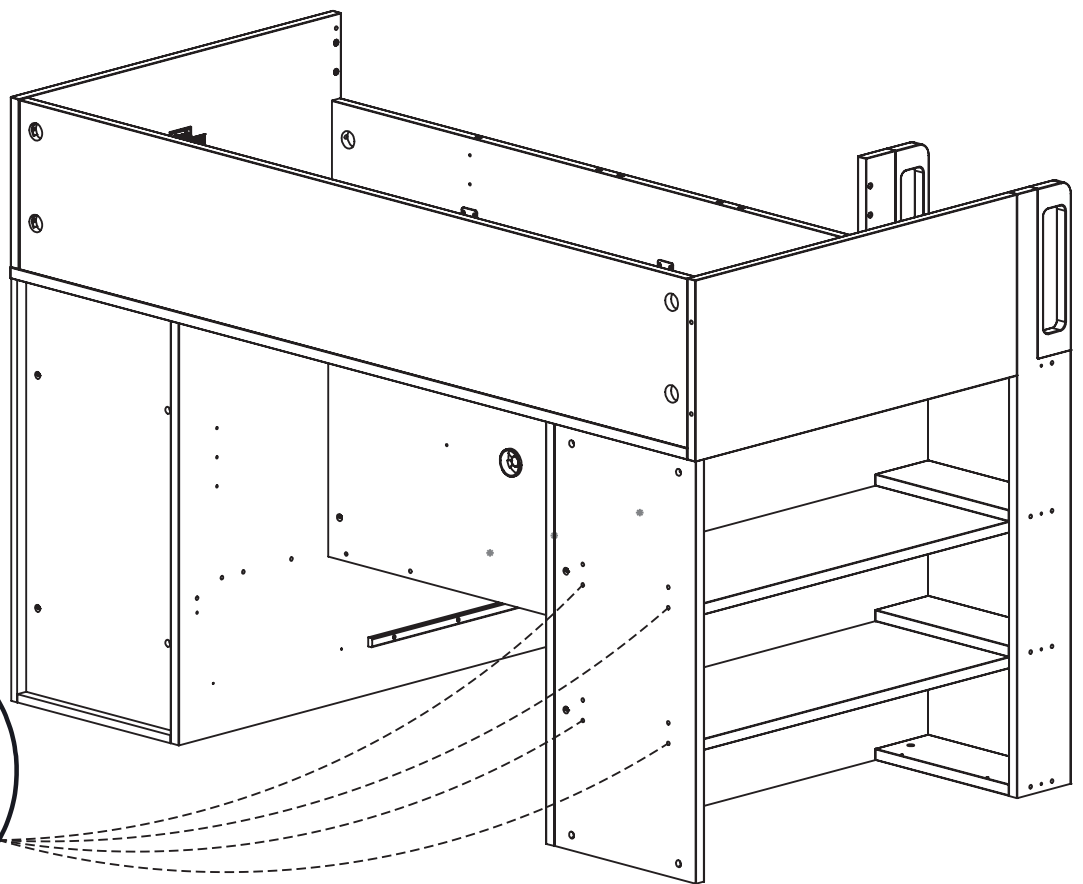
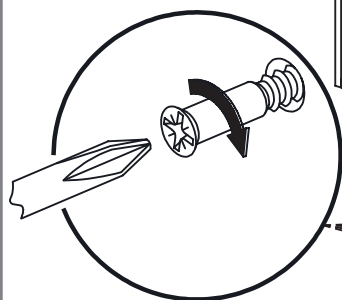
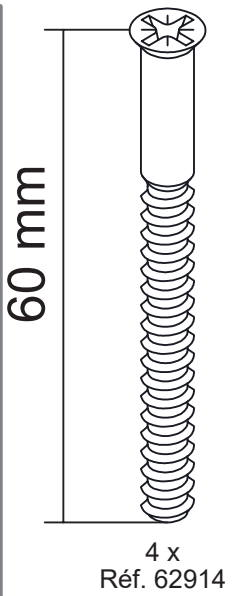

A-47

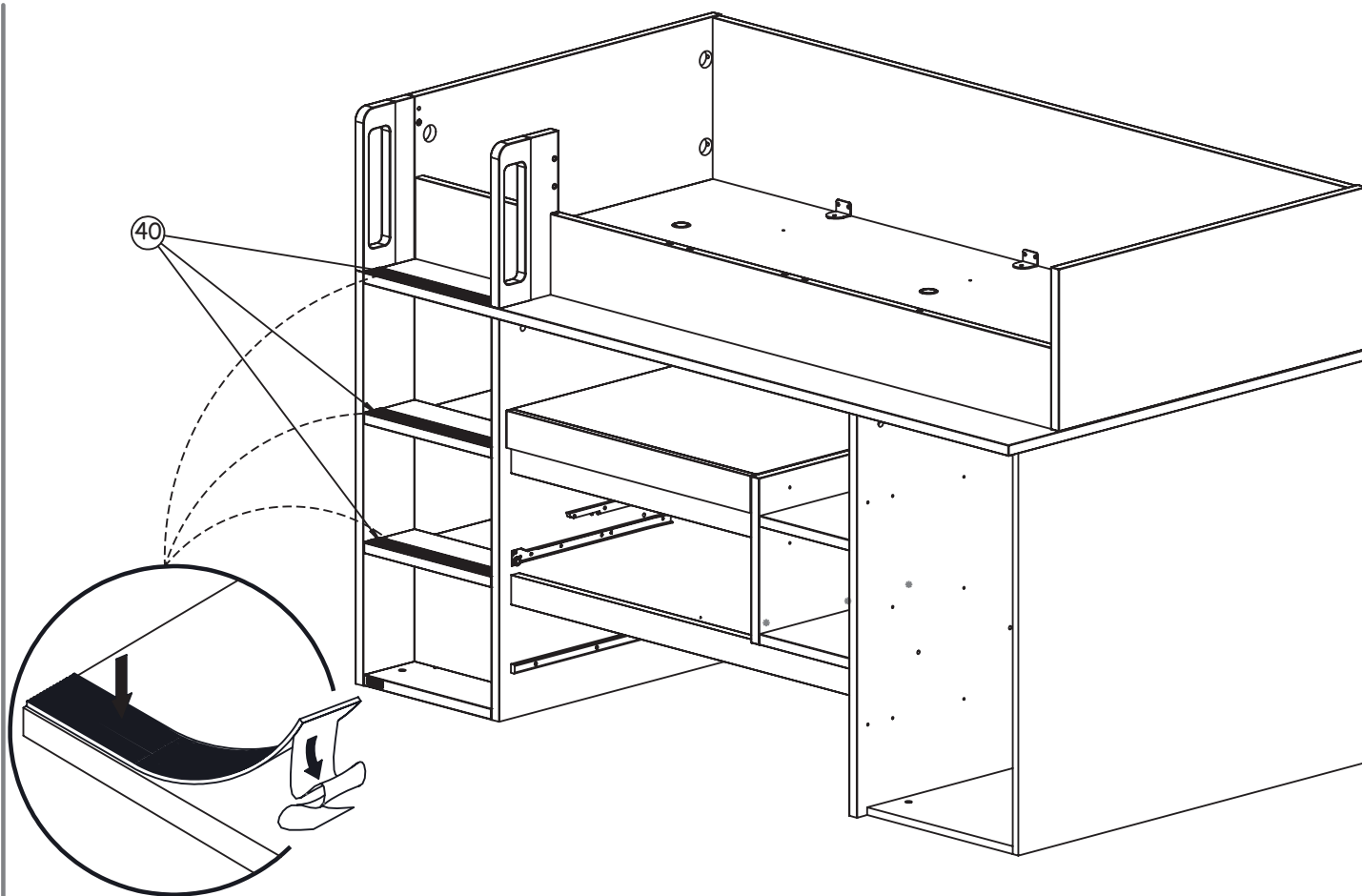

A-48

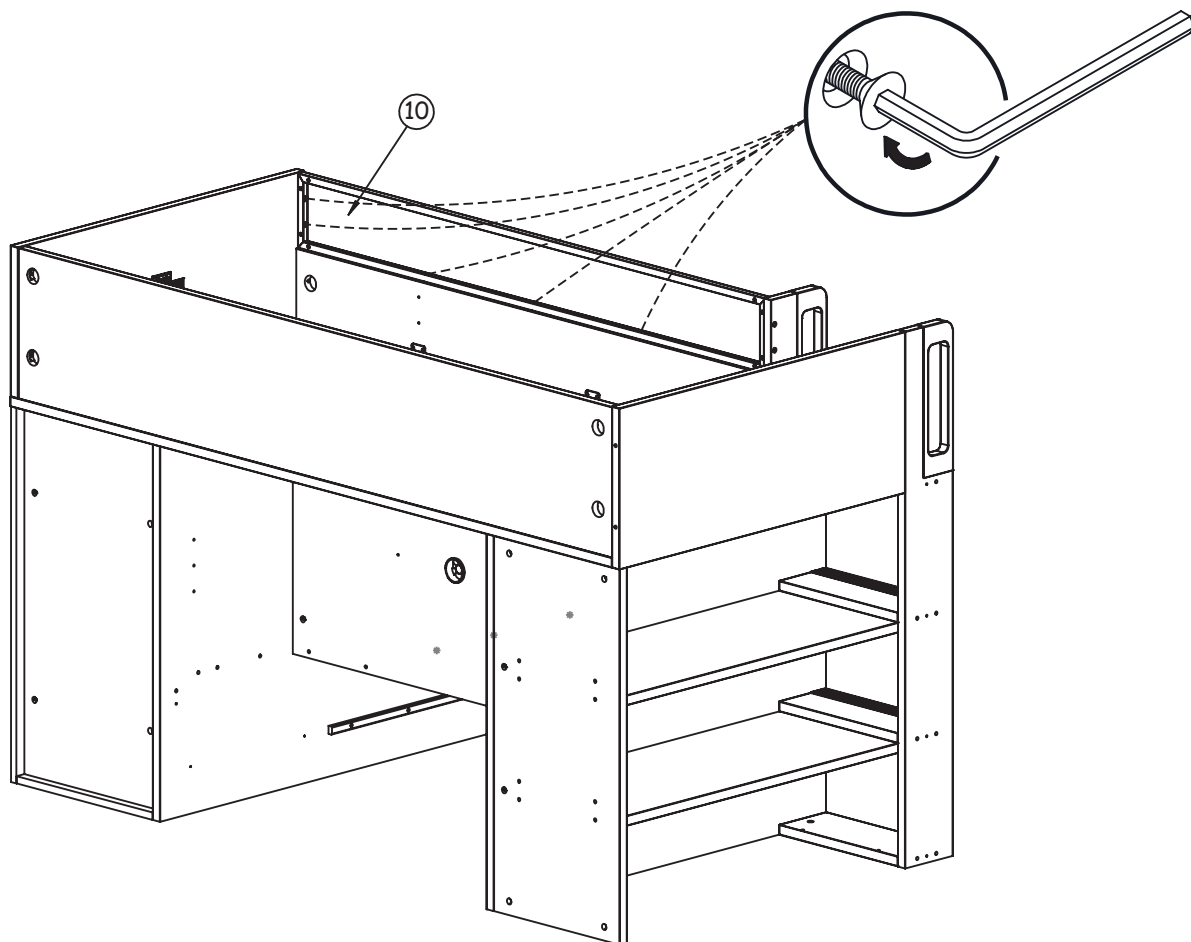
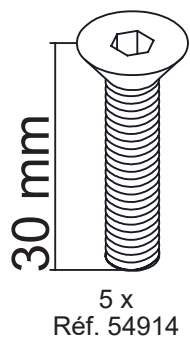

A-49

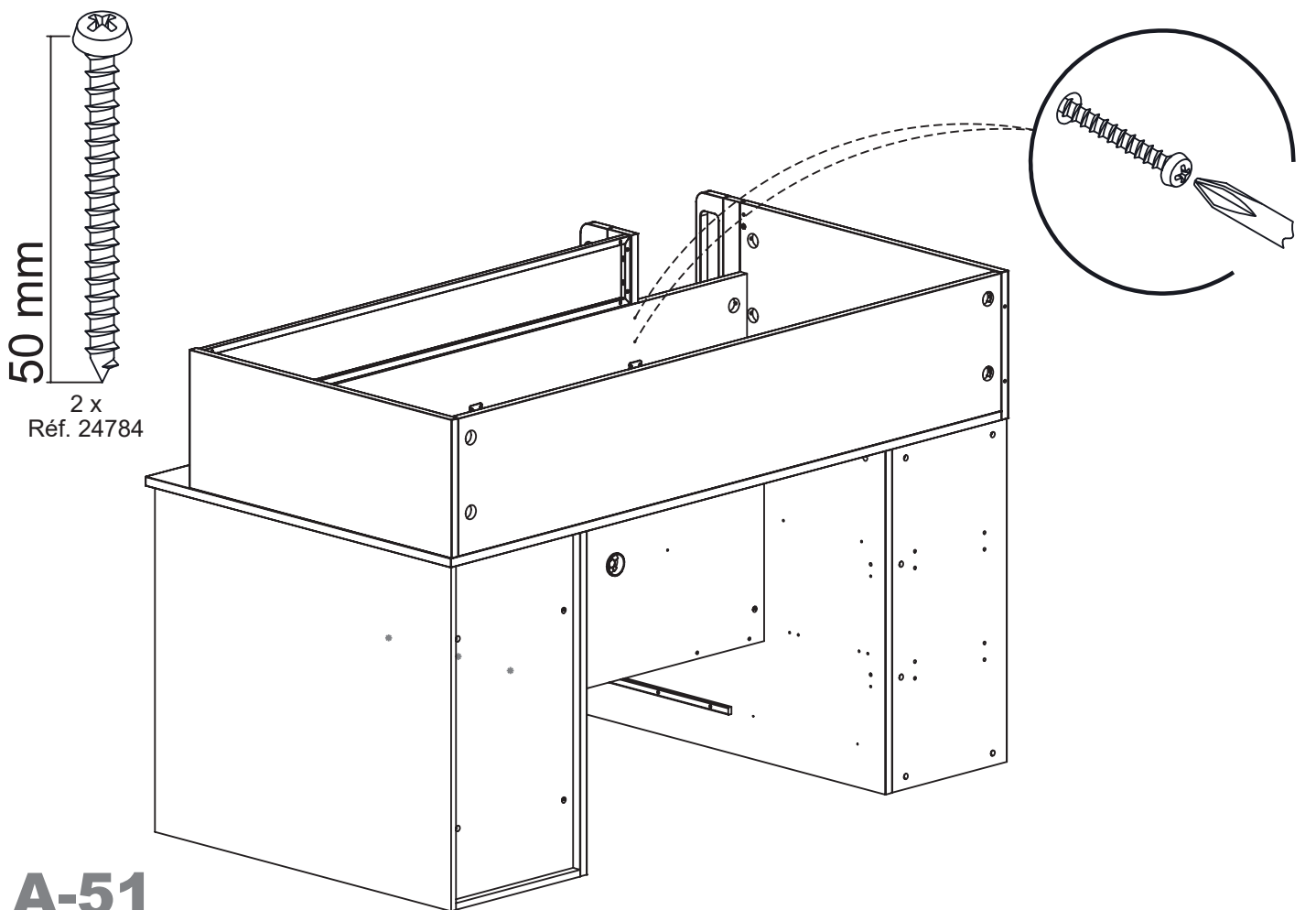
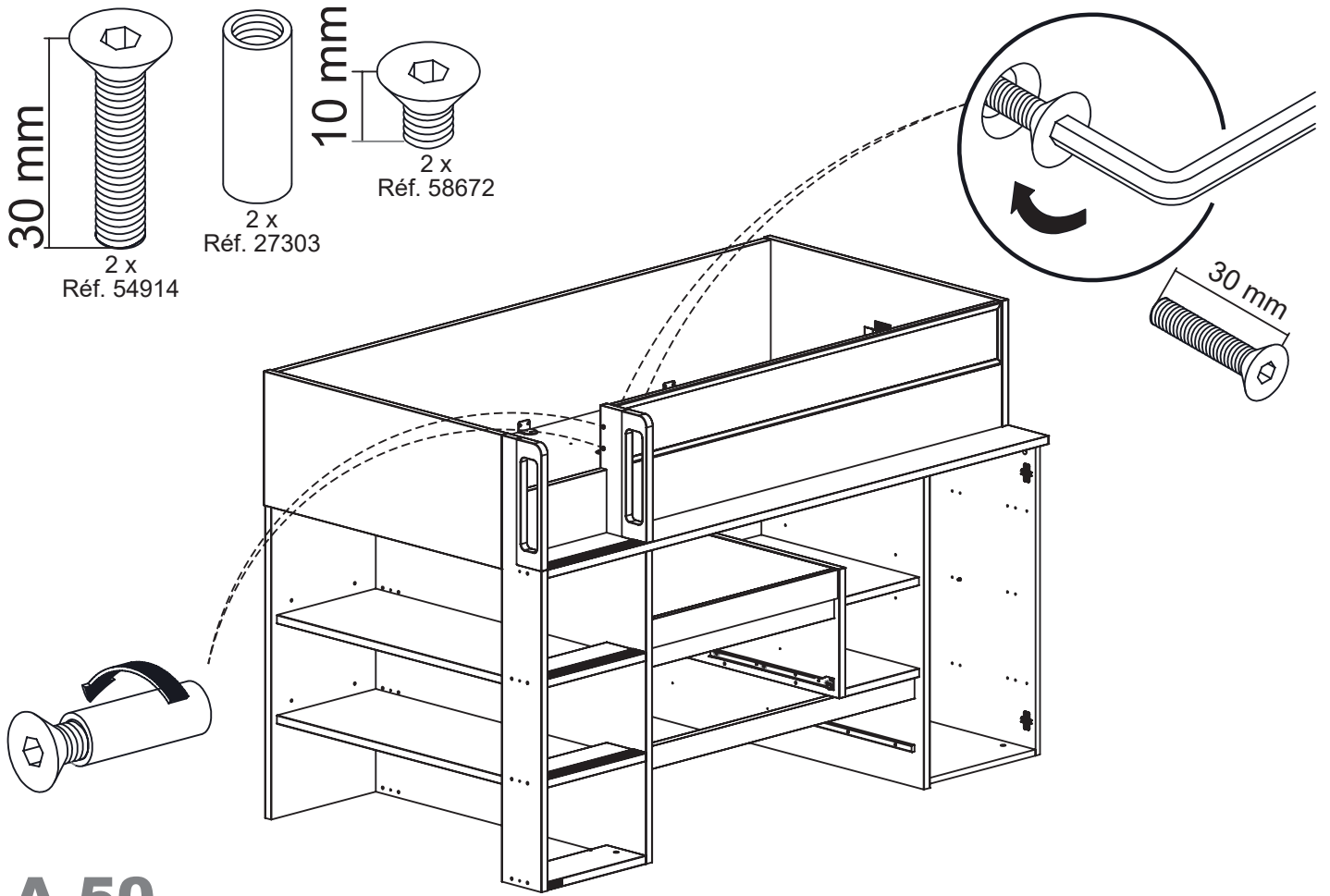

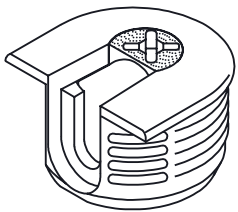

4 x
Réf. 40811

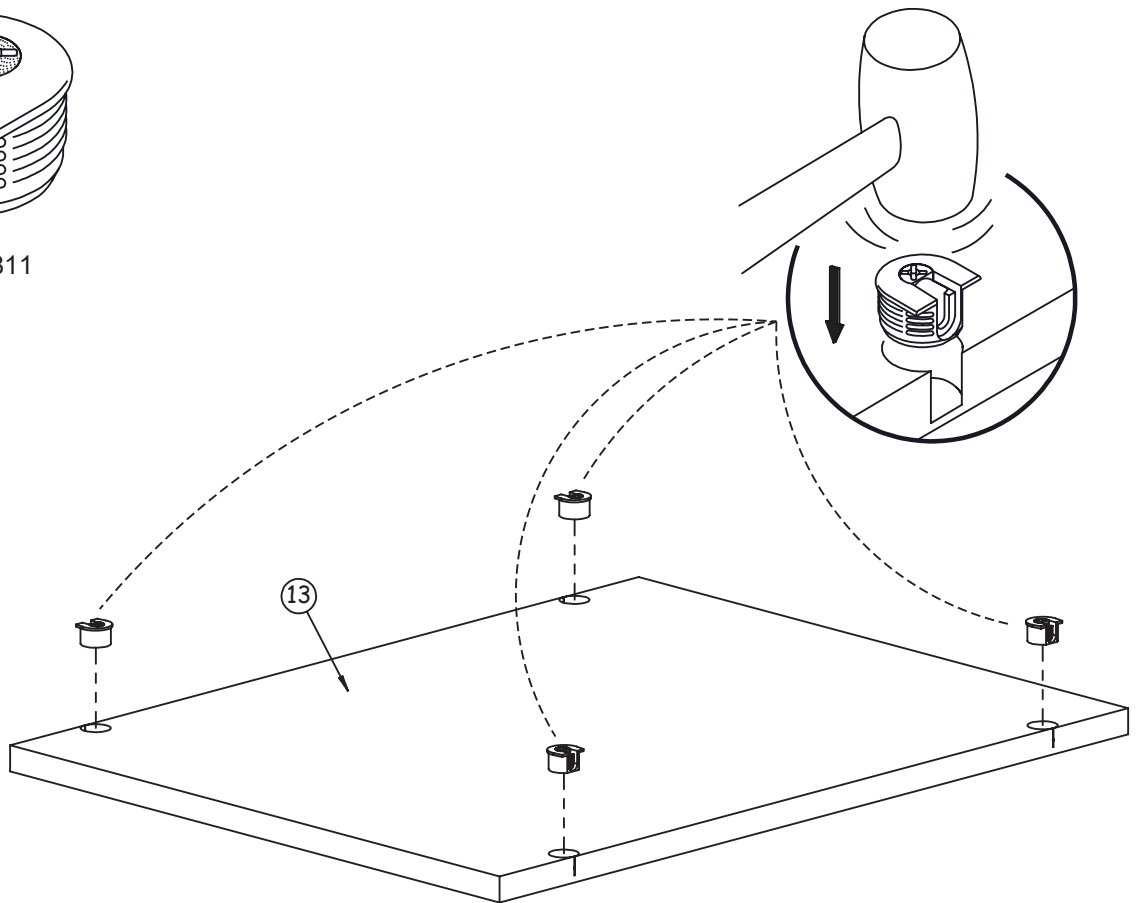

A-52

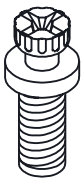

4 x
Réf. 40812

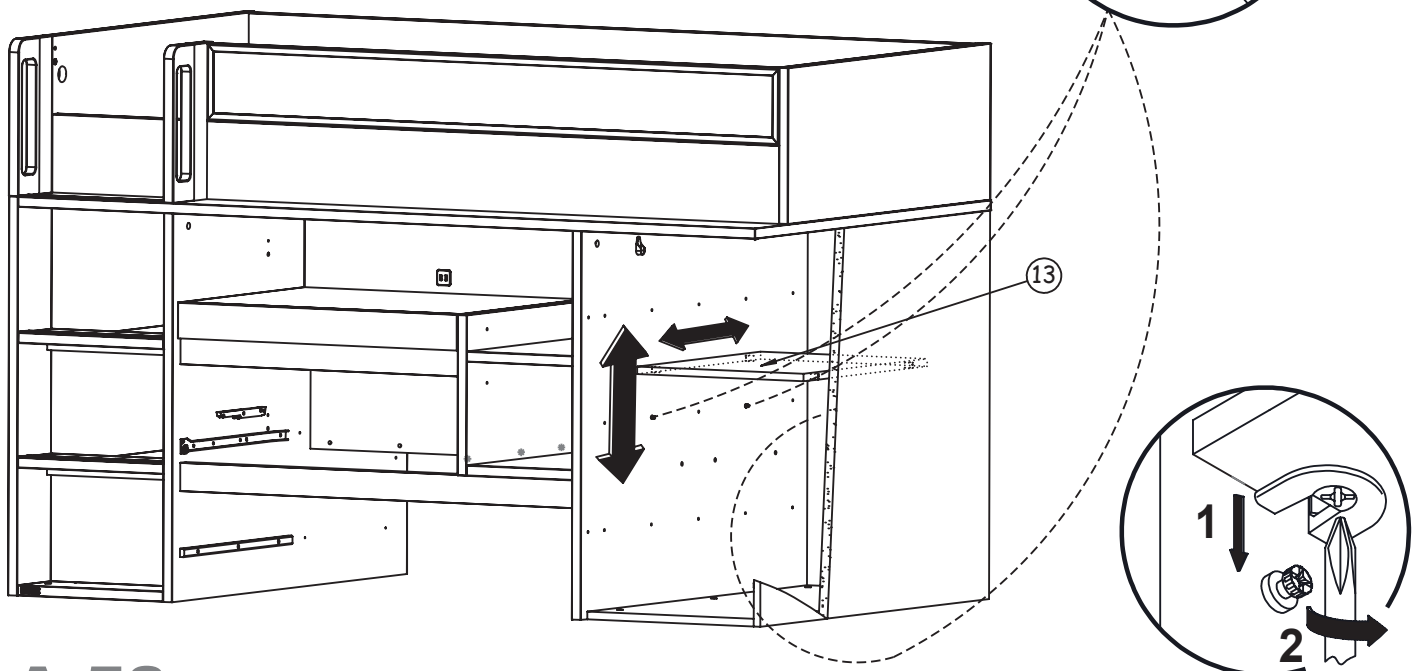

A-53

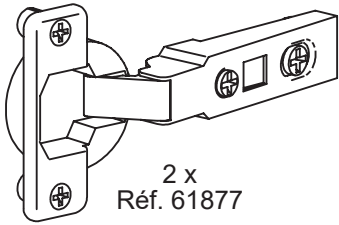

2 x
Réf. 61877

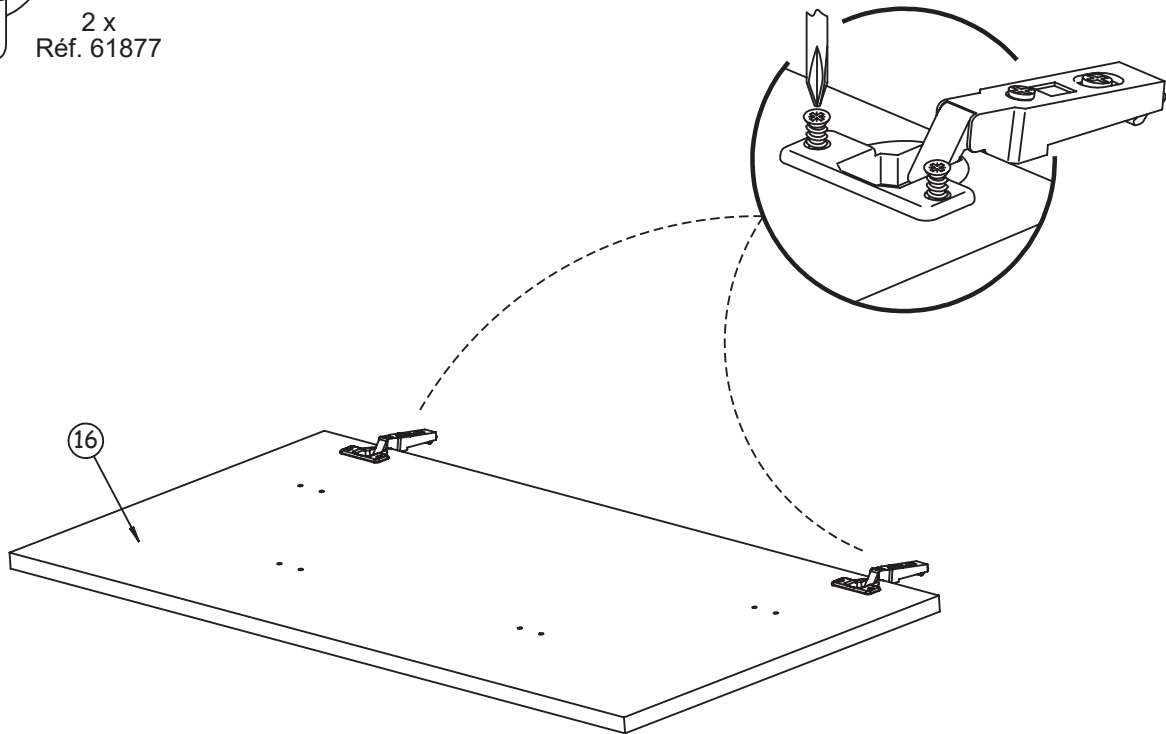

A-54

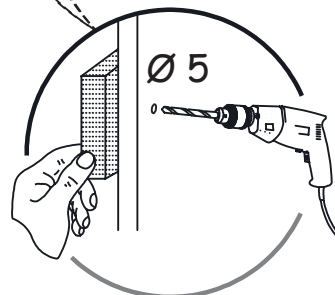
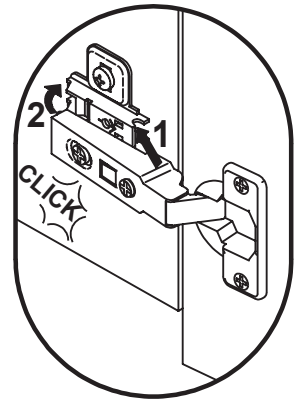
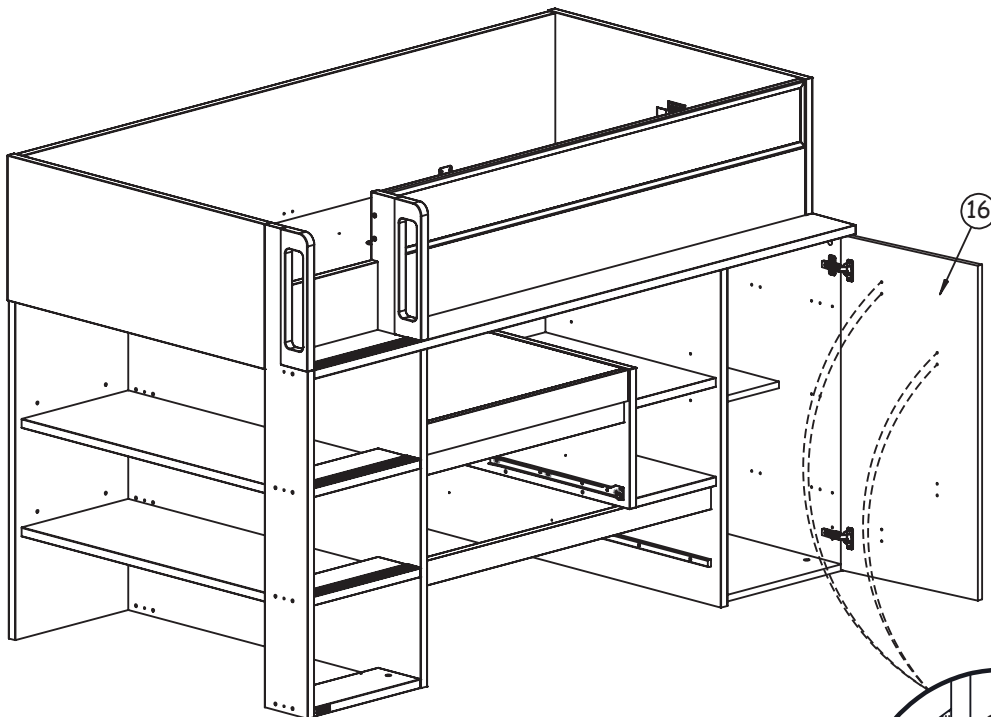

Pour éviter les éclats,
utilisez une cale martyr.
To avoid any splinter,
use a wood wedge.

A-55

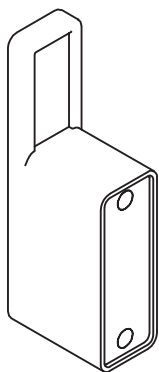

A06-GRIS
2 x Réf. 66651
A26 CHENE
2 x Réf. 66652

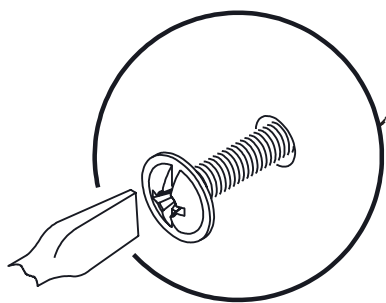
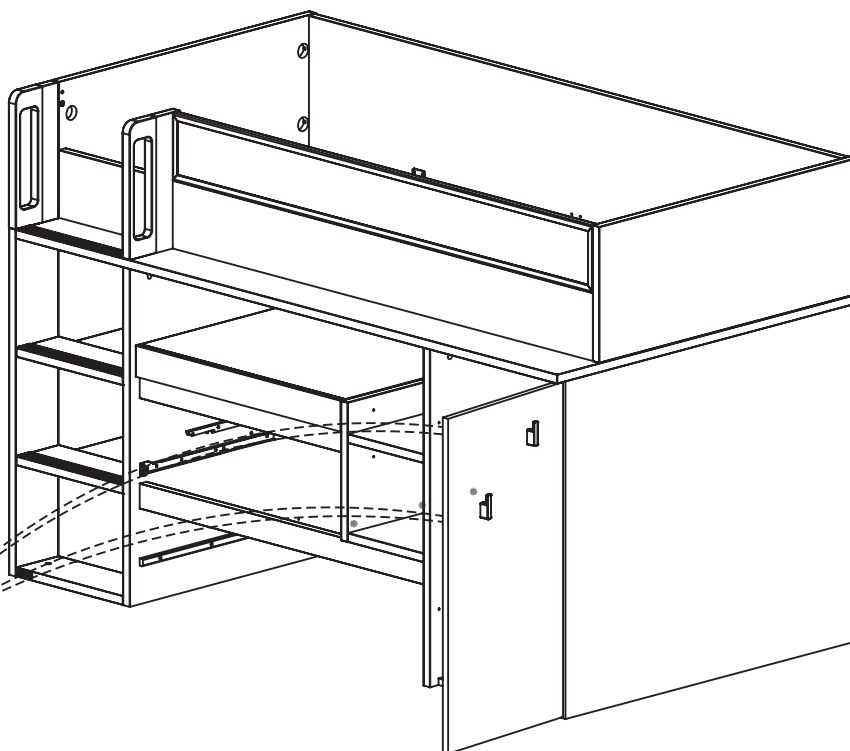

A-56

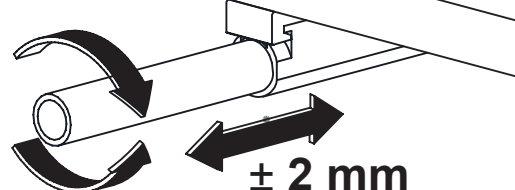
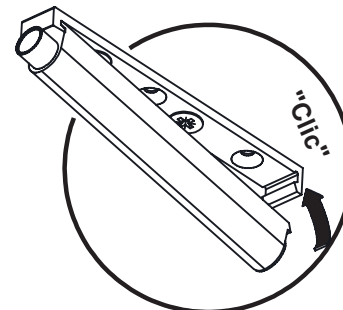
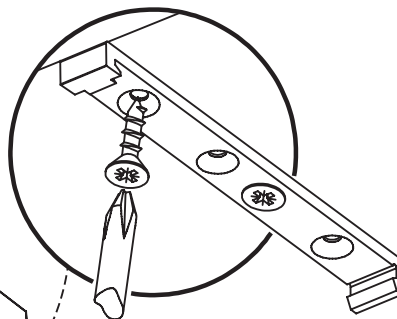
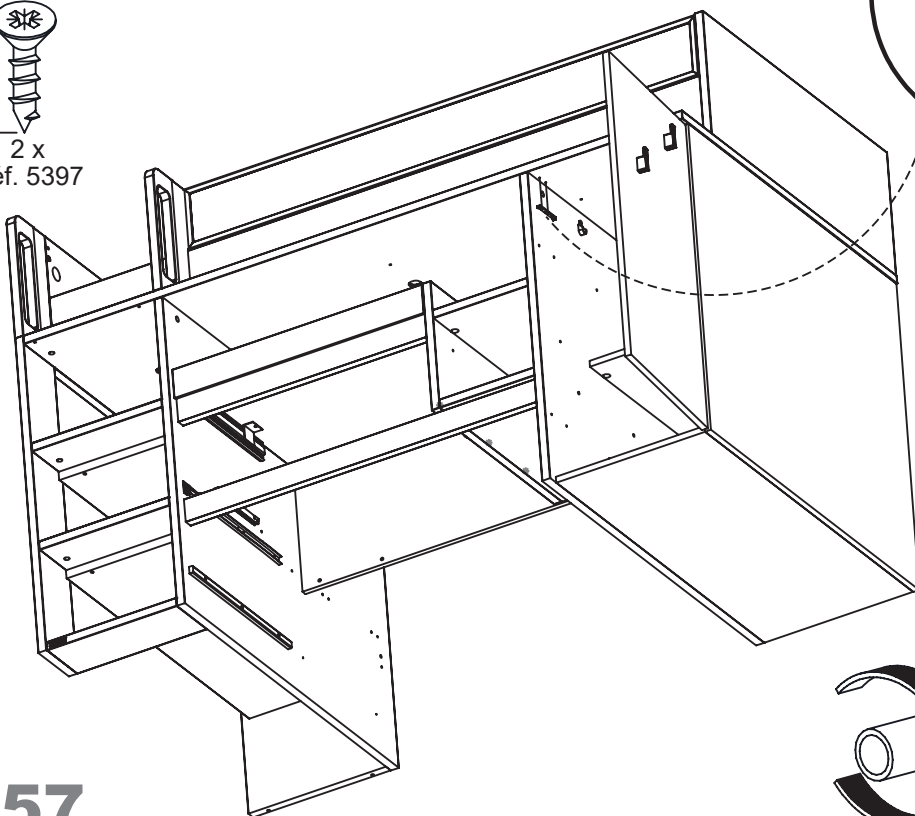
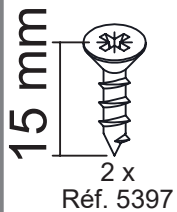
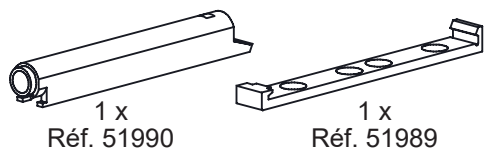

A-57

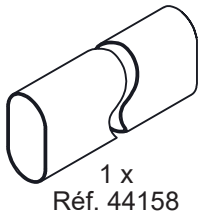

1 x
Réf. 44158

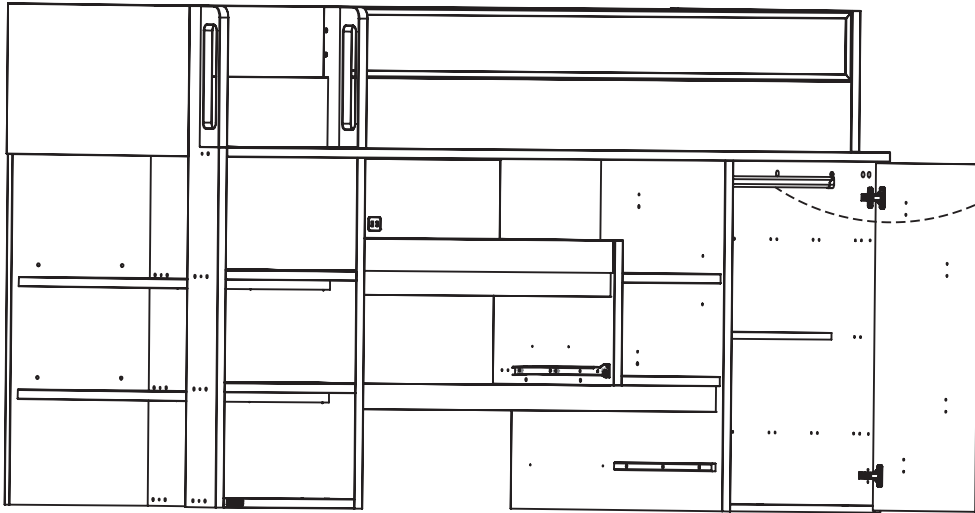
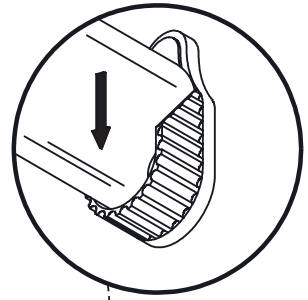

A-58

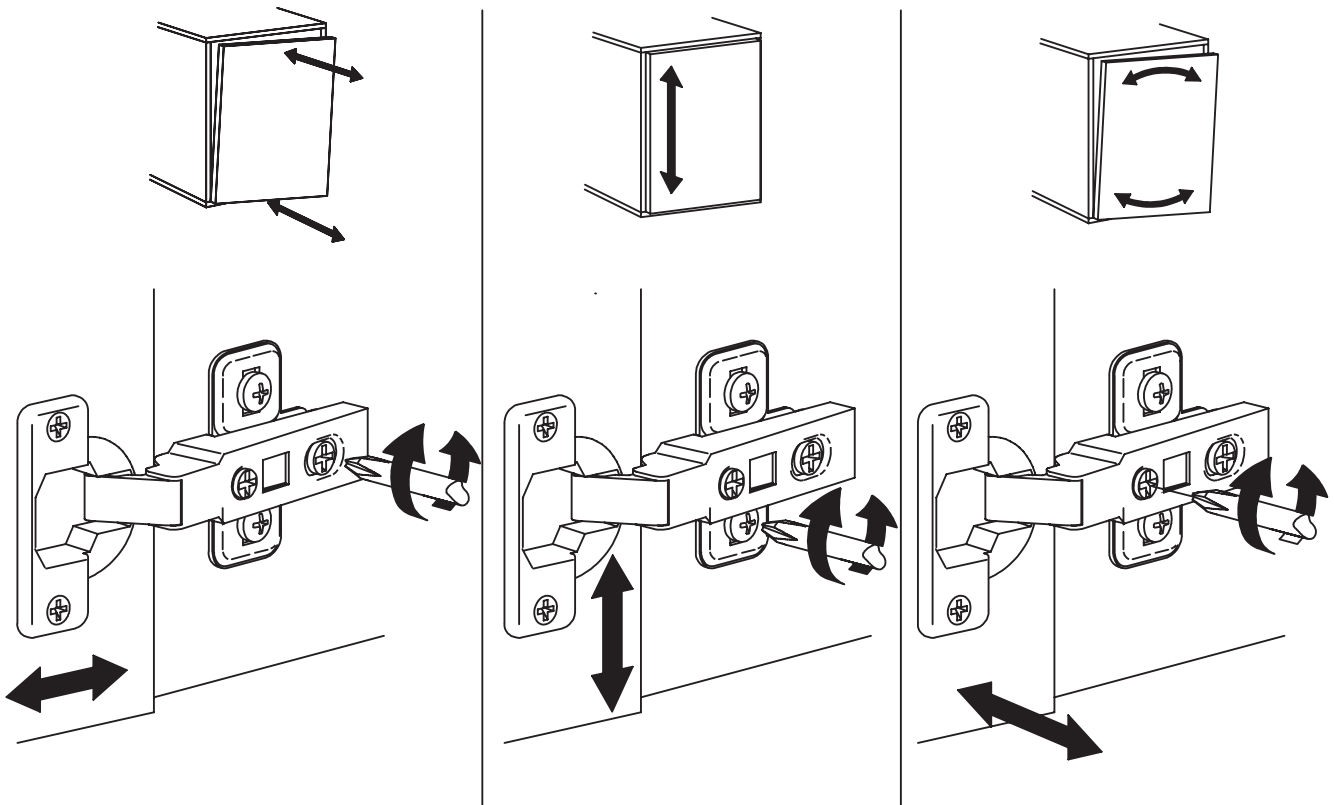

A-59

15 mm
3 x
Réf. 5397

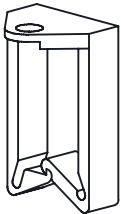

3 x
Réf. 63706

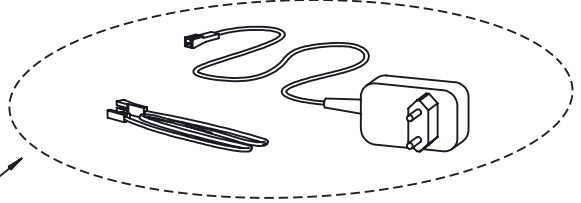
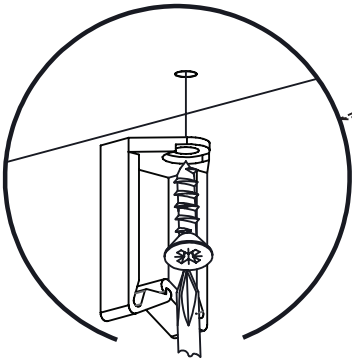
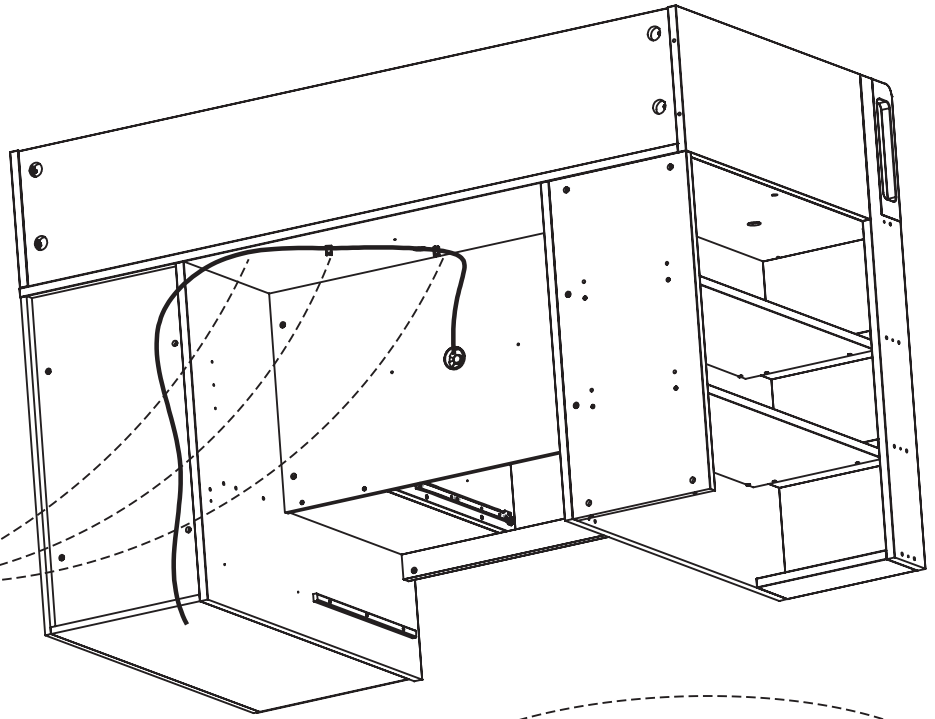

A-60

Branchement du chargeur

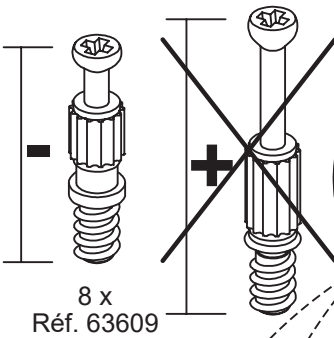

8 x
Réf. 63609

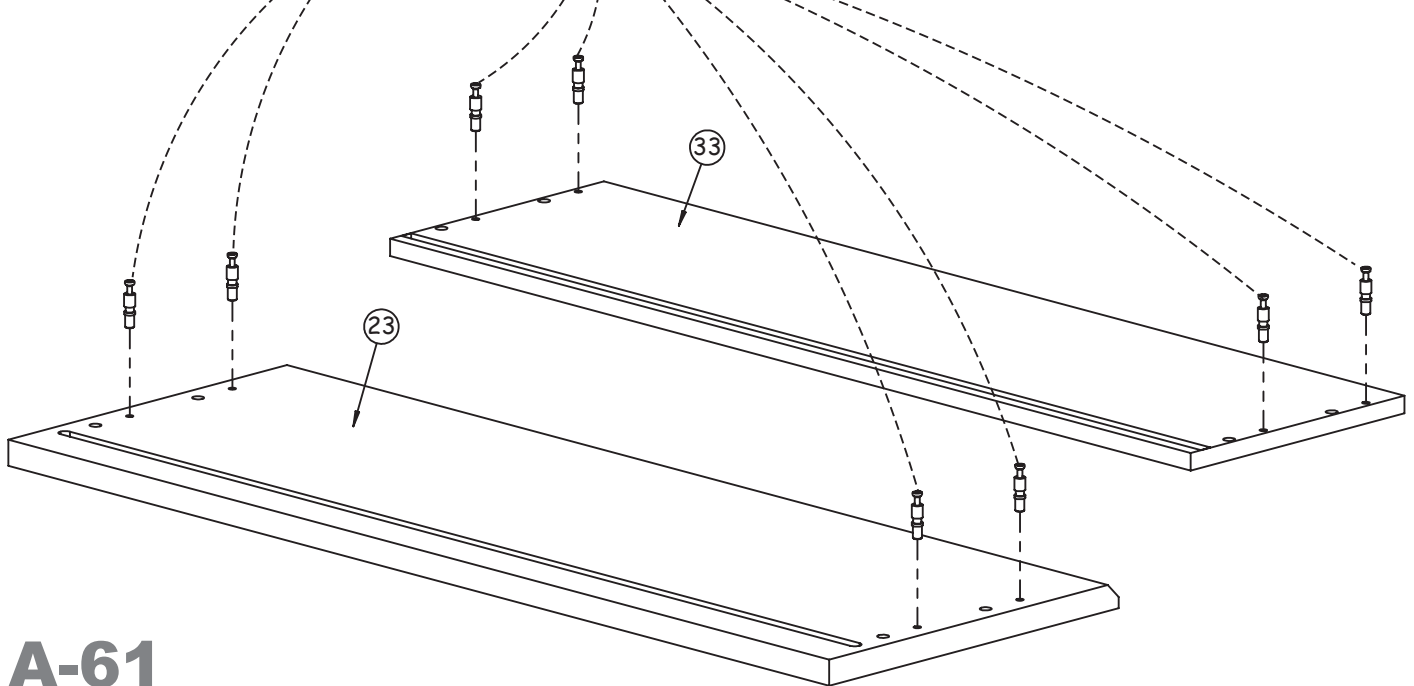
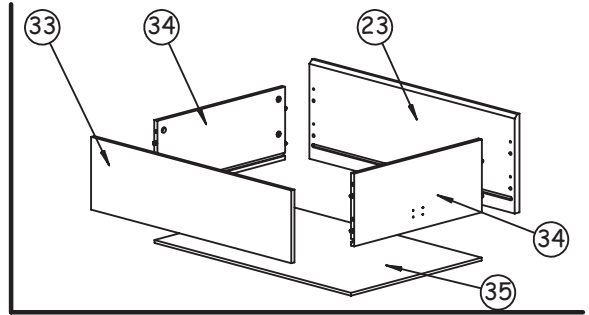
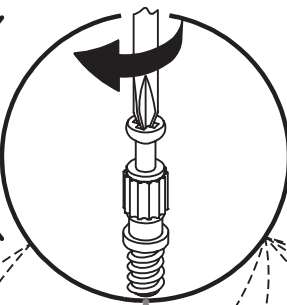

A-61

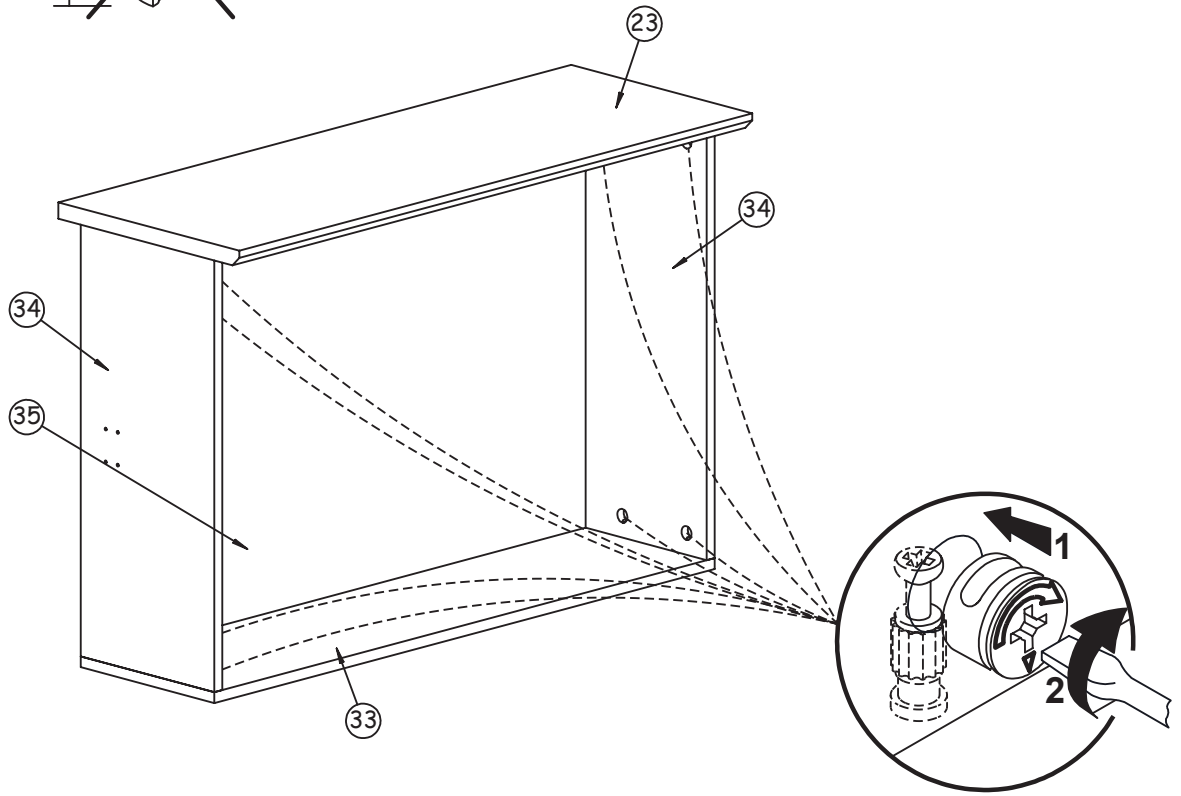
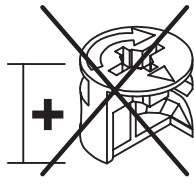
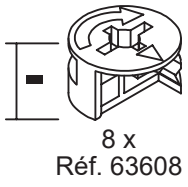

A-62

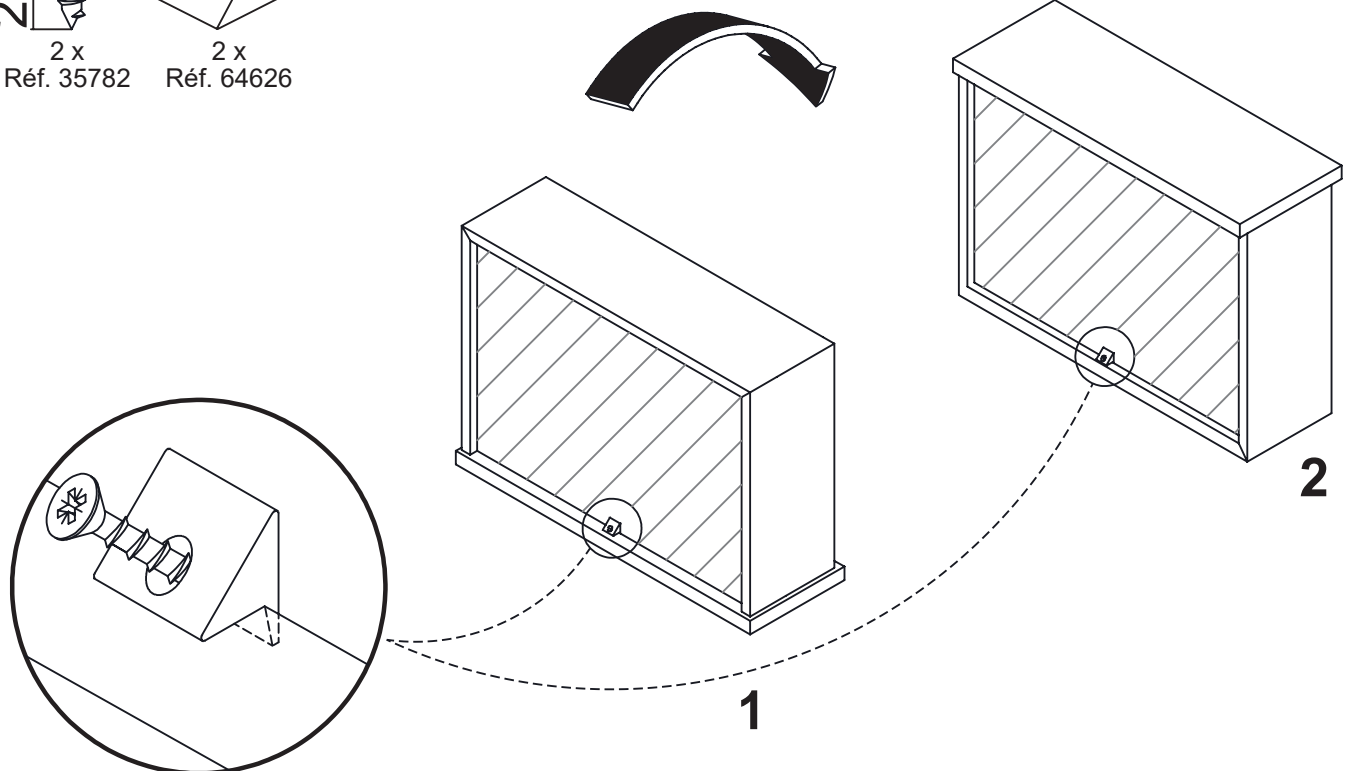
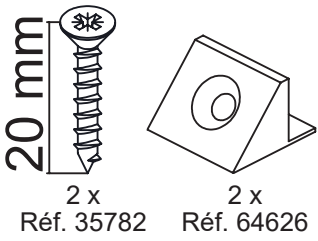

A-63

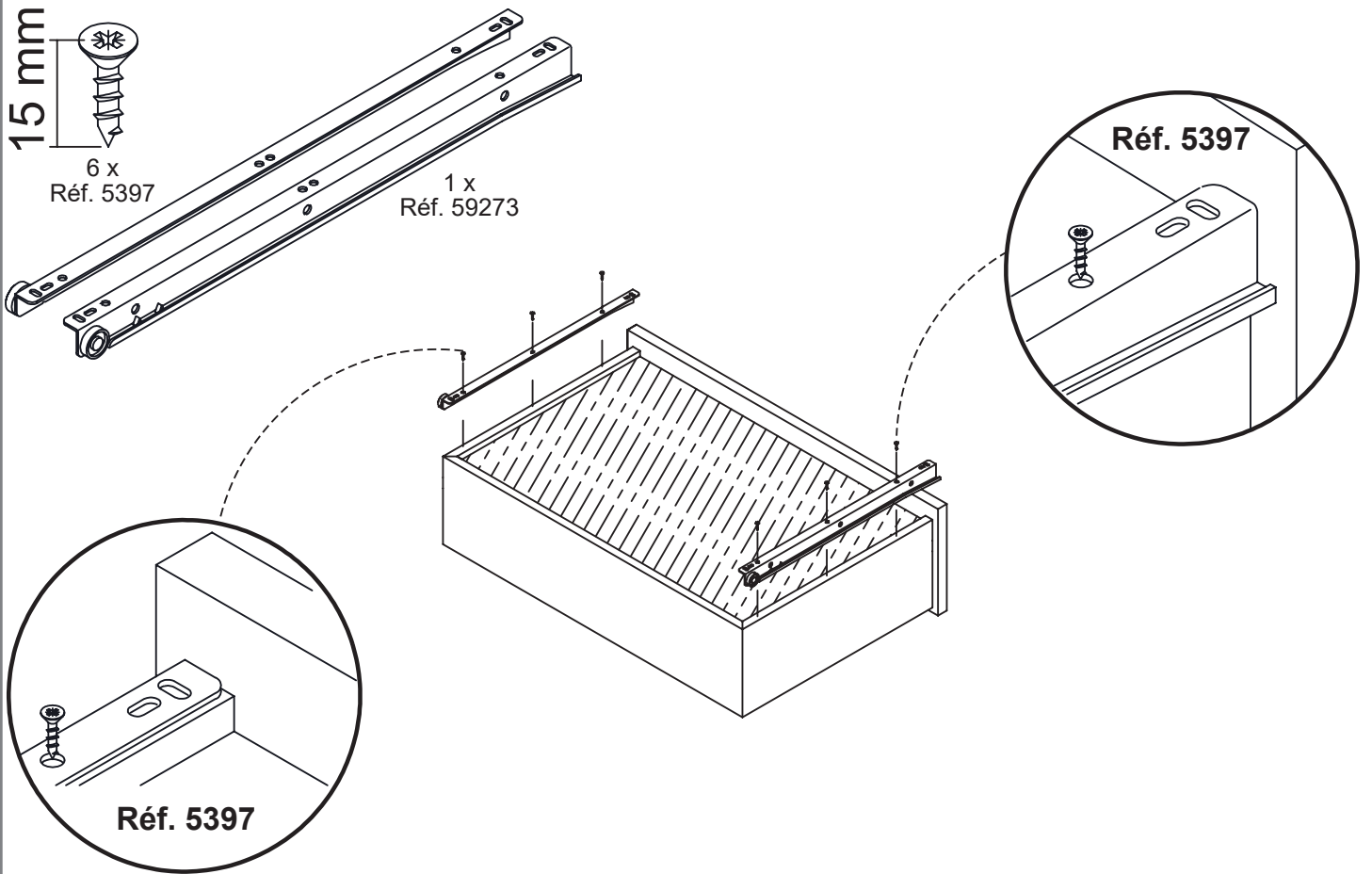

A-64

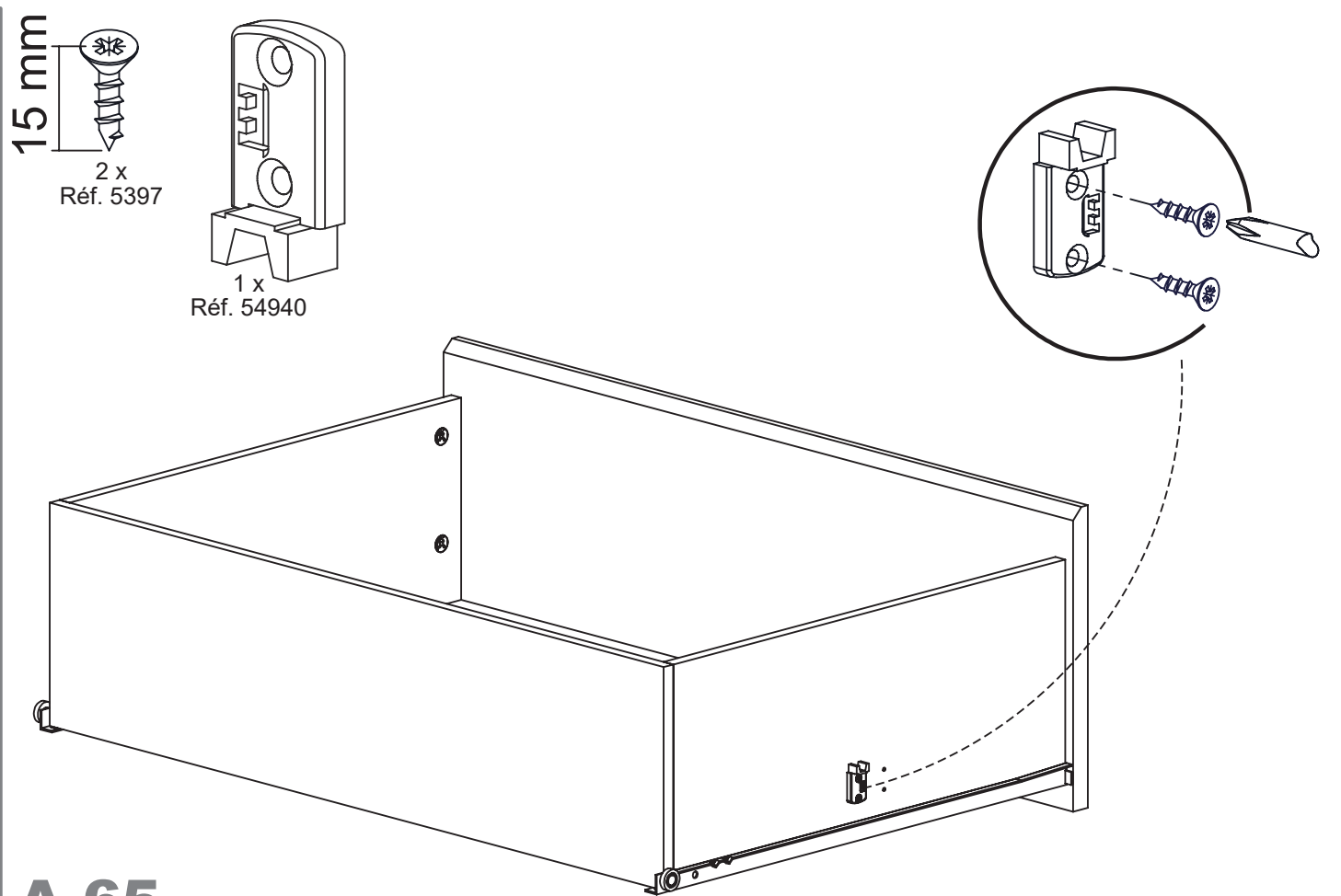

A-65

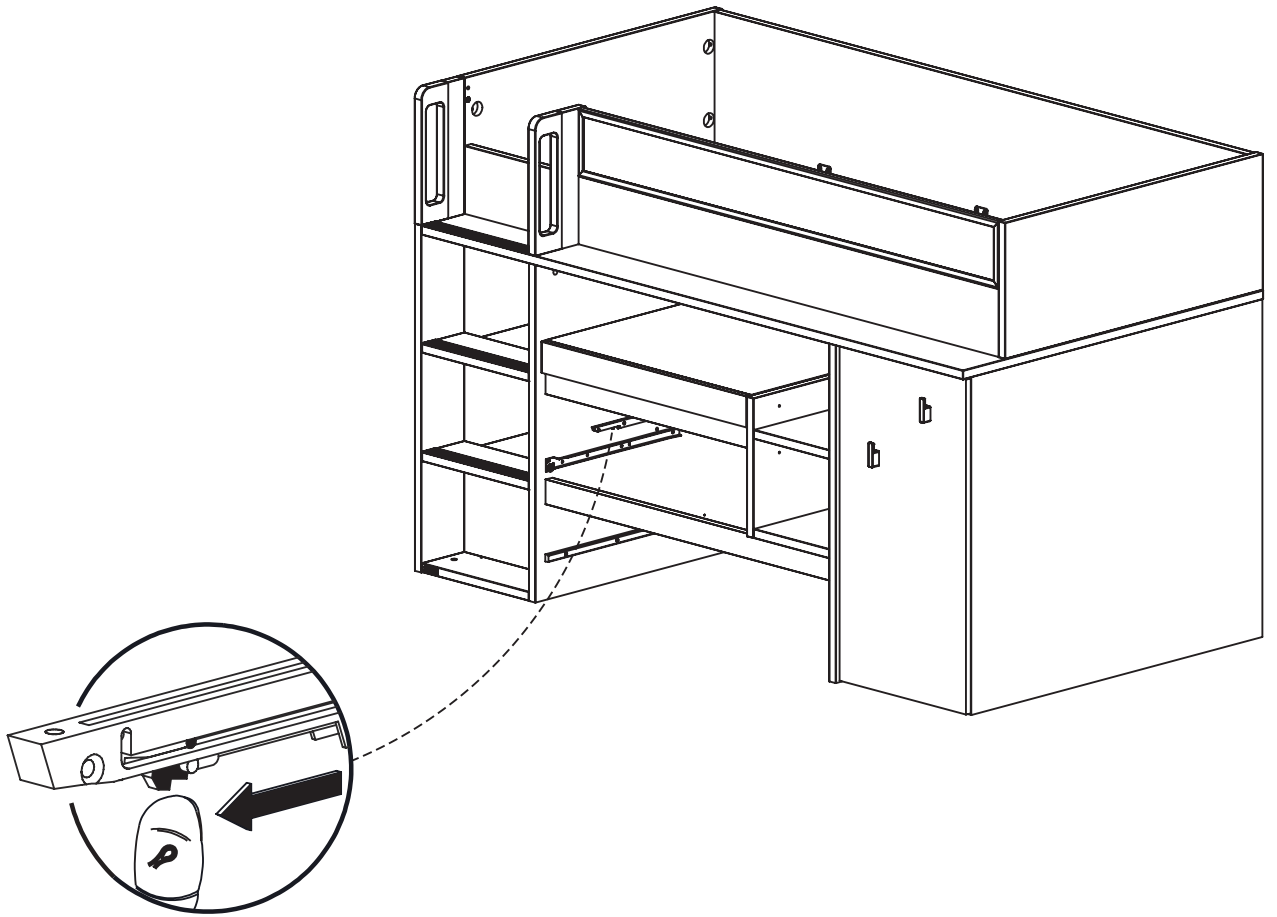

A-66

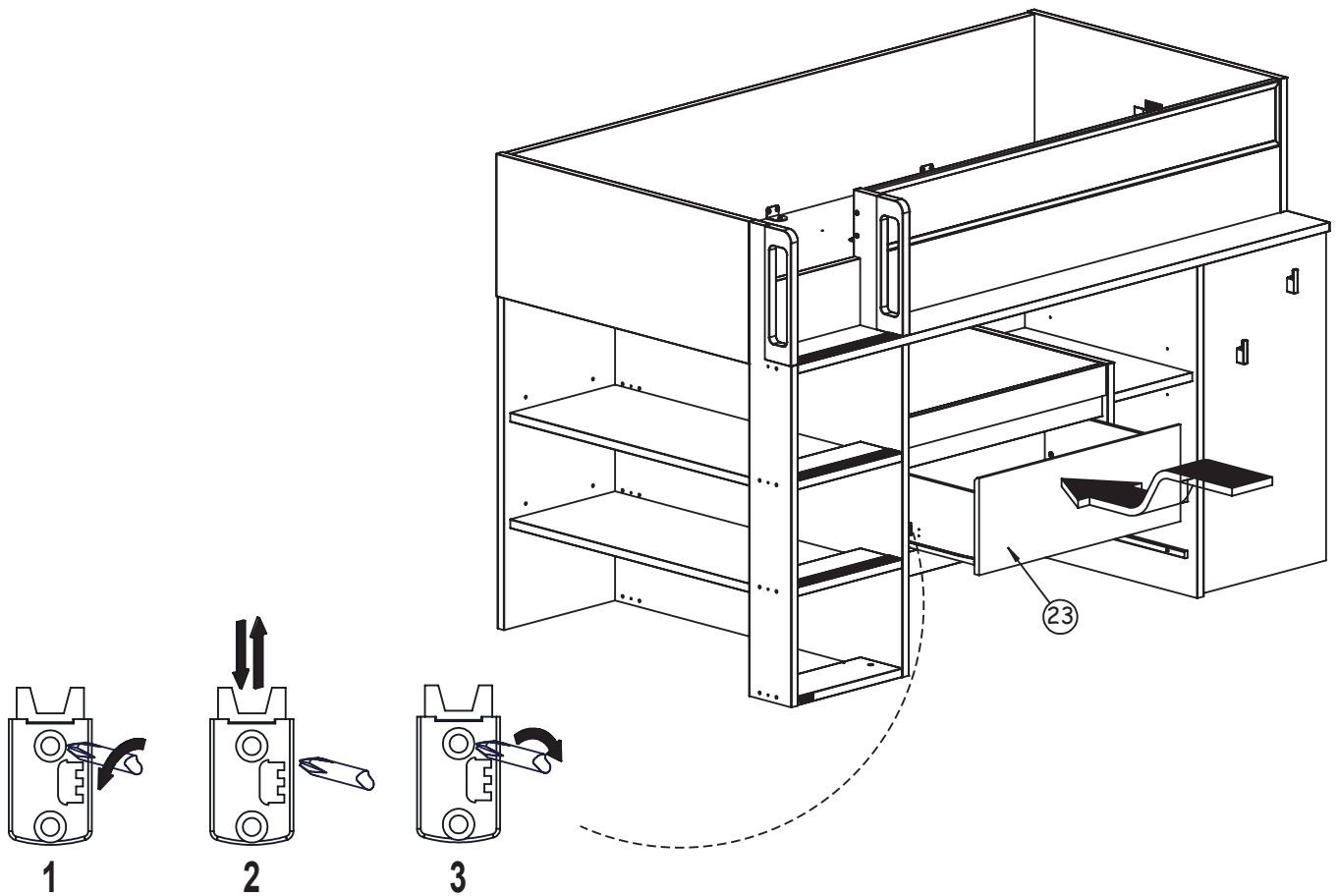

A-67

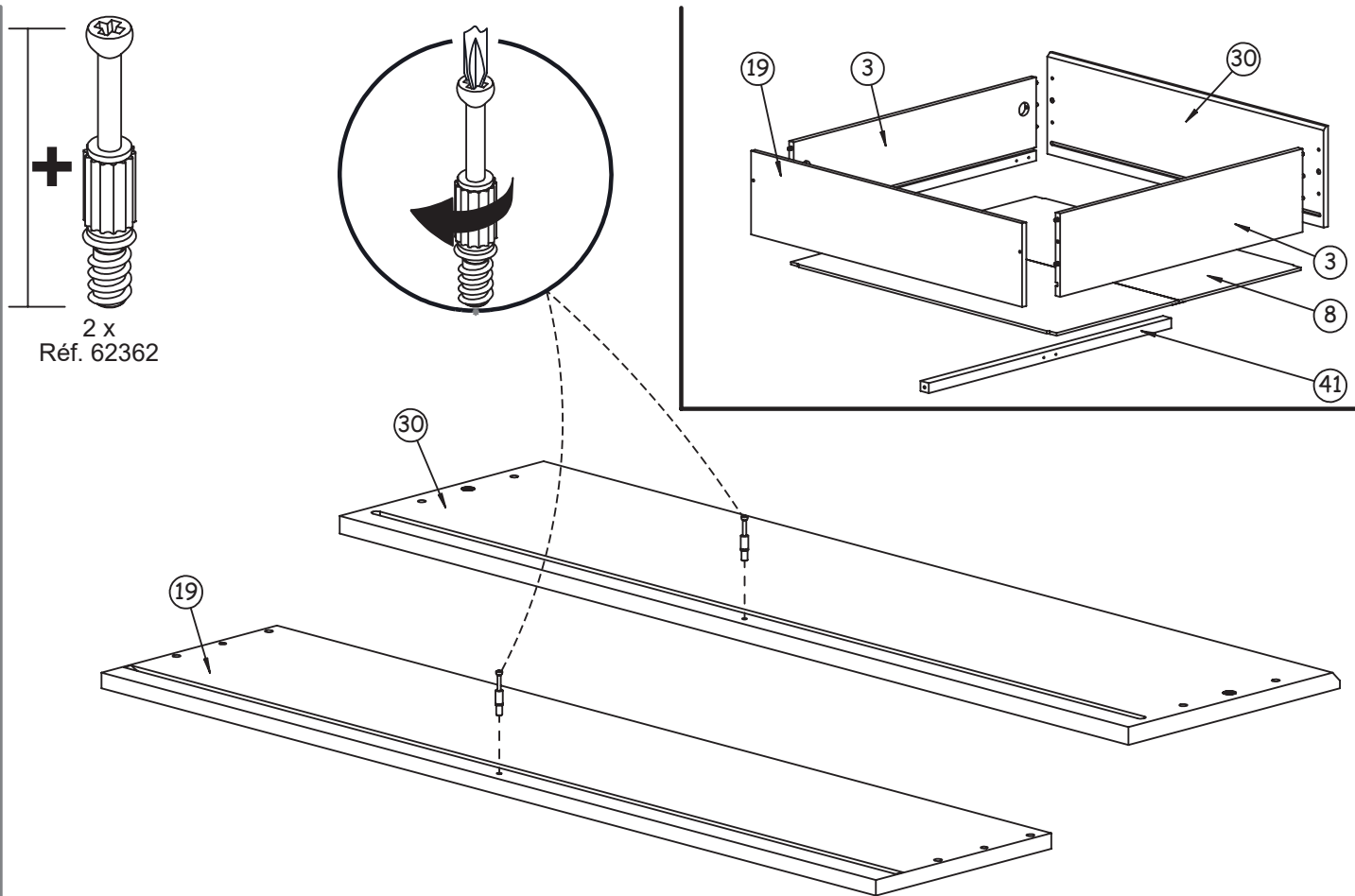

A-68

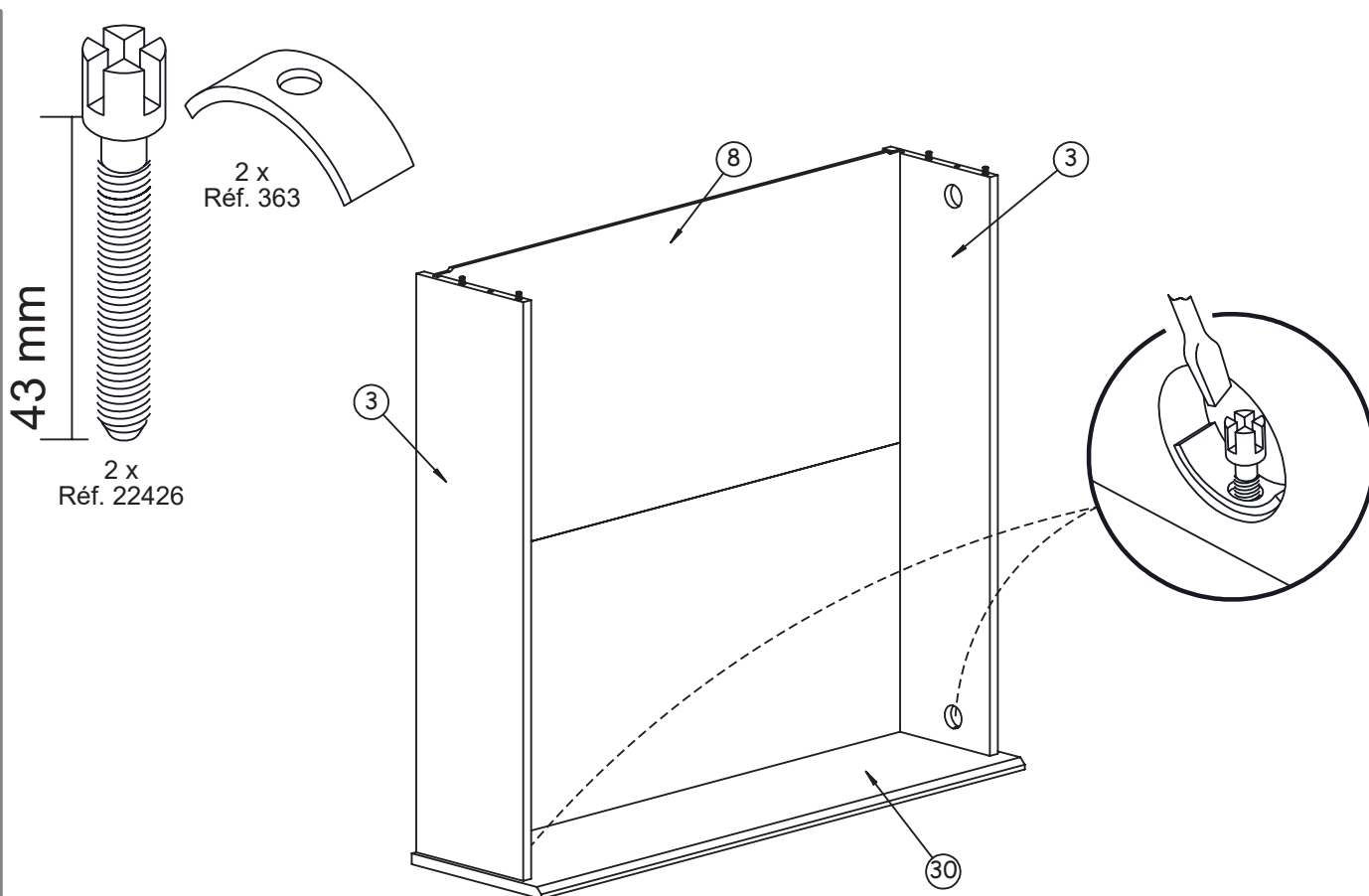

A-69

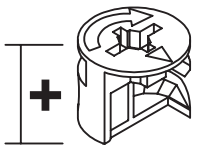

1 x
Réf. 62370

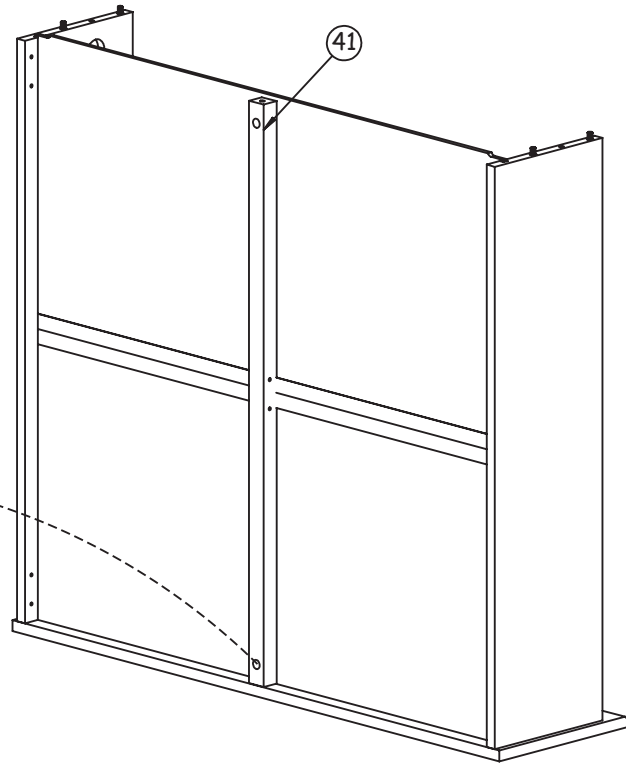

A-70

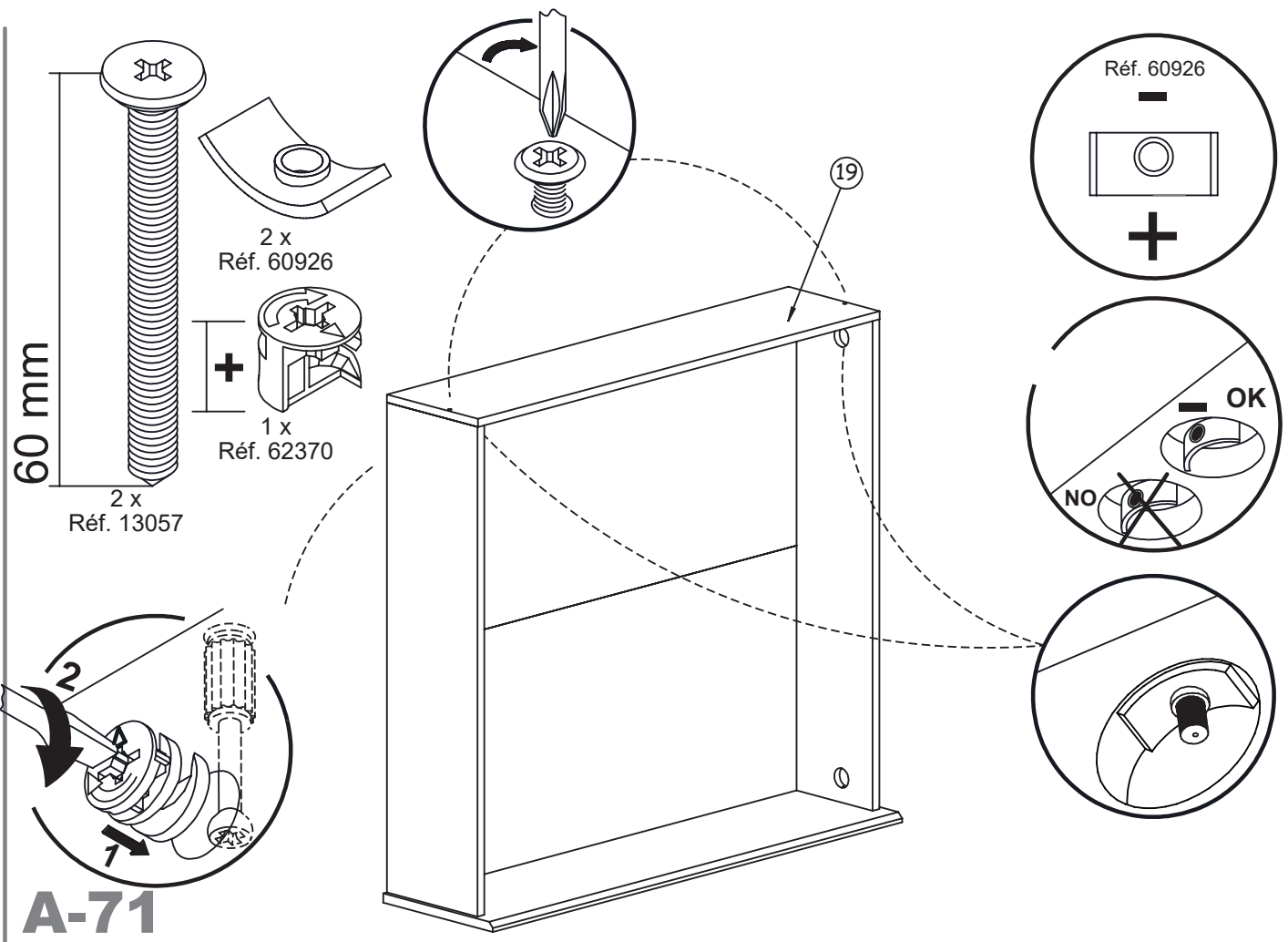

A-71

14 mm
10 x
Réf. 7874

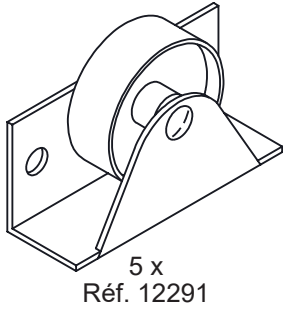

A06-BLANC
2 x Réf. 12805
A26-CHENE
2 x Réf. 60749

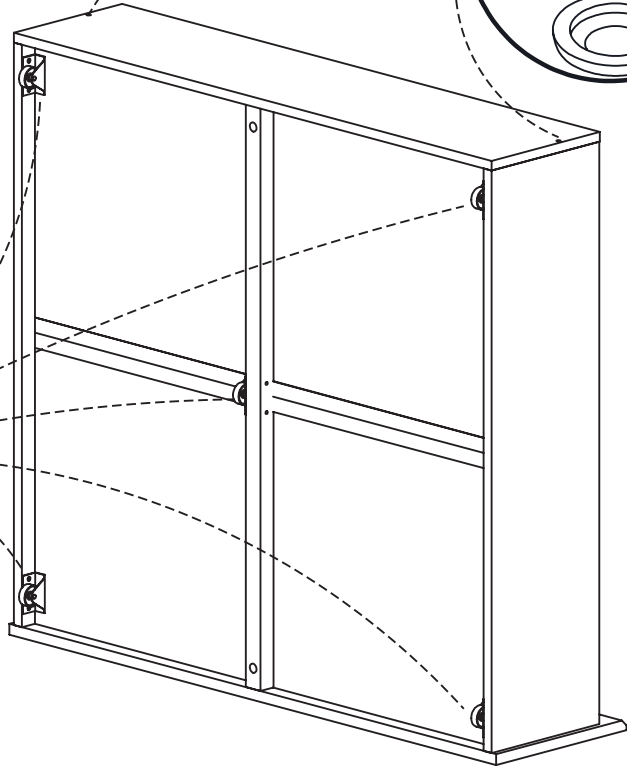
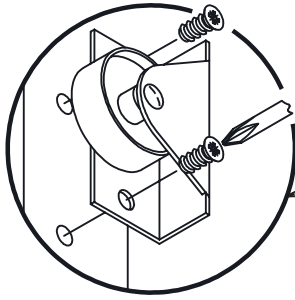
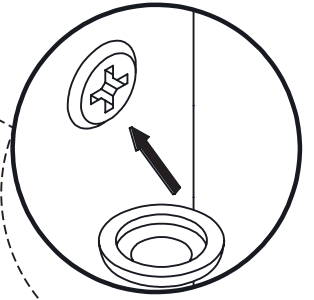

A-72

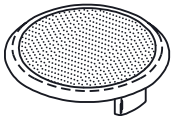

A06-BLANC
4 x Réf. 15118
A06-GRIS
10 x Réf. 58624
A26-CHENE
14 x Réf. 66502

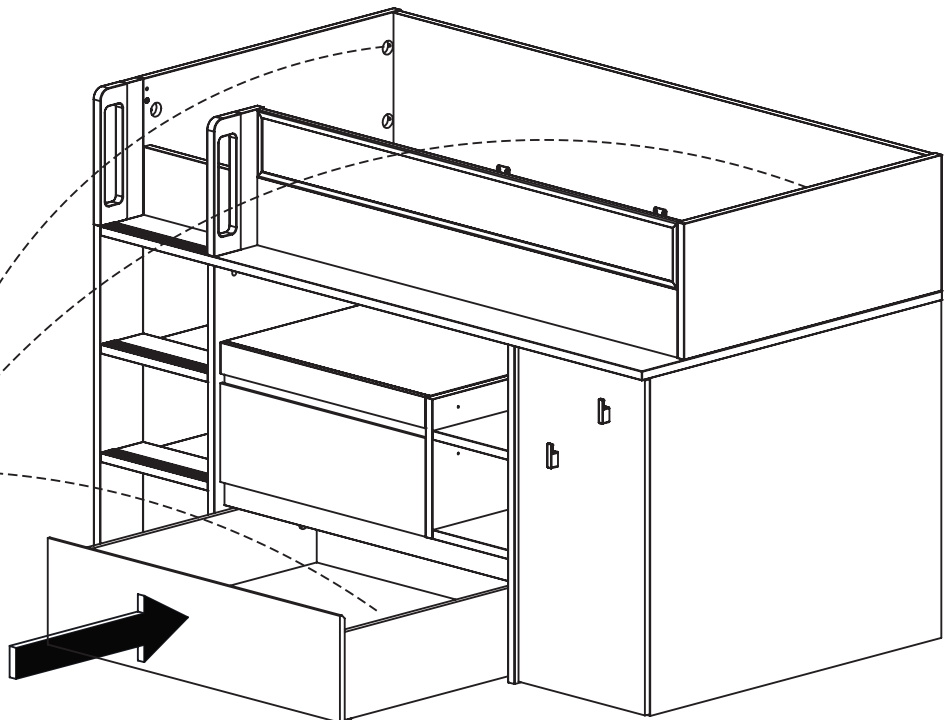
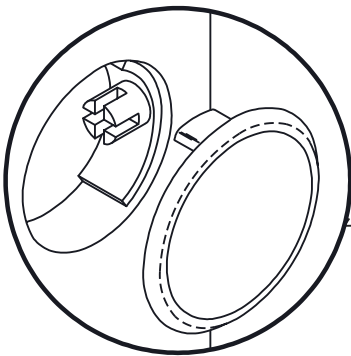

A-73



A06-GRIS
18 x Réf. 58621
A06-BLANC
4 x Réf. 9361

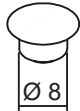

A06-GRIS
28 x Réf. 58626



A26 CHENE
4 x Réf. 66077

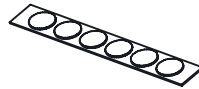

A06-GRIS
4 x Réf. 63760
A06-BLANC
4 x Réf. 60162
A26 CHENE
13 x Réf. 62386

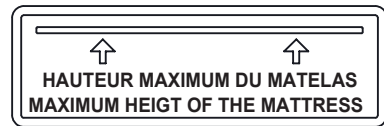

NF EN 747-1 / 2012 + A1:2015
LE COUCHAGE EN HAUTEUR NE CONVIENT PAS A DES
ENFANTS DE MOINS DE 6 ANS
ALL HIGH SLEEPERS ARE NOT RECOMMENDED
FOR CHILDREN UNDER THE AGE OF 6 YEARS

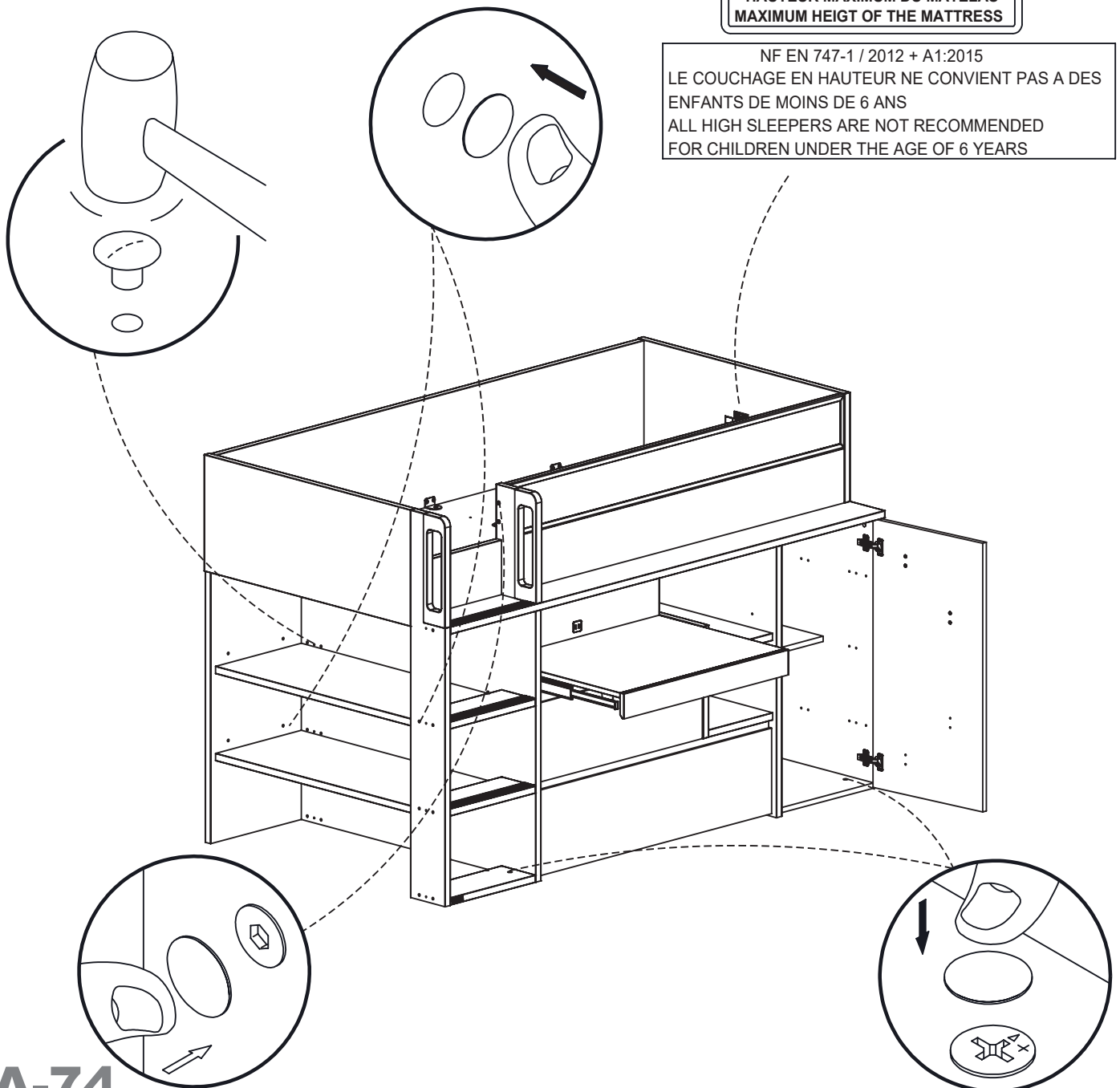

A-74

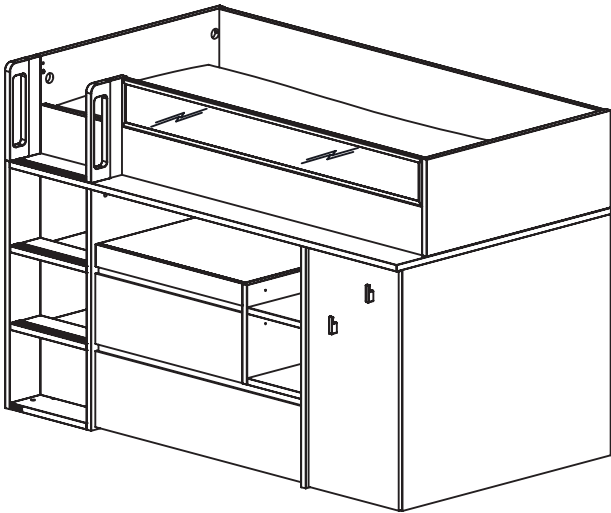
A

P8 → P45

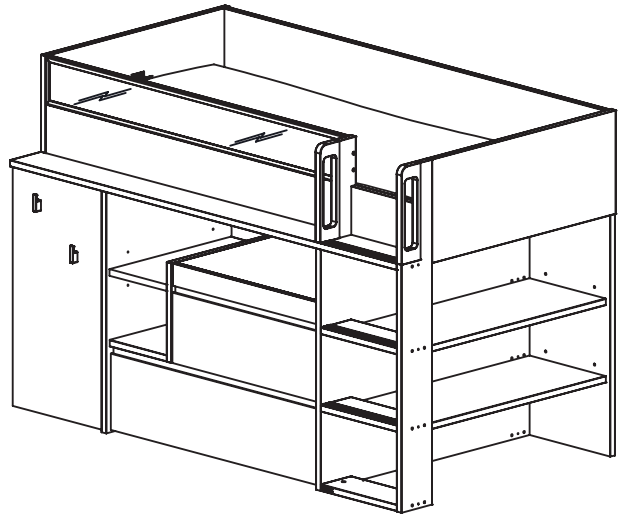
B

P46 → P83

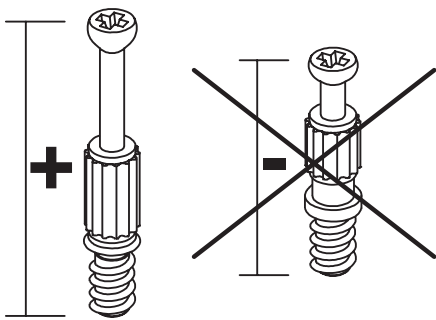

3 x
Réf. 62363

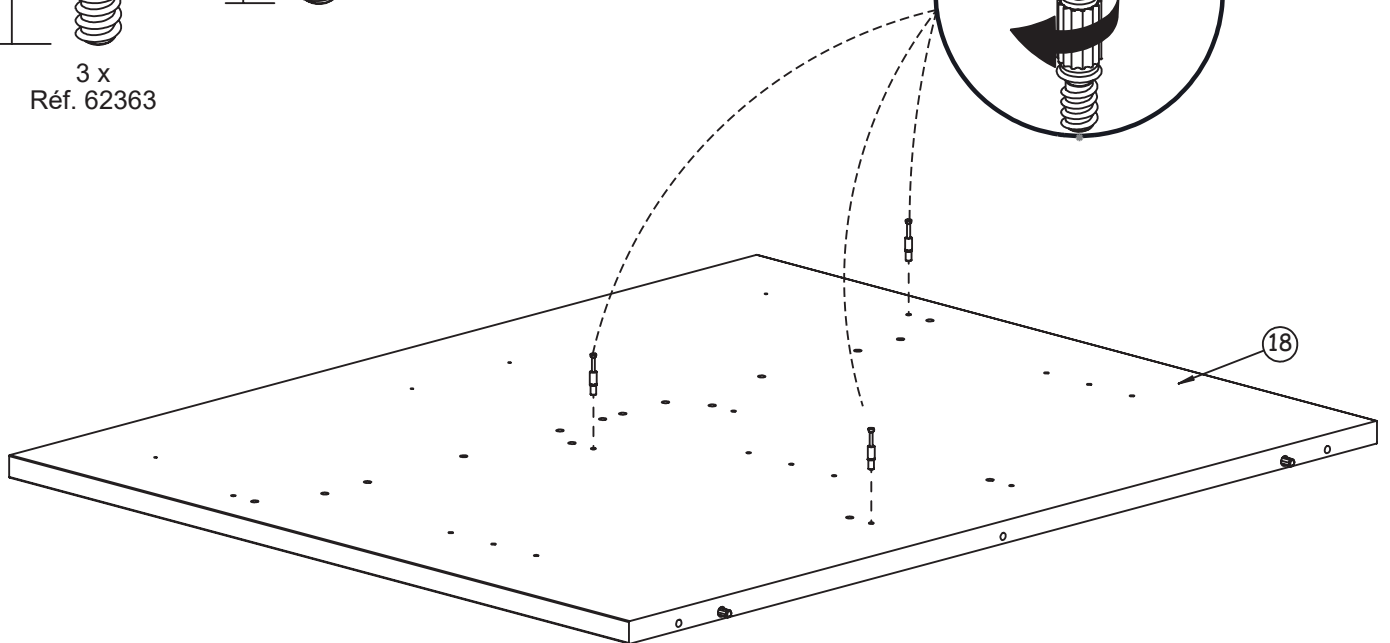
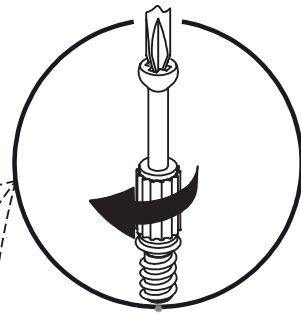
**B-1**

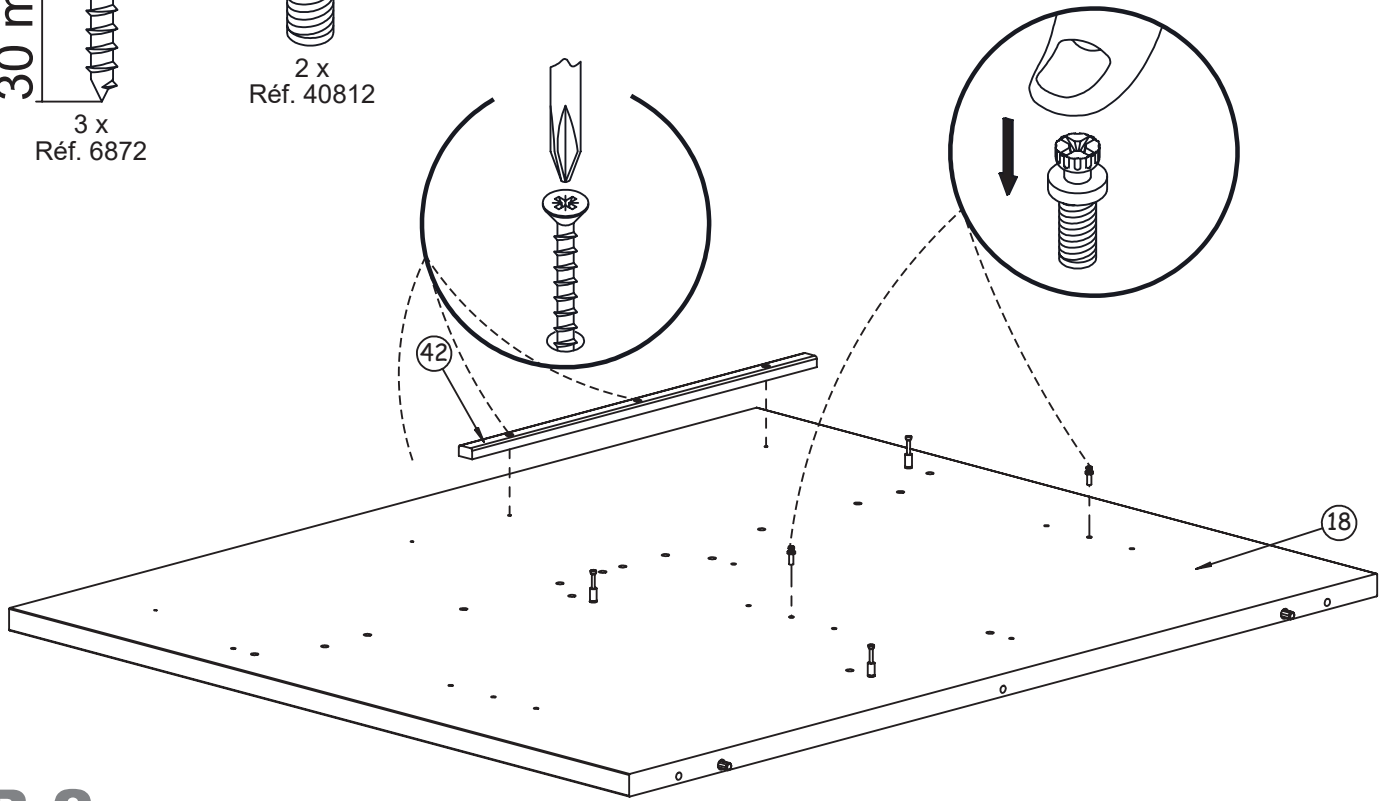
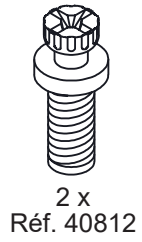
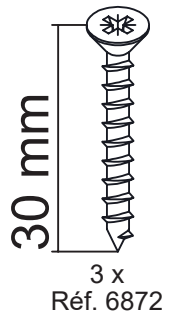

B-2

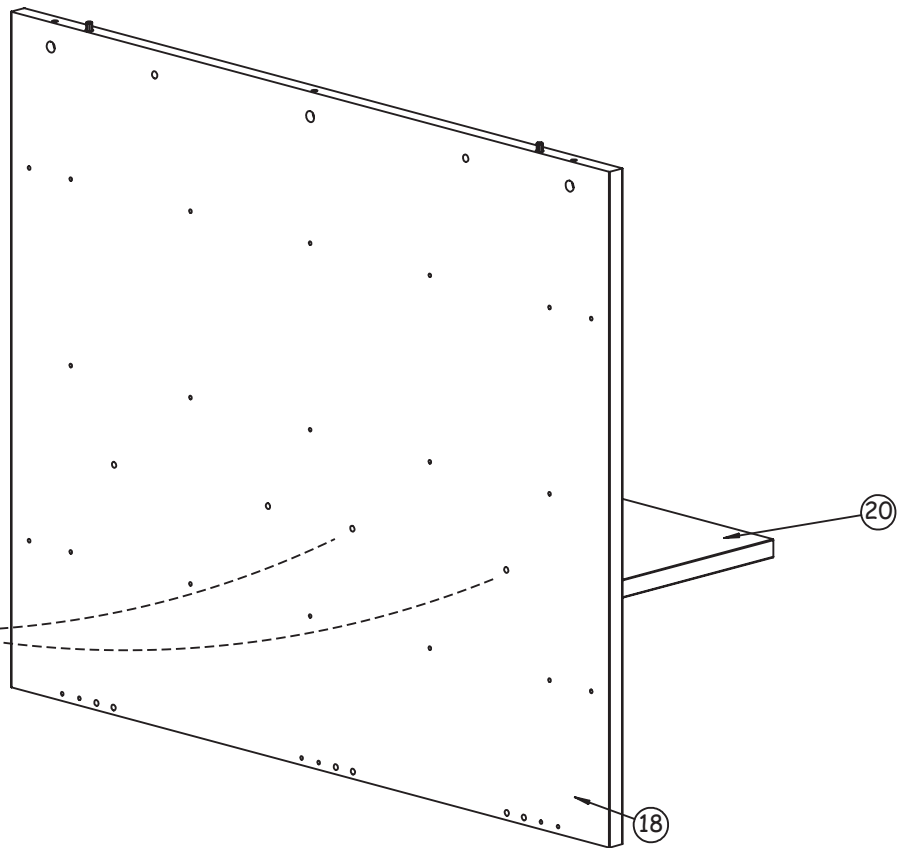
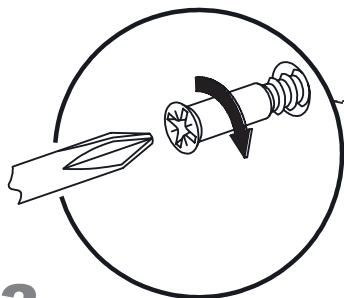
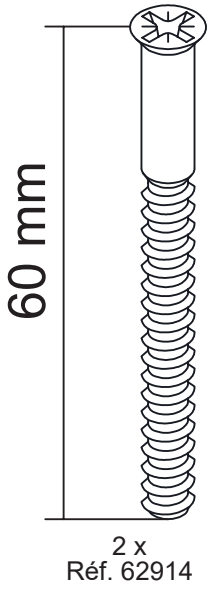

B-3

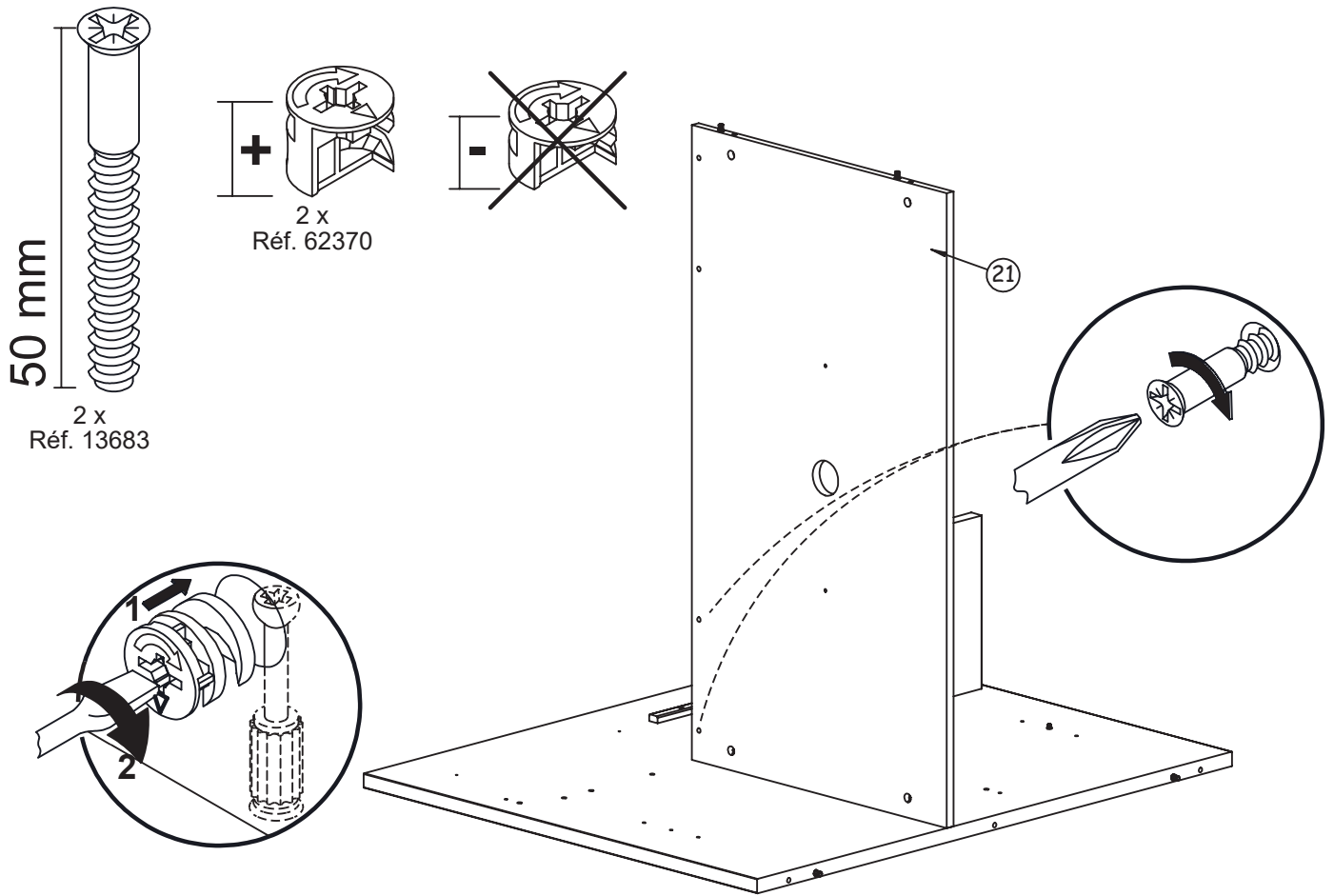

B-4

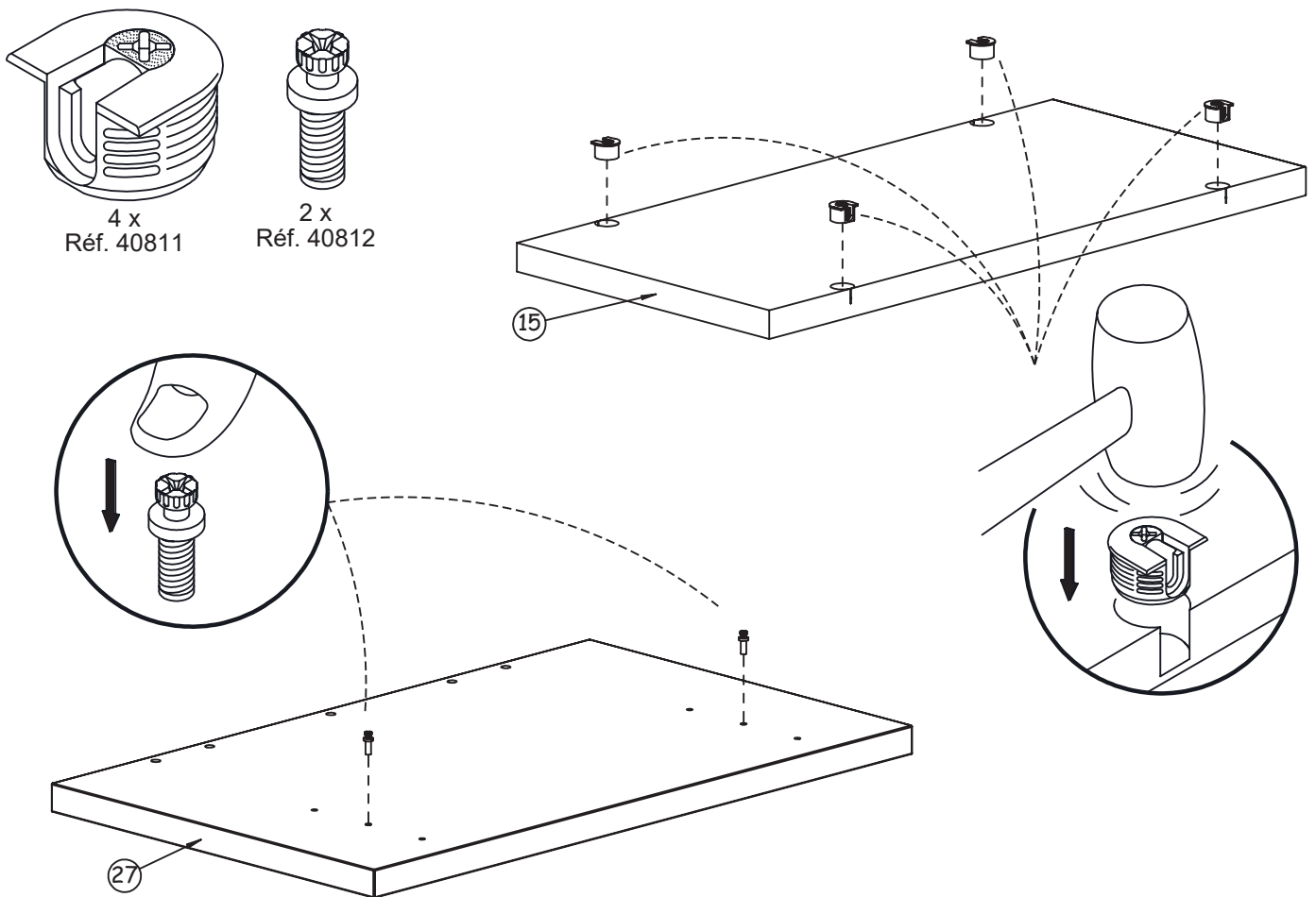

B-5

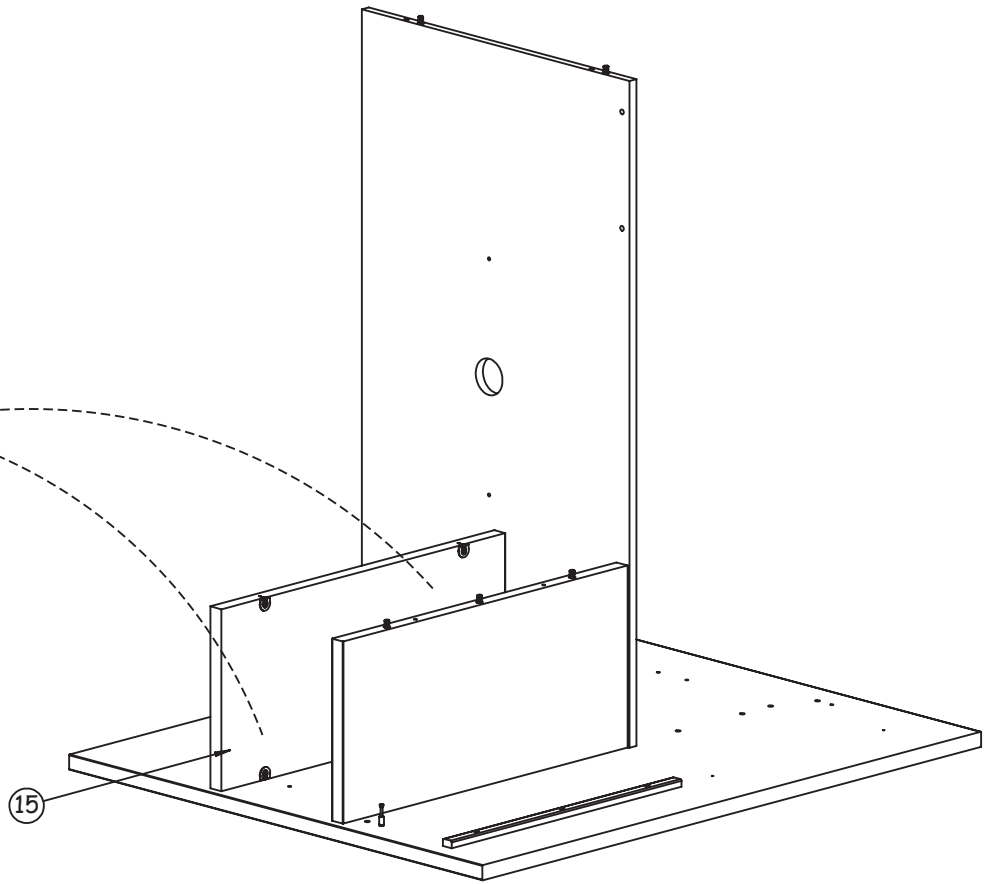
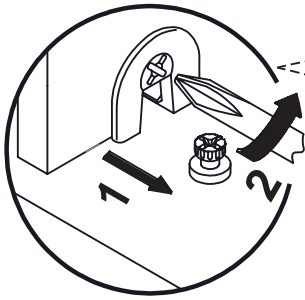

B-6

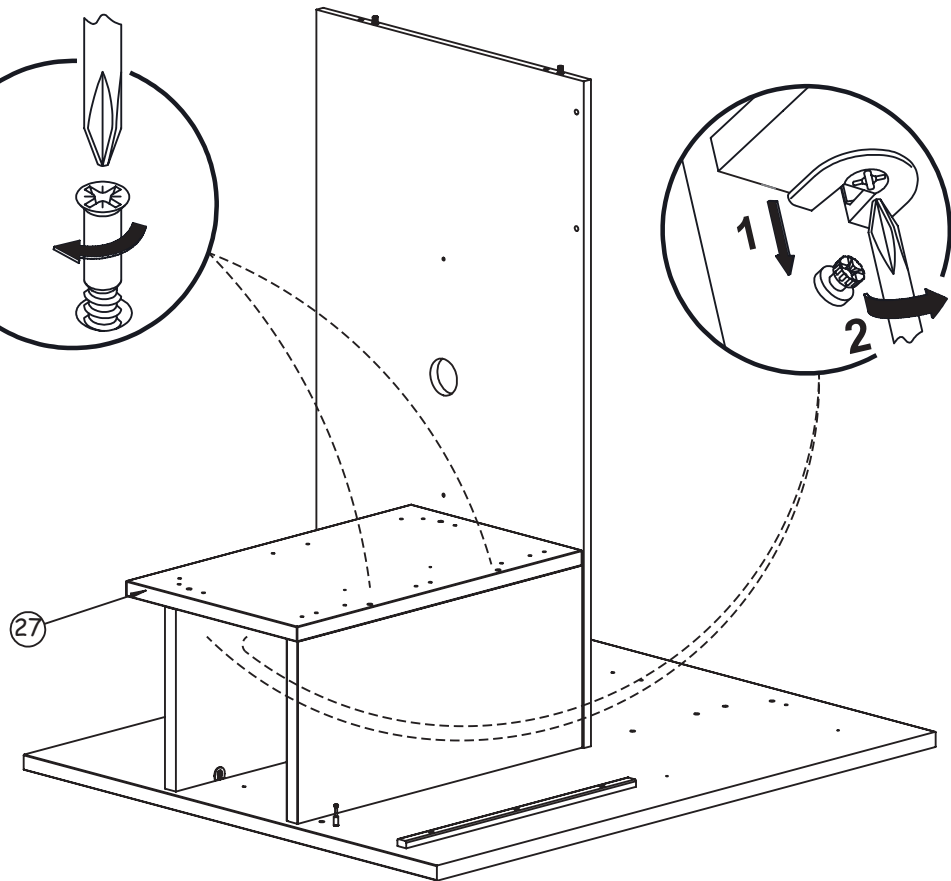
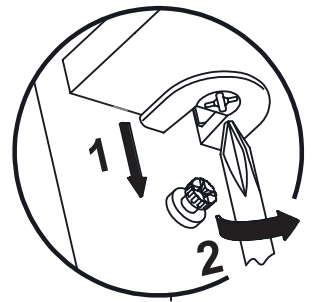
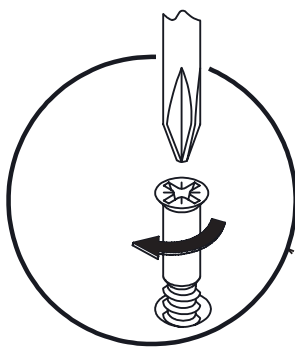
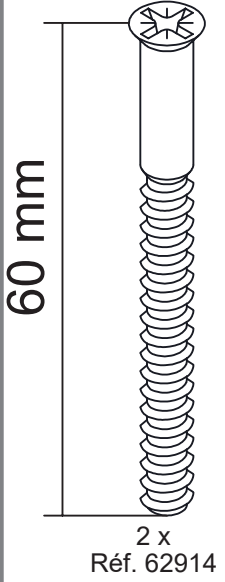

B-7

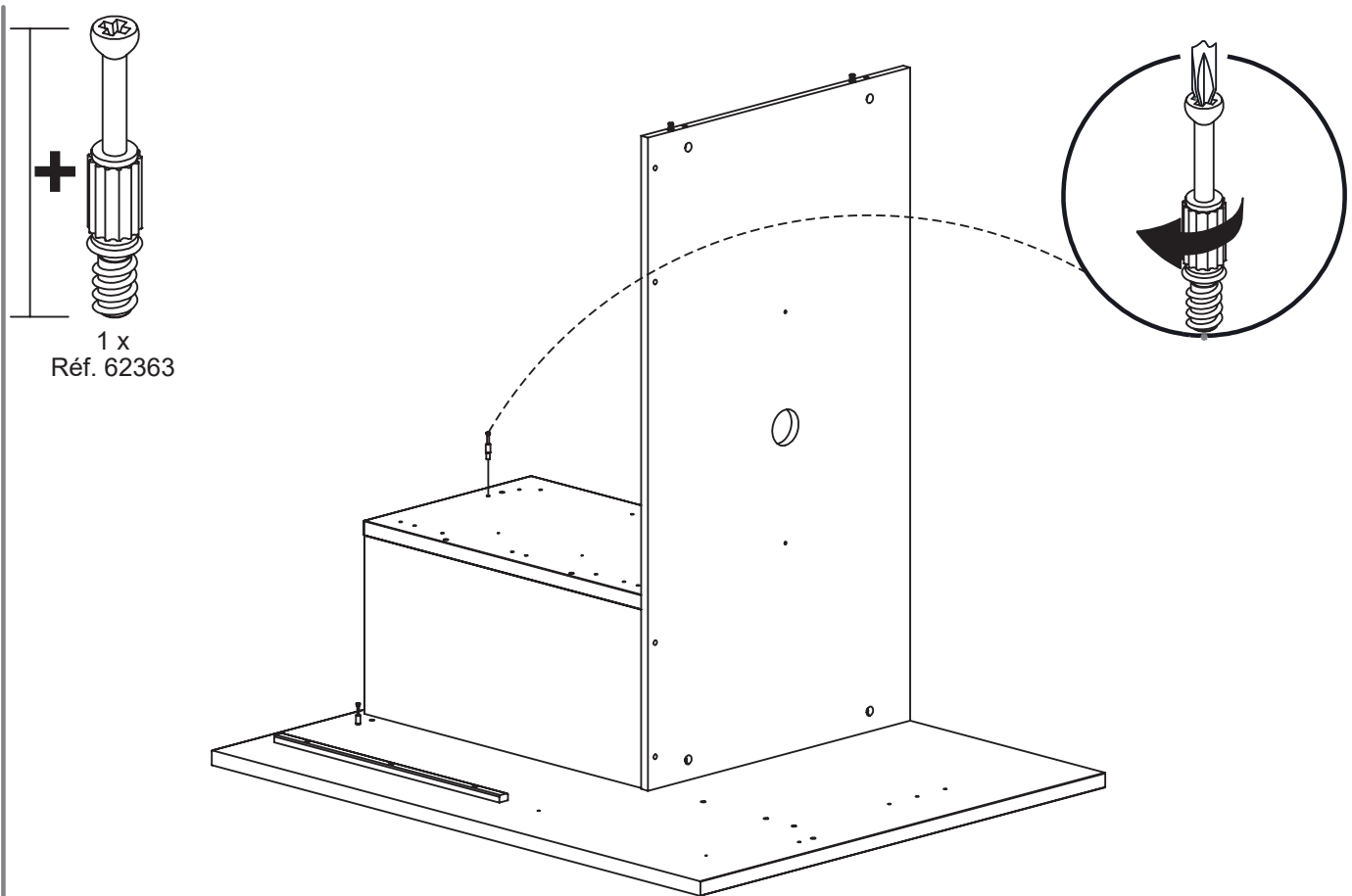

B-8

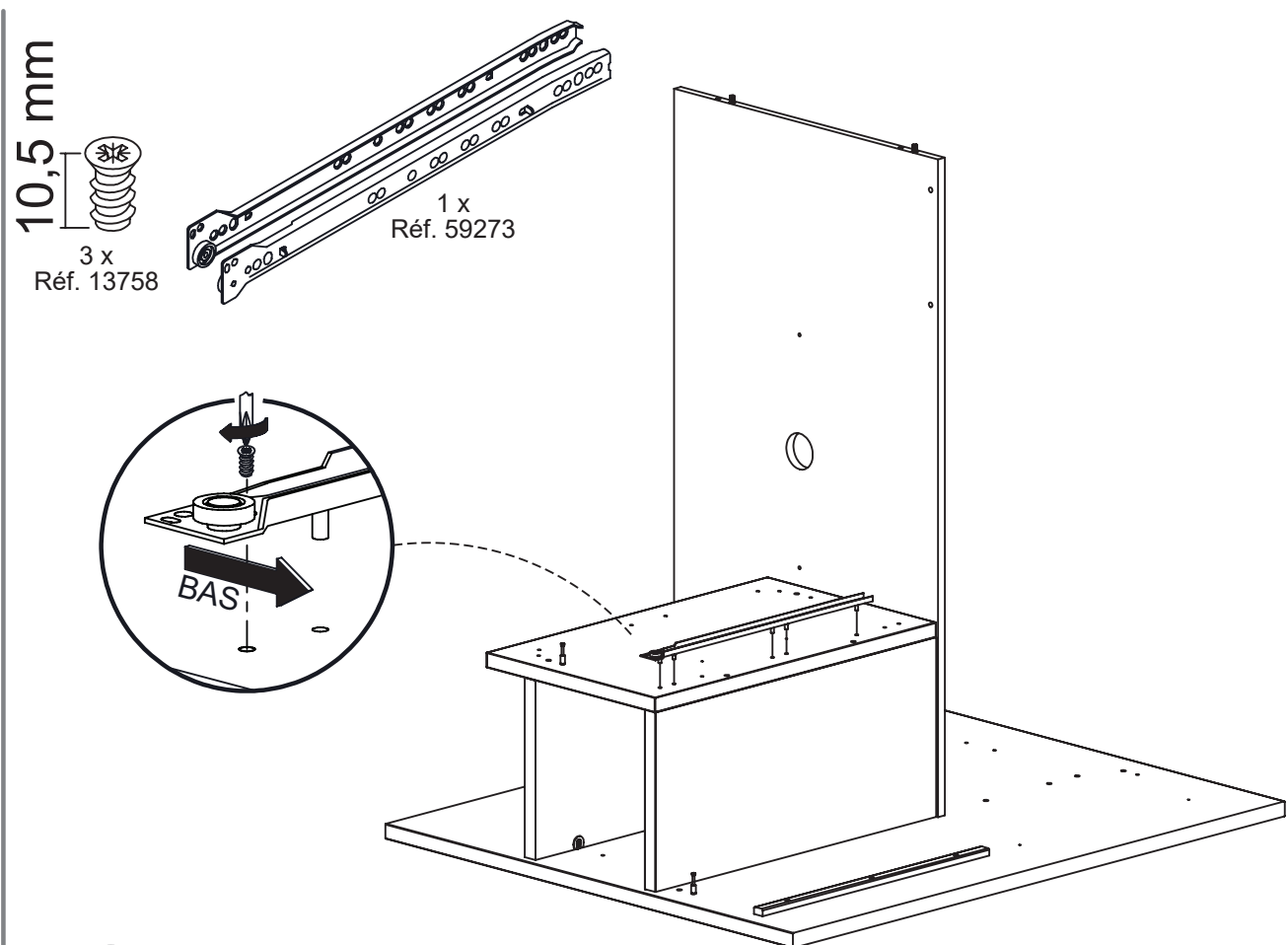

B-9

16 mm
2 x
Réf. 37181

1 x
Réf. 51015

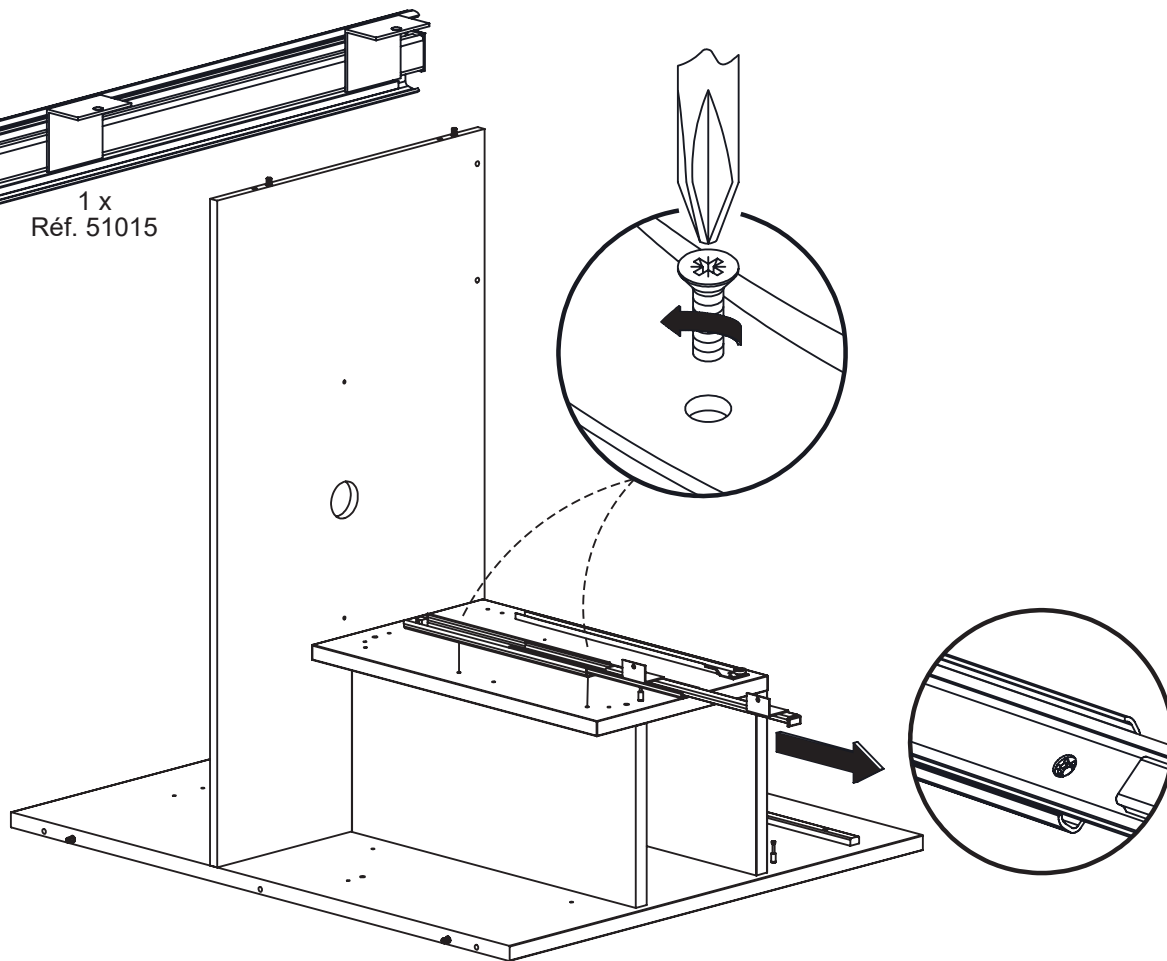

B-10

16 mm
2 x
Réf. 12803

1 x
Réf. 6655

1 x
Réf. 54865

30 mm
3 x
Réf. 6872

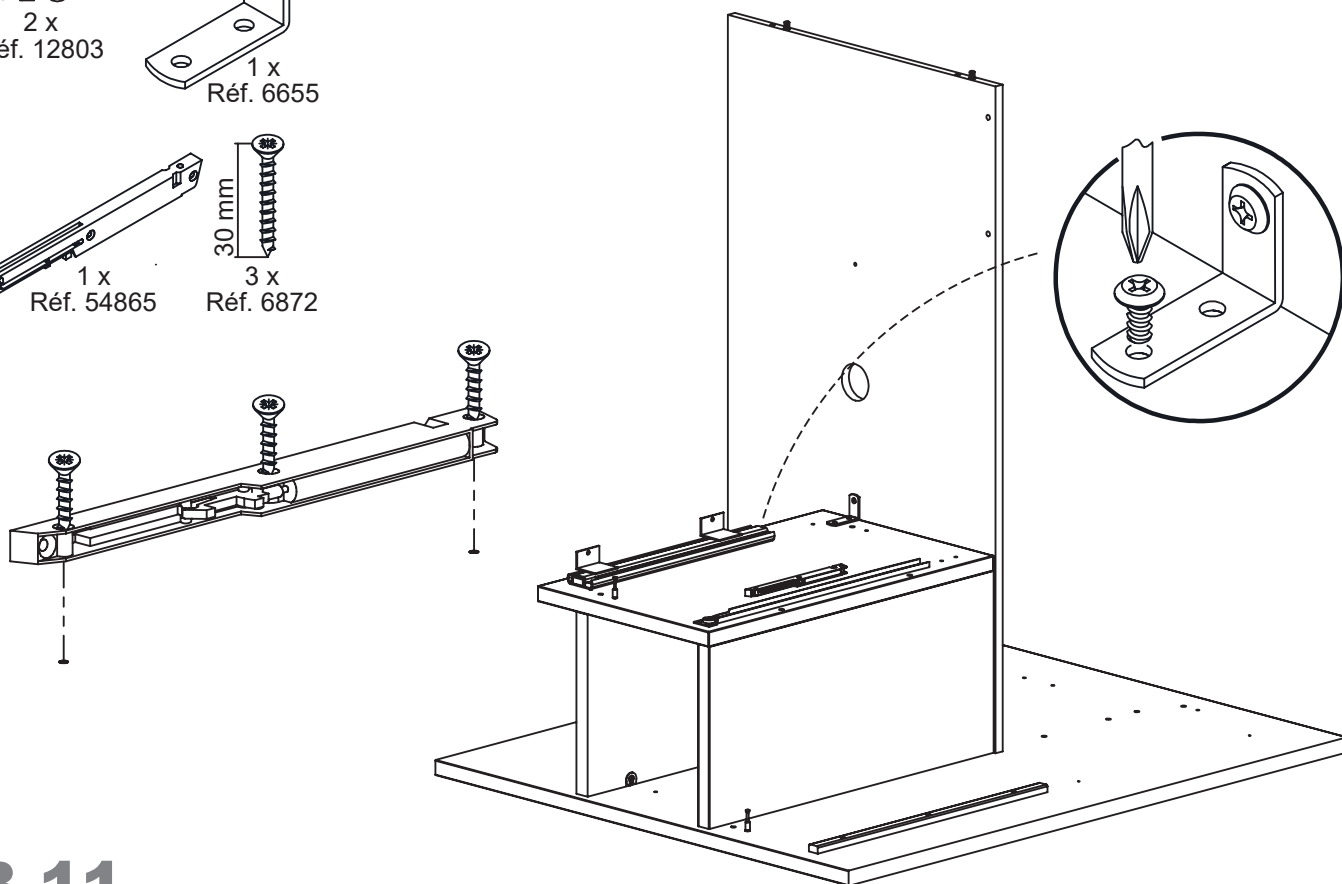

B-11

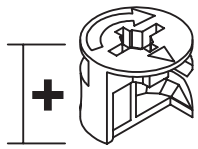

2 x
Réf. 62370

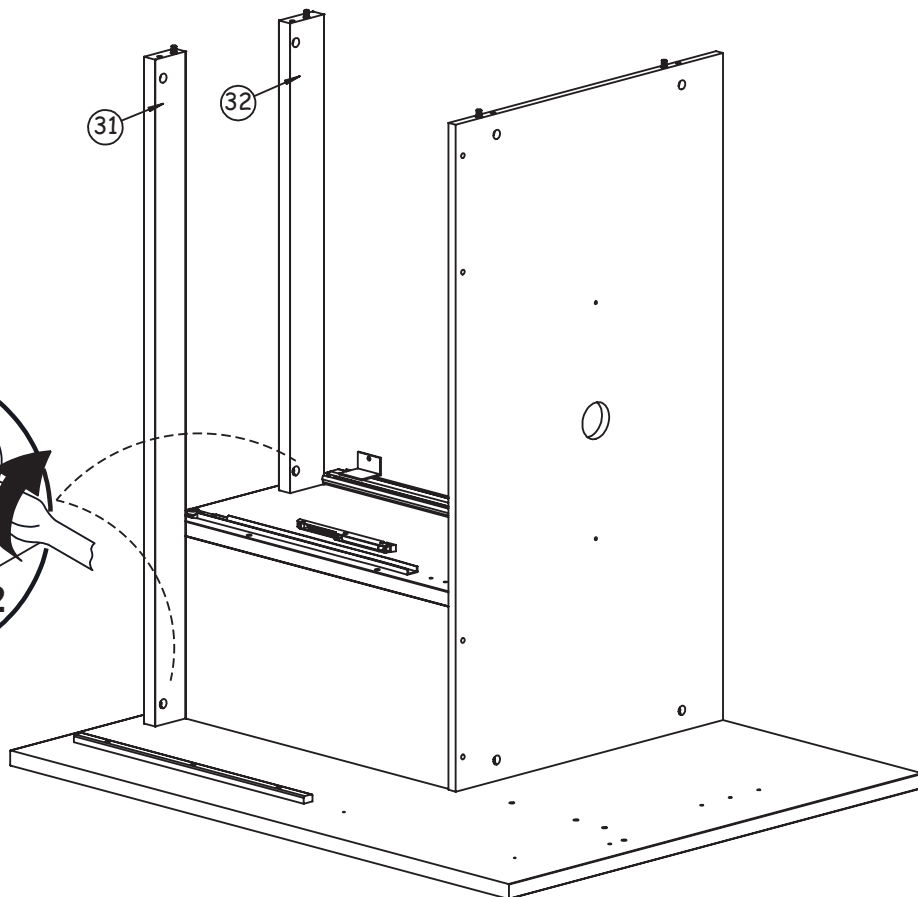
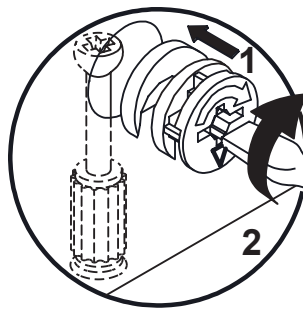

B-12

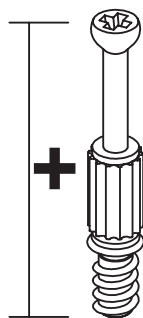

4 x
Réf. 62363

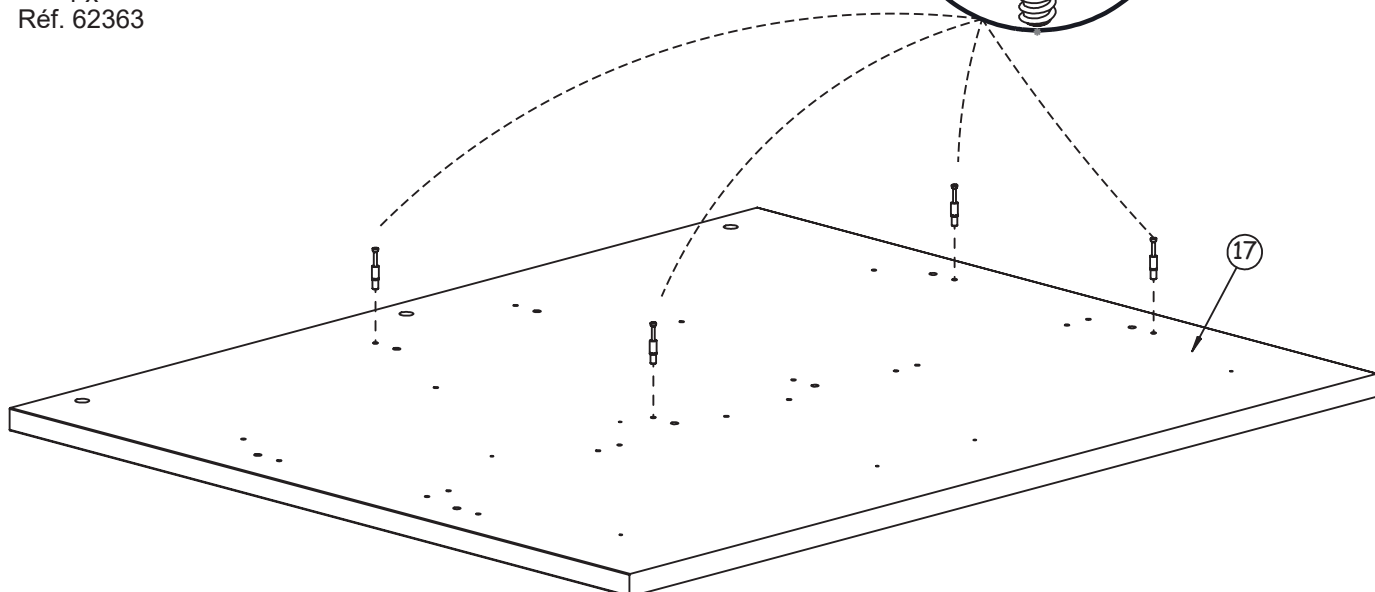
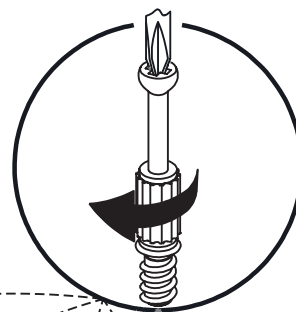

B-13

10,5 mm

3 x
Réf. 13758

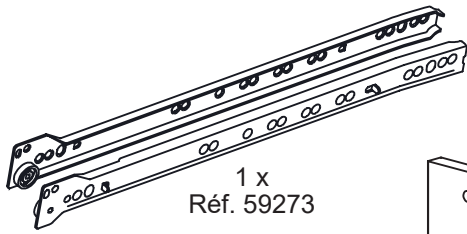

1 x
Réf. 59273

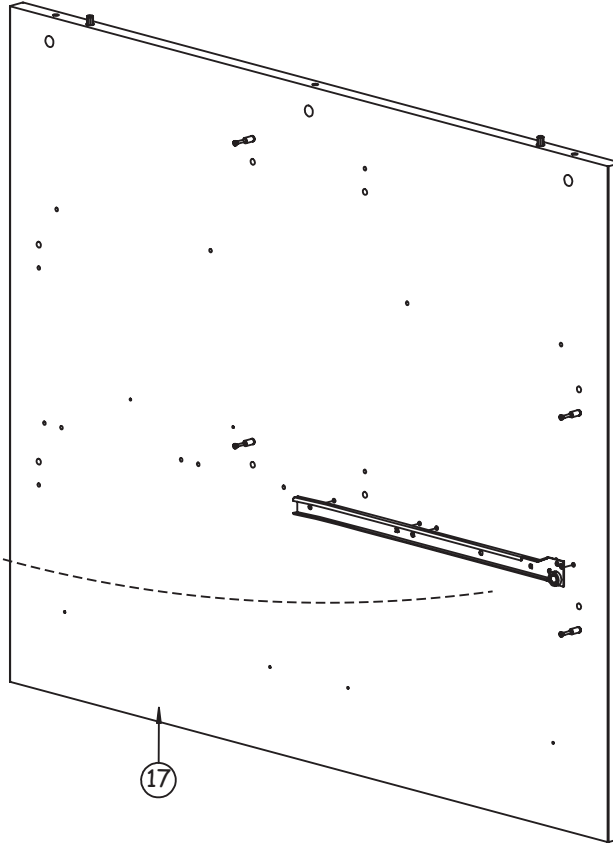
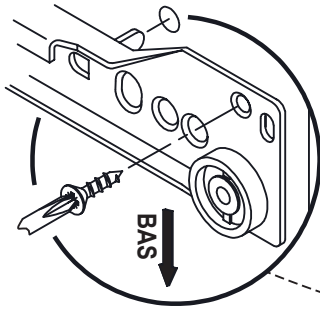

B-14

16 mm

2 x
Réf. 37181

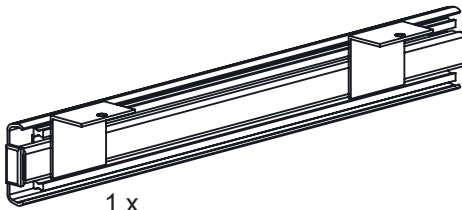

1 x
Réf. 51014

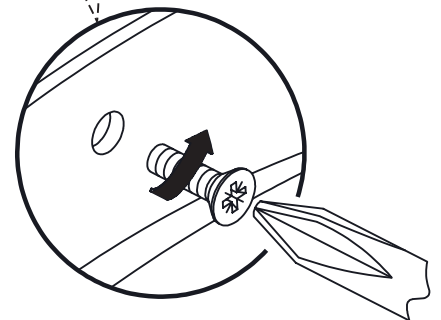
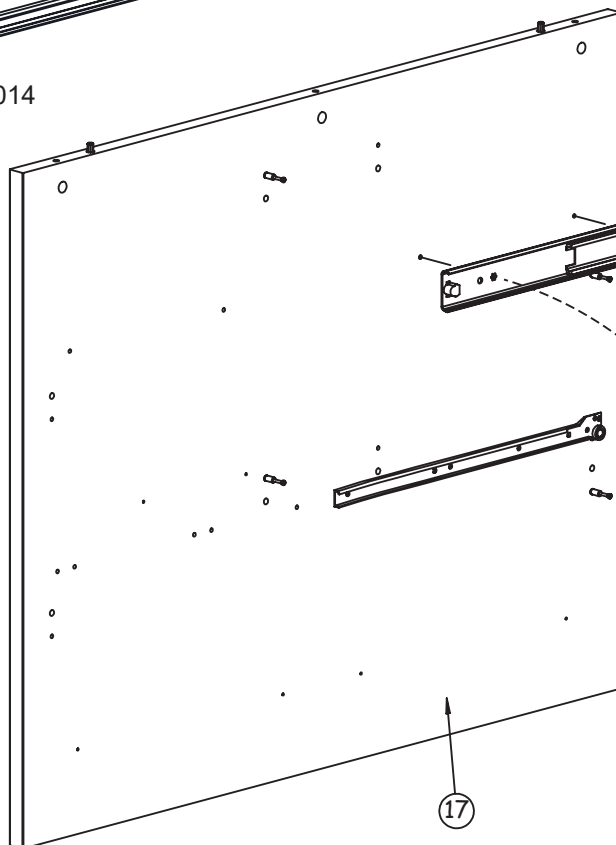
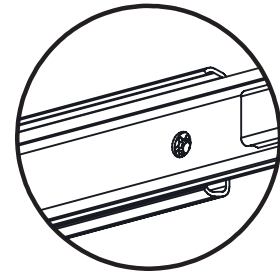

B-15

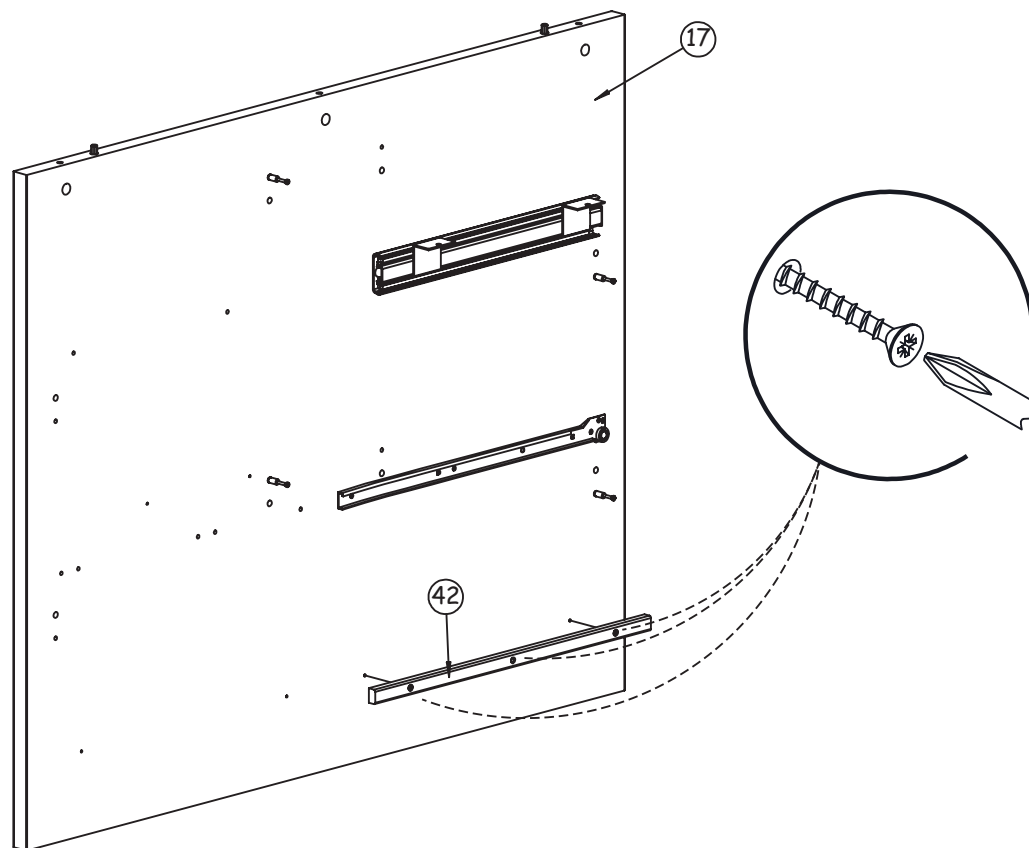
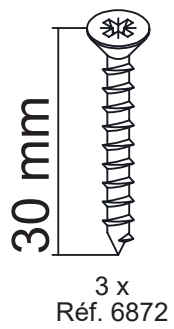

B-16

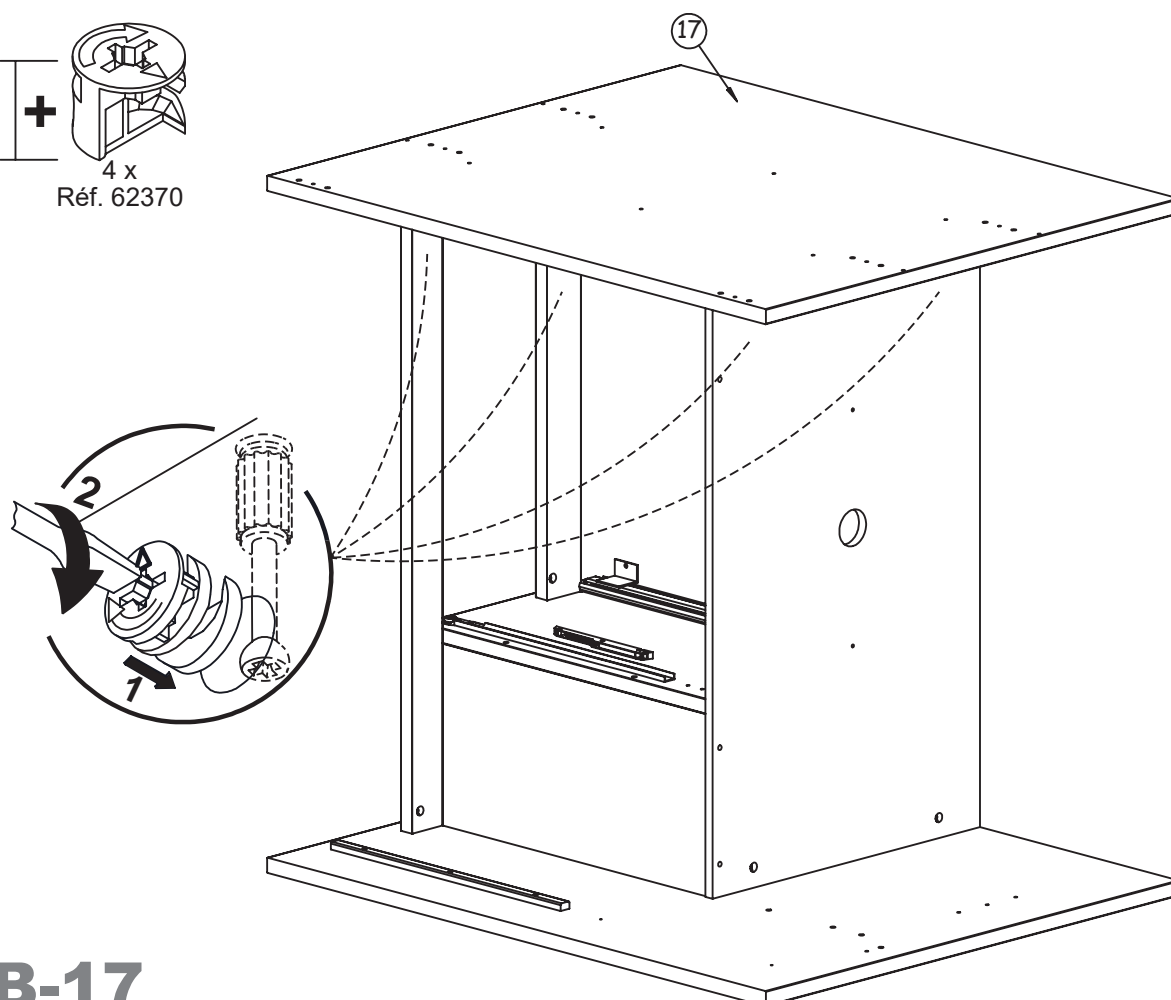
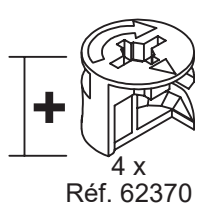

B-17

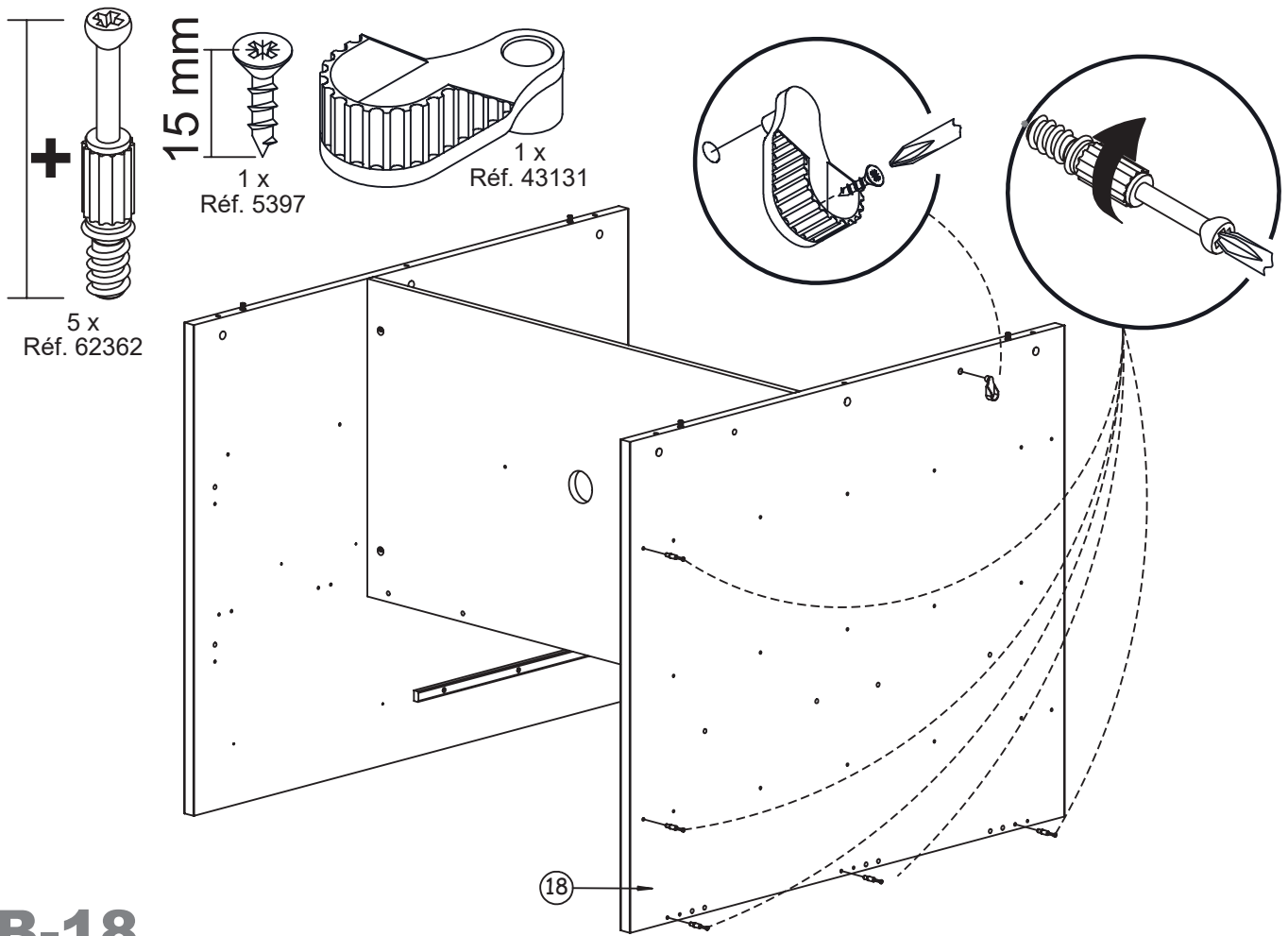

B-18

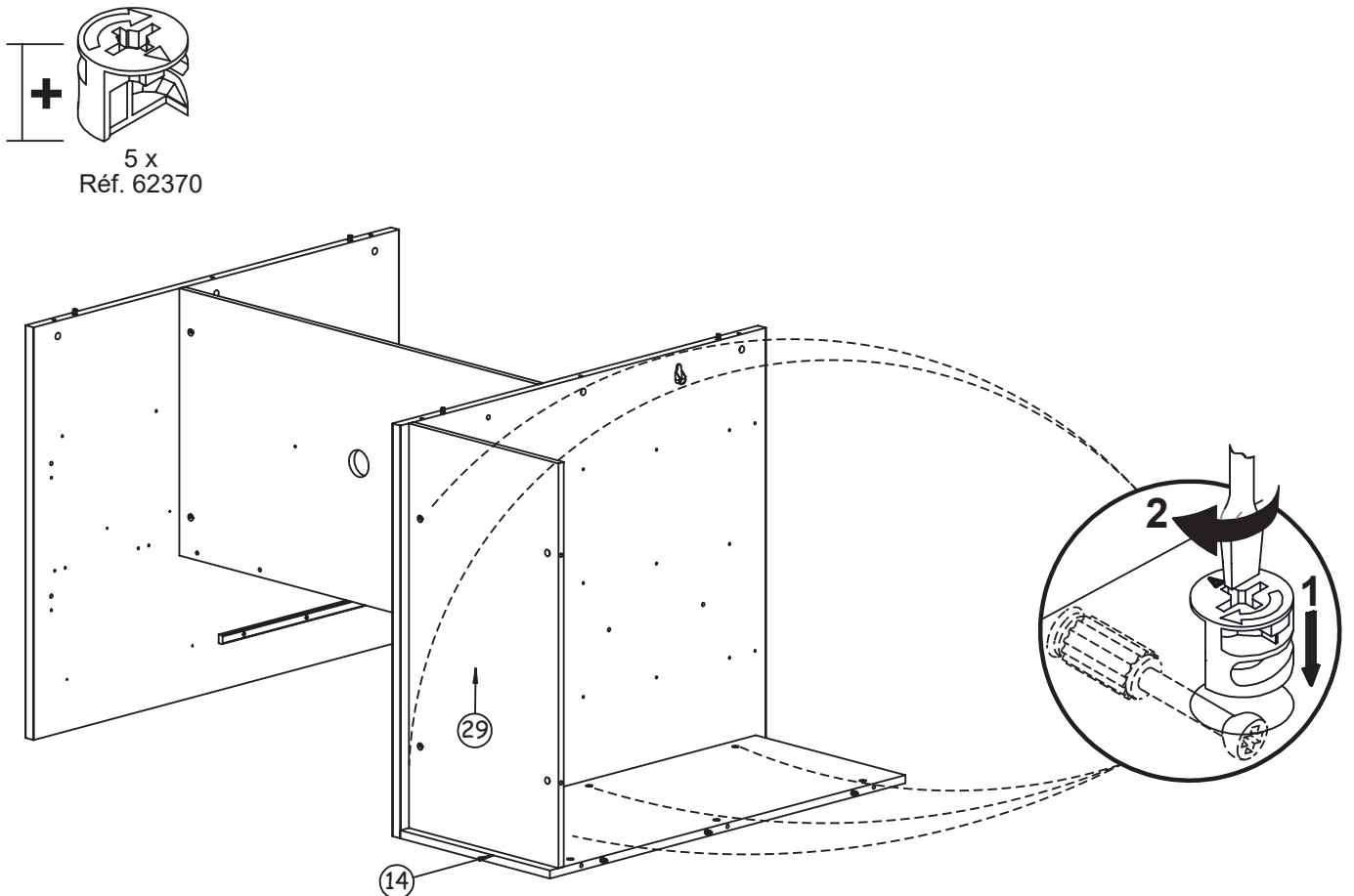

B-19

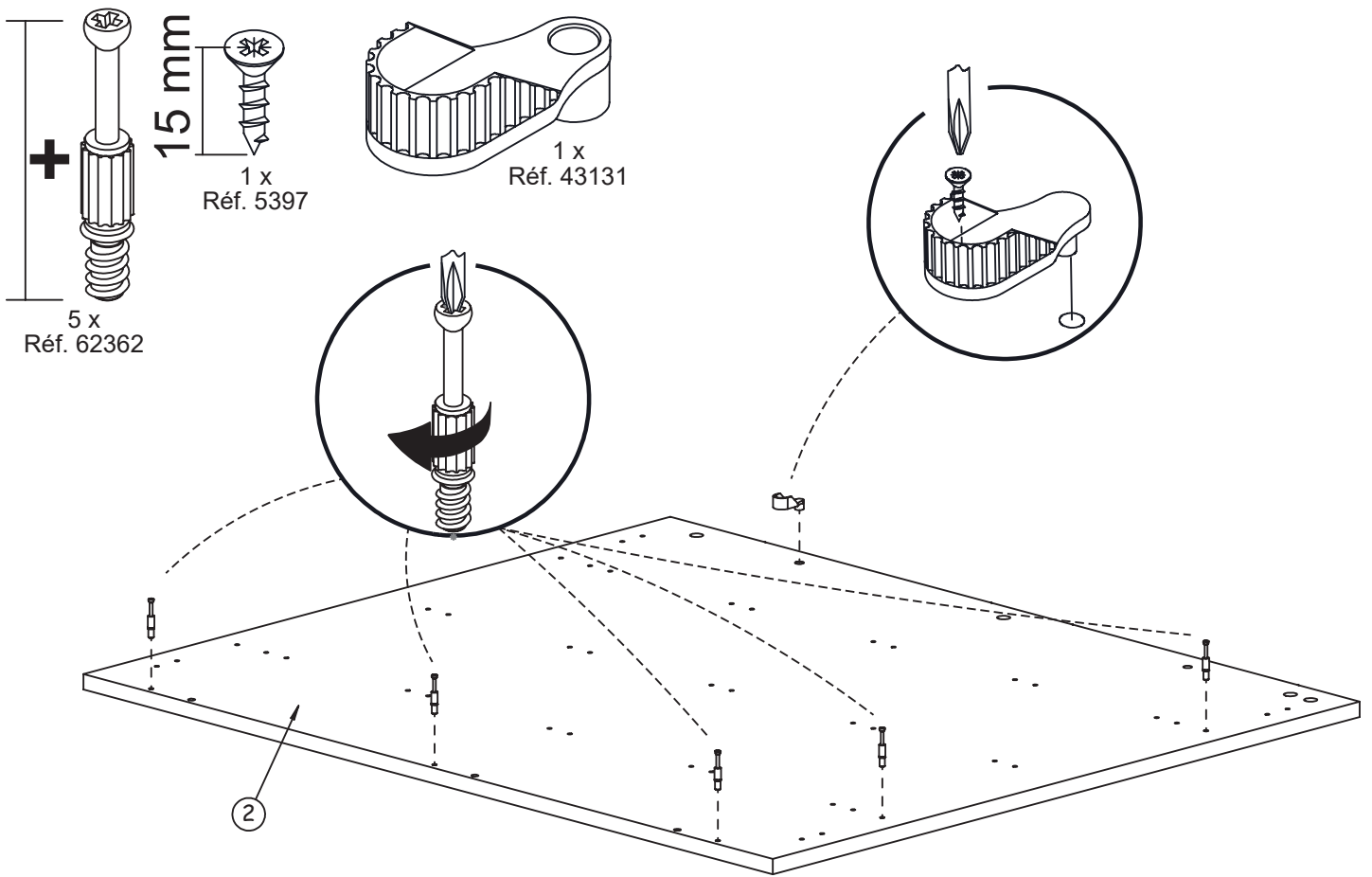

B-20

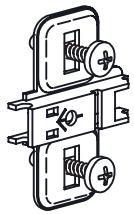

2 x
 Réf. 61874
 2

B-21

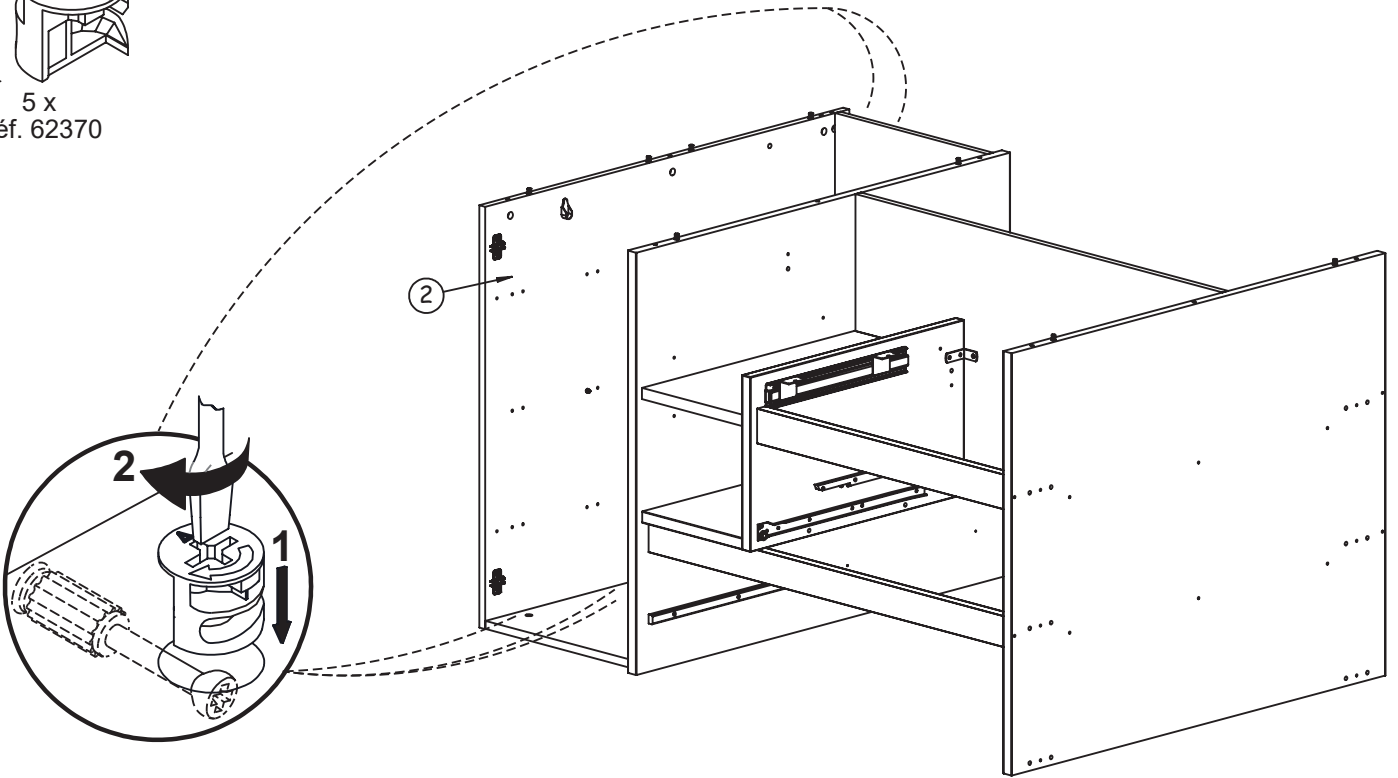
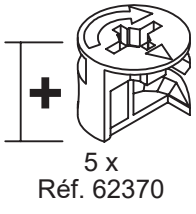

B-22

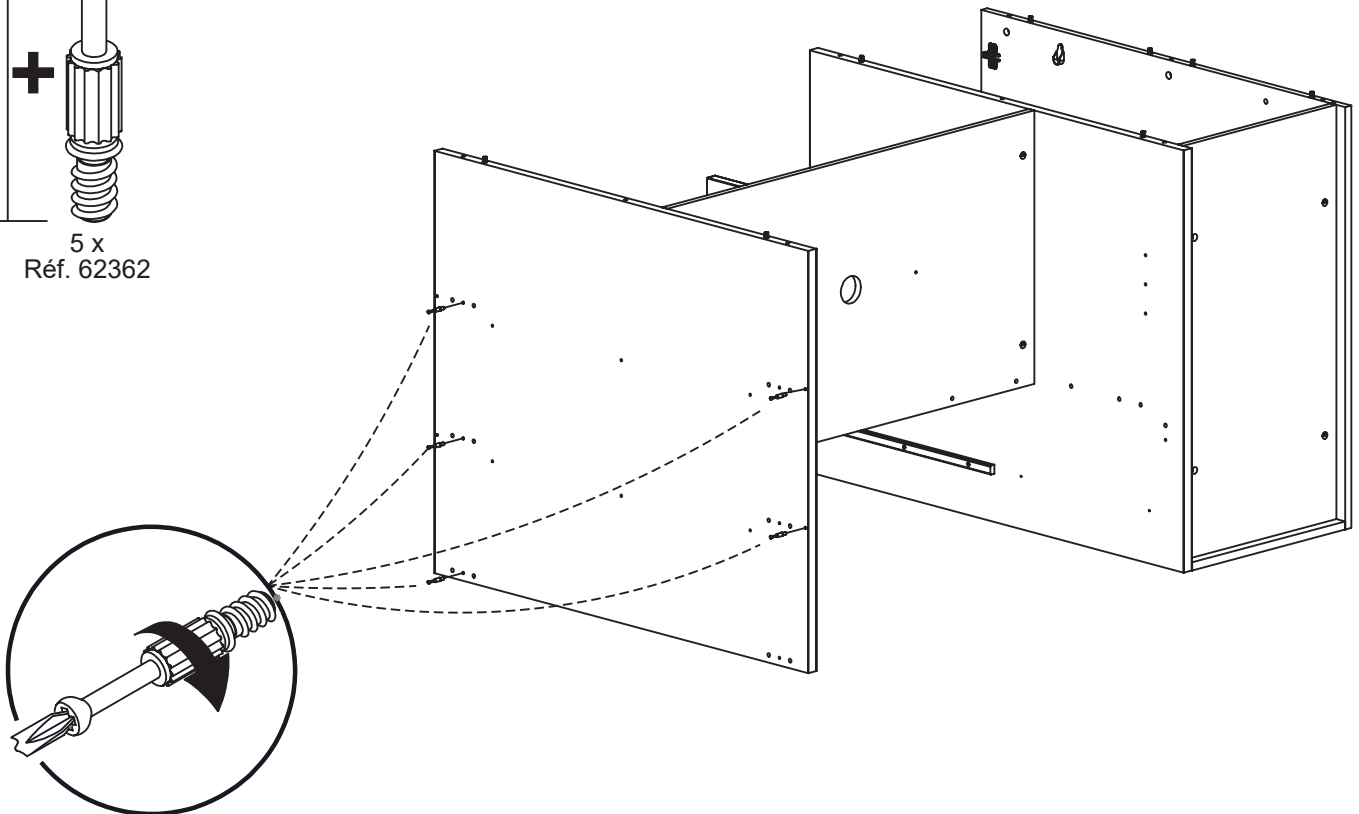
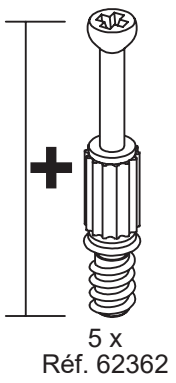

B-23

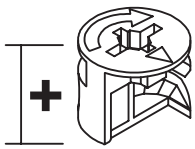

2 x
Réf. 62370

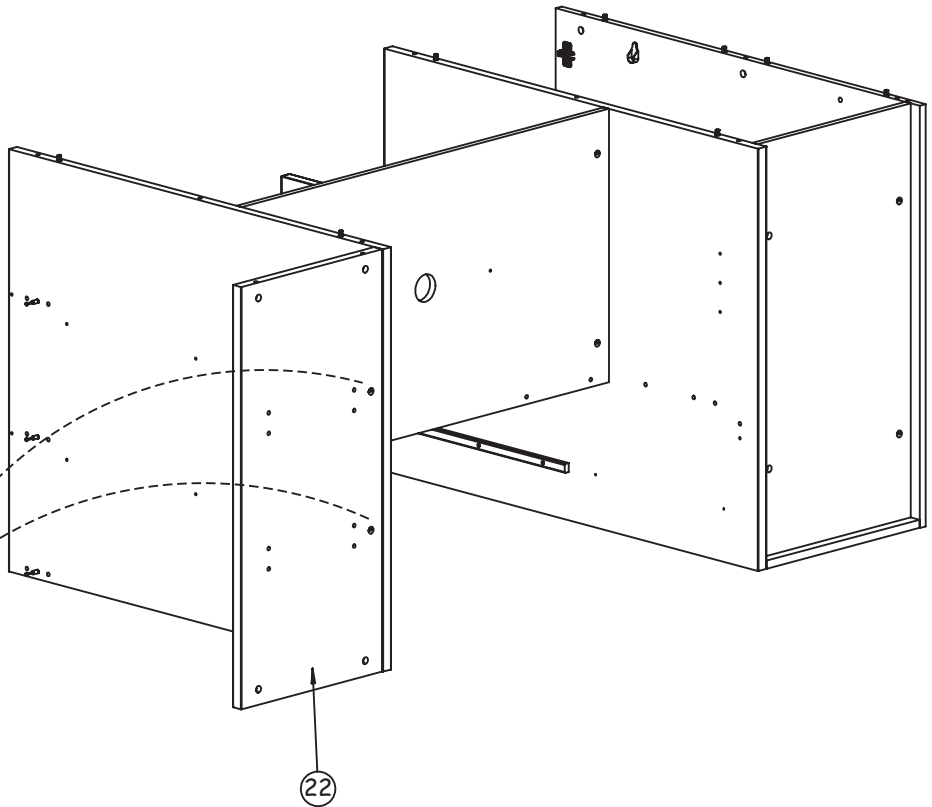
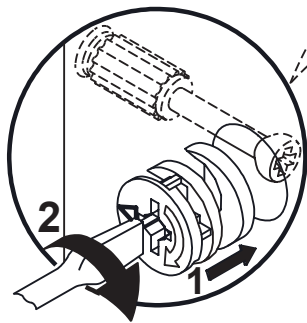

24-A

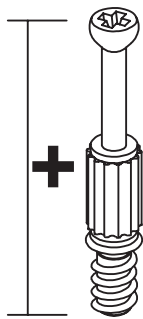

3 x
Réf. 62362

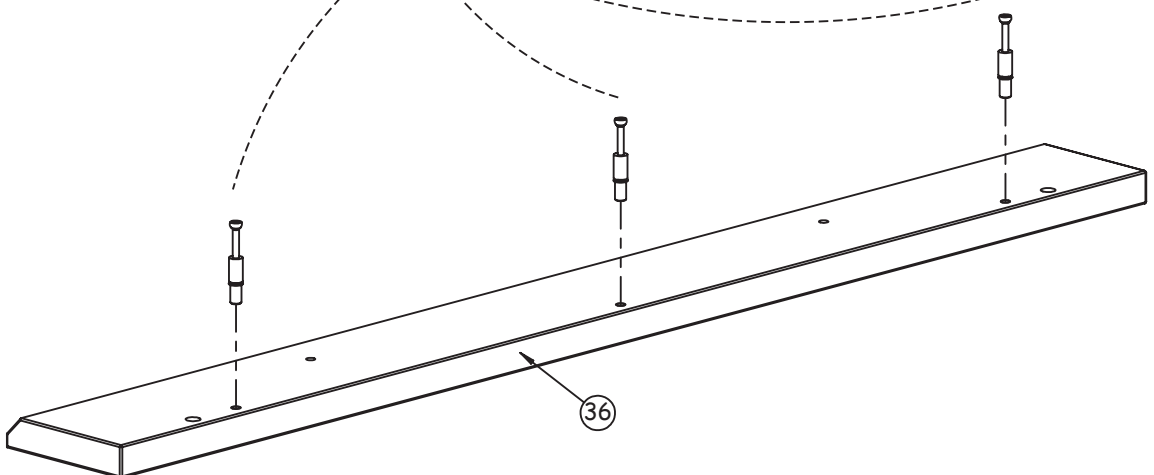
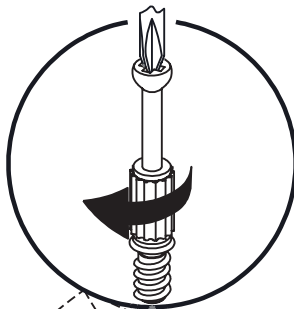

25-A

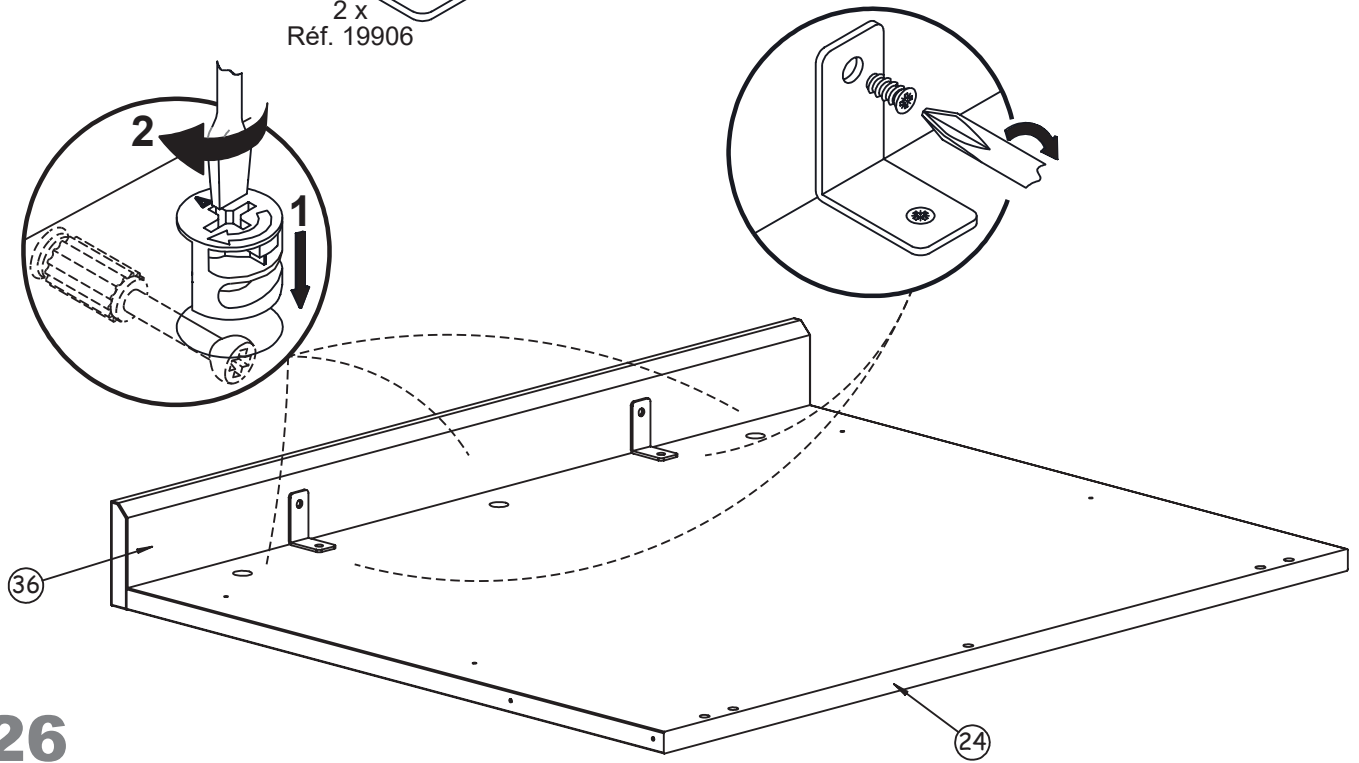
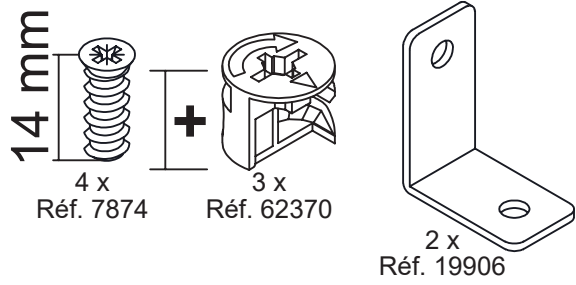

B-26

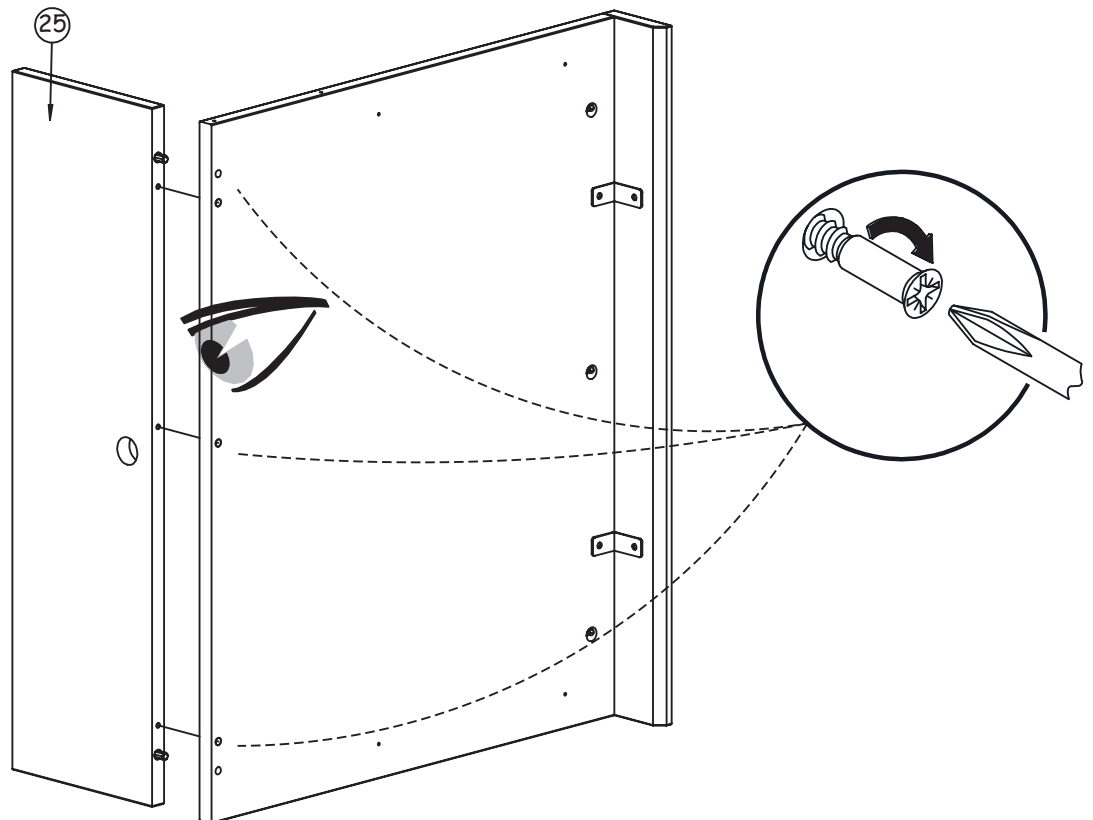
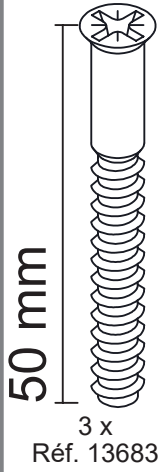

B-27

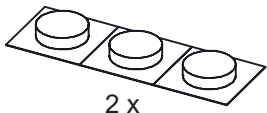

2 x
Réf. 62840

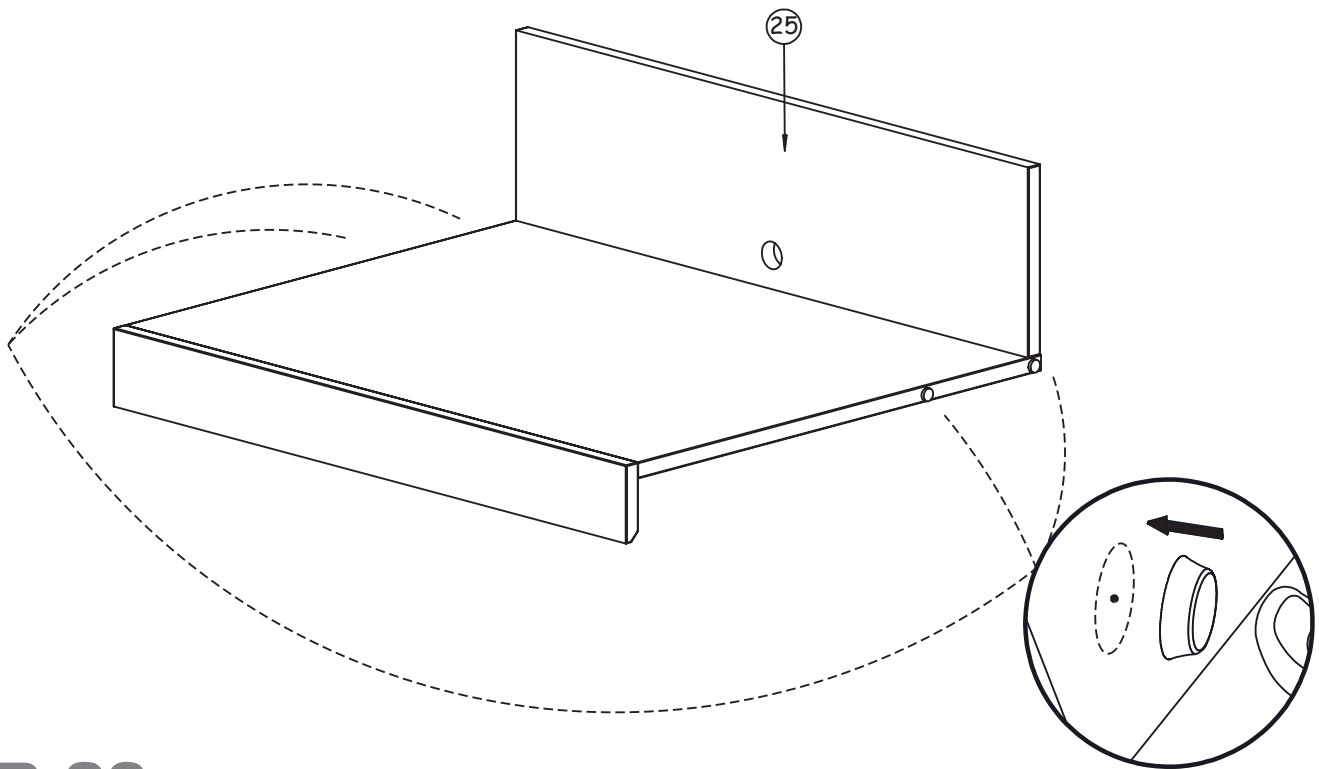

B-28

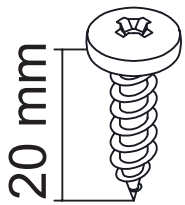

20 mm
4 x
Réf. 5398

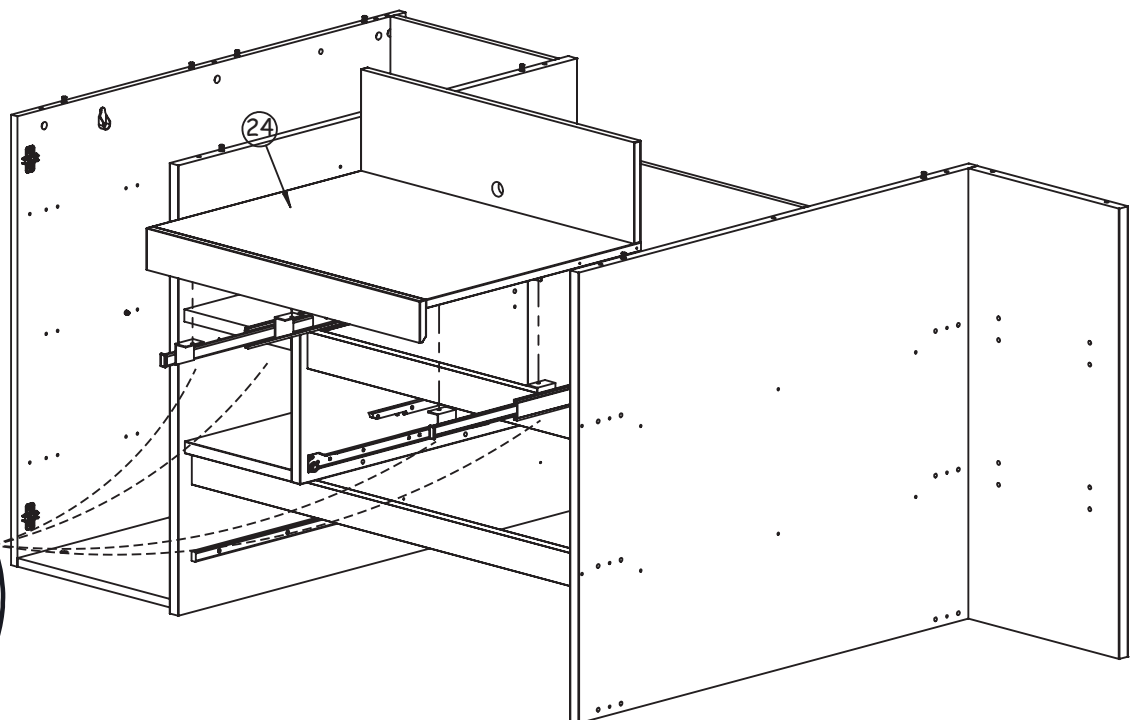
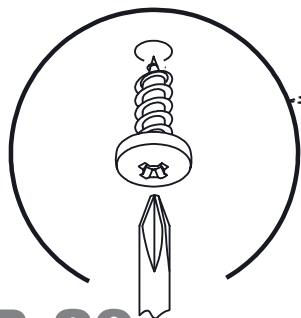
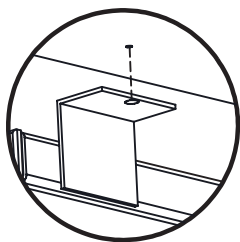

B-29

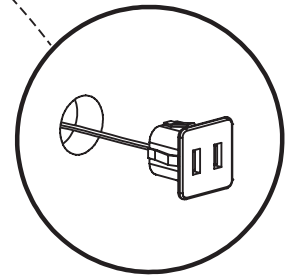
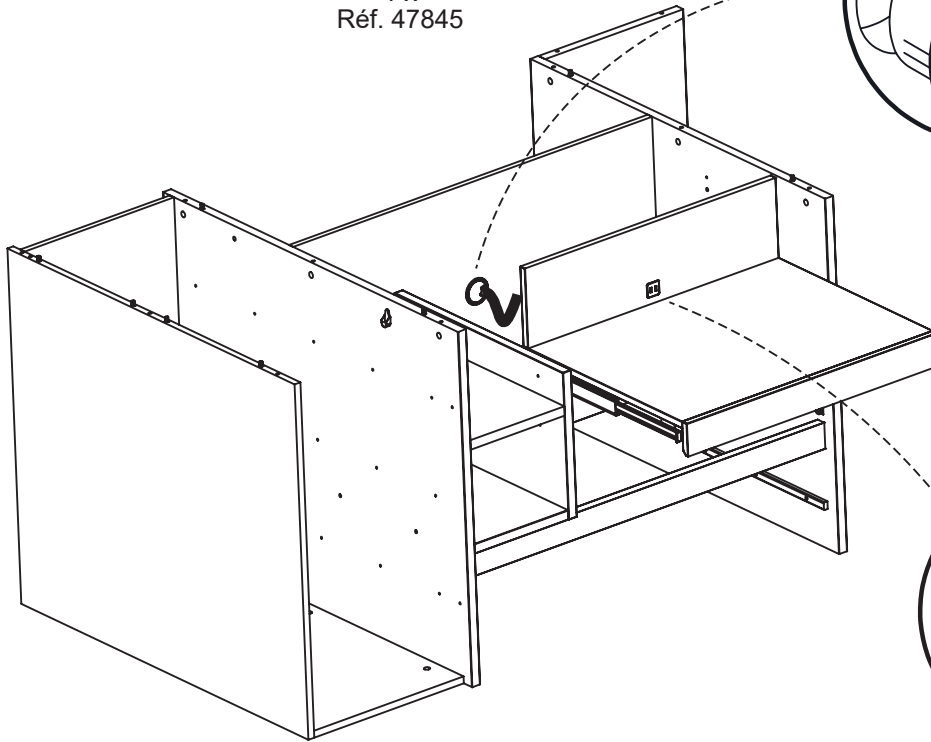
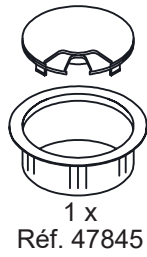
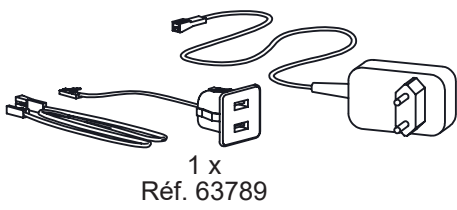

B-30

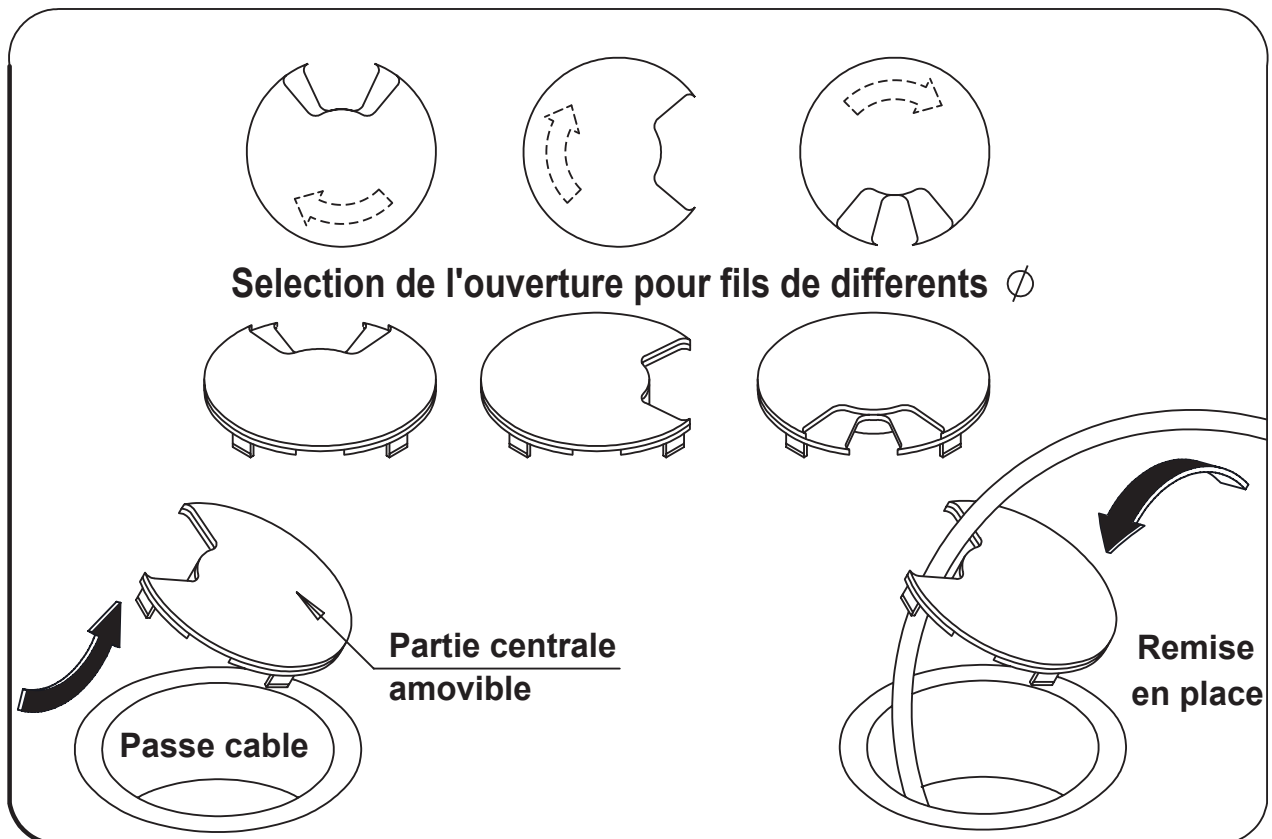

B-31

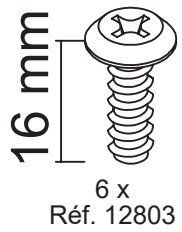

6 x
Réf. 12803

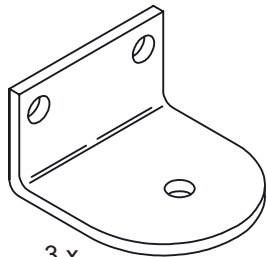

3 x
Réf. 64324

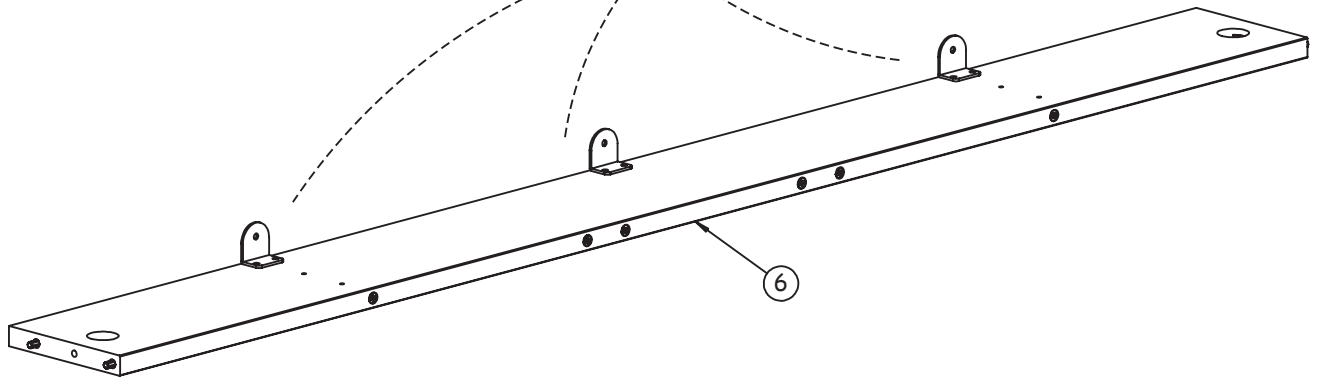
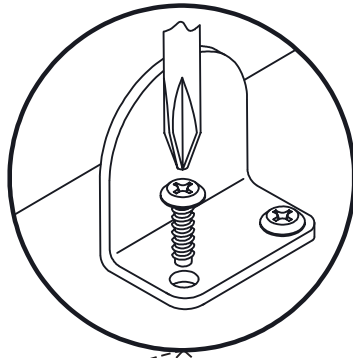

B-32

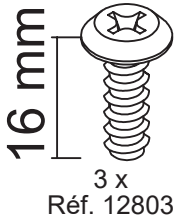

3 x
Réf. 12803

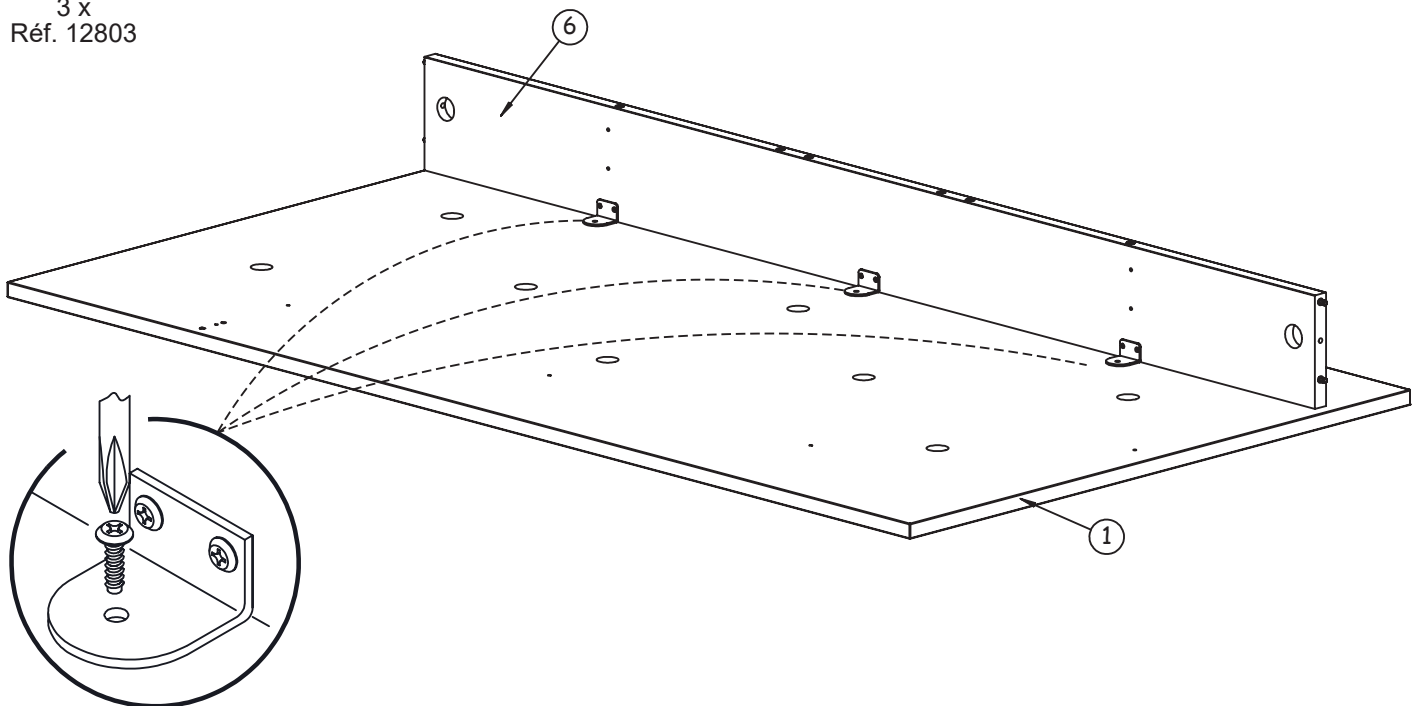

B-33

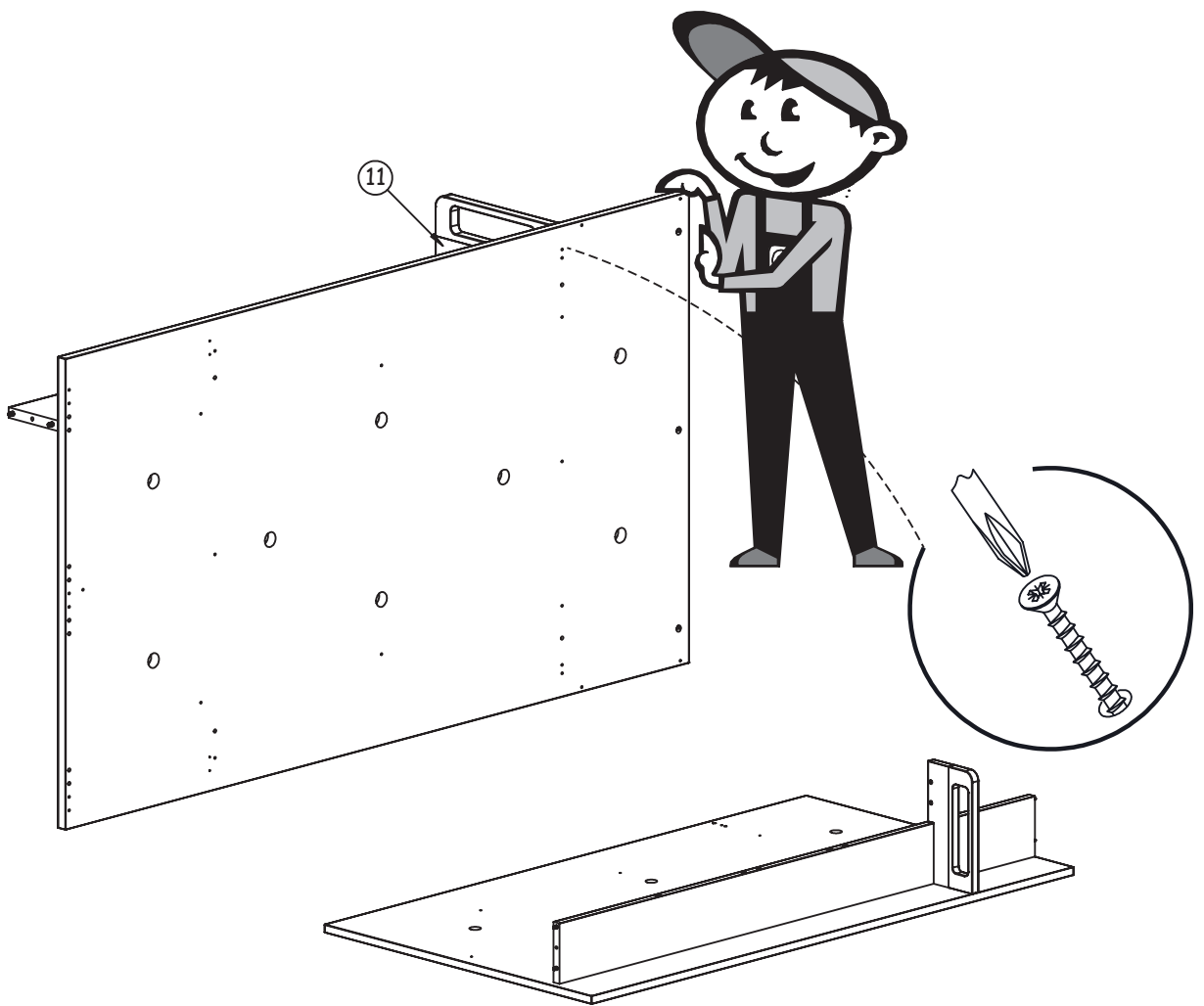
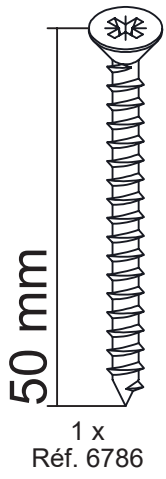

B-34

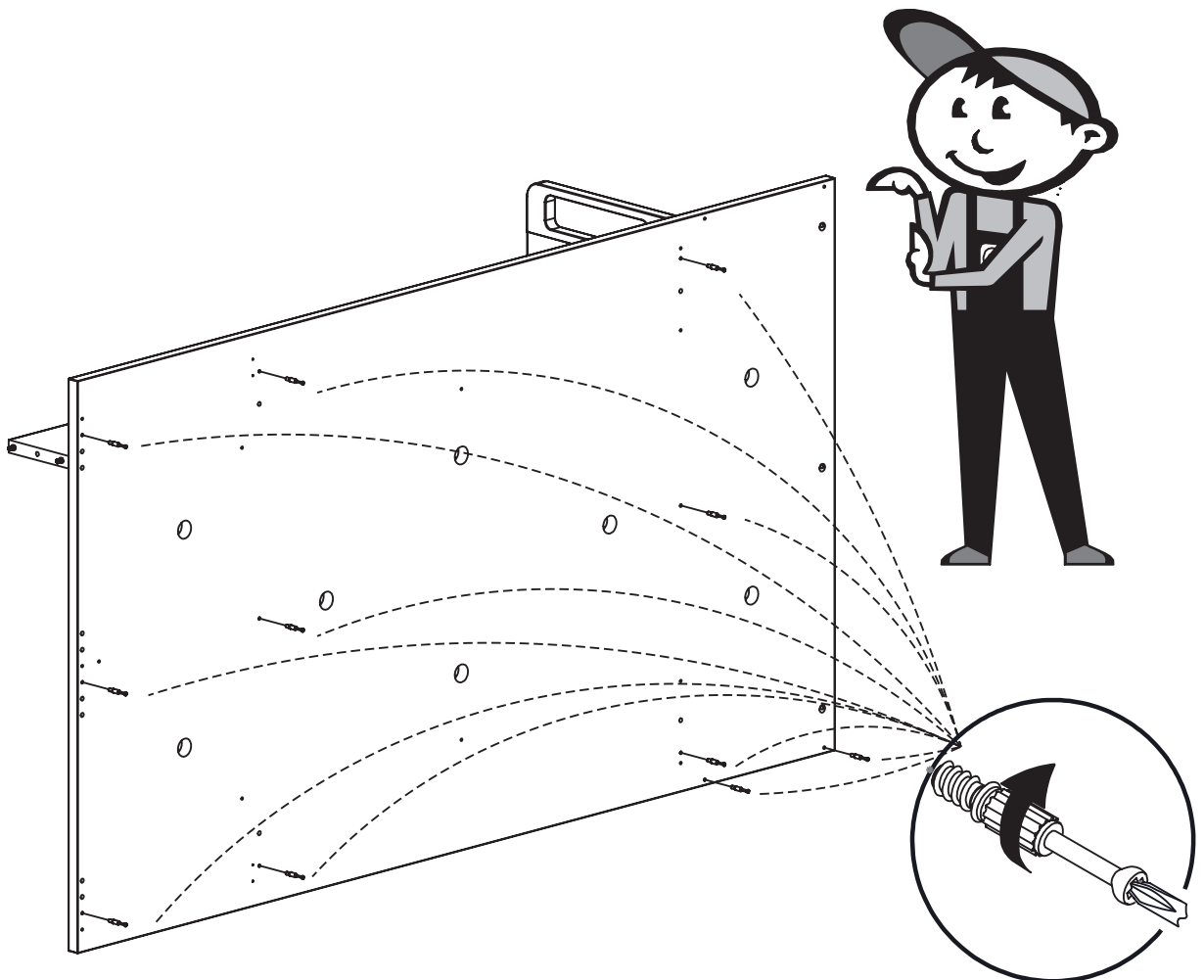
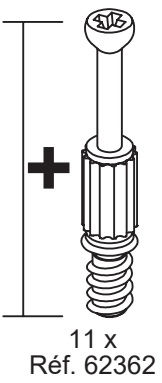

B-35

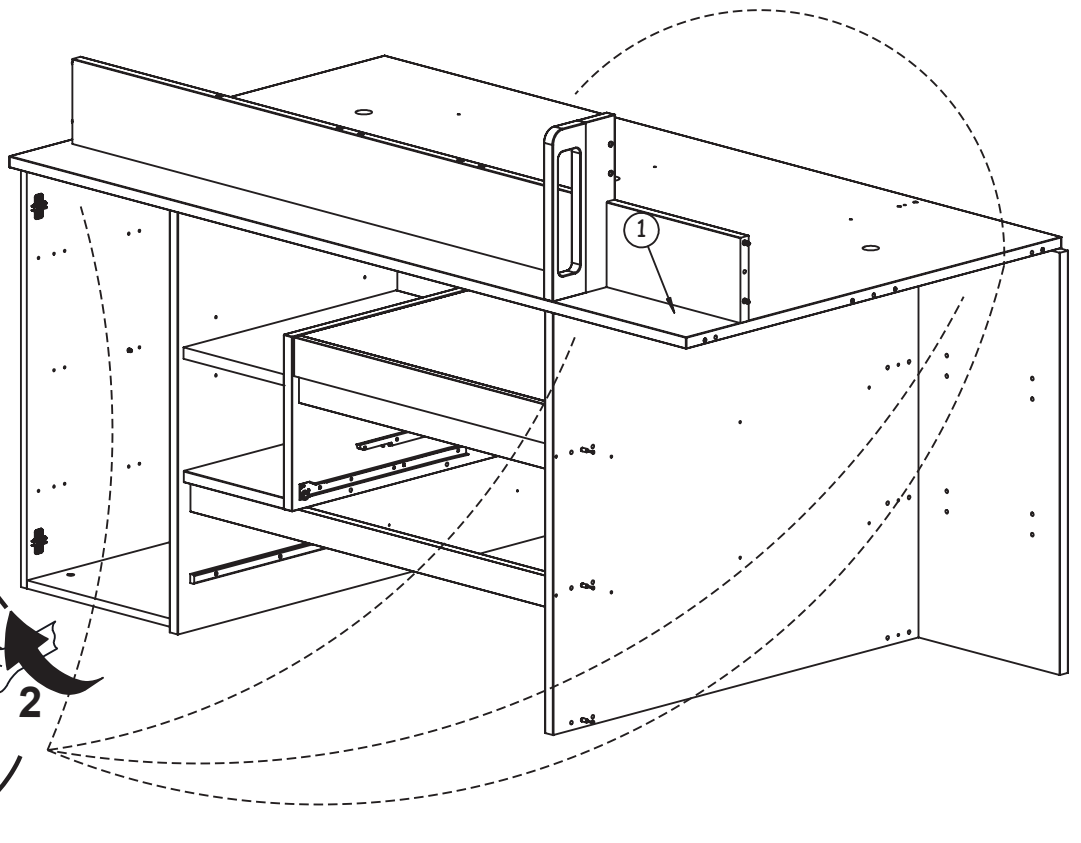
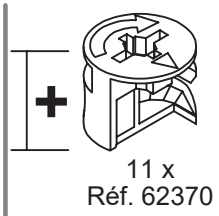

B-36

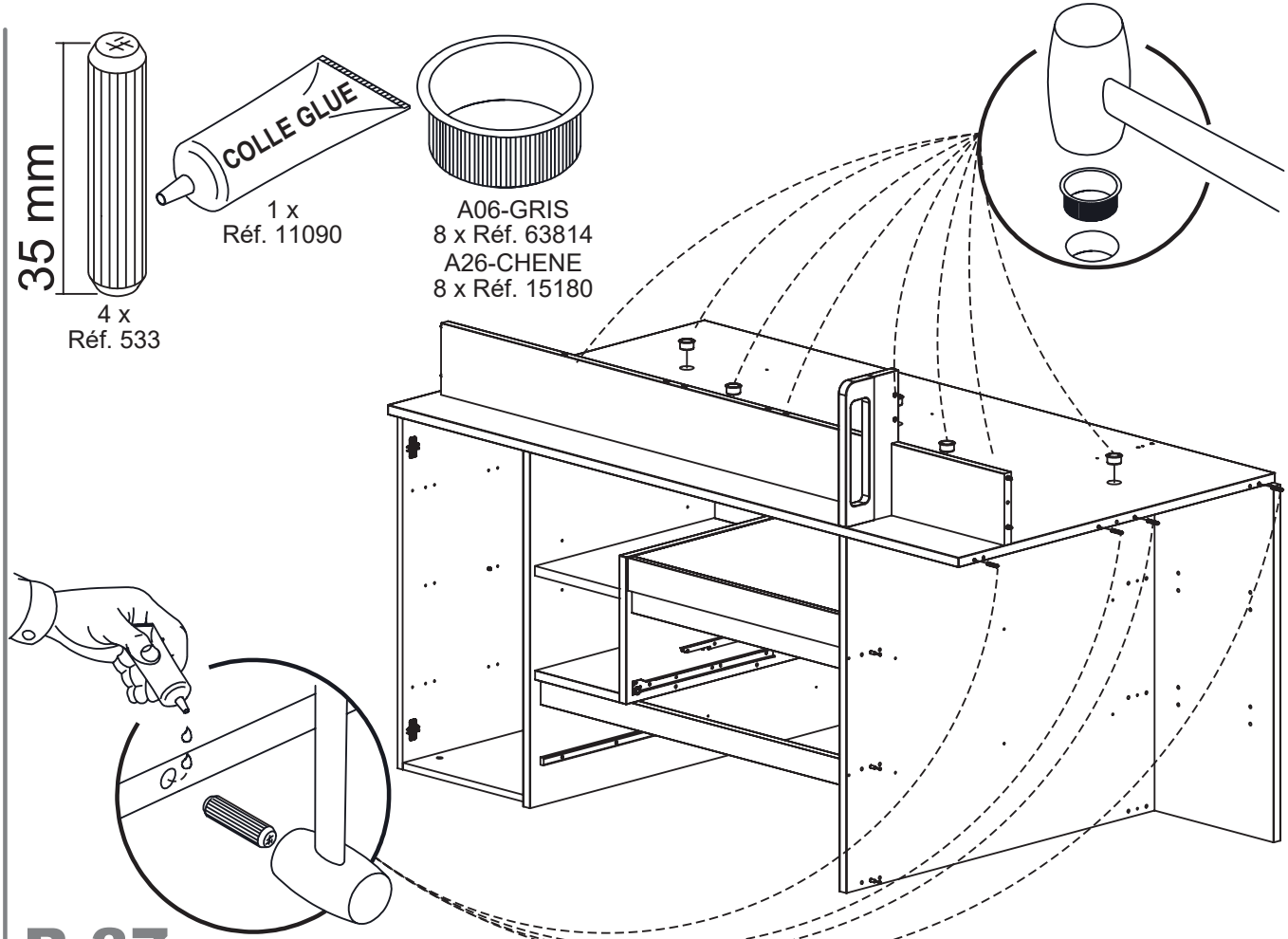

B-37

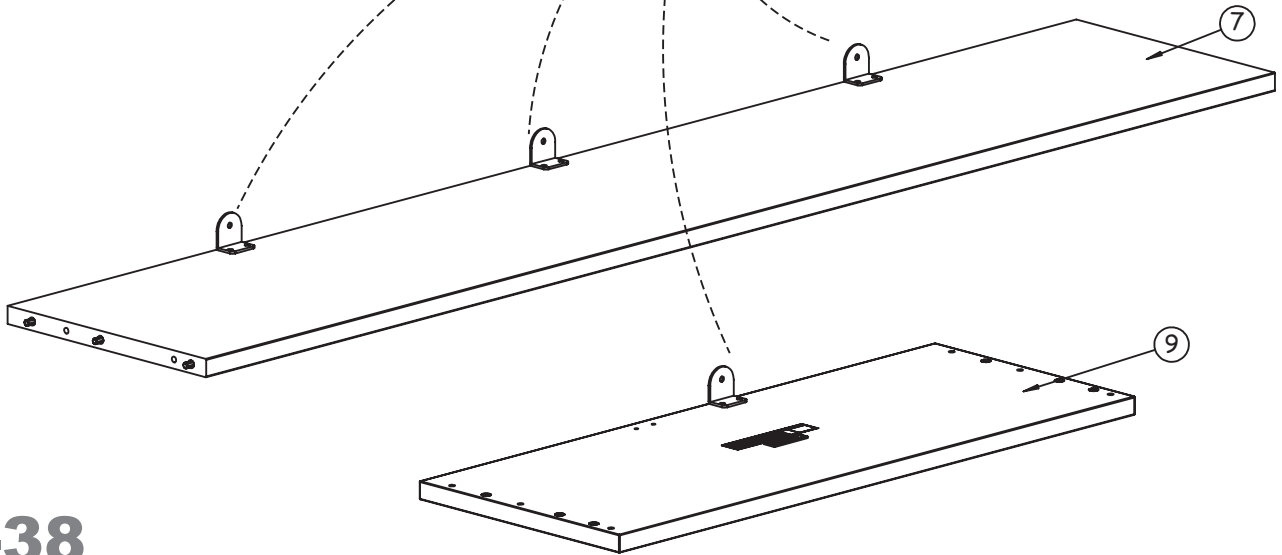
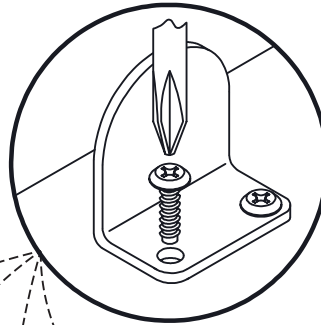
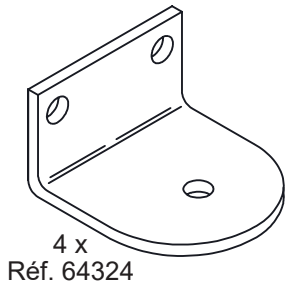
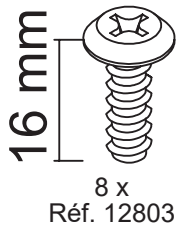

B-38

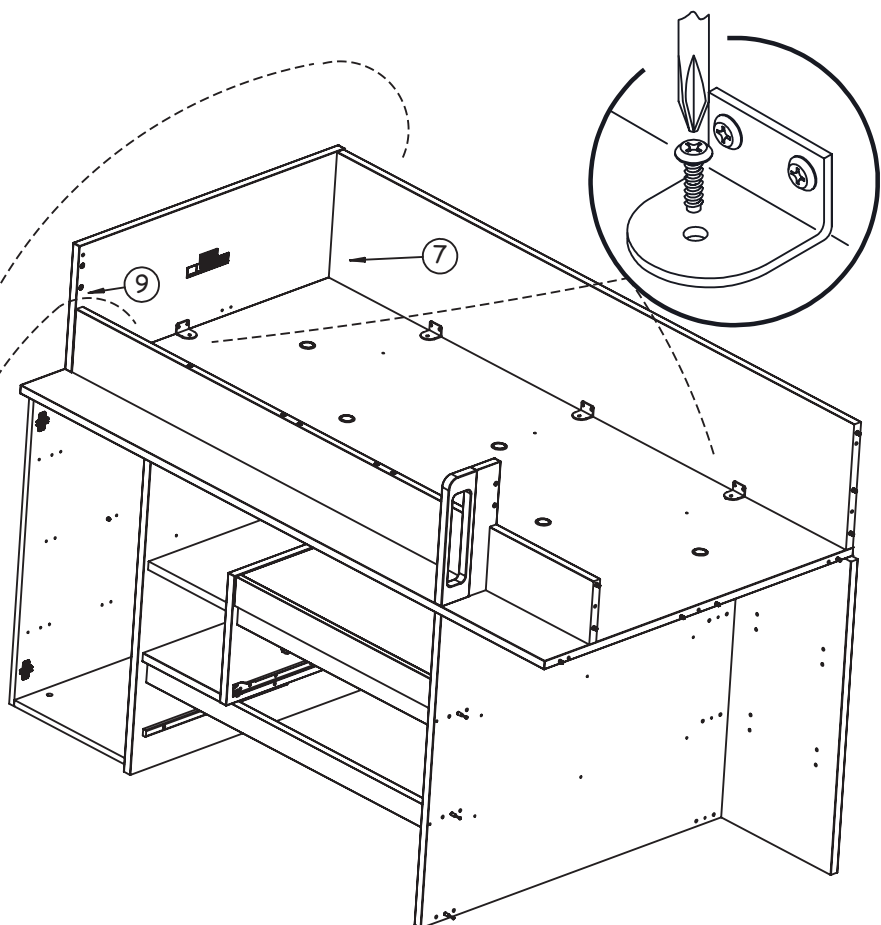
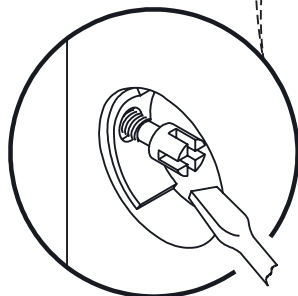
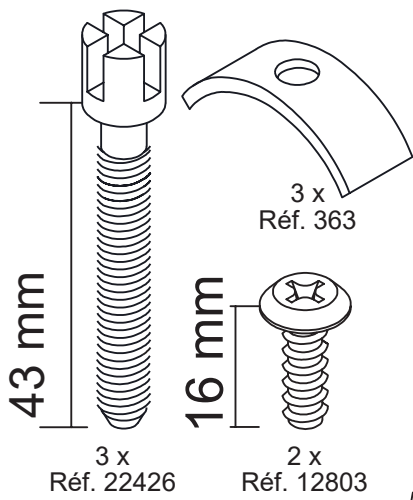

B-39

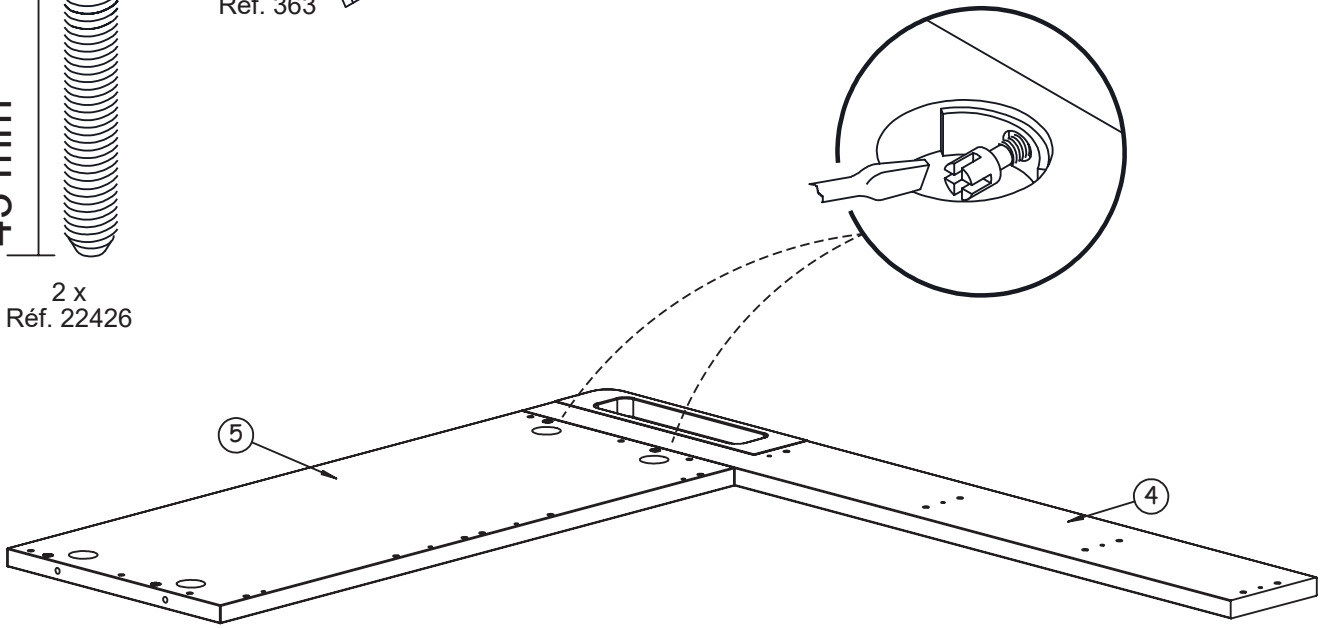
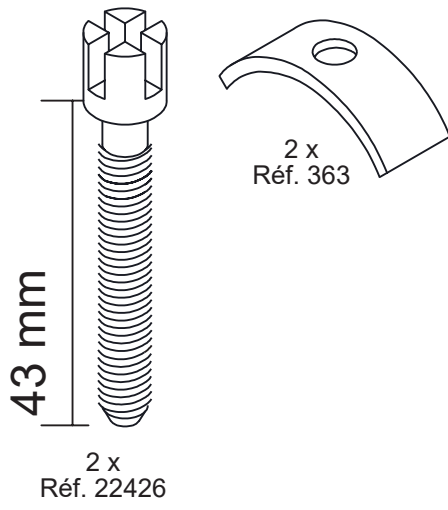

B-40

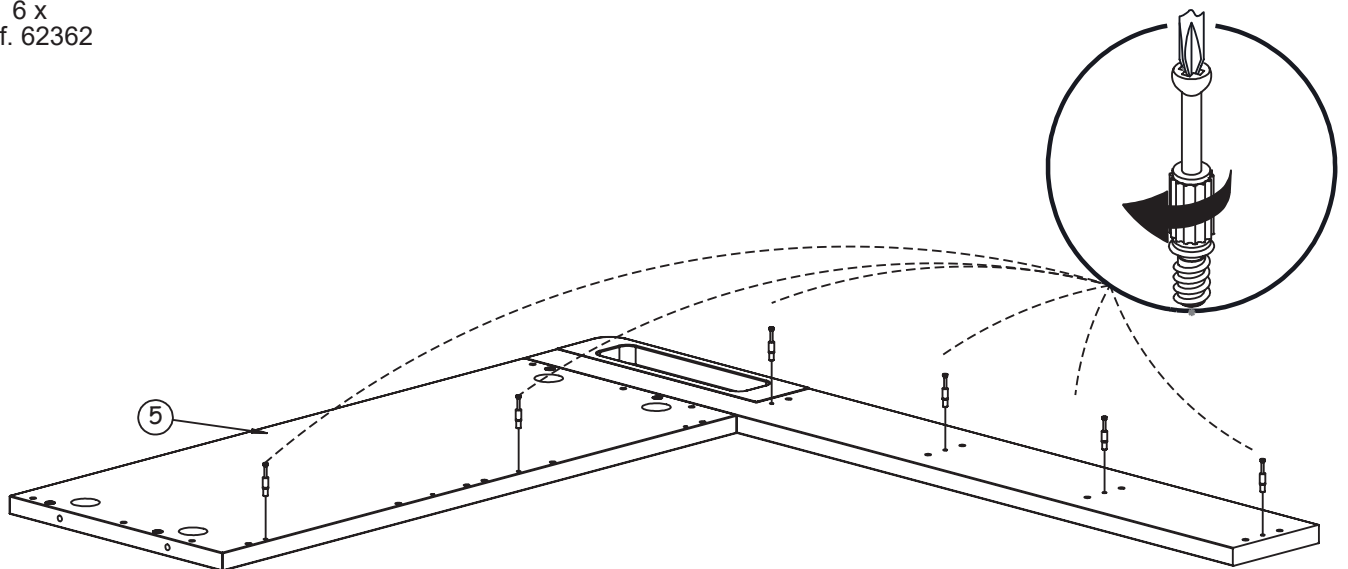
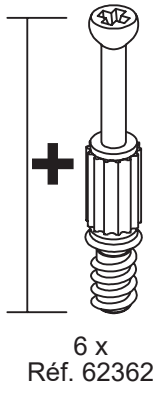

B-41

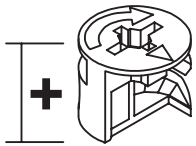

+

3 x
Réf. 62370

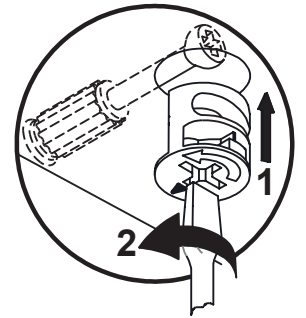
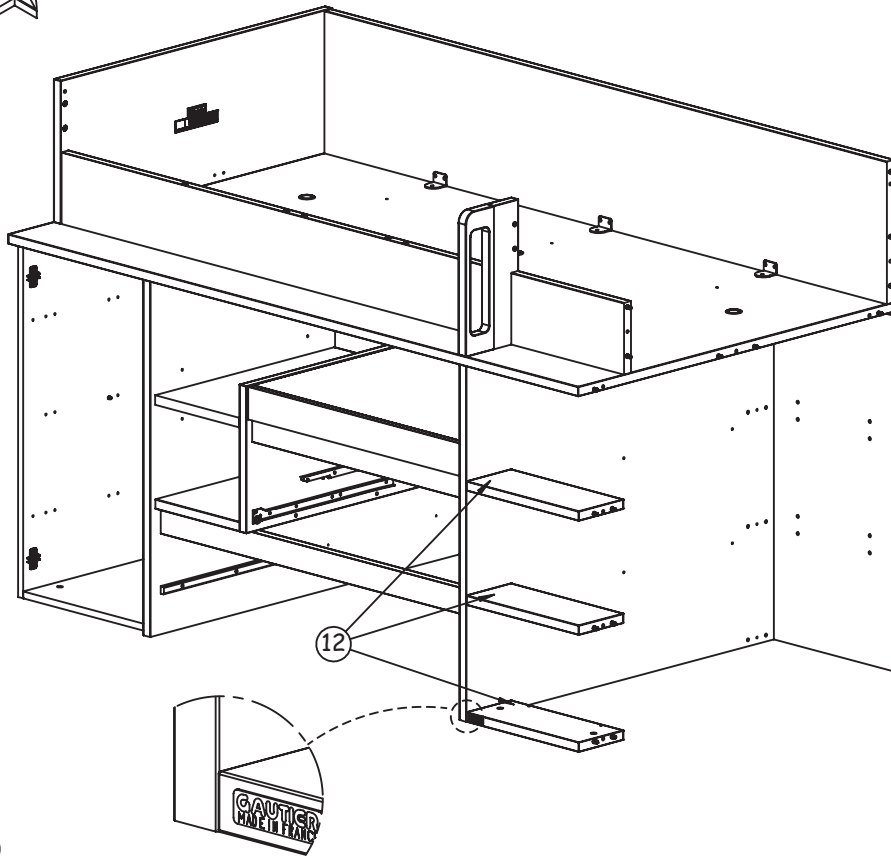

B-42

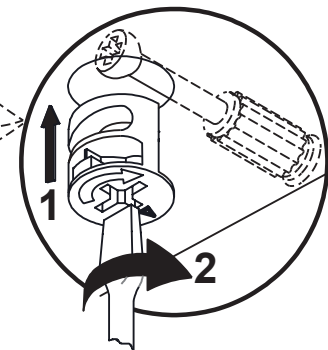
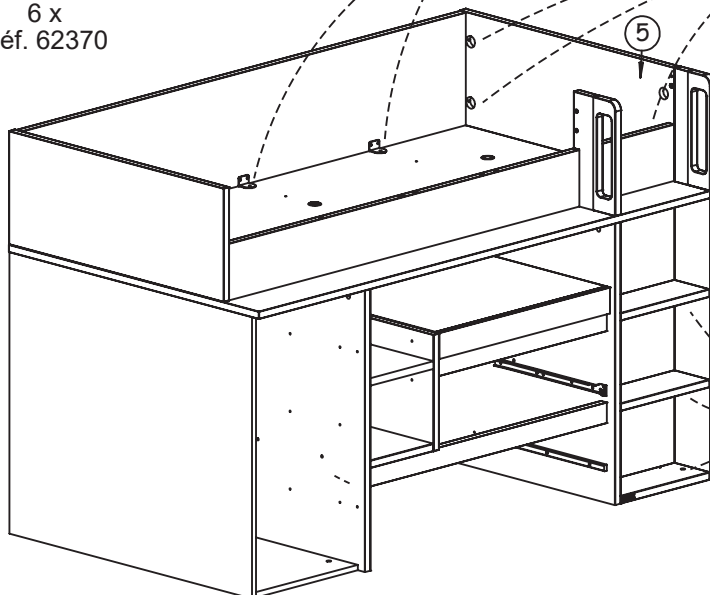
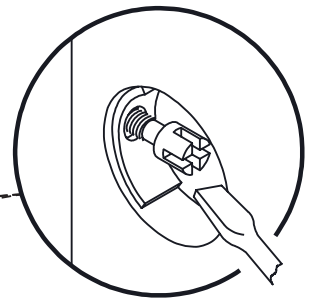
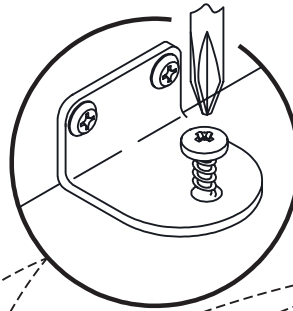
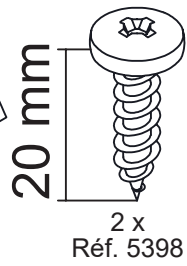
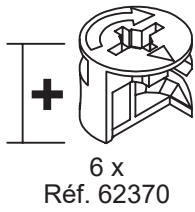
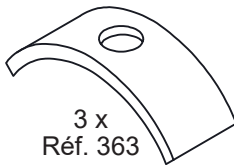
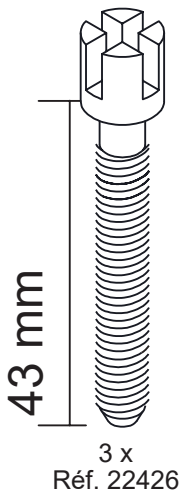

B-43

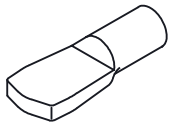

6 x
Réf. 6532

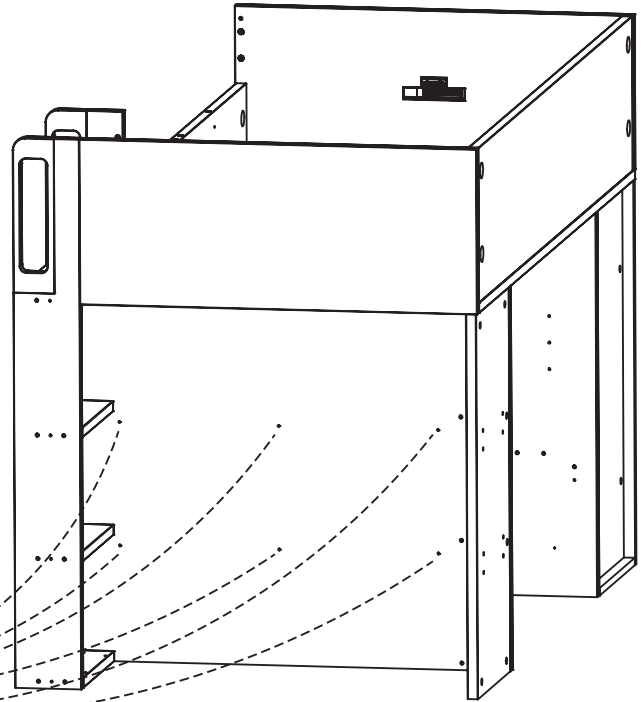
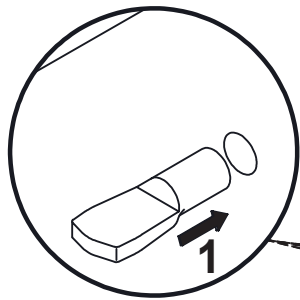

B-44

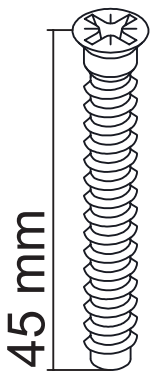

45 mm
2 x
Réf. 44712

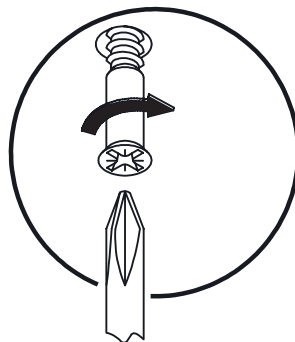
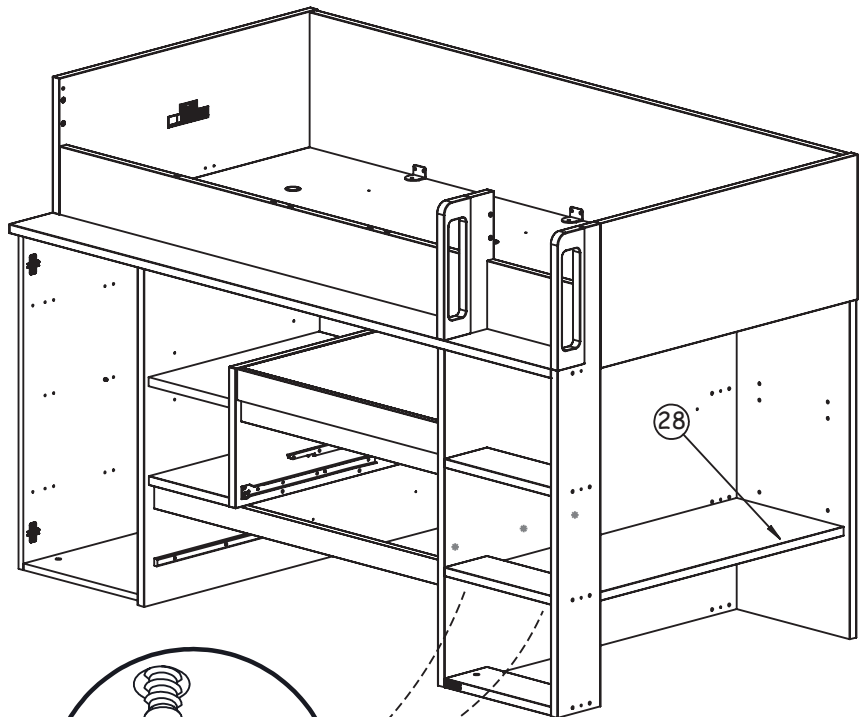
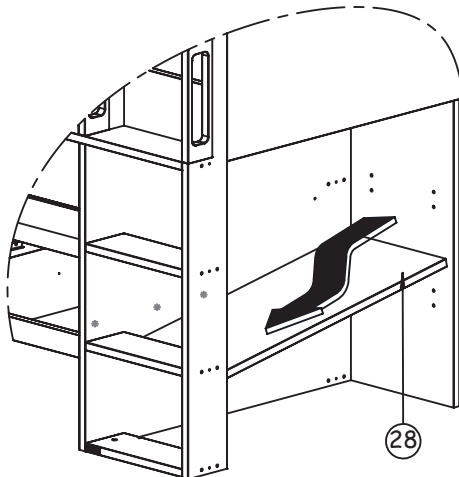

B-45

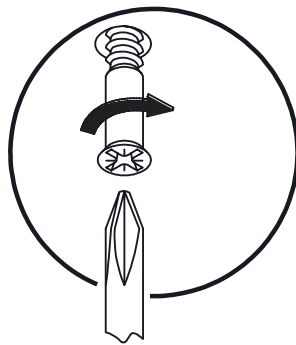
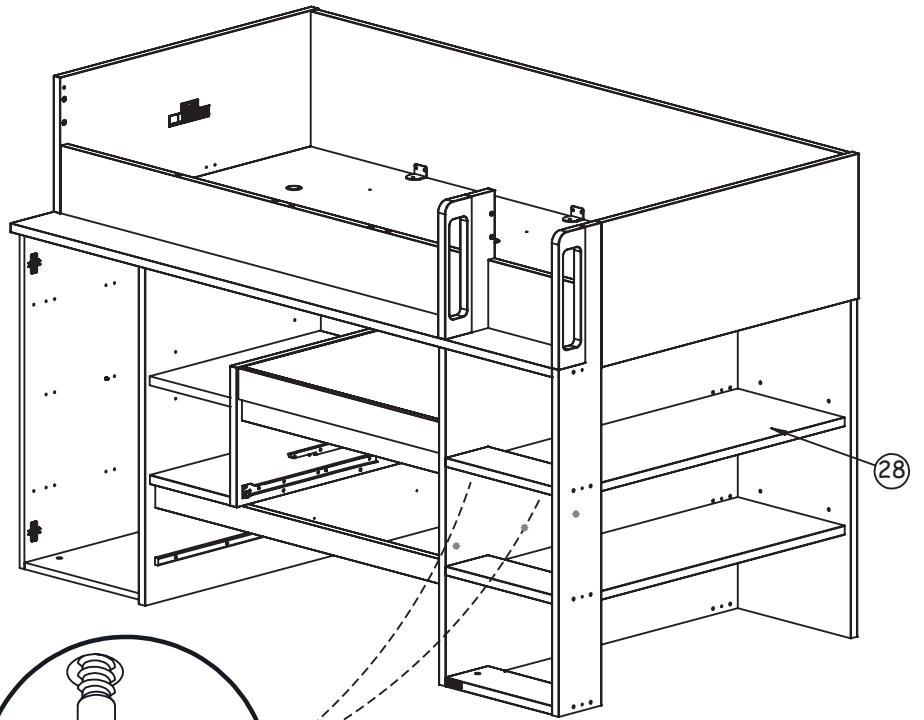
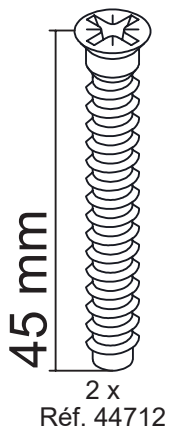

B-46

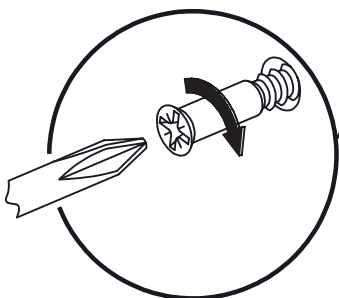
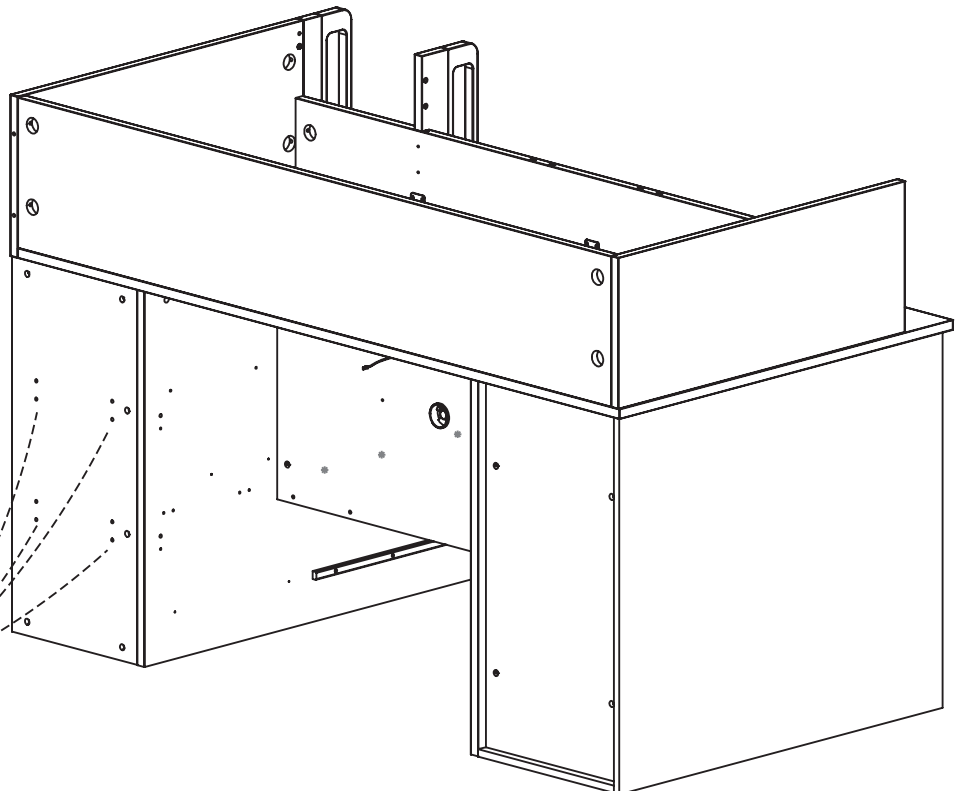
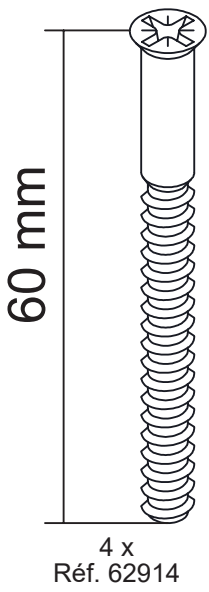

B-47

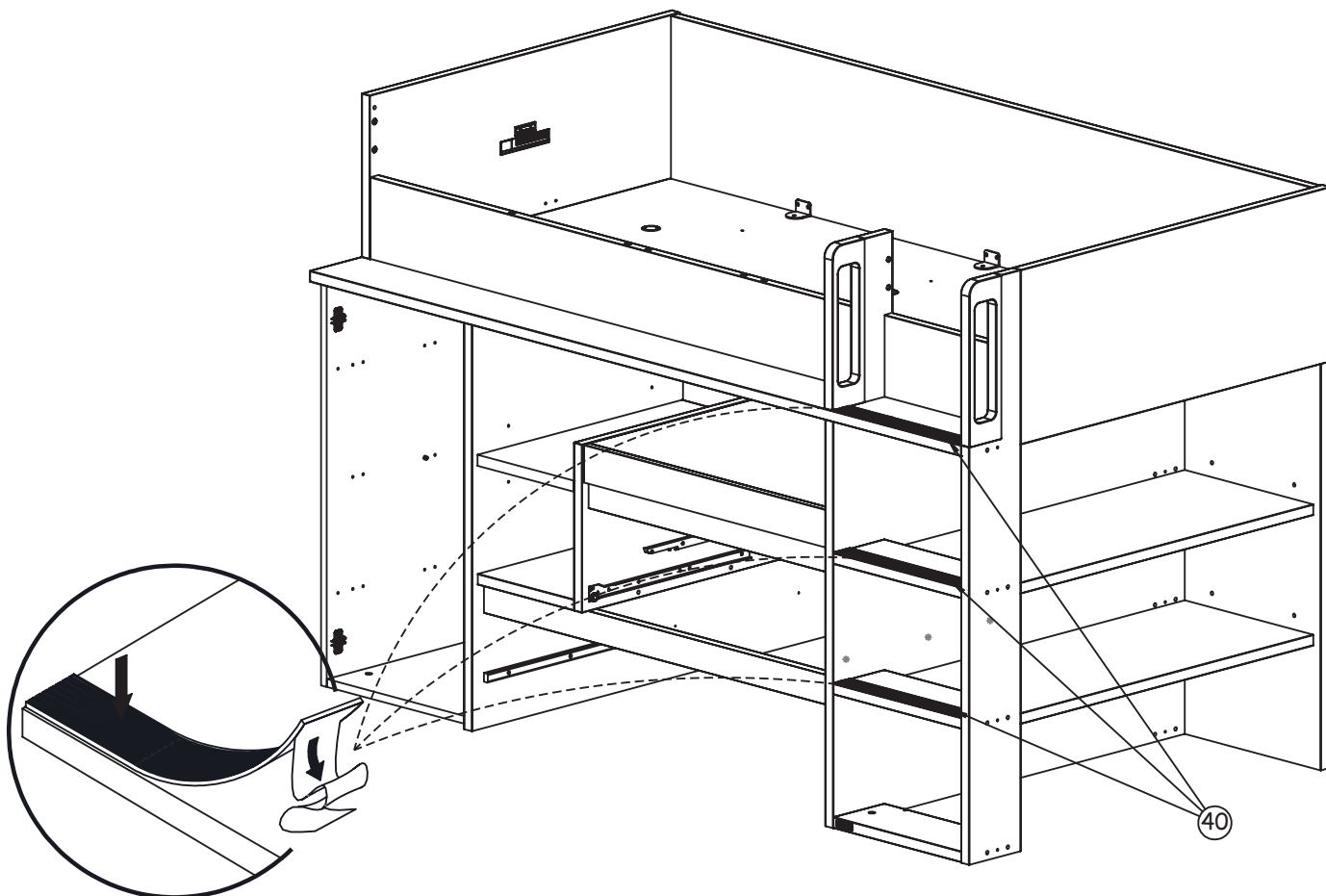

B-48

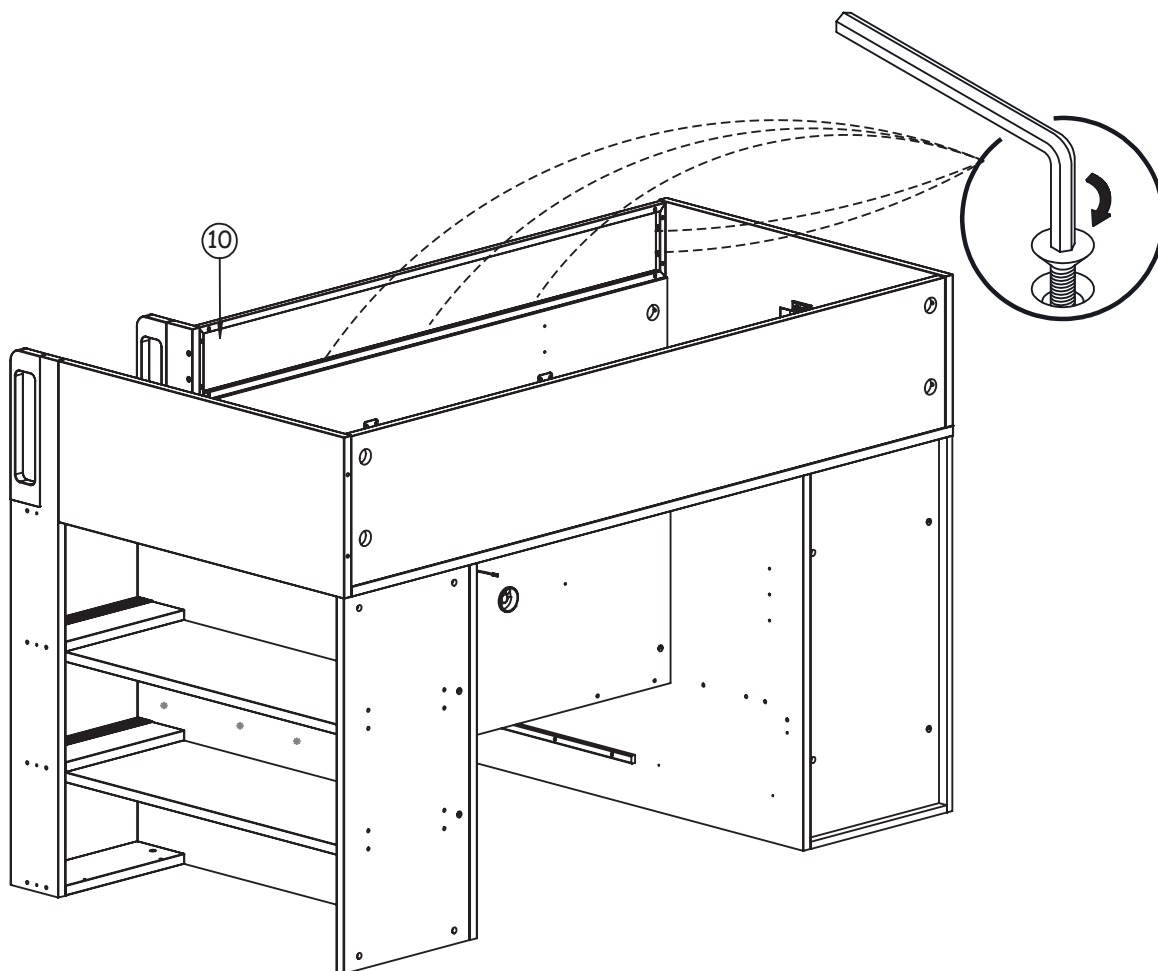
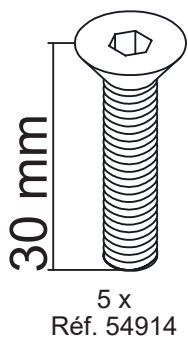

B-49

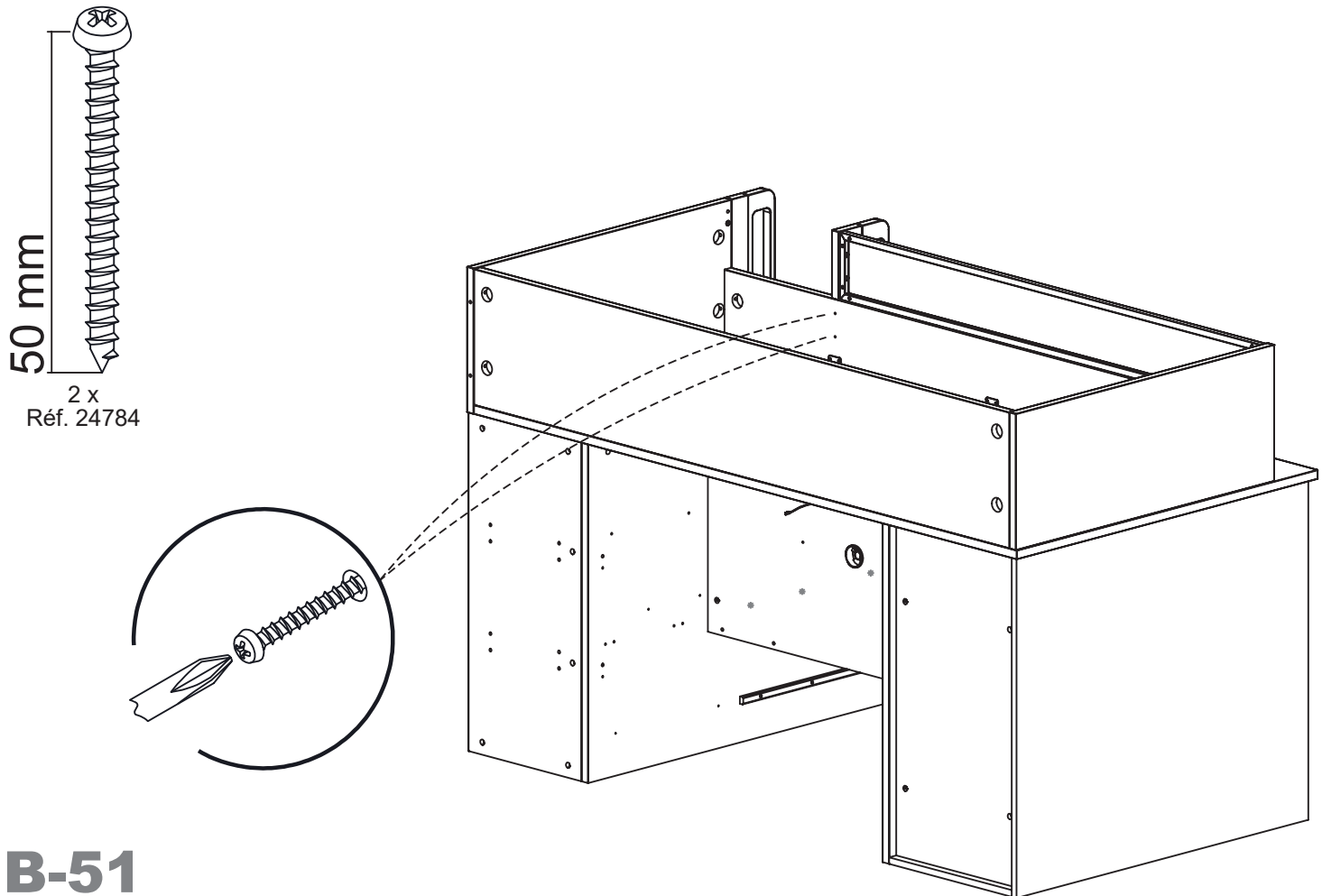
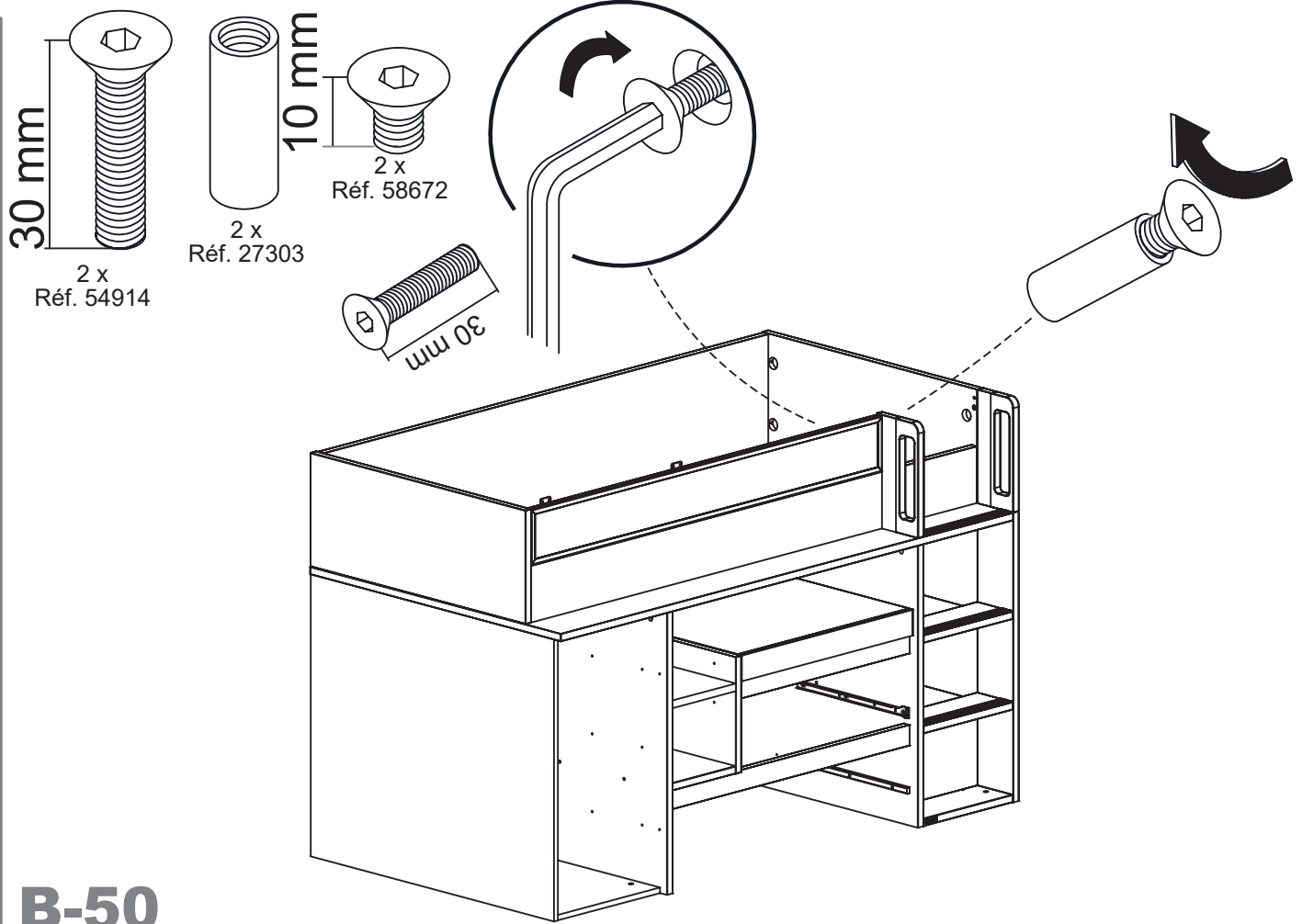

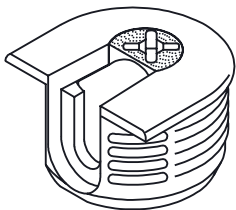

4 x
Réf. 40811

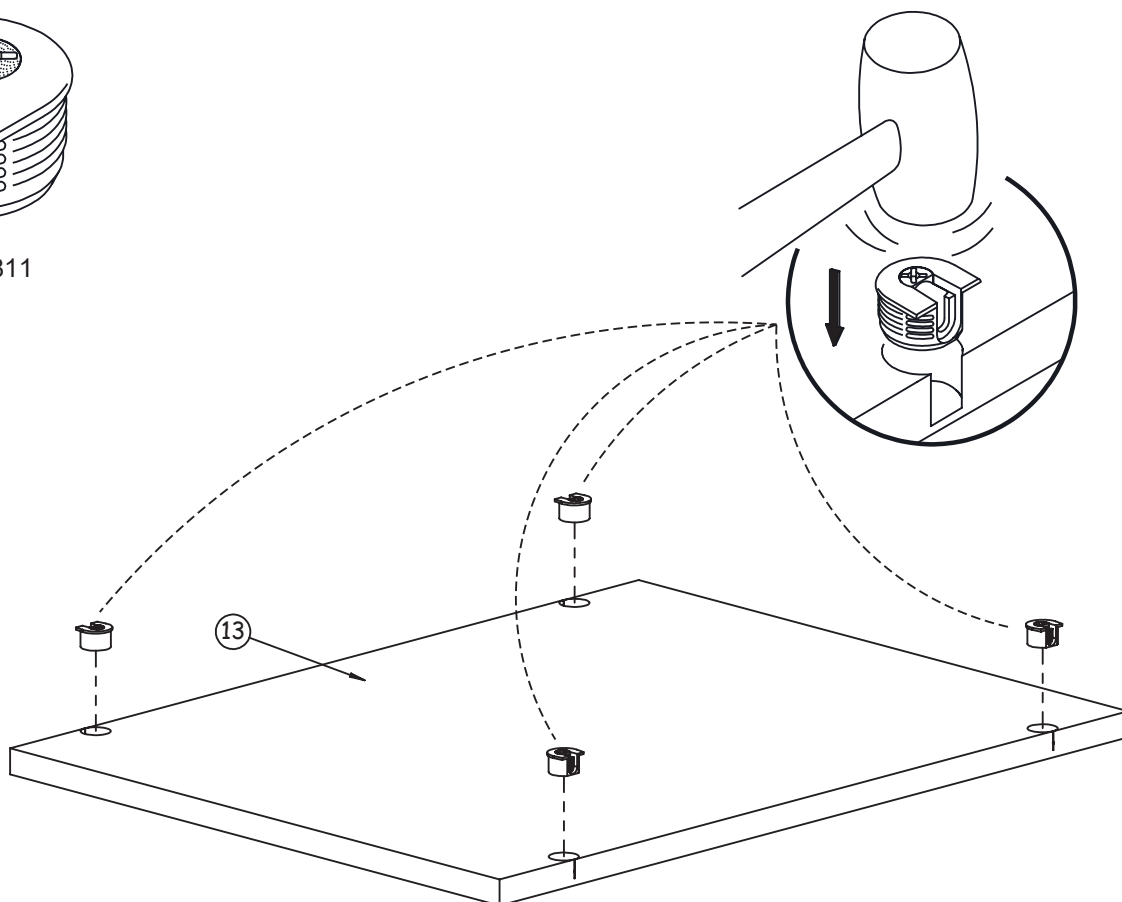

B-52

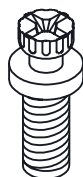

4 x
Réf. 40812

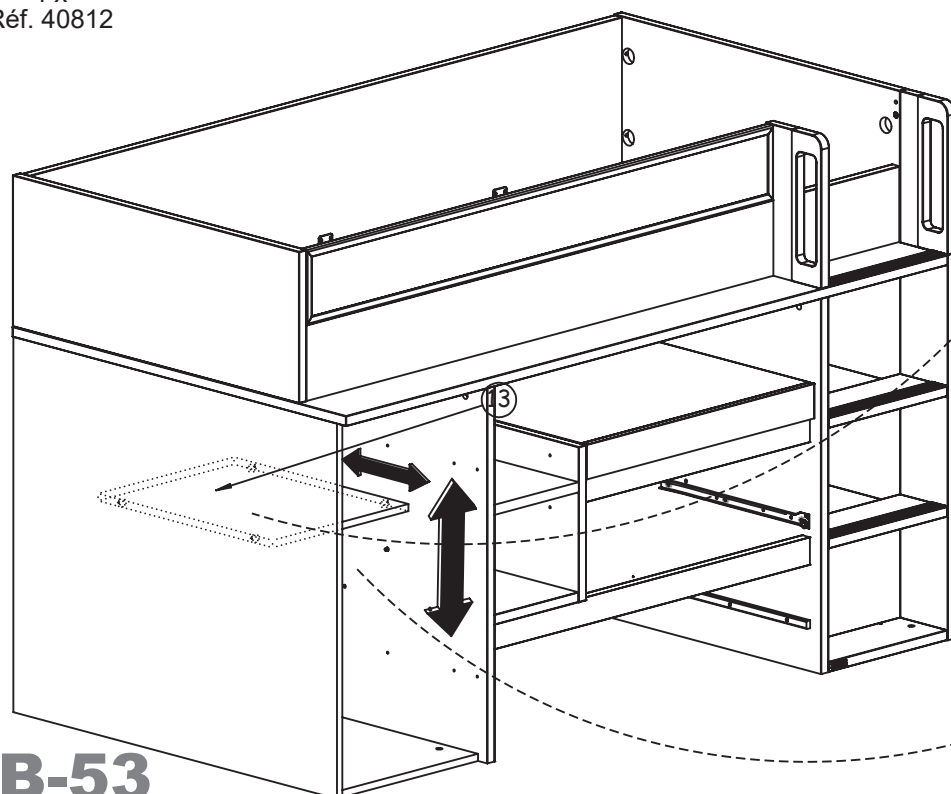

B-53

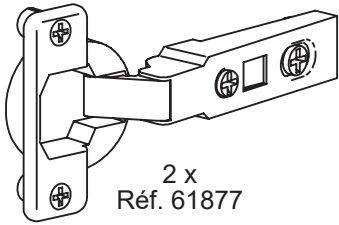

2 x
Réf. 61877

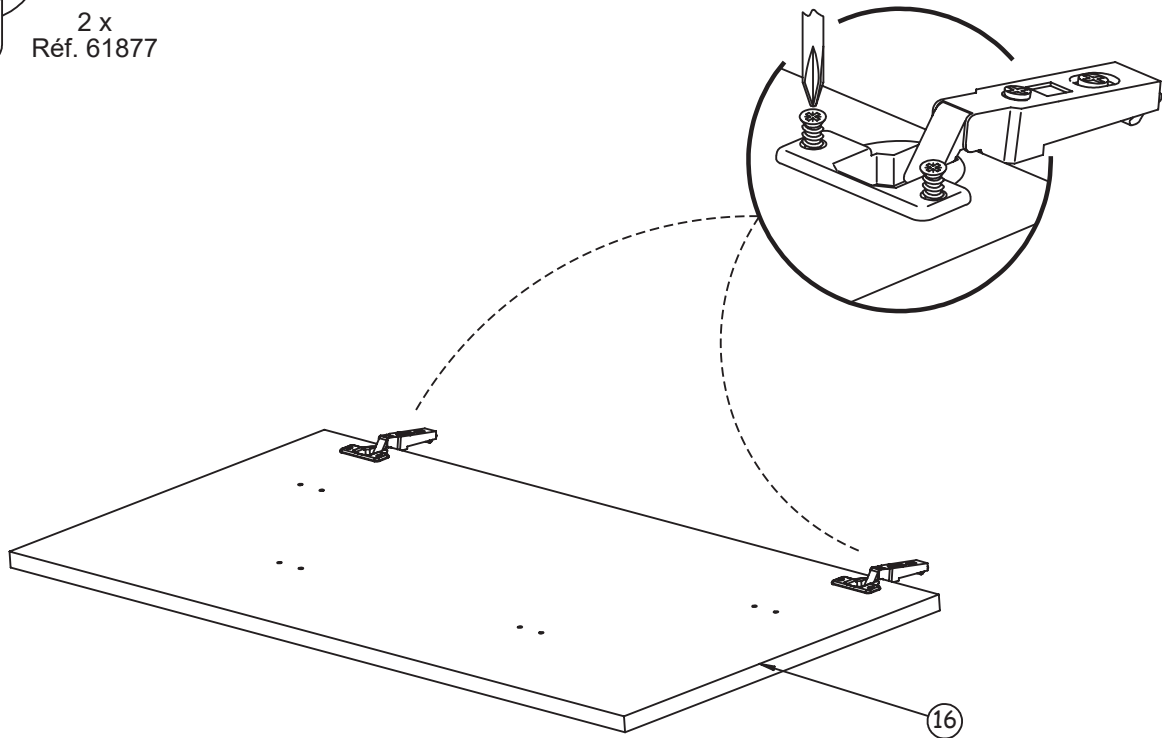

B-54

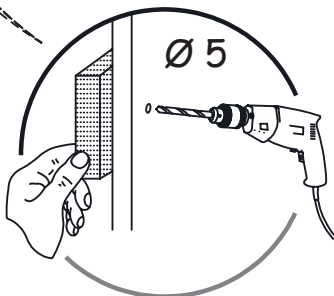
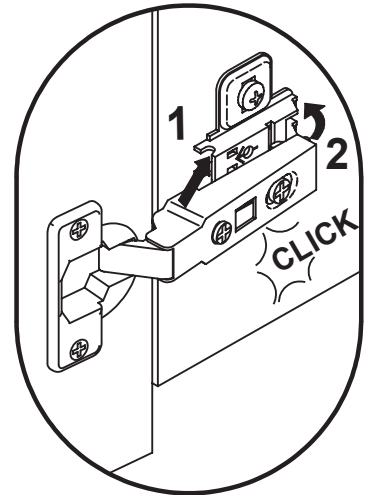
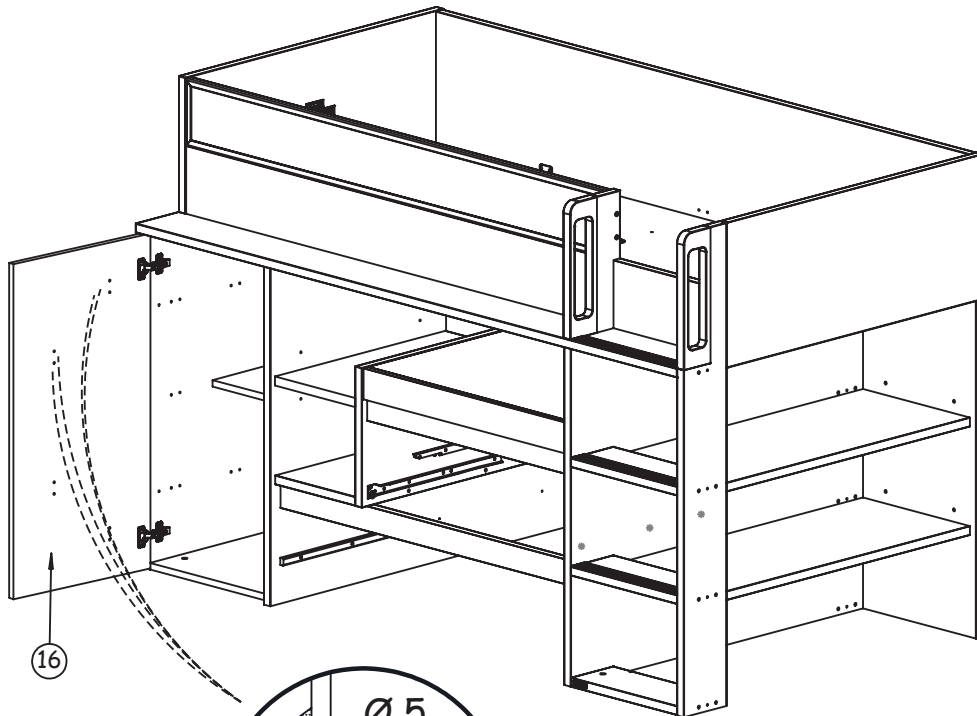

Ø 5

Pour éviter les éclats,
utilisez une cale martyr.
To avoid any splinter,
use a wood wedge.

B-55

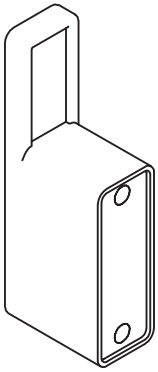

A06-GRIS
2 x Réf. 66651
A26 CHENE
2 x Réf. 66652

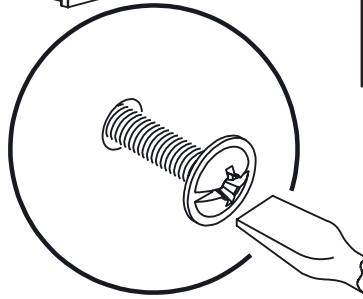
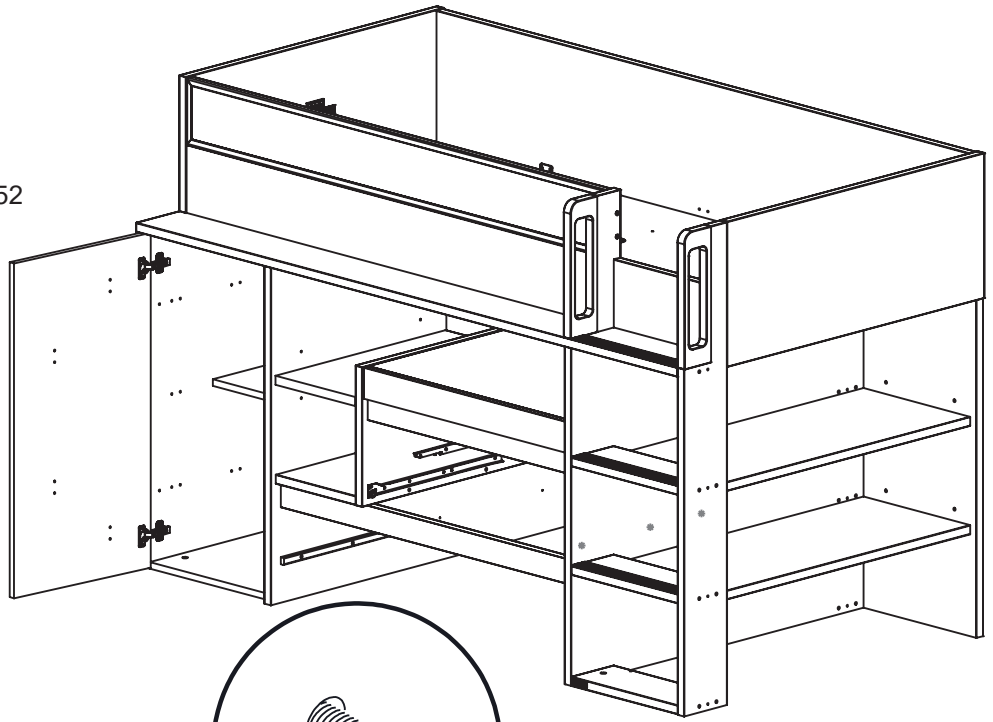
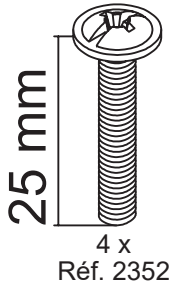

B-56

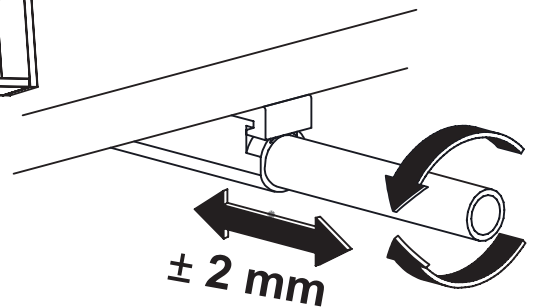
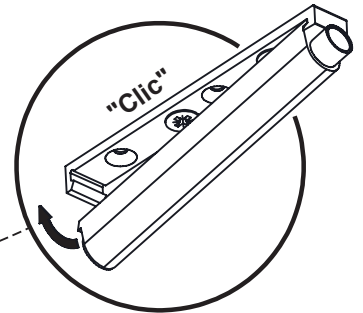
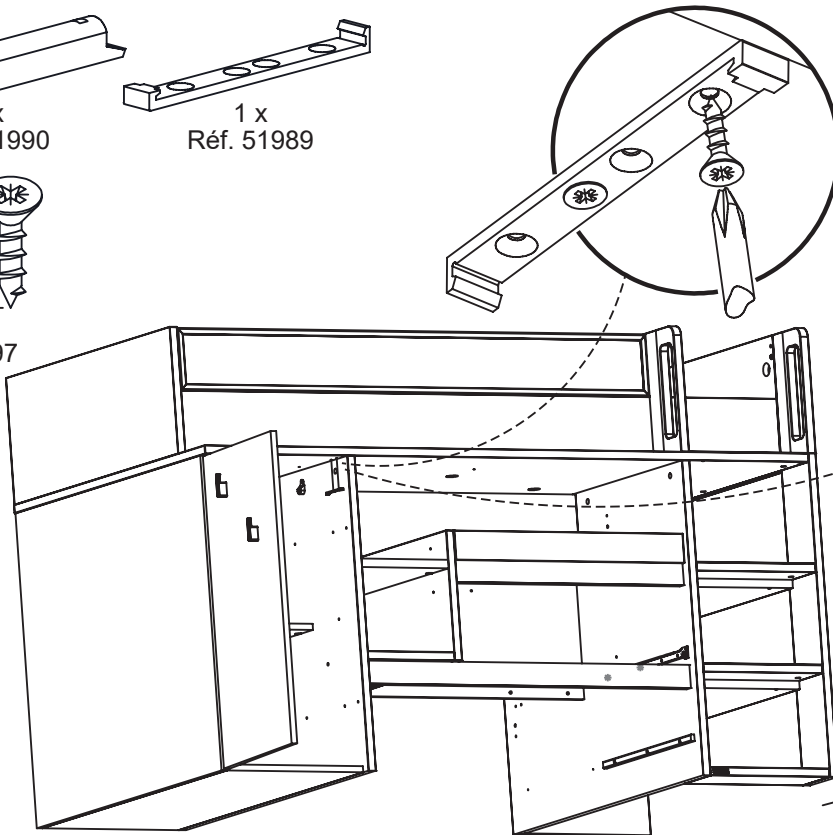
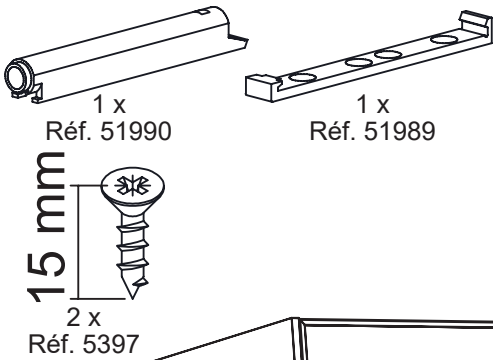

B-57

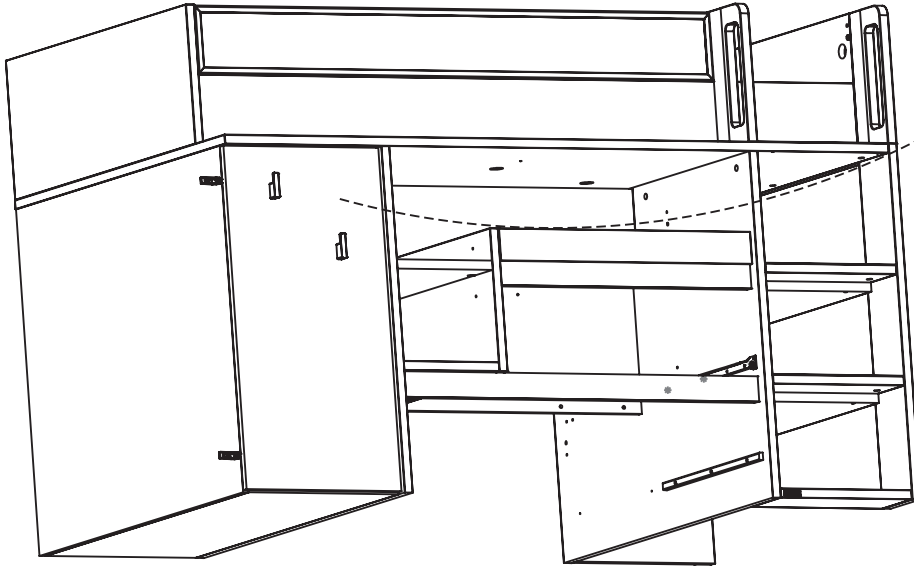
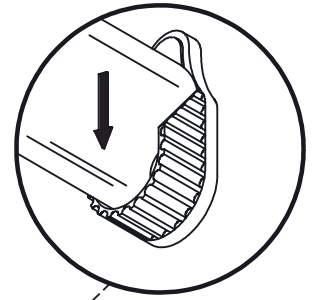
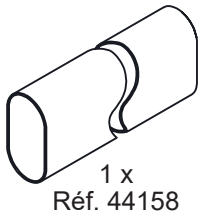

B-58

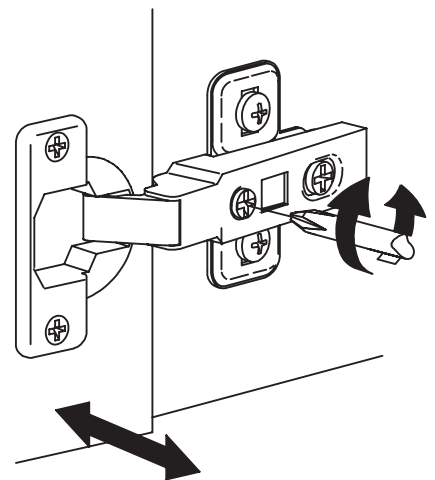
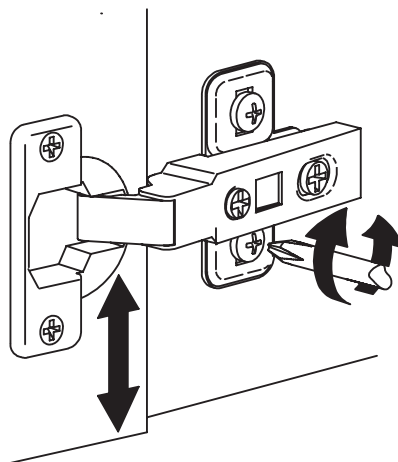
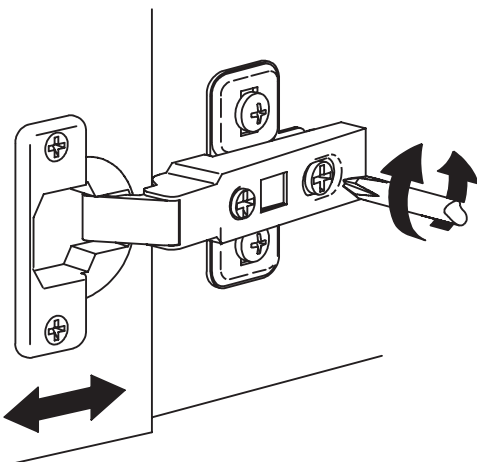
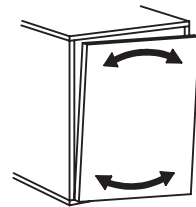
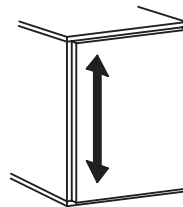
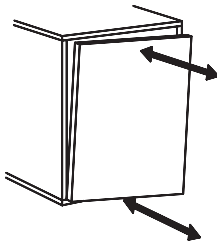

B-59

15 mm
3 x
Réf. 5397

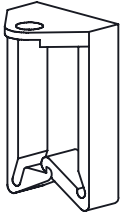

3 x
Réf. 63706

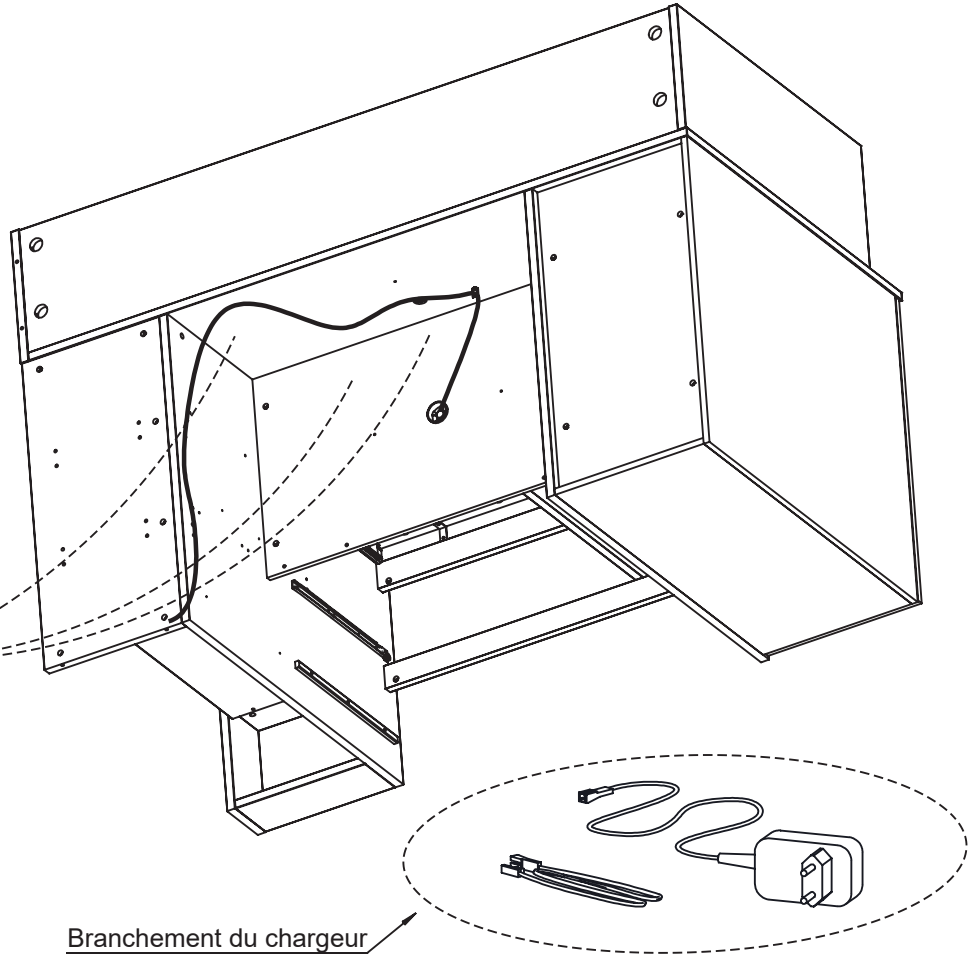
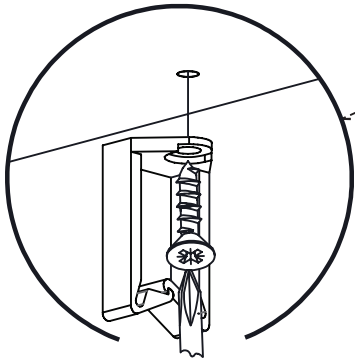

B-60

Branchement du chargeur

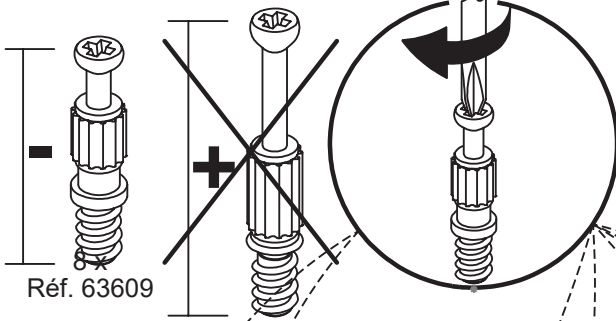

Réf. 63609

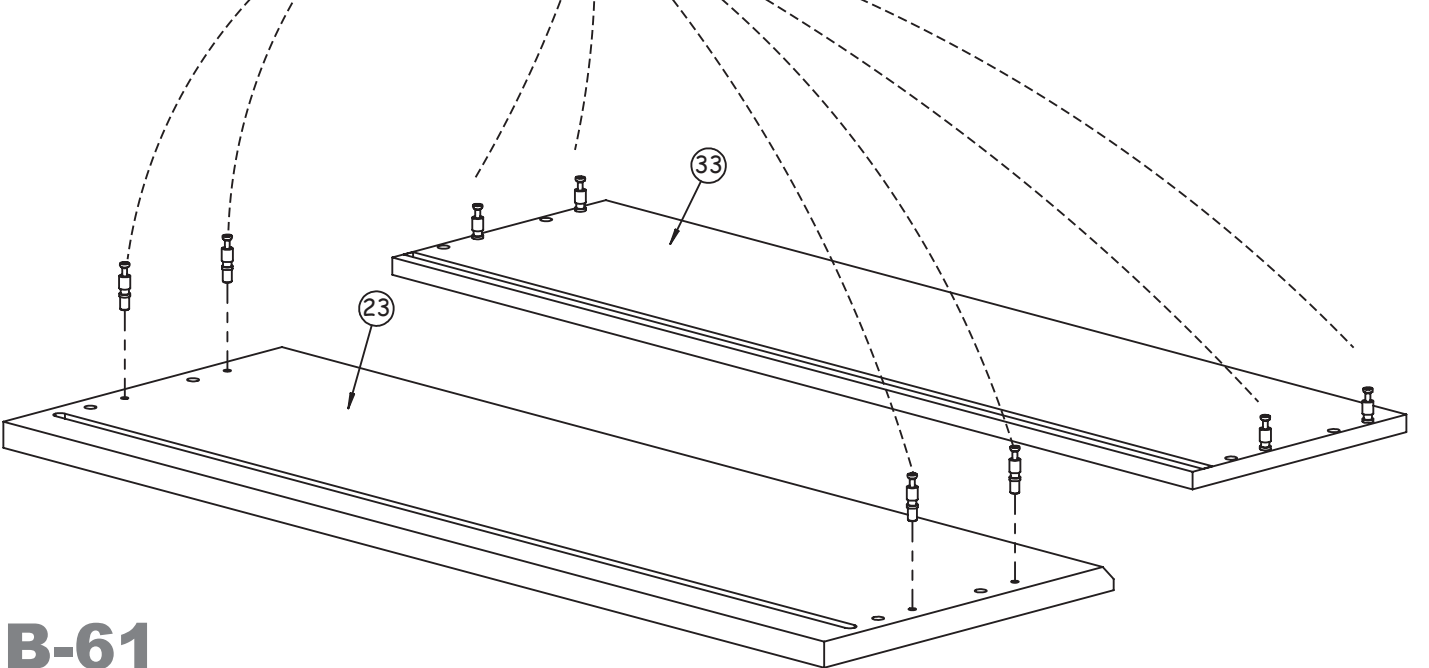
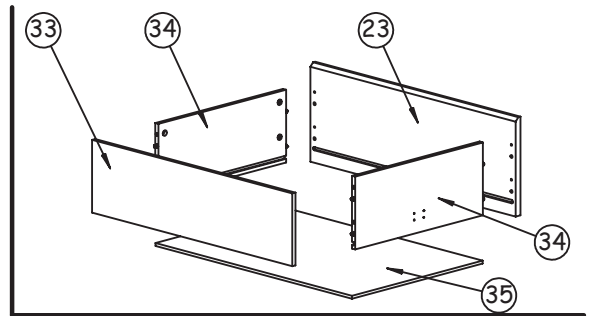

B-61

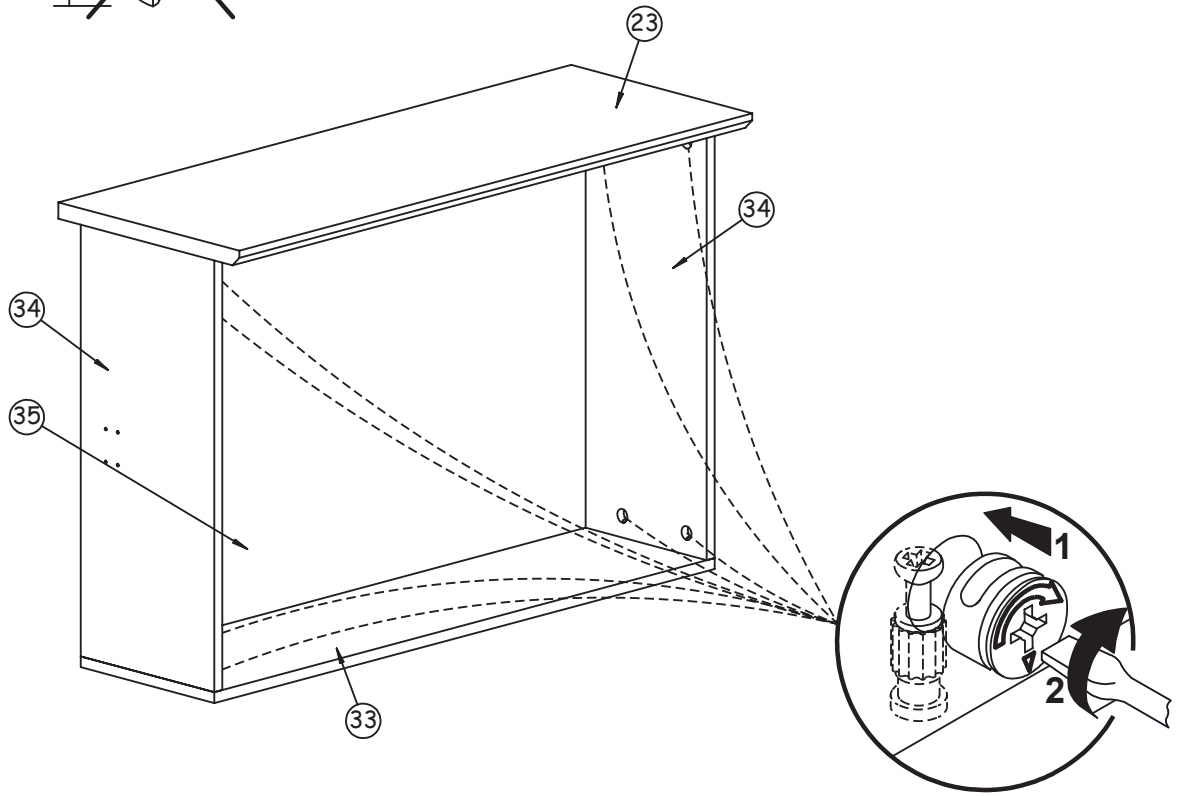
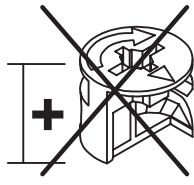
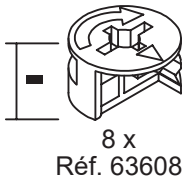

B-62

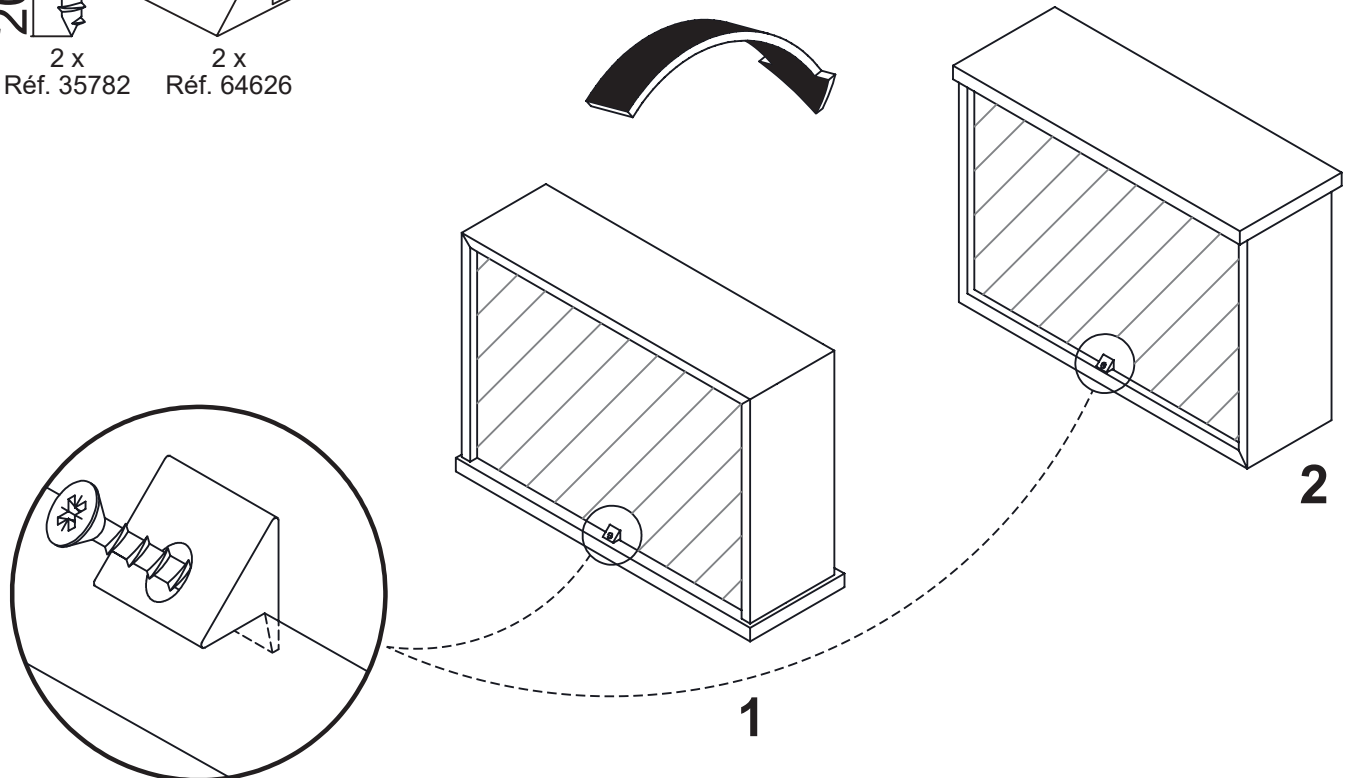
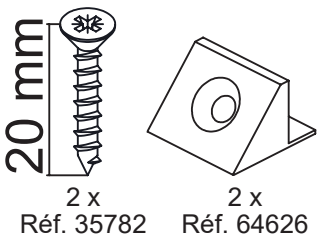

B-63

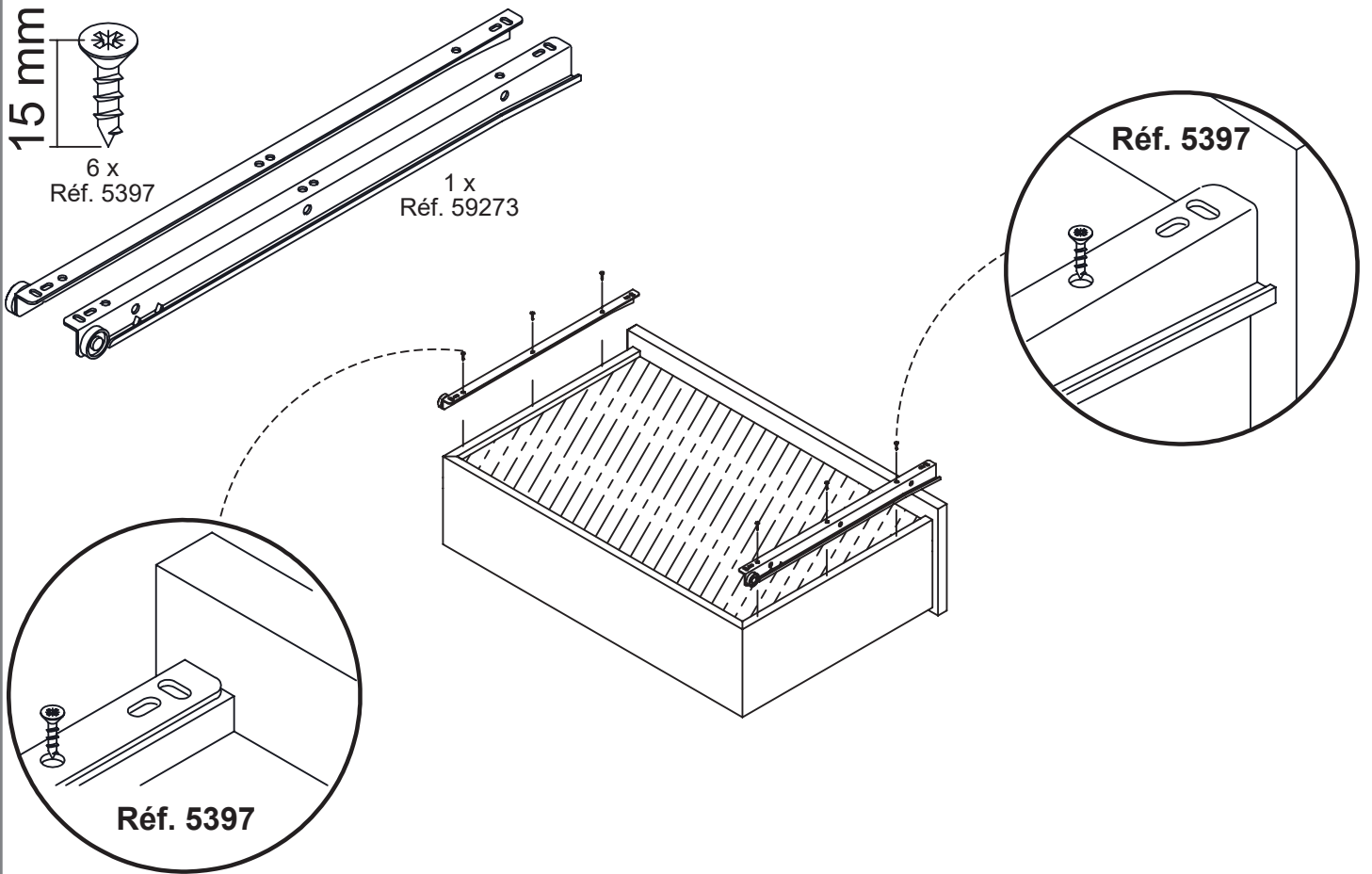

B-64

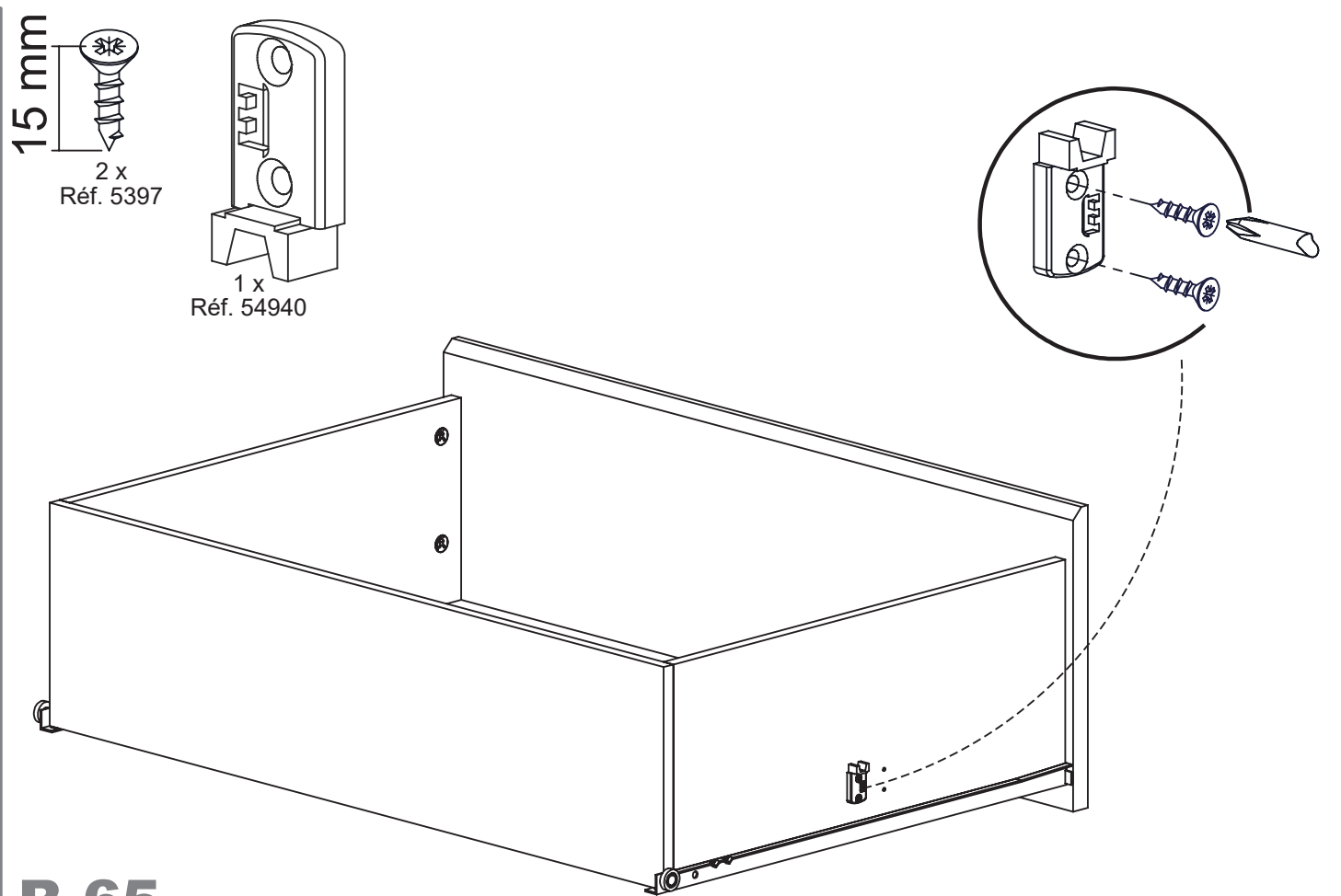

B-65

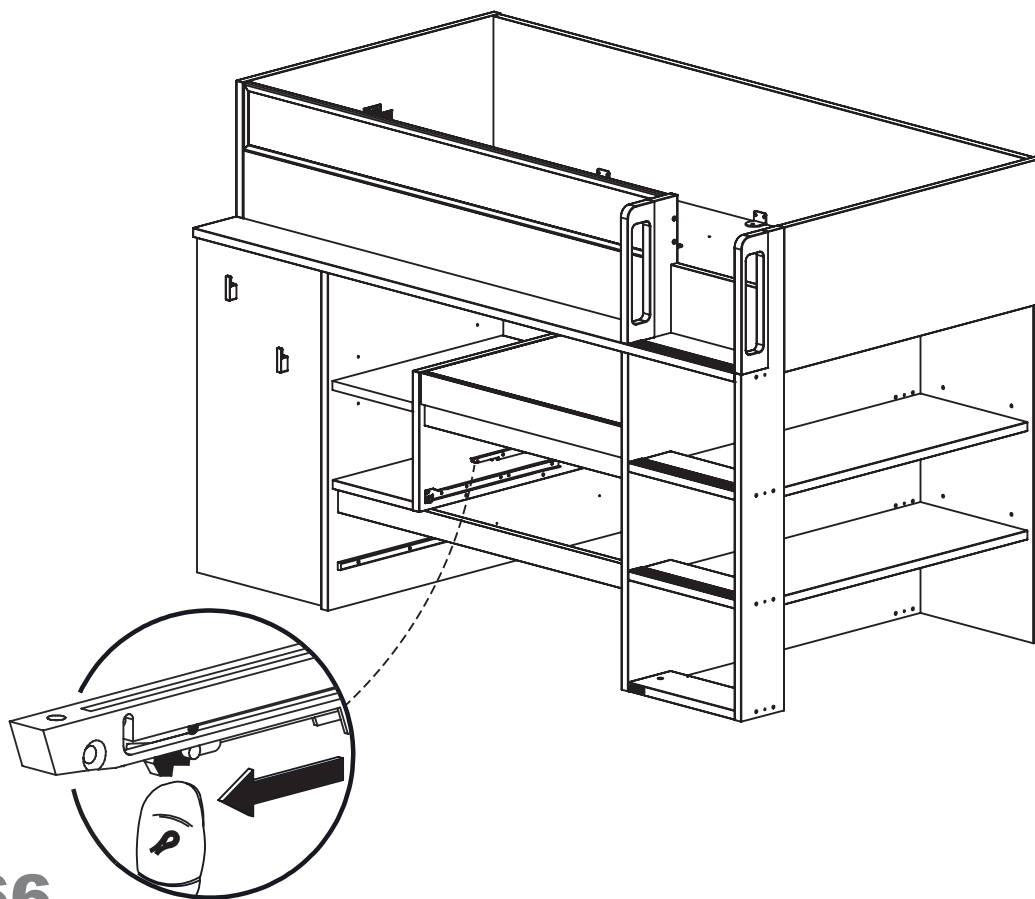

B-66

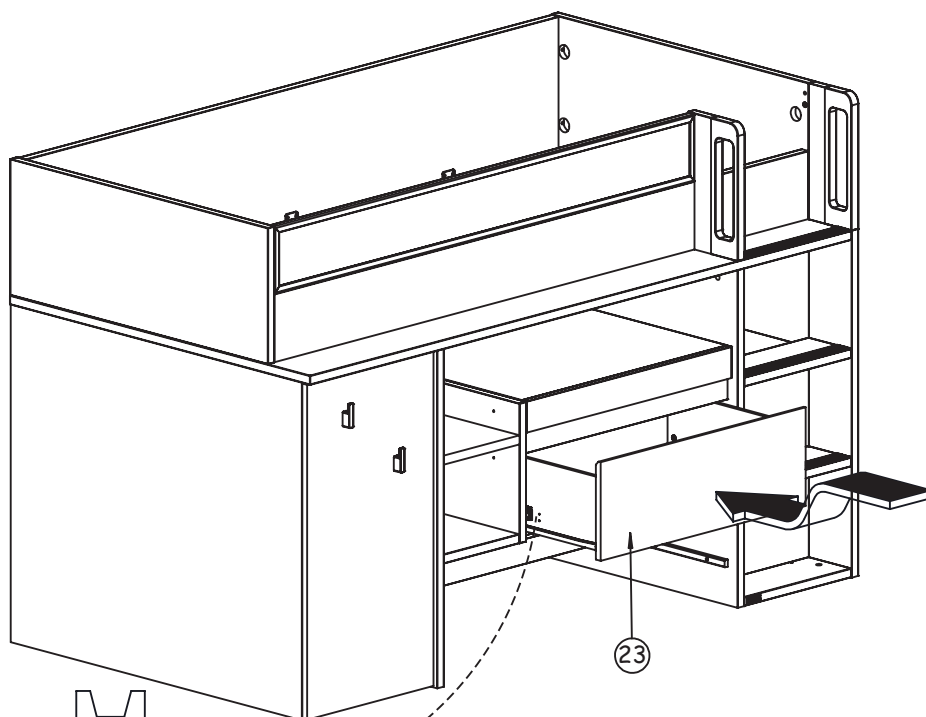

23

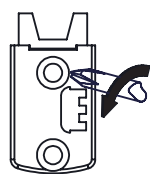

1

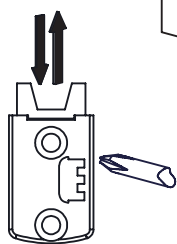

2

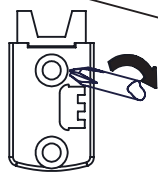

3

B-67

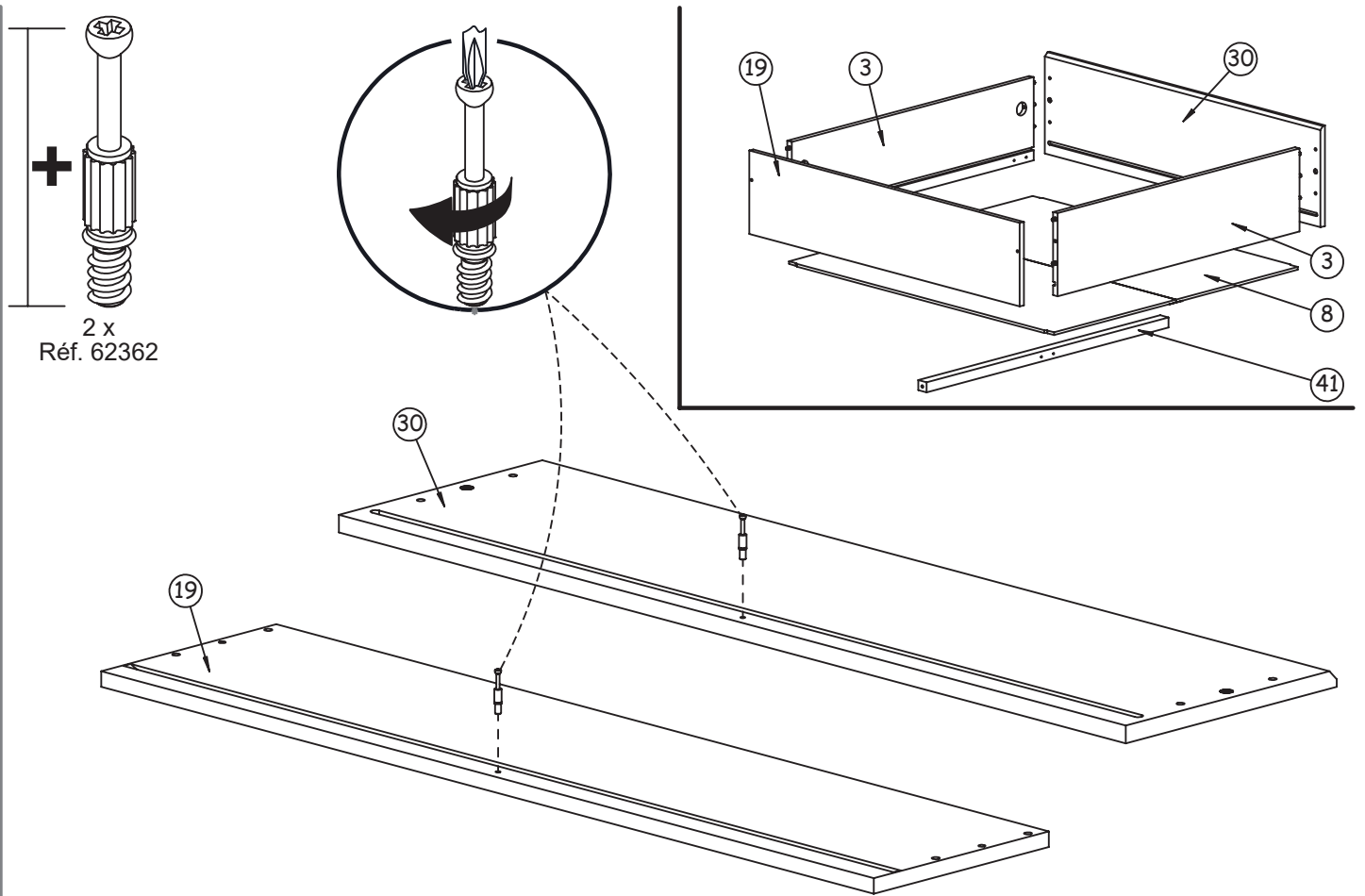

B-68

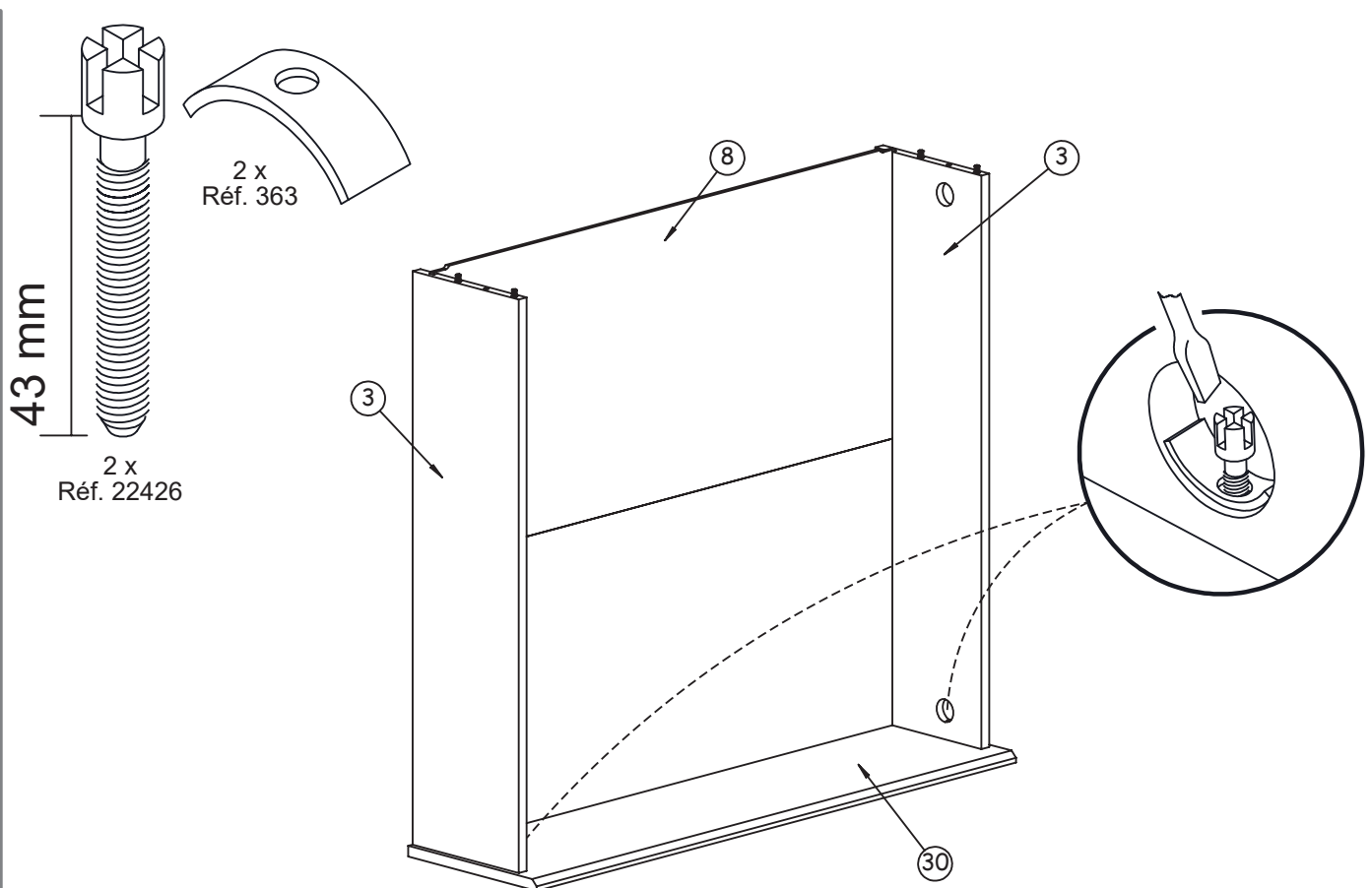

B-69

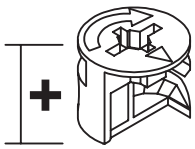

1 x
Réf. 62370

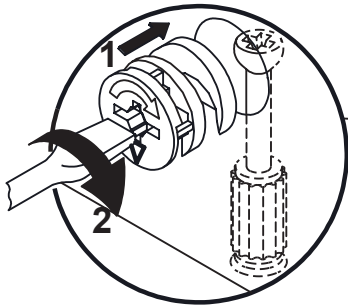
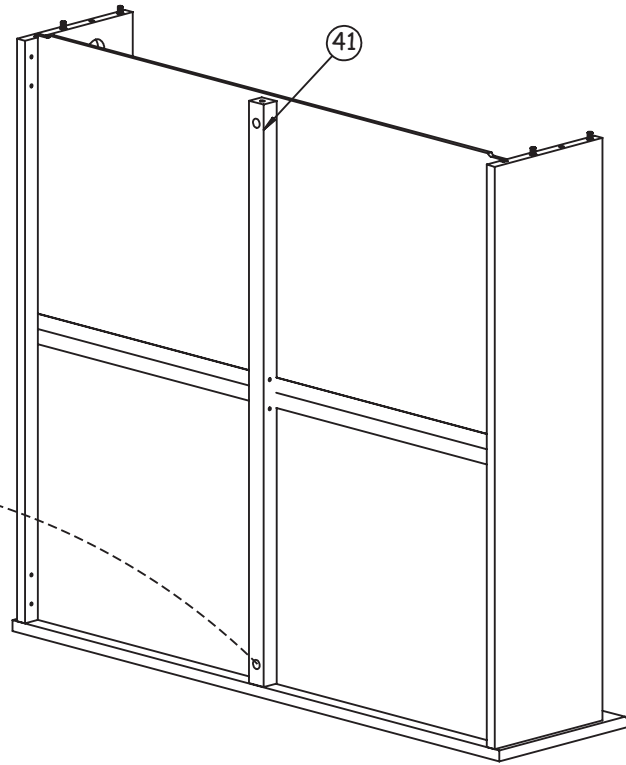

B-70

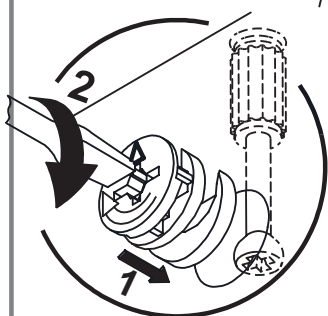
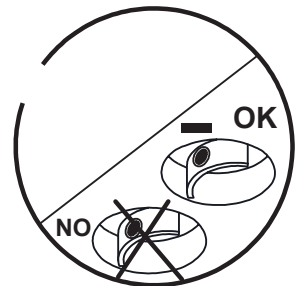
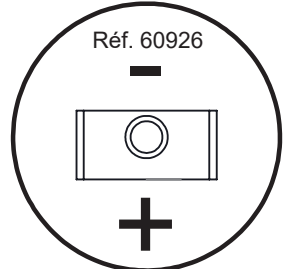
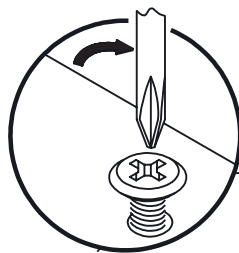
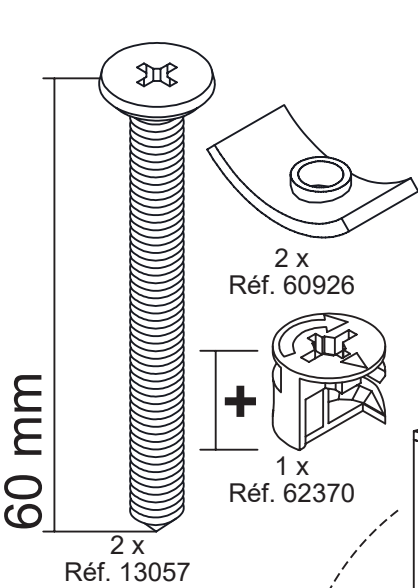

B-71

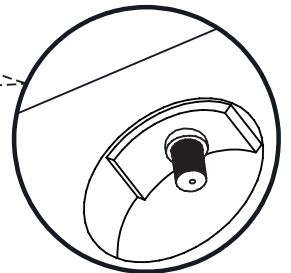
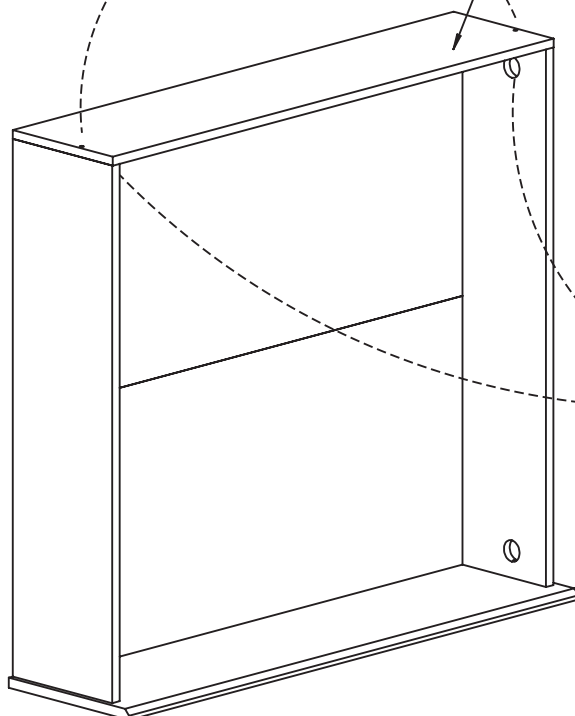

14 mm
10 x
Réf. 7874

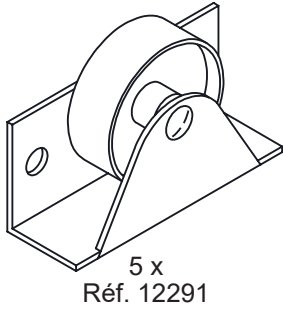

5 x
Réf. 12291



A06-BLANC
2 x Réf. 12805
A26-CHENE
2 x Réf. 60749

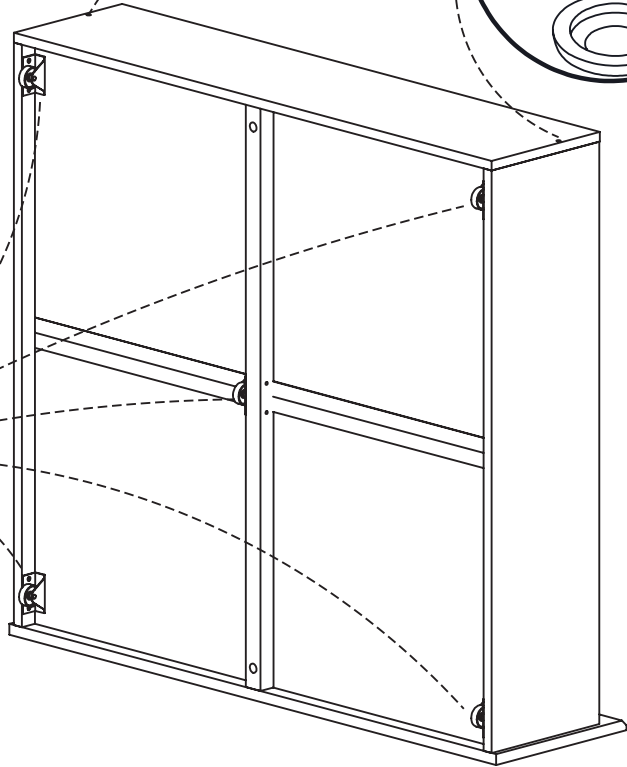
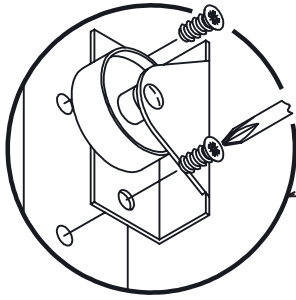
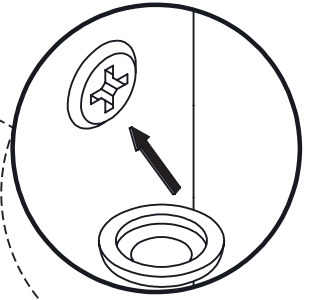

B-72

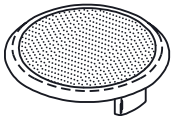

A06-BLANC
4 x Réf. 15118
A06-GRIS
10 x Réf. 58624
A26-CHENE
14 x Réf. 66502

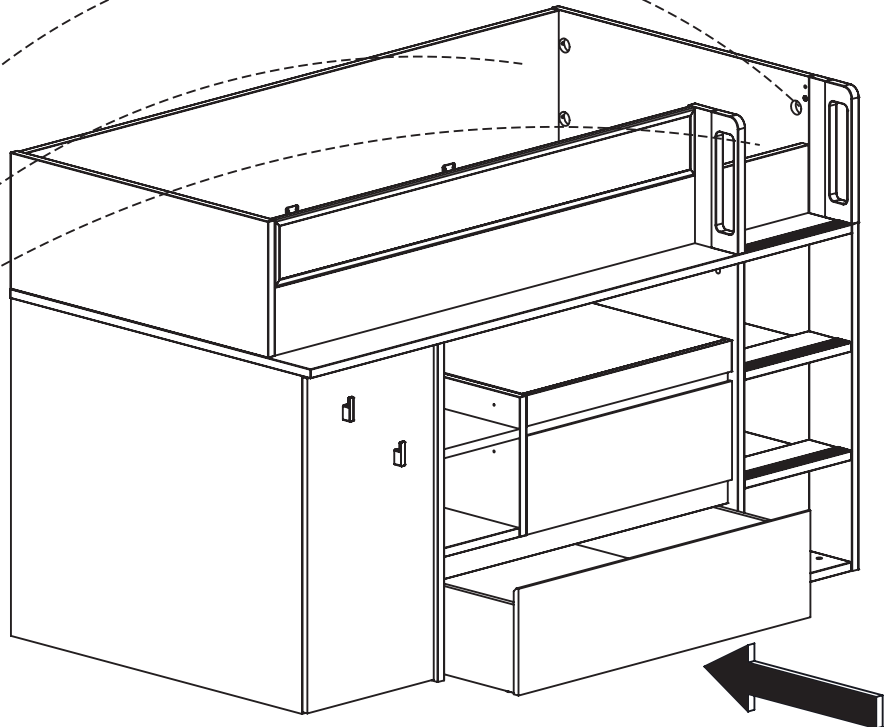
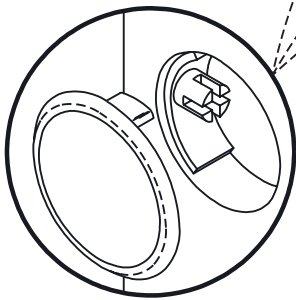

B-73



A06-GRIS
18 x Réf. 58621
A06-BLANC
4 x Réf. 9361

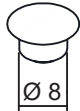

A06-GRIS
28 x Réf. 58626



A26 CHENE
4 x Réf. 66077

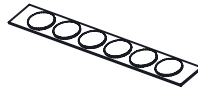

A06-GRIS
4 x Réf. 63760
A06-BLANC
4 x Réf. 60162
A26 CHENE
13 x Réf. 62386

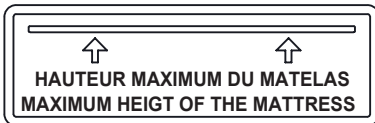

NF EN 747-1 / 2012 + A1:2015
LE COUCHAGE EN HAUTEUR NE CONVIENT PAS A DES
ENFANTS DE MOINS DE 6 ANS
ALL HIGH SLEEPERS ARE NOT RECOMMENDED
FOR CHILDREN UNDER THE AGE OF 6 YEARS

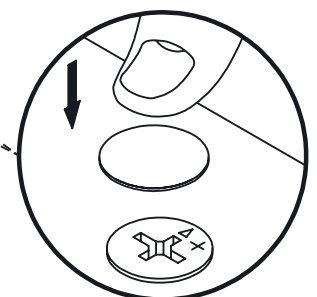
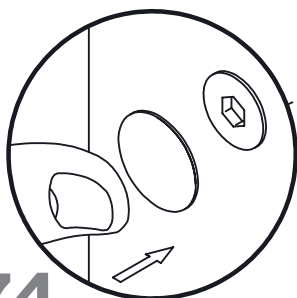
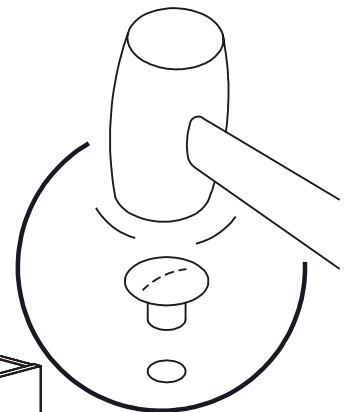
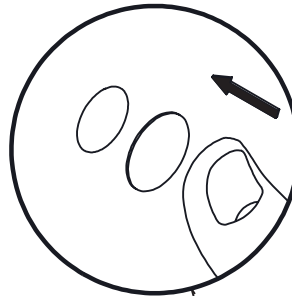
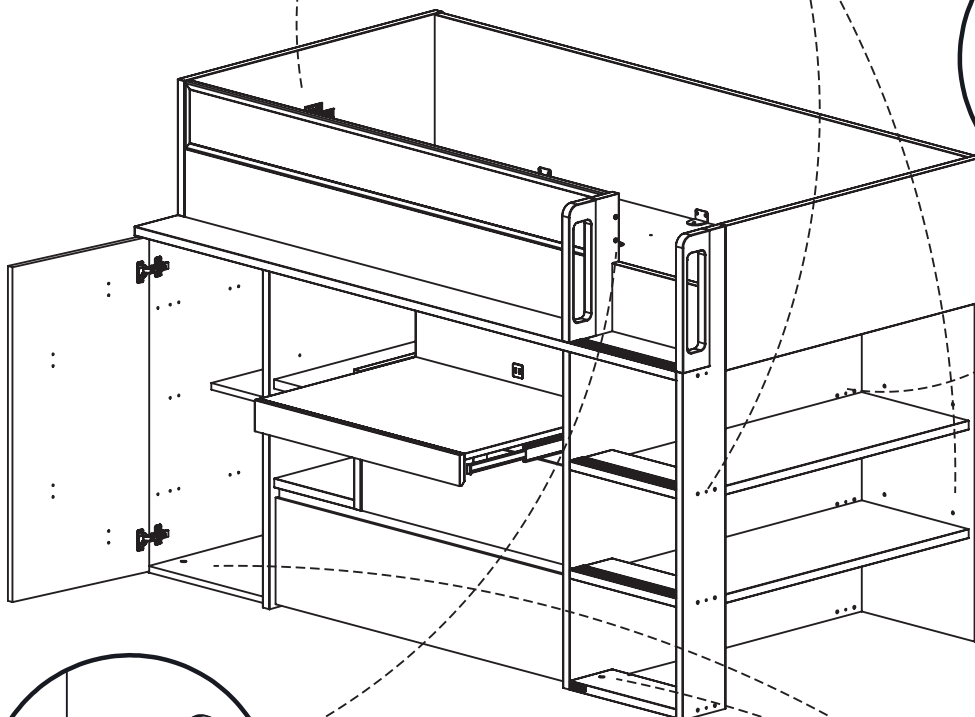

B-74

**INSTRUCTIONS DE RECYCLAGE - RECYCLING INSTRUCTIONS - INSTRUCCIONES DE RECICLAJE
 RECYCLING INSTRUCTIES - RECYCLING-ANWEISUNGEN - ISTRUZIONI DI RICICLAGGIO
 ИНСТРУКЦИЯ ПО УТИЛИЗАЦИИ - INSTRUÇÕES DE RECICLAGEM**

- FR** Lors de l'élimination de votre mobilier usagé, les composants en bois, en plastique et en métal peuvent être séparés et être dirigés en déchetterie vers les contenants appropriés pour favoriser leur valorisation. Toutefois, si votre déchetterie est équipée d'une benne "meuble", vous pouvez déposer votre mobilier en l'état; l'éco-organisme gestionnaire de la filière DEA (www.eco-mobilier.fr) prendra en charge les opérations nécessaires à la valorisation optimale de celui-ci. Enfin n'oubliez pas que vous pouvez prolonger la durée de vie de vos produits usagés en contactant les associations caritatives de votre région.
- GB** When your furniture is no longer of use, its wood, plastic and metal components can be separated out and placed in the appropriate bins to be recycled. But remember that you may be able to extend the useful life of used furniture by passing it on to a charitable association in your neighbourhood.
- ES** Cuando elimine su mobiliario usado, los componentes de madera, plástico y metal pueden separarse y llevarse al vertedero y tirarse en los contenedores apropiados para su reciclaje. No obstante, no olvide que podrá prolongar la duración de vida de sus productos usados si se pone en contacto con las asociaciones de voluntariado social de su región.
- NL** Houten, plastic en metalen onderdelen van uw afgedankte meubels kunt u in gescheiden vorm aanbieden bij een afvalverzamelpunt en in de daarvoor bestemde containers werpen zodat ze opnieuw gebruikt kunnen worden. U kunt natuurlijk ook nog een tweede leven geven aan uw meubels door contact op te nemen met een liefdadigheidsinstelling bij u in de buurt.
- DE** Die Holz-, Kunststoff und Metallteile Ihrer Altmöbel können getrennt und in einem Wertstoffhof dem entsprechenden Recycling zugeführt werden. Ihre Altmöbel können jedoch auch für andere noch nützlich sein - wenden Sie sich an karitative Vereine in Ihrer Umgebung-Wohnregion.
- IT** Al momento dell'eliminazione del vostro mobile usato, i componenti in legno, in plastica ed in metallo possono essere separati ed essere portati in discarica verso i contenitori idonei per favorire la loro valorizzazione. Tuttavia, non dimenticate che potreste prolungare la durata di vita dei vostri prodotti usati contattando le associazioni caritative della vostra regione.
- RU** Для того, чтобы избавиться от старой мебели, можно рассортировать детали из дерева, пластика и металла и отправить в пункты сбора утиля для их переработки и вторичного использования. Однако, не забывайте, что вы можете продлить срок службы изделий, связавшись с благотворительными организациями вашего региона.
- PT** Aquando da eliminação do seu móvel usado, os componentes em madeira, plástico e metal, podem ser separados e depositados nos respetivos contentores para reciclagem e valorização. De qualquer modo, não esqueça que pode prolongar a vida útil dos seus produtos usados contactando as associações caritativas da sua zona.

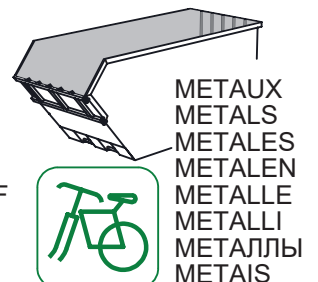
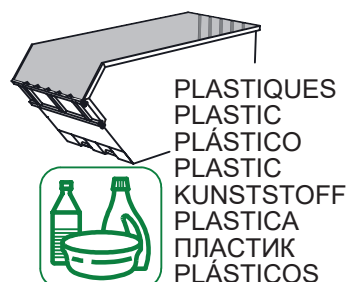
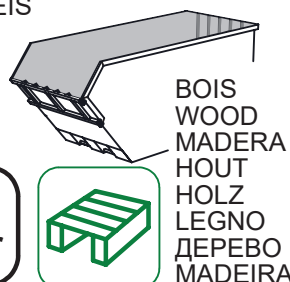
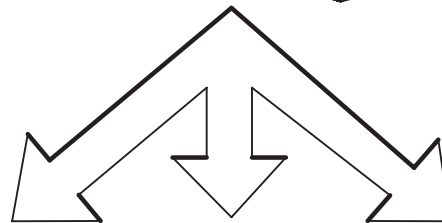
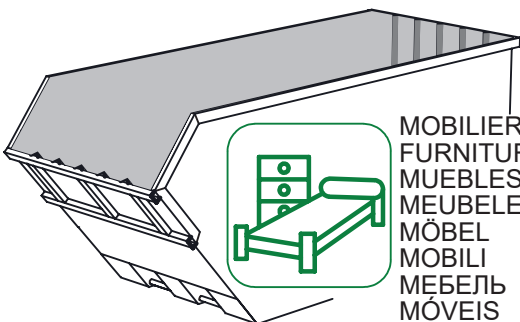
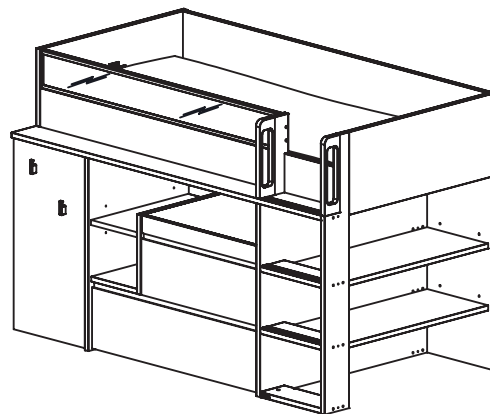
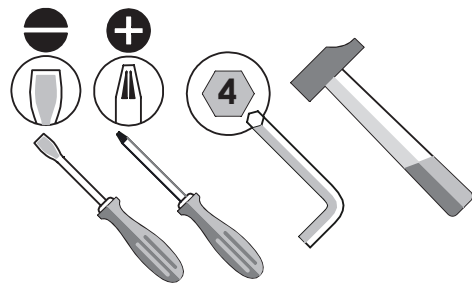

Pour en savoir plus :
www.consignesdetri.fr