

Aufbauanweisung (bitte aufbewahren)

NL Opbouwinstructies (A.u.b. bewaren)

F Consignes d'assemblage (à conserver)

GB Directions for assembly (please save it)

HR Uputa sastavljanja (obavzno sačuvajte)

SLO Navodila za sestavljanje (Skrbno shranite)

H Összeszerelési útmutató (kérjük megőrizni)

SK Návod na montáž (prosím uschovať)

CZ Návod k montáži (uložte si ho prosím)

BG Инструкция за сглобяване (Моля запазете настоящата инструкция)

RO Instrucțiuni de montaj (vă rugăm, păstrați documentul)

EXPRESS
MÖBEL

Express Möbel GmbH & Co. KG
Konrad-Nolte-Str. 16
D-76726 Germersheim
Tel.: 0049-7274-5116-0
Fax: 0049-7274-5116-100
support@express-moebel.de

Beimöbel - GD39ZK

NL Bijmeubels

F Meubles d'appoint

GB Chest system

HR Dodatni namještaj

SLO Pohišstvo na nogah

H További bútorok

SK Doplnkový nábytok

CZ Drobný nábytek

BG Малогабаритни мебели

RO Accesorii pentru mobilier

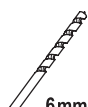
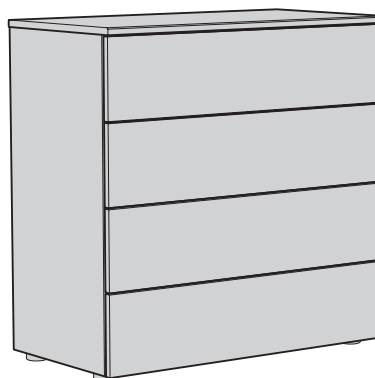
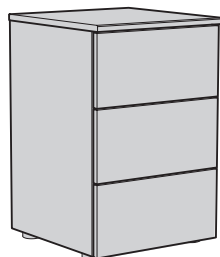
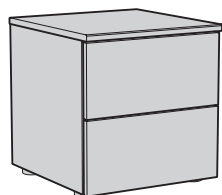
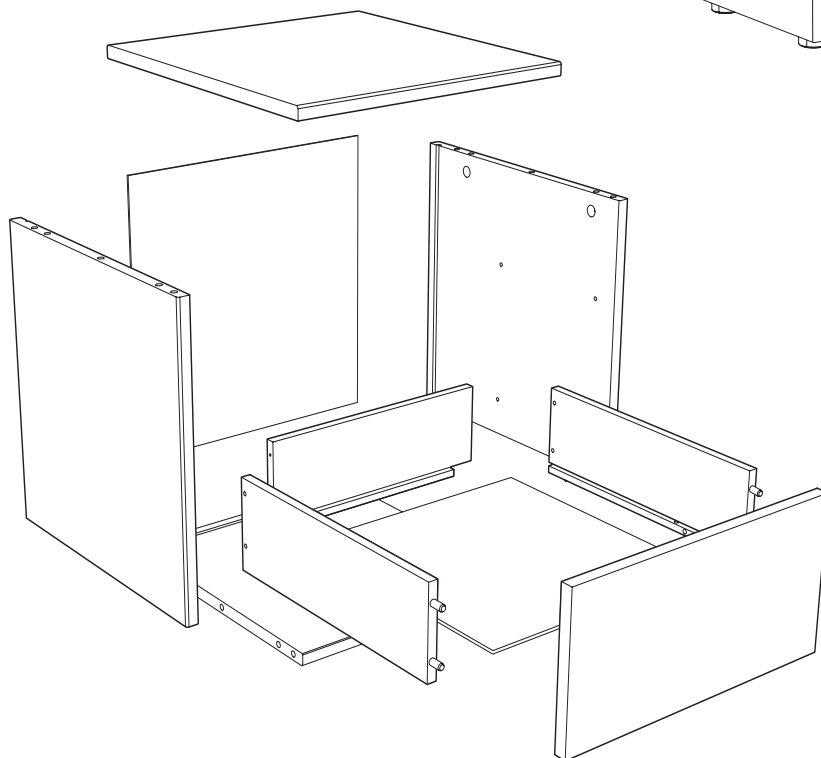
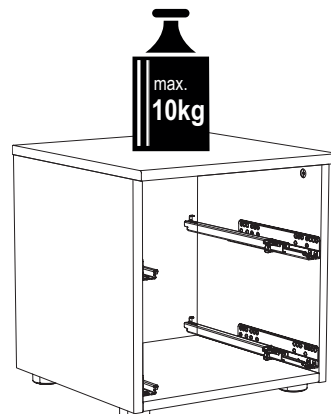

Lesen Sie zuerst die Aufbauanweisung und beginnen Sie dann mit der Montage.

- NL Voordat uw met de montage begint, a.u.b. de opbouw instructies lezen
 F Avant de commencer avec le montage, nous vous prions de bien lire les consignes d'assemblage.
 GB Before starting with the fitting, please read carefully the directions for assembly.
 HR Prije montiranja pročitajte uputu za sastavljanje.
 SLO Najprej preberite navodila za sestavljanje in šele nato pričnite z montažo.
 H Olvassa el először az összeszerelési útmutatót, és csak ezután kezdje el a szerelést.
 SK Najskôr si prečítajte návod na montáž a až potom začnite s montážou.
 CZ Návod k montáži si nejdříve přečtěte a pak začnete s montáží.
 BG Първо прочетете инструкцията за сглобяване и след това започнете с монтажа.
 RO Mai întâi citiți instrucțiunile de montaj, și numai după aceea începeți montajul.

Bei nicht vorschriftsmäßiger und/oder nicht fachmännischer Montage wird für Personen- oder Sachschäden keinerlei Haftung übernommen.

- NL In geval van persoonlijke ongelukken en materiële schade is aansprakelijkheid uitgesloten, indien de montage niet overeenkomstig de voorschriften en/of niet door een vakman werd uitgevoerd.
 F Nous déclinons toute responsabilité en cas de dommages corporels ou matériels dus à un montage non conforme aux instructions et/ou exécuté incorrectement.
 GB We will not accept any liability in case of personal injury or material damages, if not assembled according to the regulations and/or by specialists.
 HR U slučaju nepropisane i/ili ne stručne montaže ne preuzimamo odgovornost za nastanak štete osobama ili stvarima.
 SLO Pri montaži brez upoštevanja navodil in/ali pri nestrokovni montaži se ne prevzame nikakršne odgovornosti za telesne poškodbe ali materialno škodo.
 H A nem előírás szerint és/vagy nem szakemberrel végzett összeszerelés esetén felmerülő személyi és anyagi károkról semmilyen felelősséget nem vállalunk.
 SK V prípade montáže v rozpore s predpismi a/alebo neodbornej montáže nepreberáme v prípade ujmy na zdraví alebo vecných škôd žiadnu záruku.
 CZ Při montáži v rozporu s předpisy nebo při neodborné montáži nepřebírá výrobce žádnou záruku za škody vzniklé na osobách nebo předmětech.
 BG Ако монтажът не е извършен съгласно инструкцията и/или от специалисти, фирмата не поема отговорност в случай на нараняване на хора или при материални щети.
 RO În caz de montaj efectuat necorespunzător și/sau neprofesionist nu ne asumăm niciun fel de responsabilitate pentru vătămarea persoanelor sau pentru pagubele materiale.

1



**FIRST
STEP!**

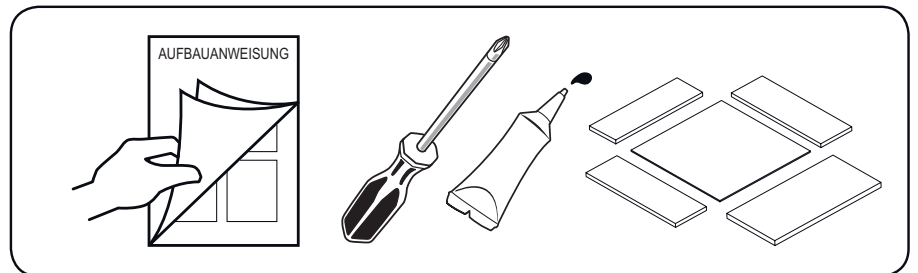
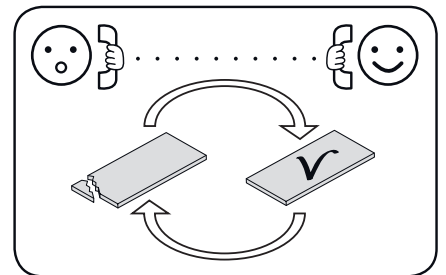
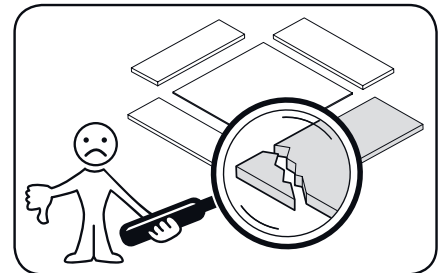
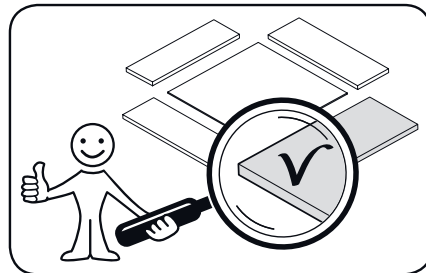

Beschlagsübersicht: letzte Seite

- | | | | |
|---|--|--|---|
| NL Beslagoverzicht: laatste pagina | GB Fitting survey: last page | H Kötőelem áttekintés: utolsó oldal | CZ Přehled kování: poslední stránka |
| F Tableau de quincaillerie: dernière page | HR Pregled dijelova: posljednja stranica | SK Prehľad kování: posledná strana | BG Монтажни елементи: последна страница |
| | | SLO Seznam sestavnih delov: zadnja stran | RO Vedere de ansamblu: ultima pagină |



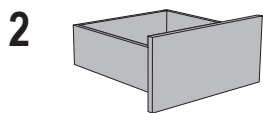

502190

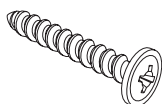

SX4,0*35RW

3

564120



LEIMTUBE-D2_12ML

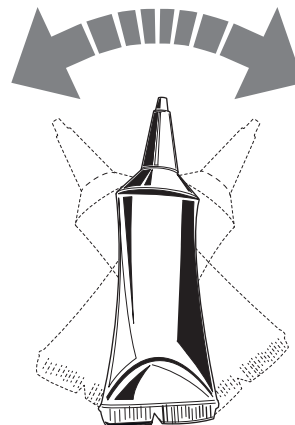
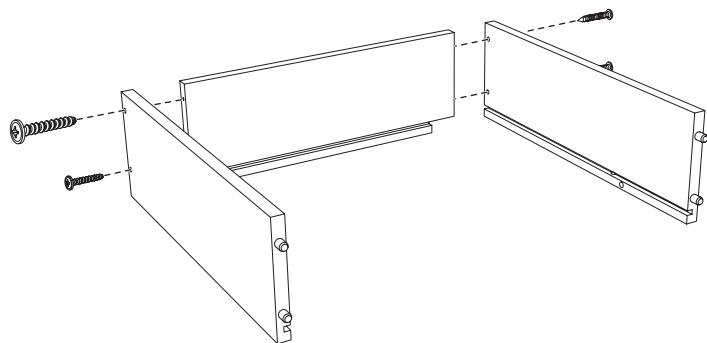

4

564120



LEIMTUBE-D2_12ML

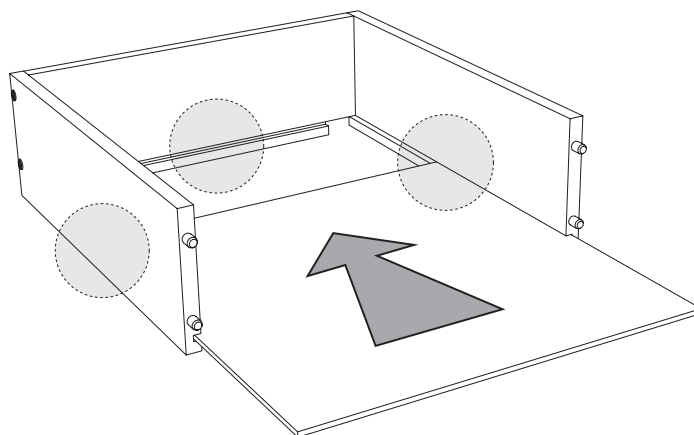
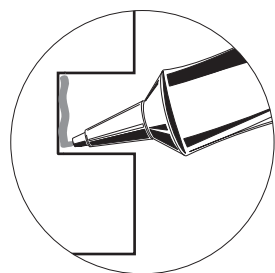

5

564120



LEIMTUBE-D2_12ML

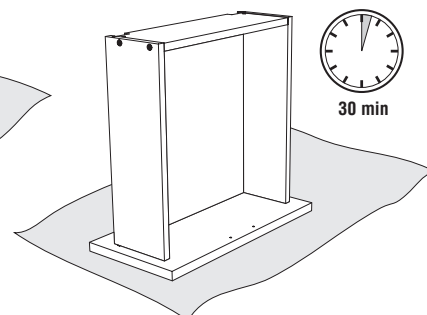
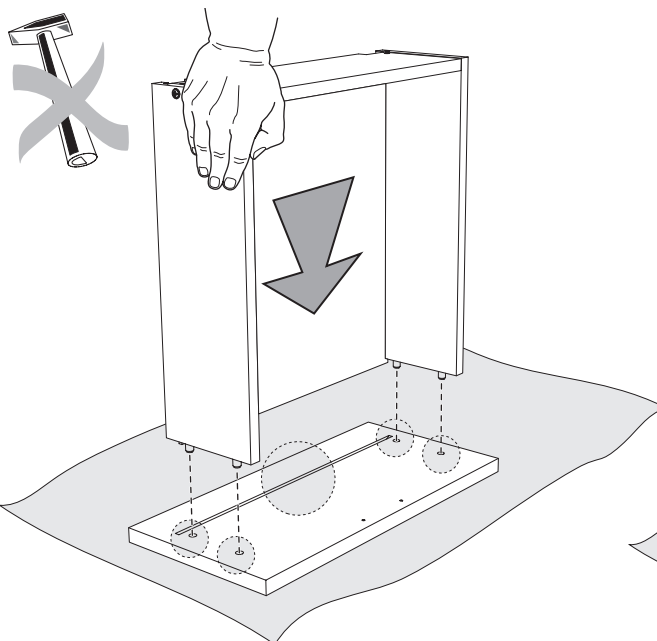

6

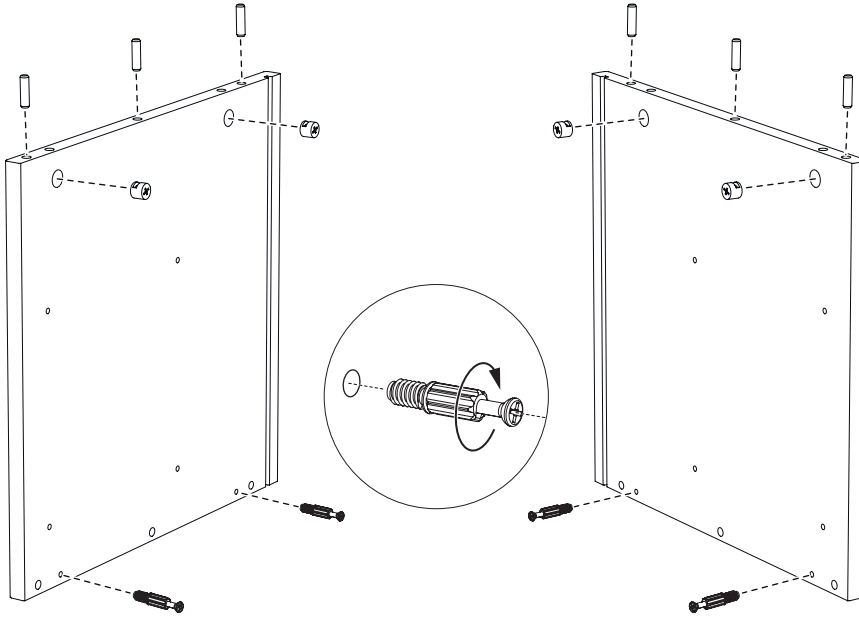
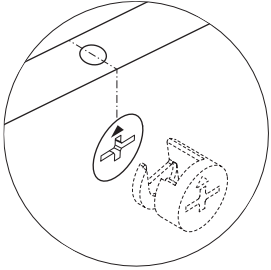
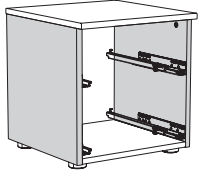

023060

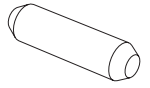

HDUEBEL-08*30

562470

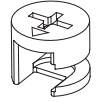

EXC-15MM-OHNE

575807

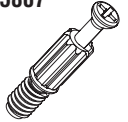

BO-24/7-EU/HÄFELE

7

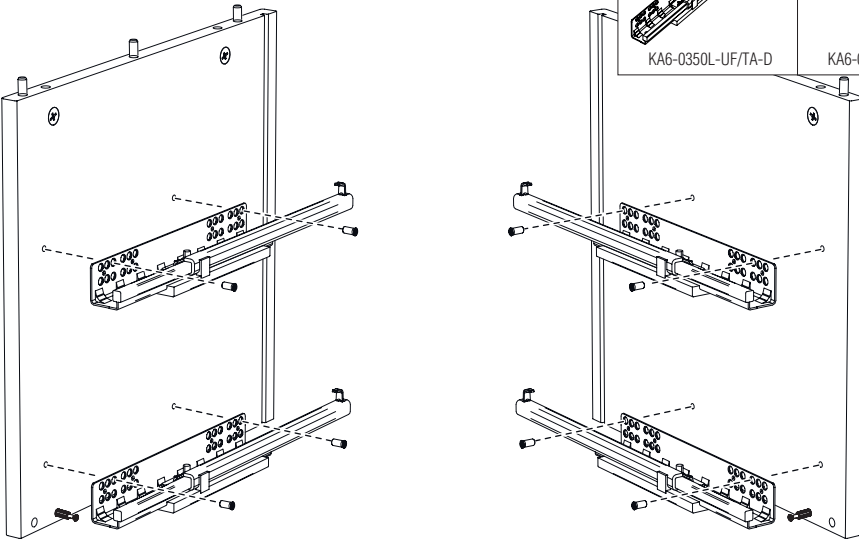
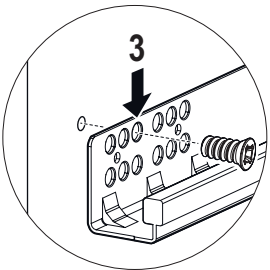

573148

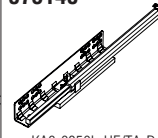

KA6-0350L-UF/TA-D

573149

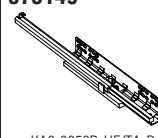

KA6-0350R-UF/TA-D

165200

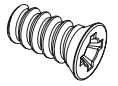

EU6,3*13FLAKO

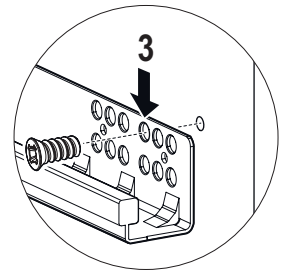

8

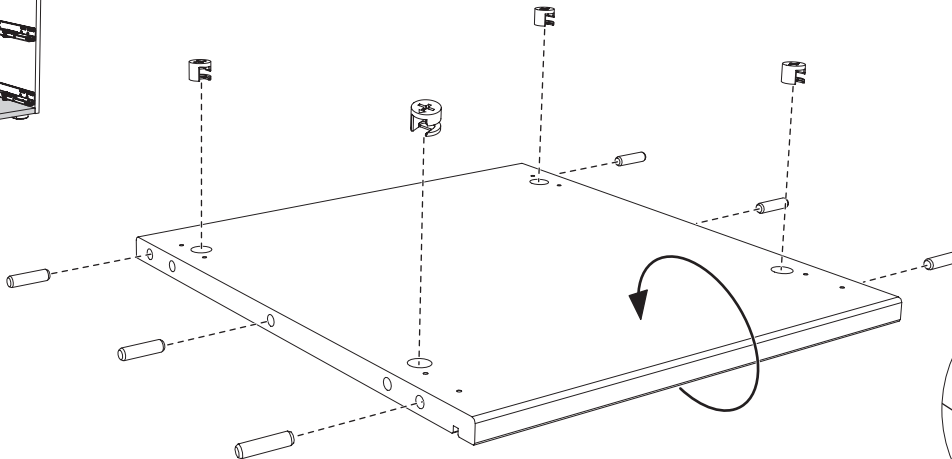
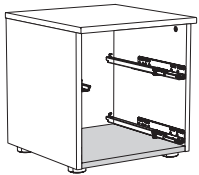

023060

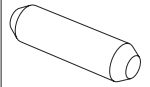

HDUEBEL-08*30

562470

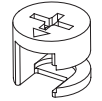

EXC-15MM-OHNE

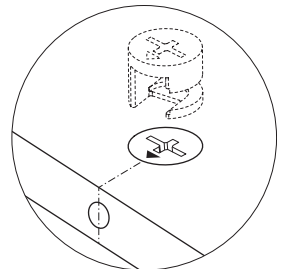

9

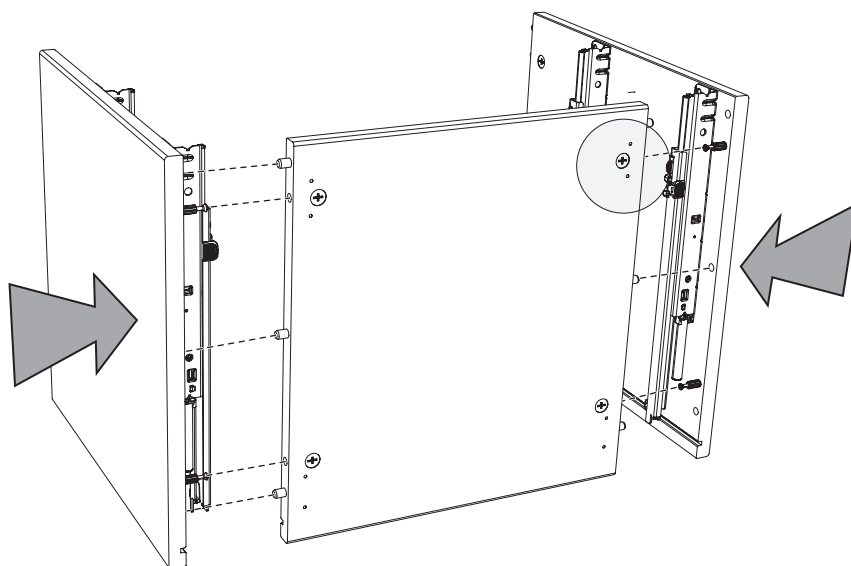
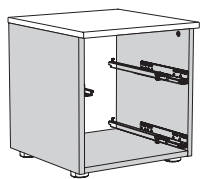

10

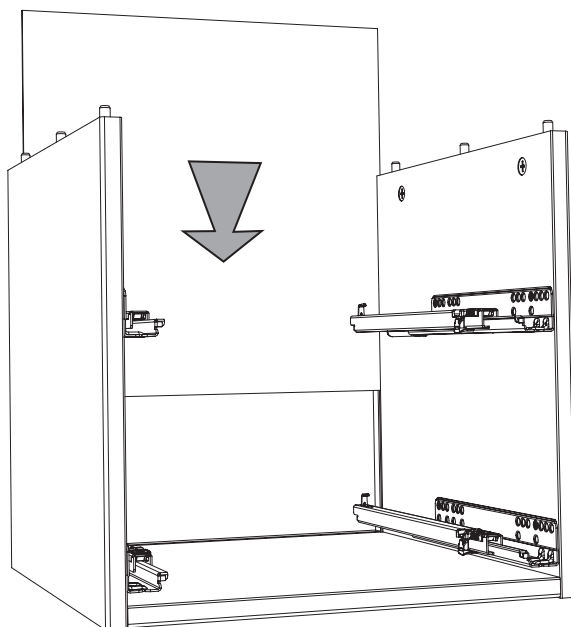
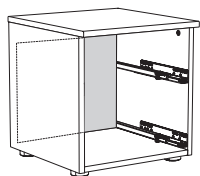

11

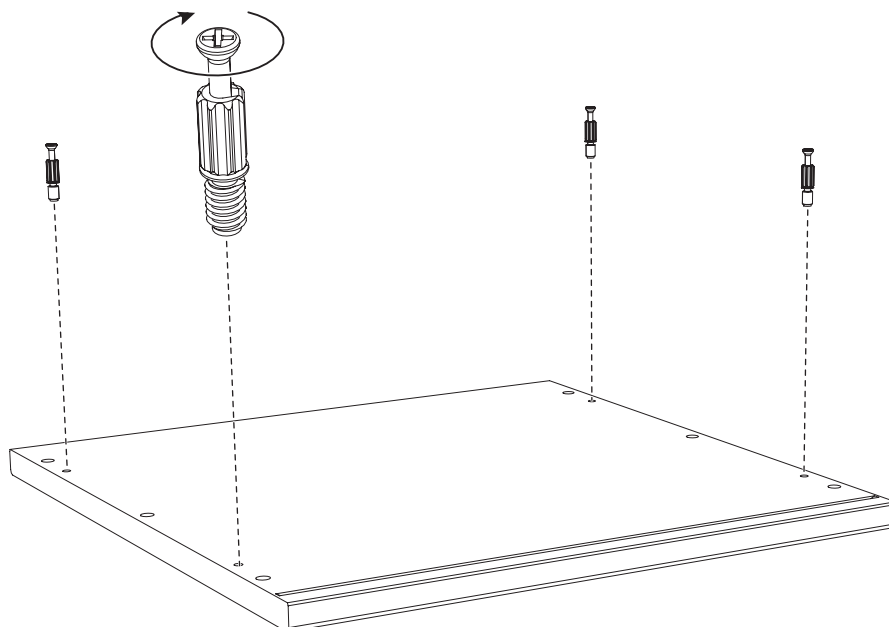
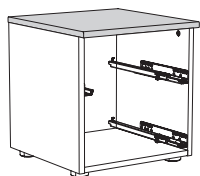

575807

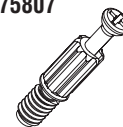

BO-24/7-EU/HÄFELE

12

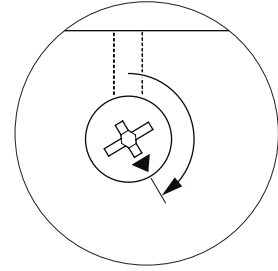
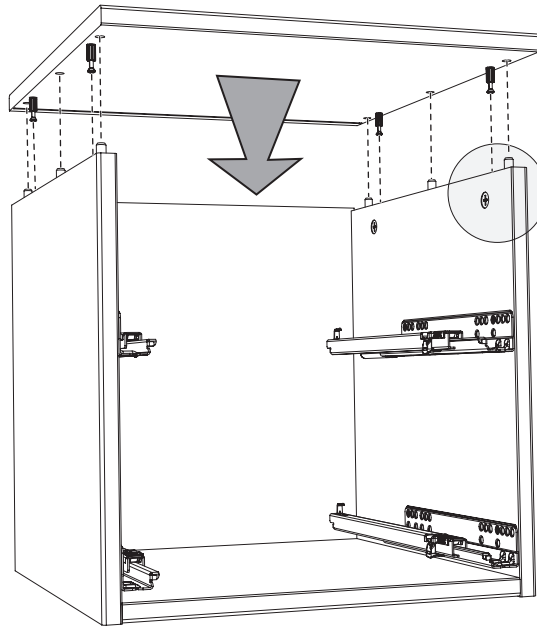
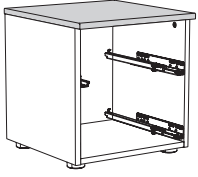

13

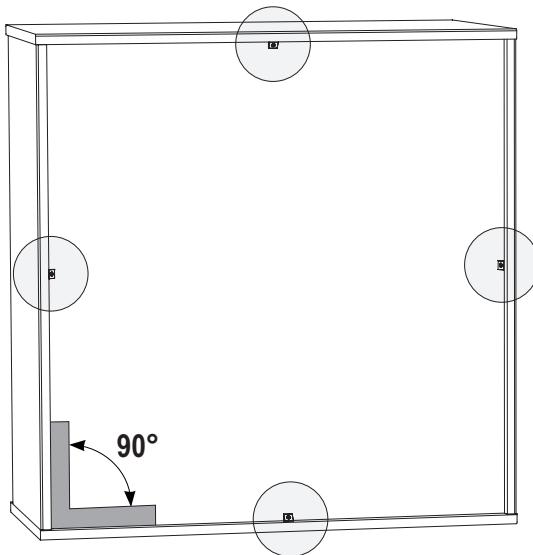
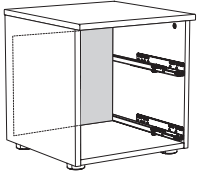

100035

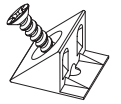

RW-WINKEL-100

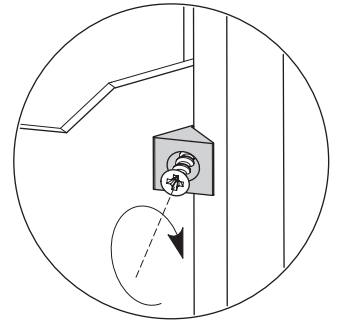
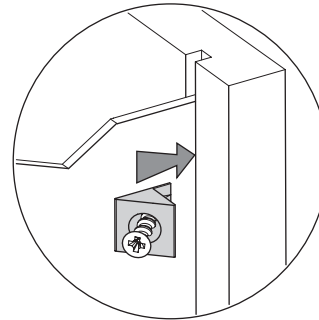

14

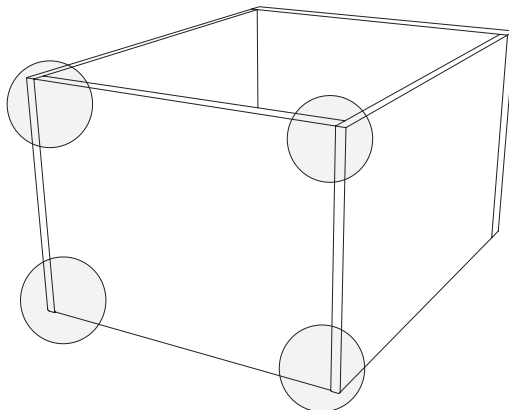
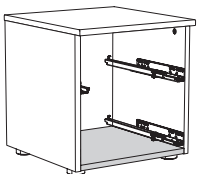

568791

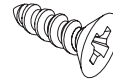

SX4,0*15FLAKO

568897

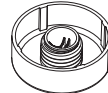





MOEBELFUSS-50/18-26MM

568908

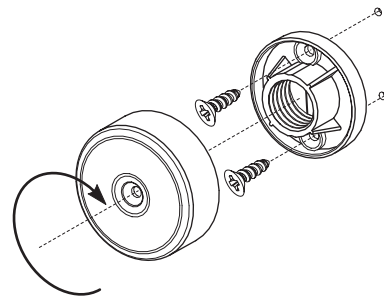

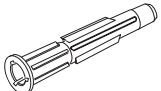
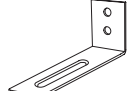
MOEBELFUSS-50-BASIS

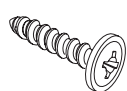

<p>028890</p>  <p>KU-DUEBEL-8MM/ALLZWECK</p>	<p>024910</p>  <p>WI-1.80.034</p>	<p>025850</p>  <p>U-SCH-12MM/DIN125-EX</p>	<p>569069</p>  <p>SX3,5*17RW</p>	<p>566407</p>  <p>SX4,5*60FLAKO/S-CAP</p>
--	---	--	--	---



ACHTUNG!

Aus Sicherheitsgründen muss dass Möbelteil an der Wand befestigt werden. Beiliegendes Befestigungsmaterial eignet sich nur für Massivwände. Für andere Wände müssen Spezialdübel verwendet werden.

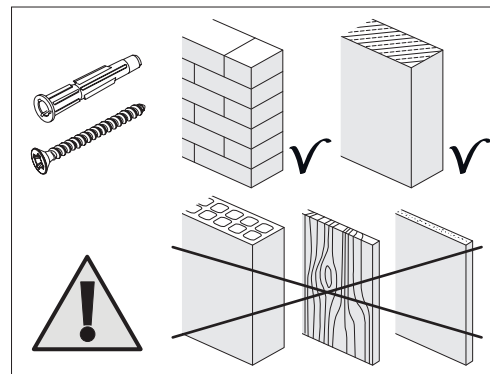
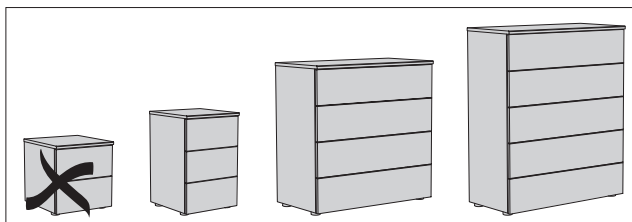

- NL **LET OP!** Uit veiligheidsoverwegingen moet het meubeldeel aan de wand bevestigd worden. Bijgevoegt bevestigings materiaal is alleen bruikbaar voor massieve wanden. Voor andere wanden moeten speciale schroeven gebruikt worden.
- F **ATTENTION!** Pour des raisons de sécurité le meuble doit être fixé au mur. Le matériel ci-joint est approprié pour des murs épais. Pour d'autres murs utiliser des chevilles spéciales.
- GB **ATTENTION!** For safety reasons please fix the unit to the walls. Enclosed fittings for stoned wall only. For other walls please use other pegs.
- HR **OPREZ!** Zbog sigurnosnih razloga namještaj morate pričvrstiti na zid. Materijal za pričvršćivanje koji je u prilogu pričvrstiti možete samo na masivne zidove. Za ostale vrste zidova morate koristiti posebne tiplove.
- SLO **POZOR!** Iz varnostnih razlogov je potrebno del pohišstva pritrčiti na steno. Priložen material za pritrčitev je primeren samo za masivne stene. Za druge stene je potrebno uporabiti posebne vložke.
- H **FIGYLEM!** Biztonsági okokból a bútordarabot a falhoz kell erősíteni. A mellékelt rögzítőanyag csak masszív falaknál alkalmazható. Egyéb falaknál speciális tiplít kell használni.
- SK **POZOR!** Z bezpečnostných dôvodov musí byť táto časť nábytku pripevnená na stenu. Priložený materiál na upevnenie sa hodi len pre masívne steny. Pre ostatné druhy stien použite špeciálne hmoždinky.
- CZ **POZOR!** Z bezpečnostních důvodů musí být nábytek upevněn ke stěně. Příložený materiál k upevnění ke stěně je vhodný pouze k použití na masivních zdech. Na jiné stěny musí být použity speciální hmoždinky.
- BG **ВНИМАНИЕ!** От съображения за сигурност мебелите трябва да бъдат закрепени към стената. Приложените закрепващи приспособления са подходящи само за масивни стени. За други видове стени трябва да се използват специални дюбели.
- RO **PERICOL** Din motive de siguranță, piesa de mobilier trebuie fixată pe perete. Materialul de fixare inclus în pachetul de livrare este adecvat numai pentru pereți masivi. Pentru alte tipuri de pereți trebuie utilizate dibluri speciale.

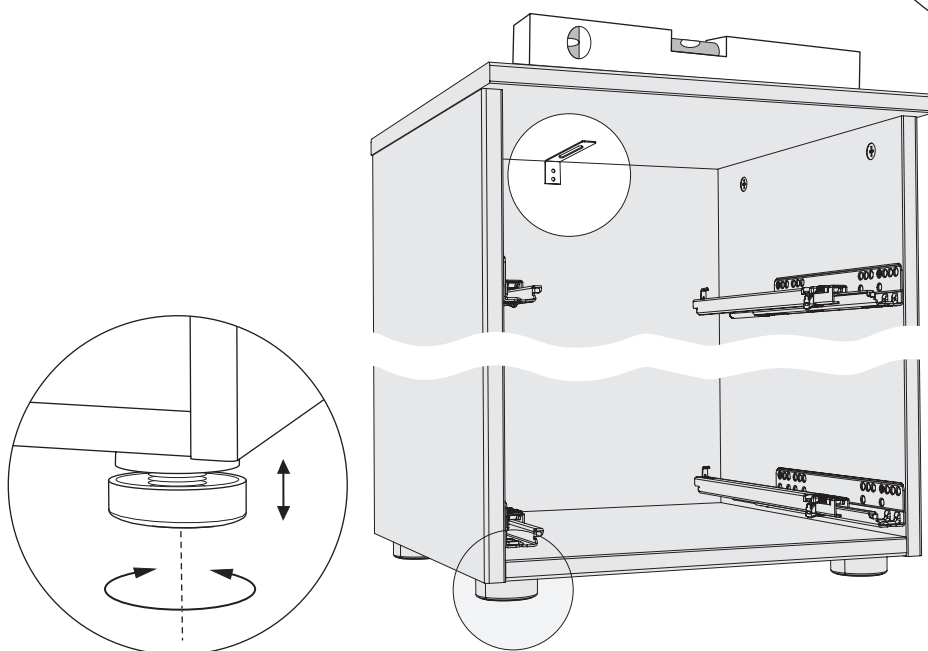
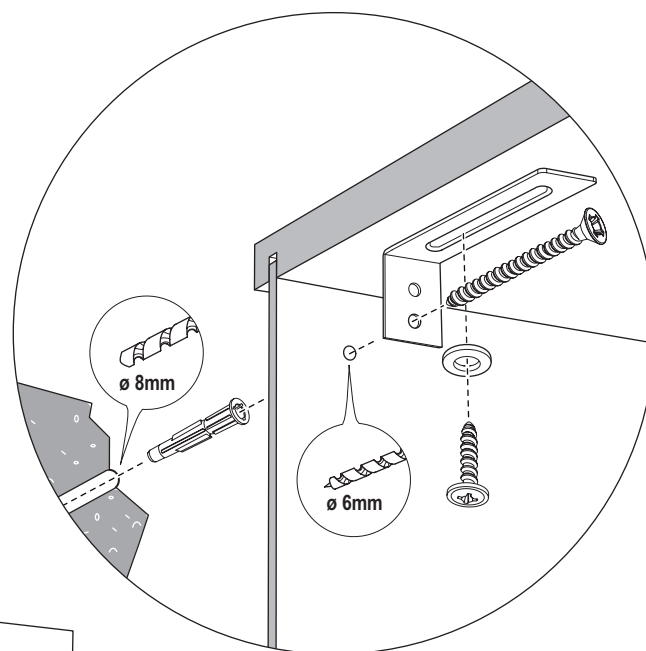

501990

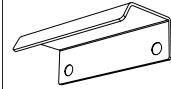

GRIFF NR. 30107

568791

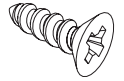

SX4,0*15FLAKO

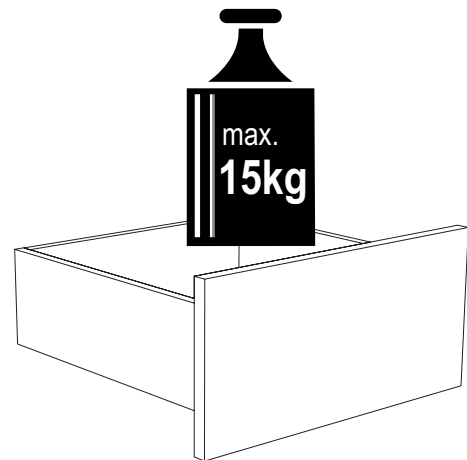
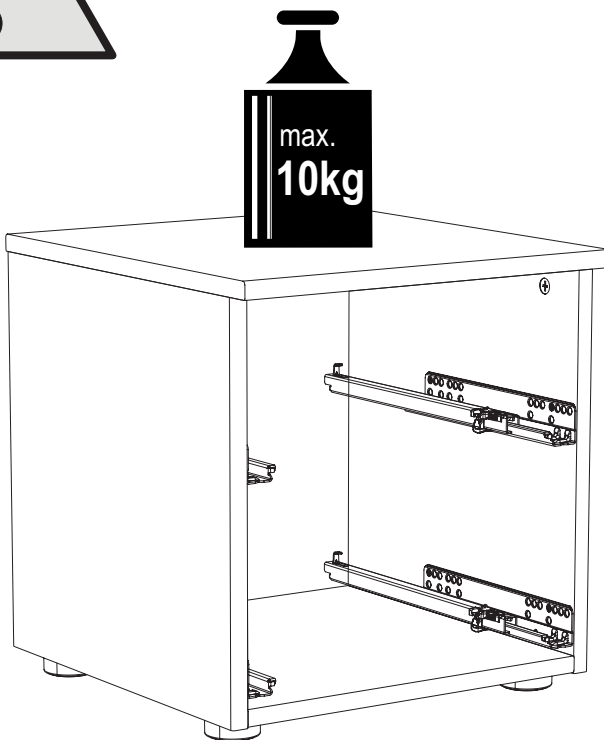
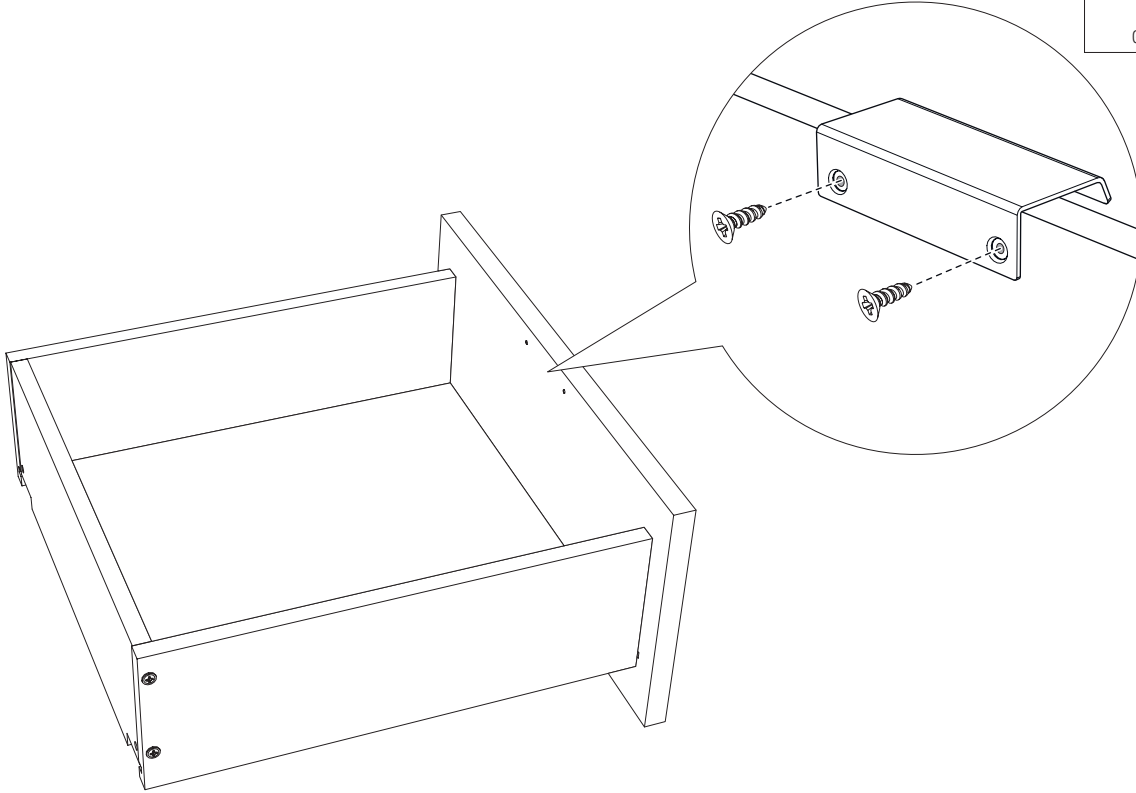

17

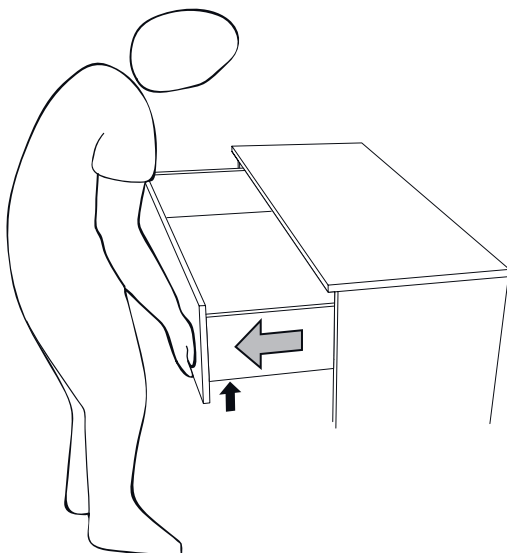
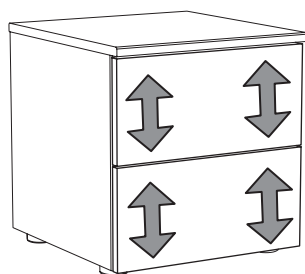
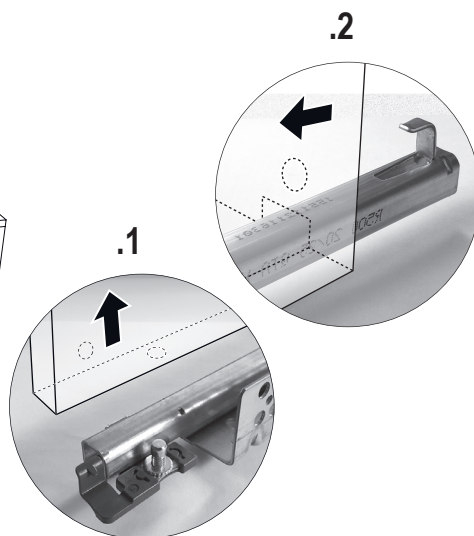
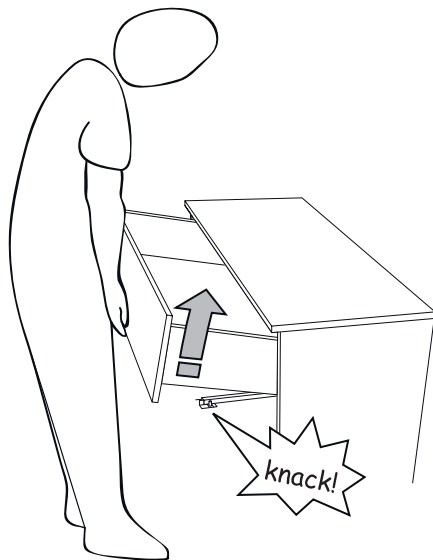
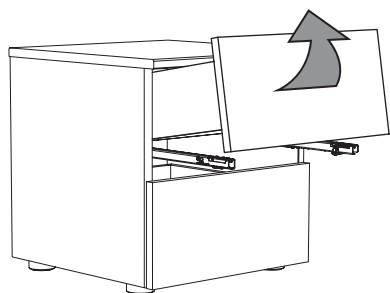
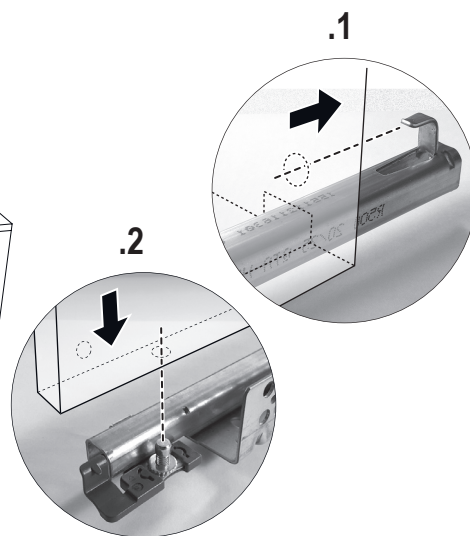
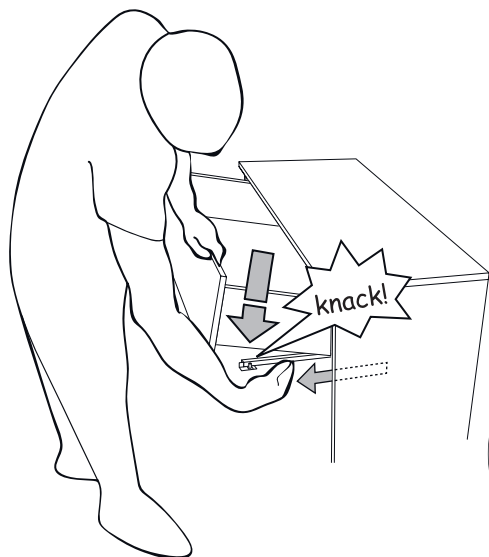
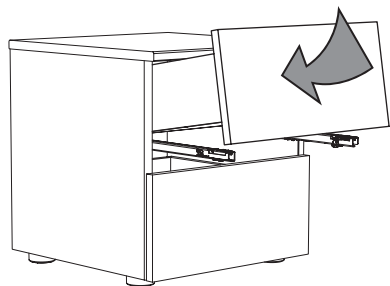

Servicekarte

NL Servicekaart GB Service card SLO Servisna kartica SK Servisná karta BG Сервизна карта
 F Carte de service HR Servisna karta H Szervíz kártya CZ Servisní karta RO Carte de service



Express Möbel GmbH & Co. KG, Konrad-Nolte-Str. 16, D-76726 Germersheim, Tel.: 0049-7274-5116-0, Fax: 0049-7274-5116-100, support@express-moebel.de

Sorgfalt bei der Produktion und der Endkontrolle garantieren mängelfreie Beschaffenheit unserer Produkte. Sollten Sie dennoch Grund zu einer Mängelrüge haben, so senden Sie bitte diese Servicekarte und bei Bedarf die markierte Aufbauanweisung an Ihren Händler.

- NL Zorgvuldigheid bij de productie en de eindcontrole garanderen dat onze producten vrij zijn van gebreken. Indien u toch klachten heeft, stuur dan alsublieft bijgaande servicekaart en zo nodig de montagehandleiding met toelichting naar uw verkoper.
- F Nous veillons soigneusement à la qualité impeccable de nos produits pendant la production et avec le contrôle avant le chargement. Si toutefois, vous êtes amenés à nous adresser une réclamation, nous vous prions de nous joindre la carte de service et la notice de montage sur lesquelles vous aurez marqué la pièce en question.
- GB Our production techniques and final quality inspections ensure that our products are faultlessly manufactured. However, if you should have any reason for complaint, please send the service card to your dealer, if necessary enclosing the assembly instructions to indicate the faulty part.
- HR Pozornost prilikom proizvodnje i finalne kontrole jamče besprijekorno stanje naših proizvoda. Imate li ipak osnova za reklamaciju, molimo da tada pošaljete priloženu servisnu kartu i prema potrebi označeno uputstvo za sklapanje vašem trgovcu.
- SLO Skbnost pri izdelavi in zaključni kontroli zagotavlja izdelavo naših produktov brez napak. V primeru, da imate razlog za pritožbo, Vas prosimo da svojemu trgovcu pošljete pritrjeno servisno kartico in po potrebi tudi označeno navodilo glede sestavljanja.
- H A gondosság a gyártás és a végső ellenőrzés során garantálja termékeink hibátlan minőségét. Ha Önnek ennek elnére is oka lenne az áru kellékhányának bejelentésére, úgy kérem küldje el a mellékelt szervíz kártyát és szükség esetén a megjelölt összeszerelési útmutatót kereskedőjének.
- SK Dôslednosť pri výrobe a výstupnej kontrole je zárukou bezchybných vlastností našich výrobkov. Ak však aj napriek tomu máte dôvod na reklamáciu, zašlite priloženú servisnú kartu a v prípade potreby označený návod na montáž svojmu predajcovi.
- CZ Pečlivost během výroby a výstupní kontrola zaručují technicky bezvadné vlastnosti našich produktů. Pokud byste přesto měli důvod k reklamaci, zašlete svému obchodníkovi přiloženou servisní kartu a v případě potřeby také označený návod k montáži.
- BG Прецизността при производството и при крайния контрол гарантират отличното качество на нашите продукти. Ако въпреки това имате основание за reklamacия, моля изпратете на Вашия продавач приложената сервизна карта, а при нужда - маркираната инструкция за сглобяване.
- RO Atenția în timpul producției și la verificarea finală garantează calitatea impecabilă a produselor noastre. Dacă totuși aveți motive de reclamație din cauza unor deficiențe de calitate, trimiteți distribuitorului dumneavoastră cartea de service atașată și - dacă este nevoie - instrucțiunea de montaj marcată.

Beimöbel - GD39ZK

Typ NL Type GB Type SLO Tip SK Typ
 BG Вид F Type HR Tip H Tipus CZ Typ RO Tip

Datum NL Date GB Date SLO Datum SK Dátum
 BG Дата F Date HR Datum H Dátum CZ Datum RO Data

Kaufvertragsnummer / Lieferscheinnummer

- NL Koopcontract nr. / vervoerdocument nr.
 F No. contrat d'achat / no. bon de livraison
 GB Purchase contract no. / delivery note no.
 HR Broj prodajnog ugovora / Broj otpравnice
 SLO Številka kupoprodajne pogodbe / Številka dostavnice
 H Numărul contractului de achiziționare / numărul bonului de livrare
 SK Vételi szerződés száma / Szállítólevél száma
 CZ Číslo kúpnej zmluvy / číslo dodacieho listu
 BG № на договора за продажба / № на деливъри ордера
 RO C.kupni smlouvy / číslo dodacého listu
- Fehlerursache**
- NL Oorzaak van het gebrek H Hiba oka
 F Raison de la réclamation SK Příklad chyby
 GB Reason for complaint CZ Příčina závady
 HR Uzrok greške BG Причина за дефекта
 SLO Vzrok napake RO Cauza defecțiunilor



Beschlagsübersicht

NL Beslagoverzicht GB Fitting survey SLO Seznam sestavnih delov SK Prehľad kování BG Монтажни елементи
 F Tableau de quincaillerie HR Pregled dijelova H Kötőelem áttekintés CZ Přehled kování RO Vedere de ansamblu

023060 HDUEBEL-08*30	024910 WI-1.80.034	025850 U-SCH-12MM/DIN125-EX	028890 KU-DUEBEL-8MM/ALLZWECK	100035 RW-WINKEL-100	165200 EU6,3*13FLAKO	501990 GRIFF NR. 30107	502190 SX4,0*35RW
562470 EXC-15MM-OHNE	564120 LEIMTUBE-D2_12ML	566407 SX4,5*60FLAKO/S-CAP	568791 SX4,0*15FLAKO	568897 MOEBELFUSS-50/18-26MM	568908 MOEBELFUSS-50-BASIS	569069 SX3,5*17RW	573148 KA6-0350L-UF/TA-D
573149 KA6-0350R-UF/TA-D	575807 BO-24/7-EU/HÄFELE						