

## Aufbauanleitung / Assembly instruction + Garantiekarte / guarantee card

Modell: 58307WS9/58311ES9 JUBA W120/JUBA E120 #10190

04/22

Bitte heben Sie die Garantiekarte und den Kaufbeleg auf!

Reklamationen und Ersatzteilbestellungen können nur unter Vorlage der Garantiekarte bearbeitet werden.

Die Garantiezeit beträgt 6 Monaten mit anschließender gesetzlicher Gewährleistung bis 2 Jahre ab Kaufdatum.

-----

Please keep the guarantee card and the receipt of purchase!

Claims and spare part orders can only be processed with this guarantee card.

Guarantee is valid for 6 months and the warranty 2 years since purchasing date.

-----

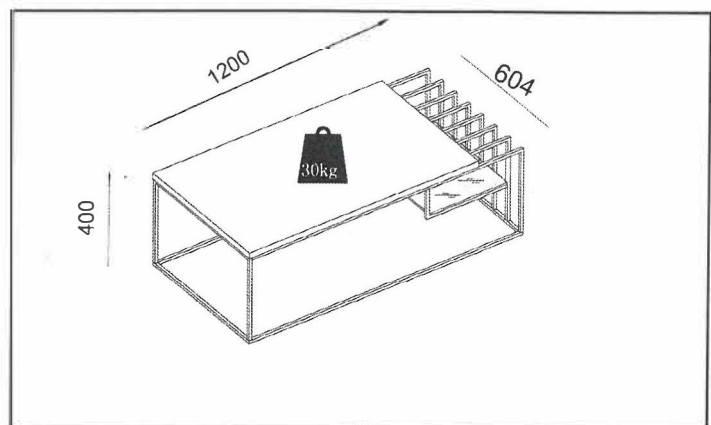
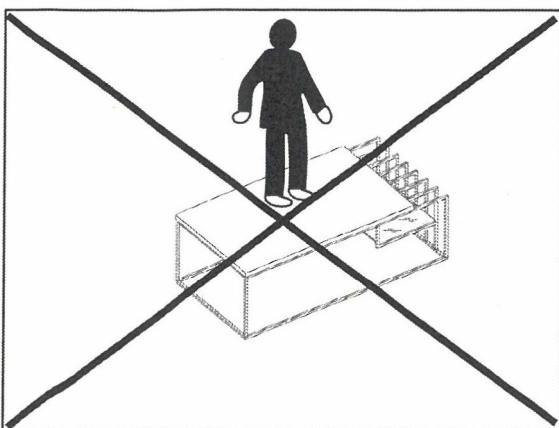
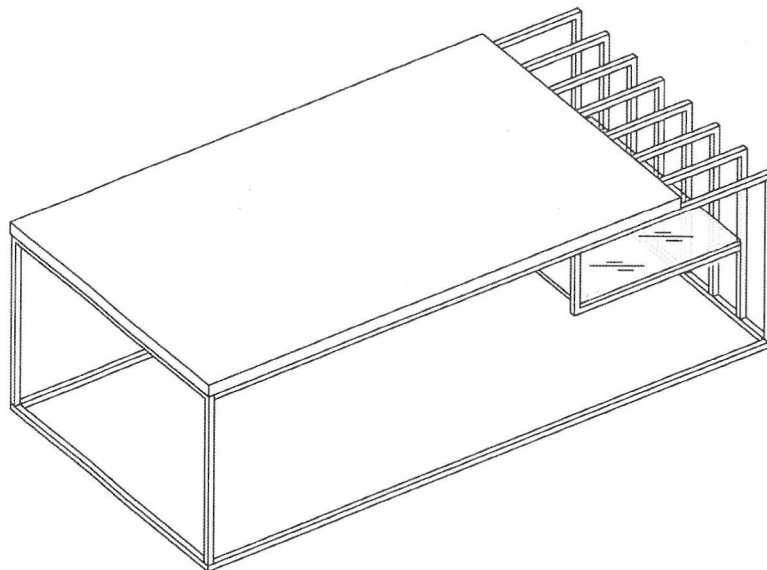

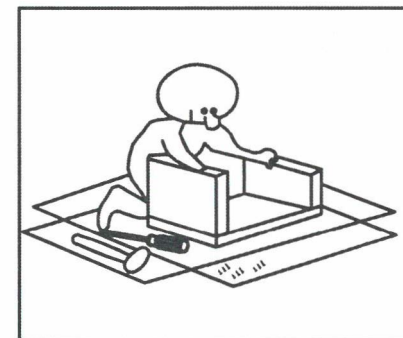
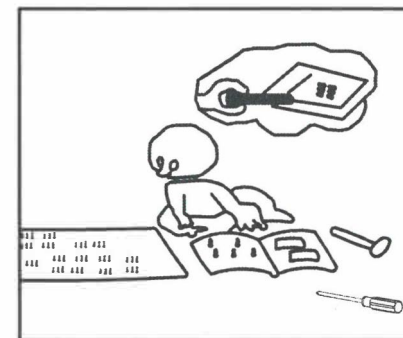
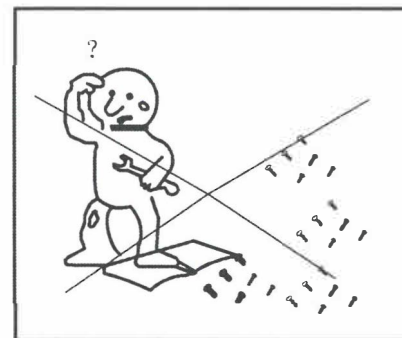
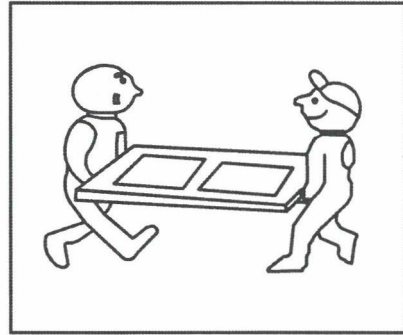
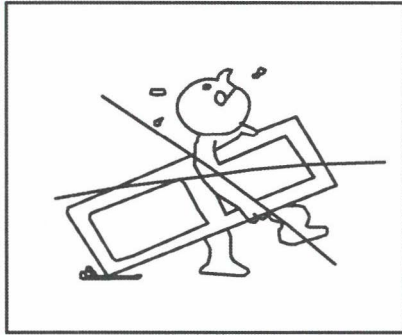
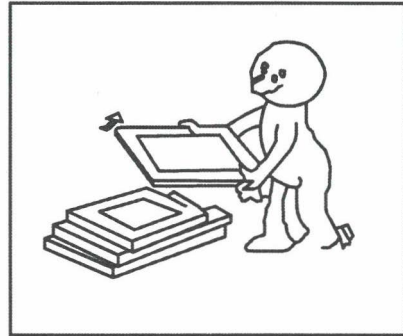
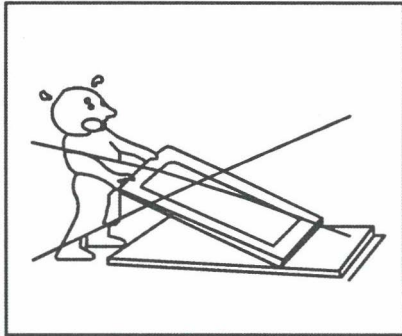
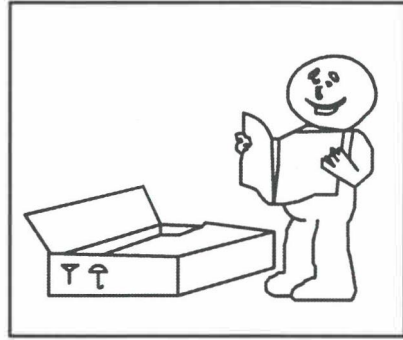
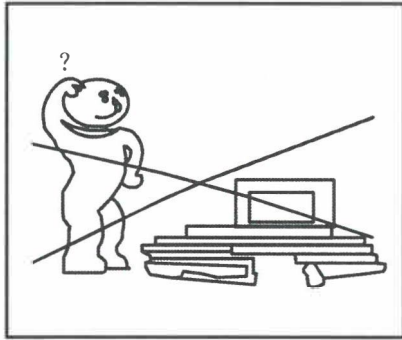

## Garantiekarte / guarantee card

**Model:** 58307WS9/58311ES9    **JUBA W120/JUBA E120**    #10190    04/22

Bitte bei Ersatzteilbestellungen die fehlenden oder beschädigten Teile kennzeichnen.

Please mark the missing or damaged parts if you place a spare part order.

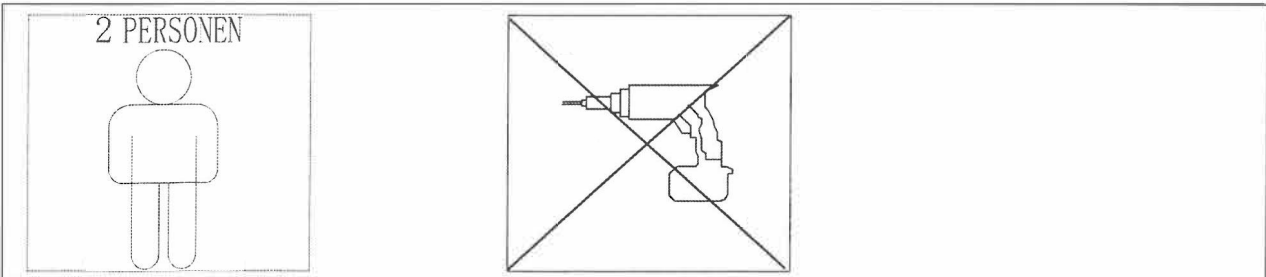
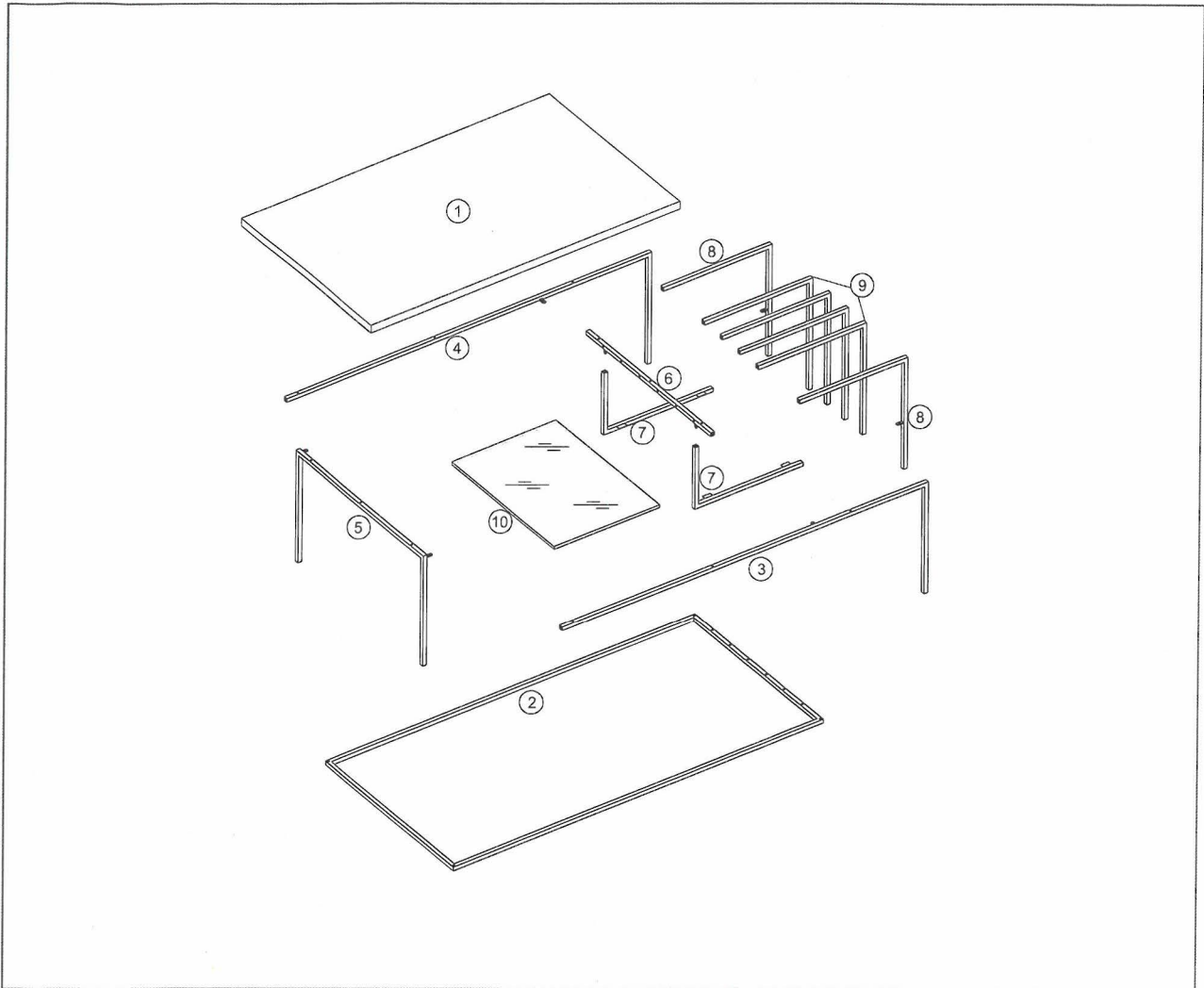

A	x16	B	x8	C	x12	D	x1	E	x6	F	x4
M5*20mm		M5*8mm		M4*25mm		M4		φ 10*3mm		φ 5*1.8mm	

# STEP 1

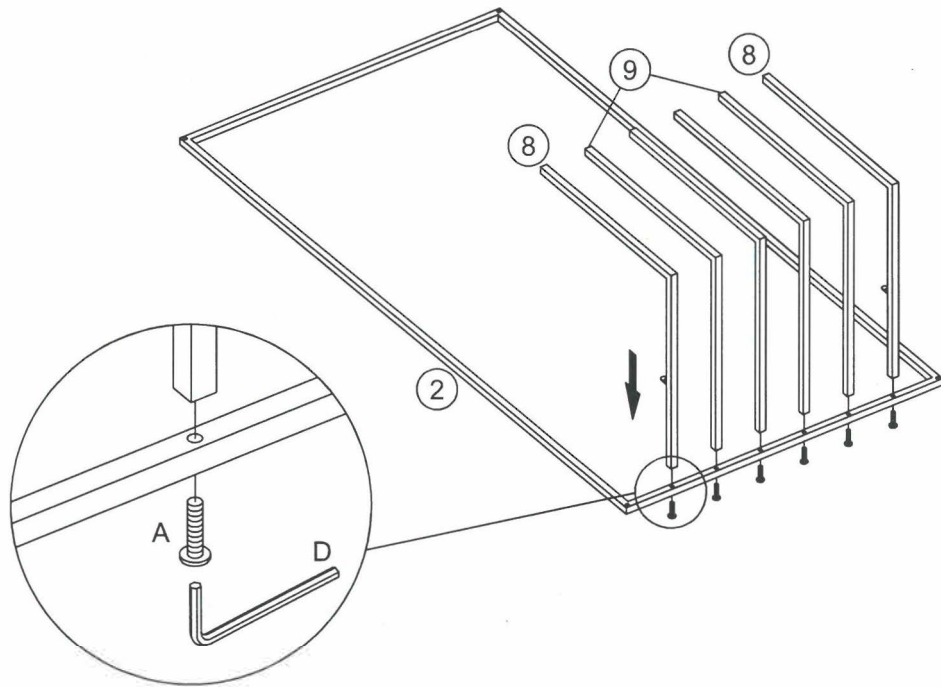



A	x6
	
M5*20mm	

D	x1
	
M4	

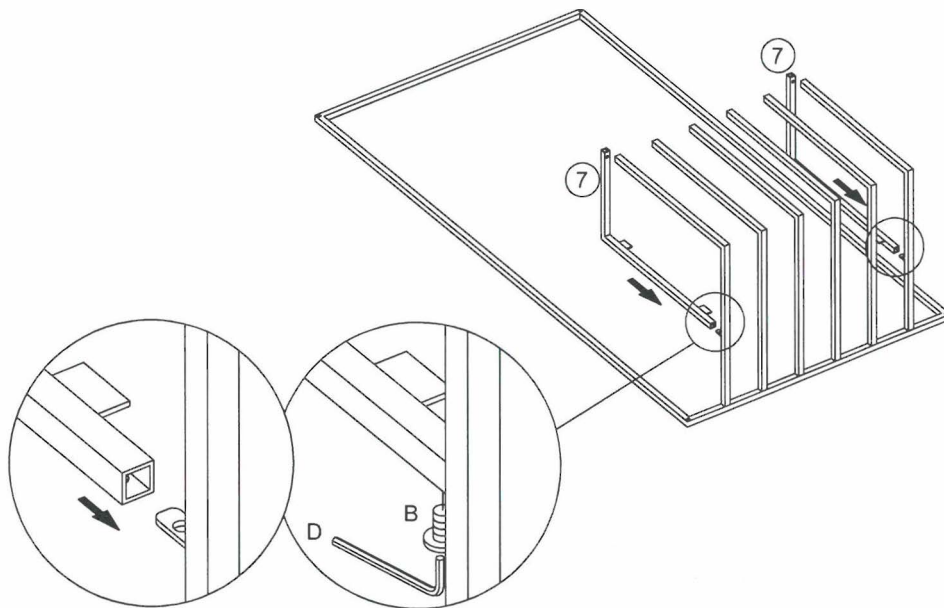
# STEP 2





B	x2
	
M5*8mm	

D	x1
	
M4	

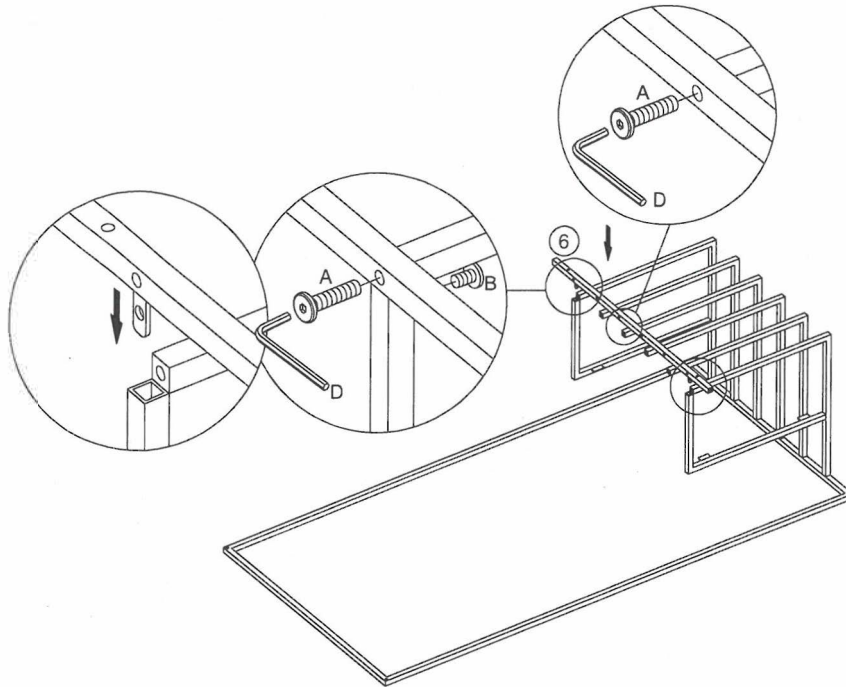

# STEP3



A	x6	B	x2	D	x1
					
M5*20mm		M5*8mm		M4	

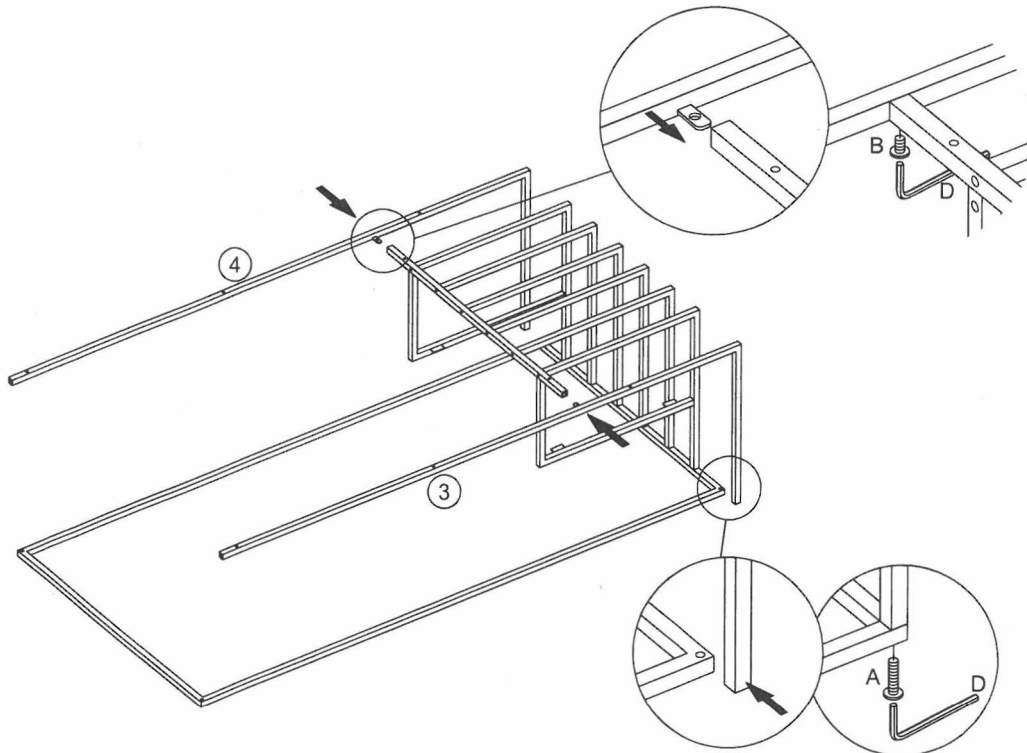

# STEP4



A	x2	B	x2	D	x1
					
M5*20mm		M5*8mm		M4	

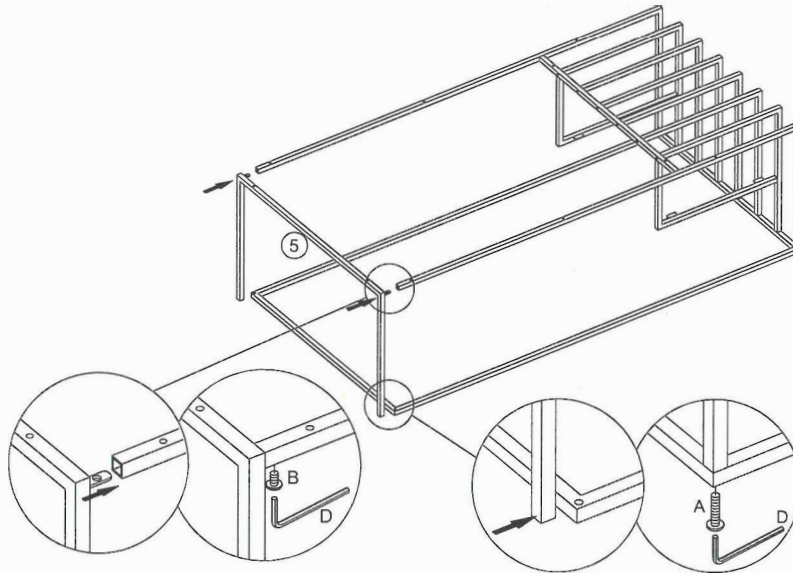

# STEP5

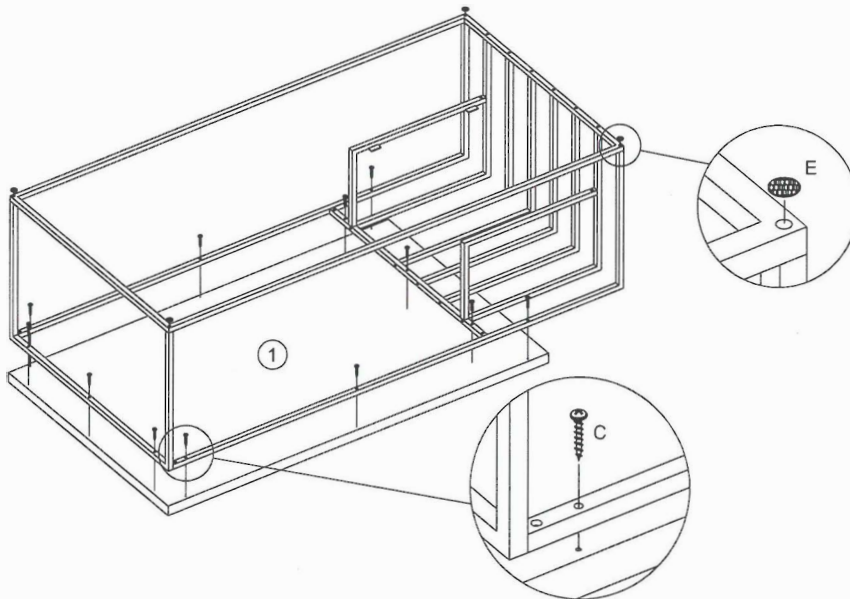

A	x2	B	x2	D	x1
					
M5*20mm		M5*8mm		M4	

# STEP6



C	x12	E	x4
			
M4*25mm		Φ 10*3mm	

# STEP7

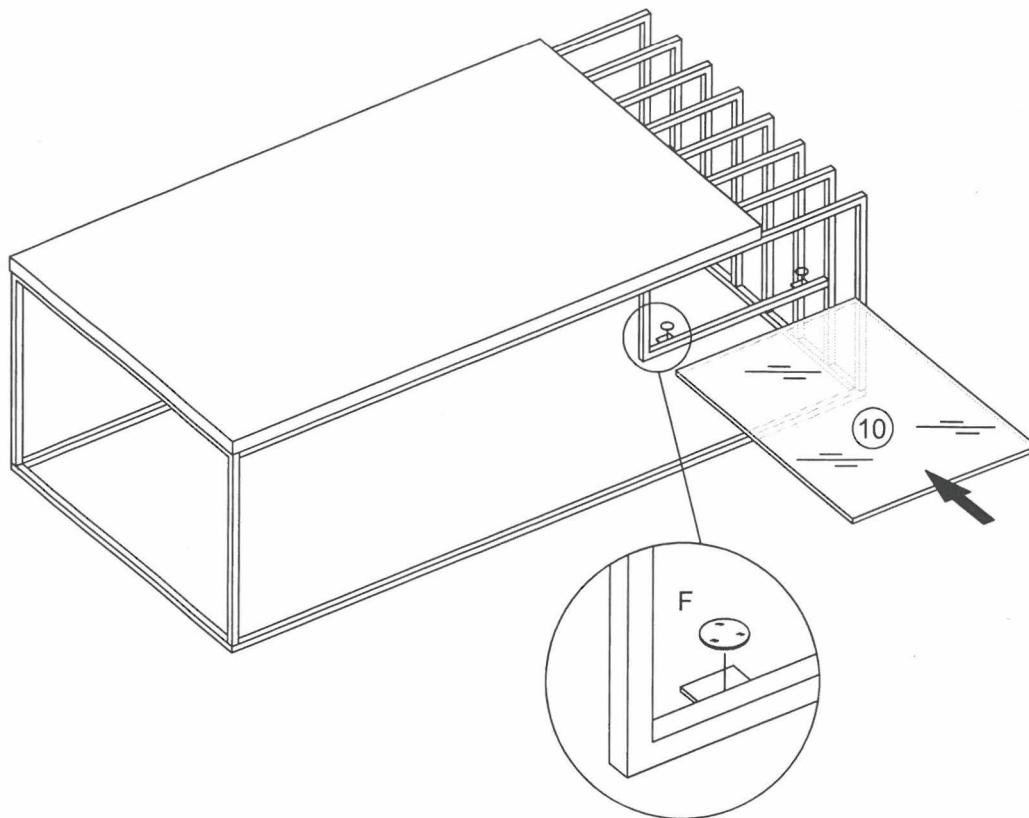

# STEP8

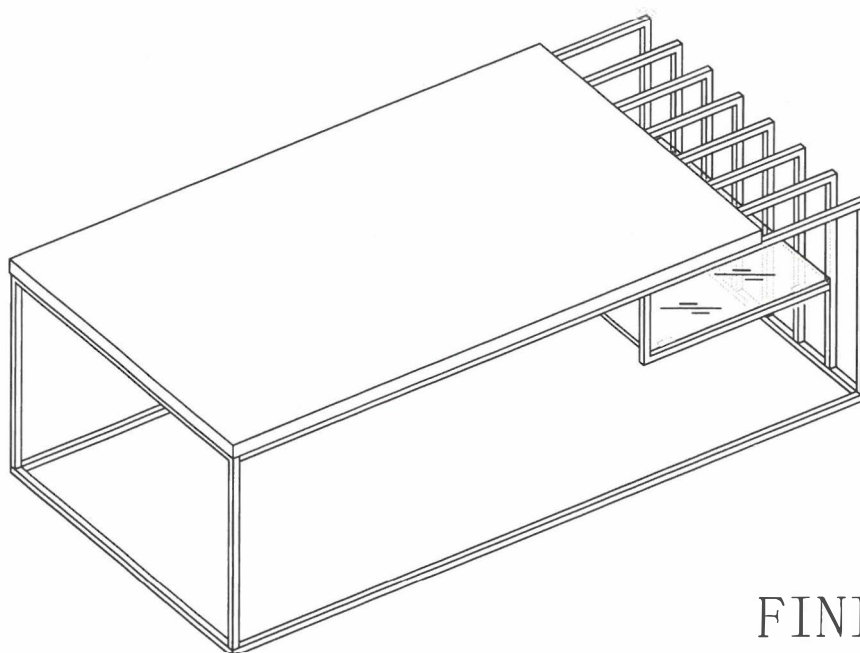

FINISH!