

ASMARA/67784

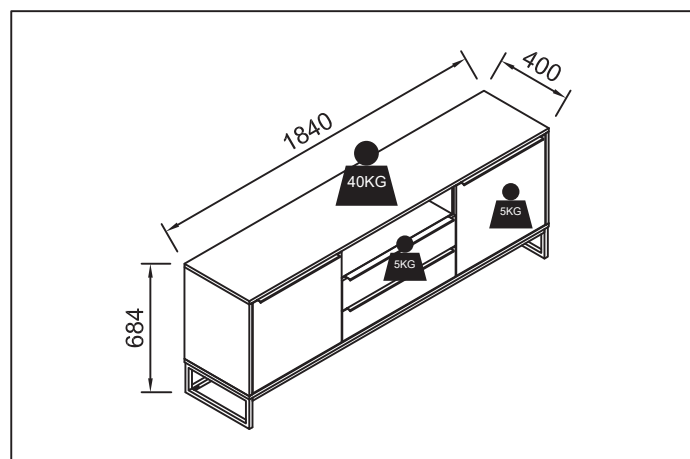

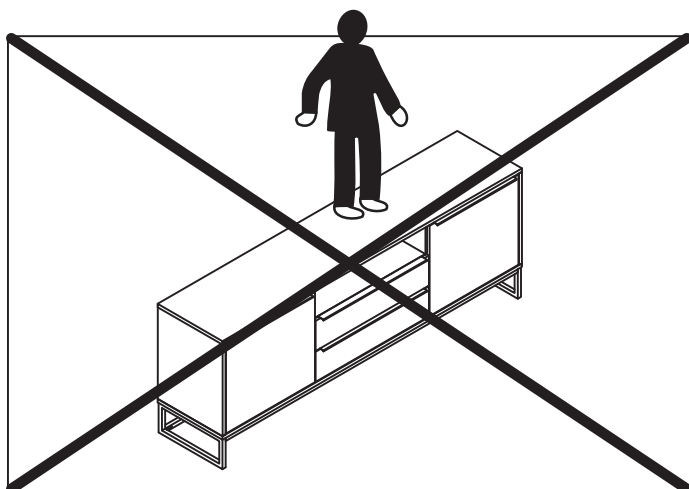

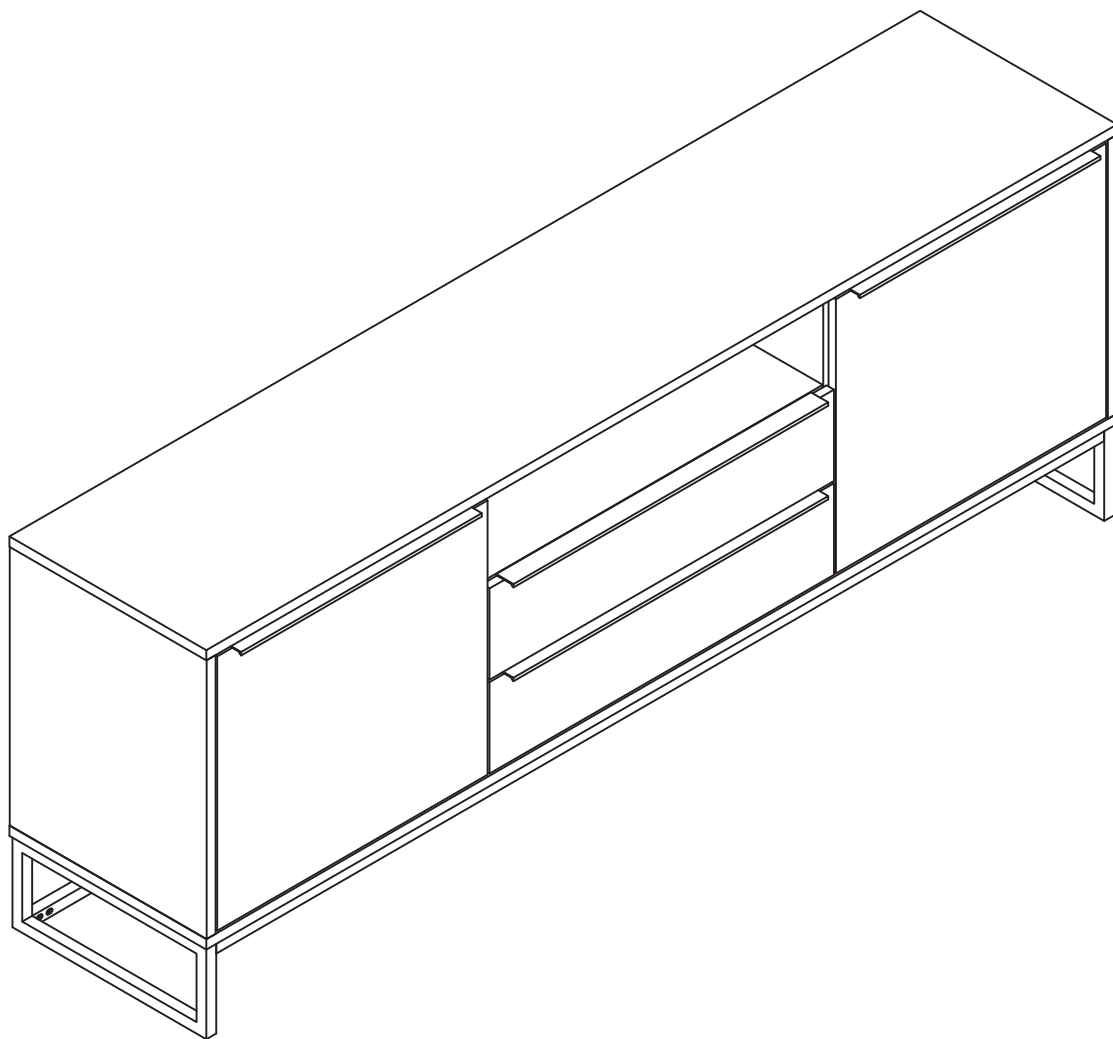

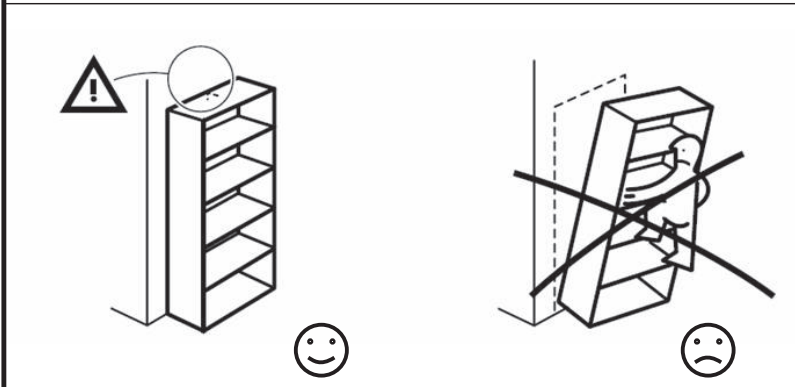
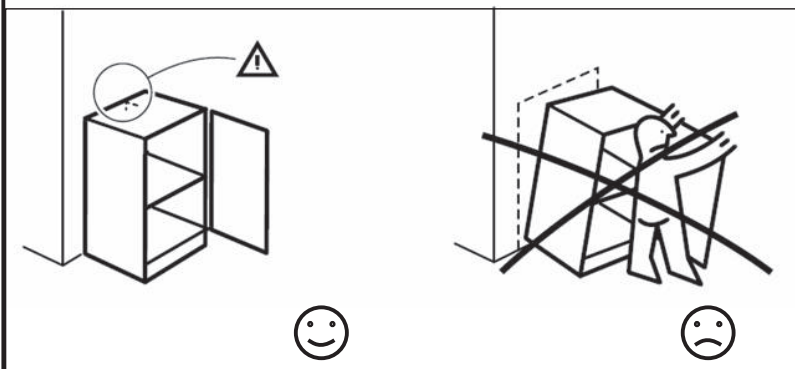
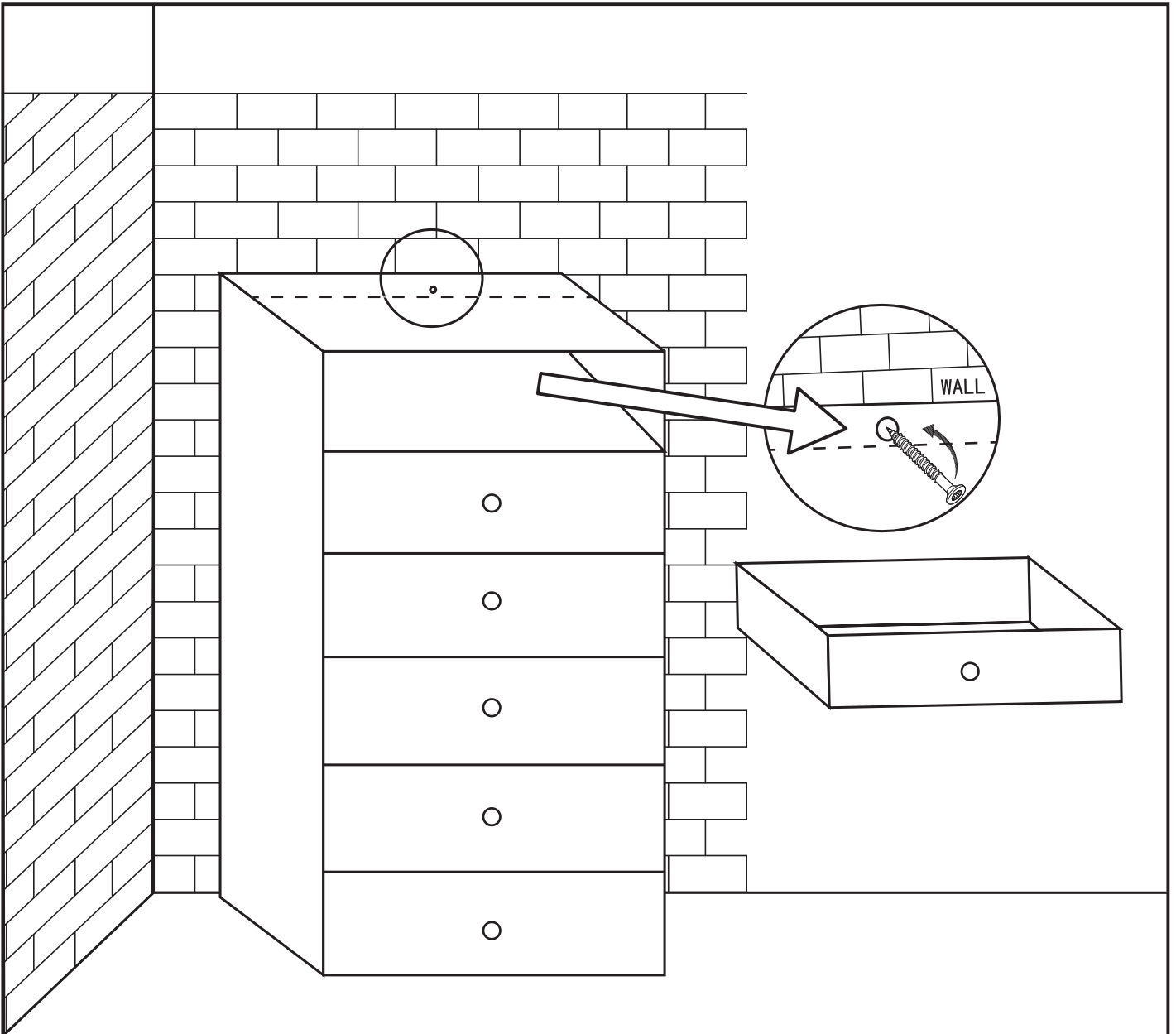
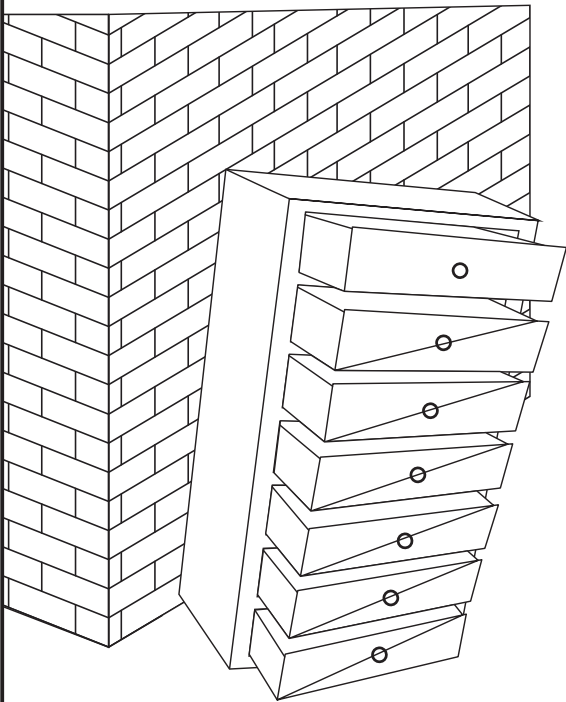
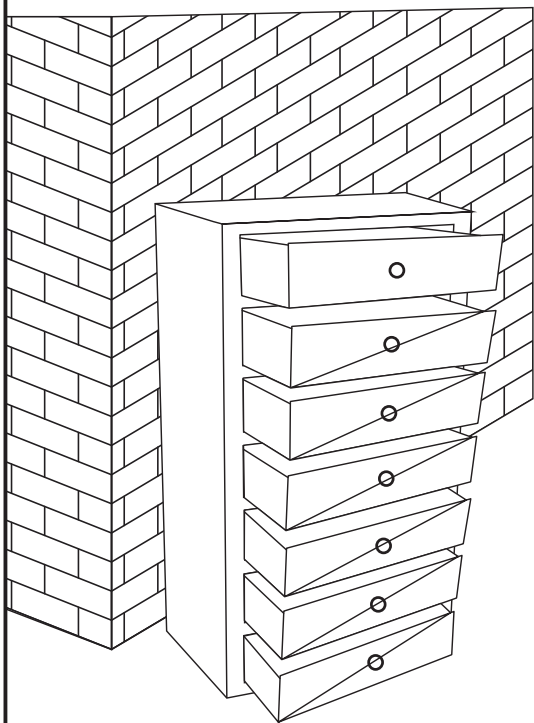
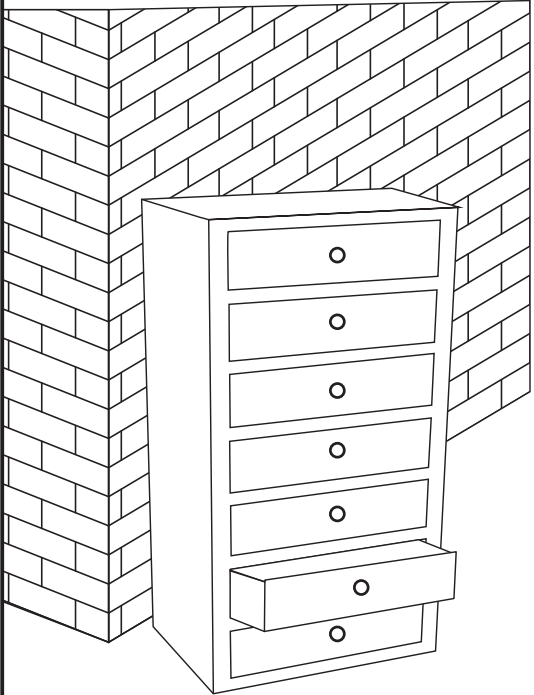
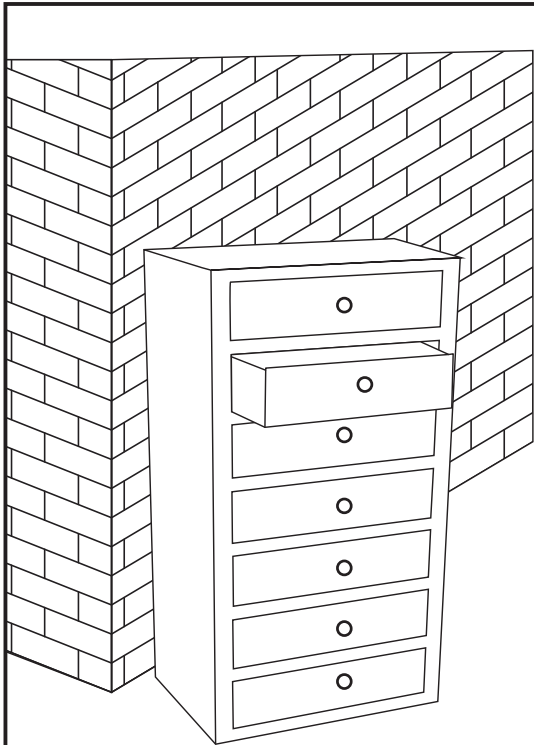
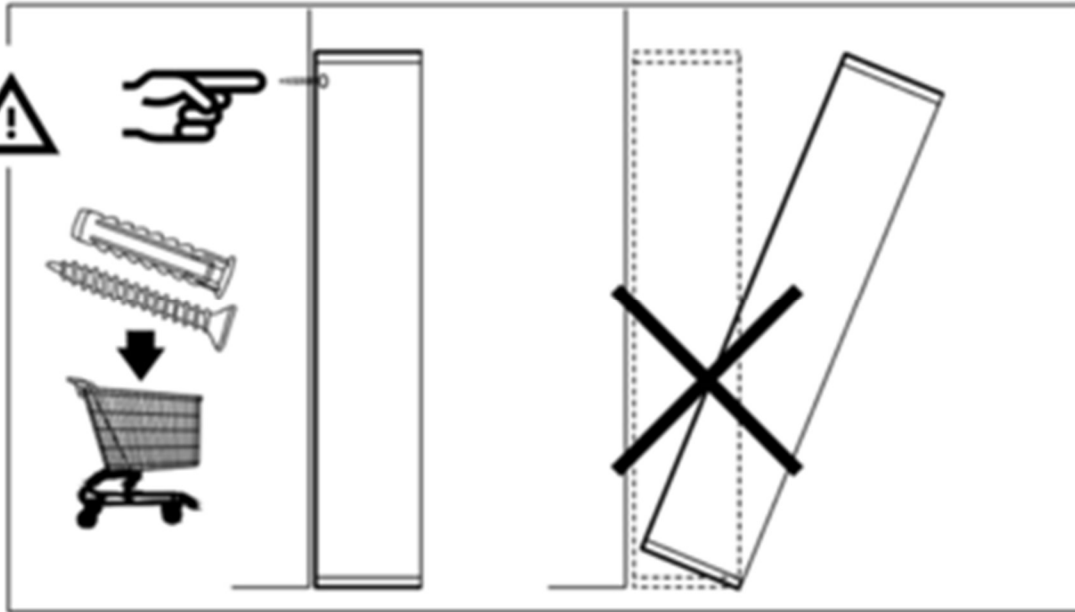

Wandbefestigung / wall mounting

DE German

Aus Sicherheitsgründen muss eine Kippsicherung angebracht werden. Bitte prüfen Sie zuerst die Beschaffenheit der Hauswand. Entsprechend der Beschaffenheit besorgen Sie bitte passende Materialien, wie Wanddübel und Schrauben, in einem Fachmarkt.

GB England

For safety reasons, an anti-tip device must be fitted. Please check the condition of the house wall first. According to the condition, please obtain suitable materials, such as wall plugs and screws, in a specialist store.

FR France

Pour des raisons de sécurité, un dispositif anti-basculement doit être installé. Veuillez d'abord vérifier la qualité du mur de la maison. En fonction de la qualité, veuillez vous procurer le matériel adéquat, comme les chevilles murales et les vis, dans un magasin spécialisé.

IT Italy

Per ragioni di sicurezza, un dispositivo antiribaltamento deve essere montato. Si prega di controllare prima le condizioni del muro della casa. A seconda delle condizioni, procuratevi i materiali adatti, come i tasselli e le viti, da un negozio specializzato.

NL Netherlands

Om veiligheidsredenen moet een anti-kantelinrichting worden aangebracht. Controleer eerst de staat van de huismuur. Afhankelijk van de toestand moet u geschikte materialen, zoals muurpluggen en schroeven, bij een speciaalzaak kopen.

DK Denmark

Af sikkerhedshensyn skal der monteres en anti-kipanordning.

Kontroller først husmurenes tilstand. Afhængigt af tilstanden skal du købe passende materialer, f.eks. vægpropper og skruer, i en specialforretning.

SE Sweden

Av säkerhetsskäl måste en tipskyddsanordning monteras.

Kontrollera först husväggens skick. Beroende på tillståndet ska du skaffa lämpliga material, t.ex. väggpluggar och skruvar, i en specialaffär.

NO Norway

Av sikkerhetsmessige årsaker må det monteres en vippesikring

Vennligst sjekk tilstanden til husveggen først. Avhengig av tilstanden, skaffe egnede materialer, som plugger og skruer, fra en faghandel.

FI Finland

Turvallisuussyistä on asennettava kallistumisenestolaite.

Av säkerhetsskäl har vi inte inkluderat något fästmaterial för antilutningsanordningen på husväggen.

Kontrollera först husväggens skick. Beroende på tillståndet ska du skaffa lämpliga material, t.ex. väggpluggar och skruvar, i en specialaffär.

ES Spain

Por razones de seguridad, debe instalarse un dispositivo antivuelco.

Por favor, compruebe primero el estado de la pared de la casa. Dependiendo del estado, obtenga los materiales adecuados, como tacos y tornillos, en una tienda especializada.

PT Portugal

Por razões de segurança, deve ser instalado um dispositivo antitombamento.

Por favor, verifique primeiro o estado da parede da casa. Dependendo da condição, por favor obter materiais adequados, tais como tampões e parafusos de parede, numa loja especializada.

PL Poland

Ze względów bezpieczeństwa należy zamontować urządzenie przeciwwywrotne.

Najpierw należy sprawdzić stan ścian domu. W zależności od stanu należy zaopatrzyć się w odpowiednie materiały, takie jak kołki rozporowe i wkręty, w specjalistycznym sklepie.

RU Russia

В целях безопасности необходимо установить устройство против опрокидывания.

Пожалуйста, сначала проверьте состояние стены дома. В зависимости от состояния, пожалуйста, приобретите подходящие материалы, такие как дюбели и шурупы, в специализированном магазине.

SK Slovakia

Z bezpečnostných dôvodov sa musí namontovať zariadenie proti prevráteniu. Najprv skontrolujte stav steny domu. V závislosti od stavu si v špecializovanom obchode zaobstarajte vhodné materiály, ako sú hmoždinky a skrutky.

CZ Czech Republic

Z bezpečnostných dôvodů je nutné namontovat zařzení proti převrácení. Nejprve zkontrolujte stav stěny domu. V závislosti na stavu si ve specializovaném obchodě opatřete vhodné materiály, jako jsou hmoždinky a šrouby.

SL Slovenia

Iz varnostnih razlogov je treba namestiti napravo proti prevračanju. Najprej preverite stanje hišne stene. V specializirani trgovini si glede na stanje priskrbite ustrezne materiale, kot so zidni čepi in vijaki.

HU Hungary

Biztonsági okokból fel kell szerelni egy felborulásgátlót. Kérjük, először ellenőrizze a házfal állapotát. Az állapottól függően, kérjük, szerezze be a megfelelő anyagokat, mint például a faldugókat és csavarokat, egy szaküzletben.

BG Bulgaria

От съображения за безопасност трябва да се монтира устройство против преобръщане. Първо проверете състоянието на стената на къщата. В зависимост от състоянието, моля, набавете подходящи материали, като дюбели и винтове, от специализиран магазин.

RO Romania

Din motive de siguranță, trebuie montat un dispozitiv anti-înclinare. Vă rugăm să verificați mai întâi starea peretelui casei. În funcție de starea în care se află, vă rugăm să vă procurați materiale adecvate, cum ar fi dopuri de perete și șuruburi, de la un magazin specializat.

TR Turkey

Güvenlik nedeniyle, devrilme önleyici bir cihaz kurulmalıdır. Lütfen önce evin duvarının durumunu kontrol edin. Duruma bağlı olarak lütfen özel bir mağazadan dübel ve vida gibi uygun malzemeleri temin edin.

GR Greece

Για λόγους ασφαλείας, πρέπει να τοποθετηθεί μια διάταξη κατά της ανατροπής. Ελέγξτε πρώτα την κατάσταση του τοίχου του σπιτιού. Ανάλογα με την κατάσταση του τοίχου, προμηθευτείτε τα κατάλληλα υλικά, όπως βύσματα και βίδες, από ένα εξειδικευμένο κατάστημα.

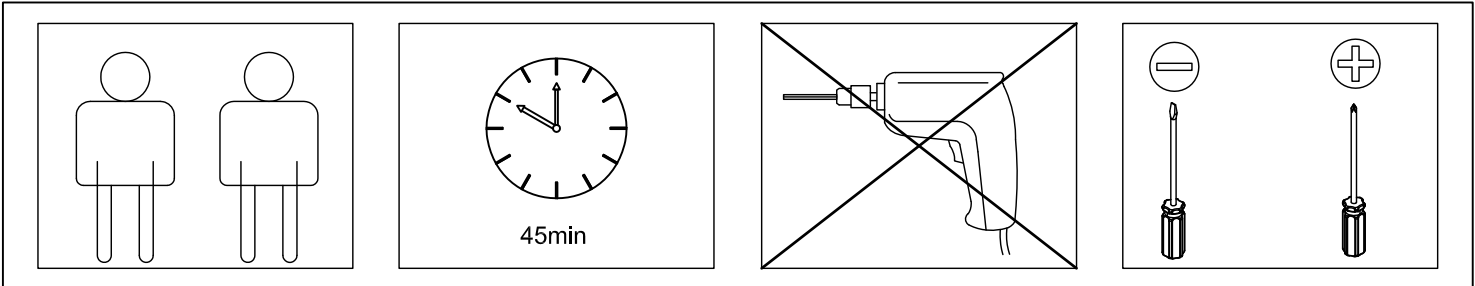
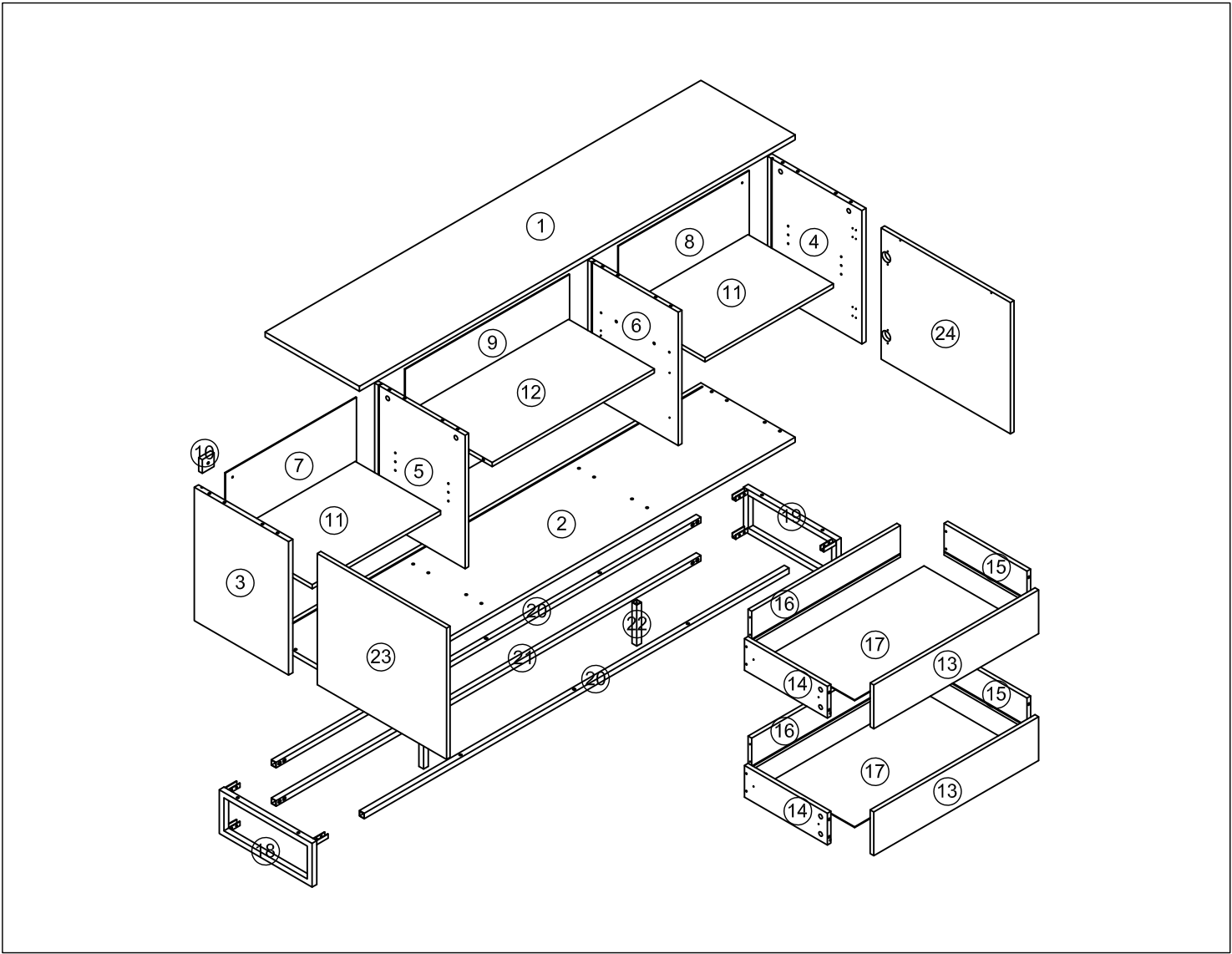

A	x 20	B	x 12	C	x 12	D	x 12	E	x 24	F	x 8
Ø7.8*30mm		M6*36mm		Ø15*12mm		14*14*9mm		Ø4*15mm		Ø4*30mm	
G	x 8	H	x 4	J	x 4	K	x 1	L	x 22	M	x 12
M7*50mm		350mm		350mm		M4		φ16*φ6.5*1mm		M6*12mm	
N	x 10	P	x 4	Q	x 36	R	x 2	S	x 4	T	x 8
M6*30mm		30*15*5mm		Ø3.5*12mm		635*35*15mm		Ø35mm		Ø5*14mm	
U	x 2	V	x 8	W	x 2	X	x 2	Y	x 8		
M6*35mm		M6*25mm		M6*20mm		485*35*15mm		Ø10*10mm			

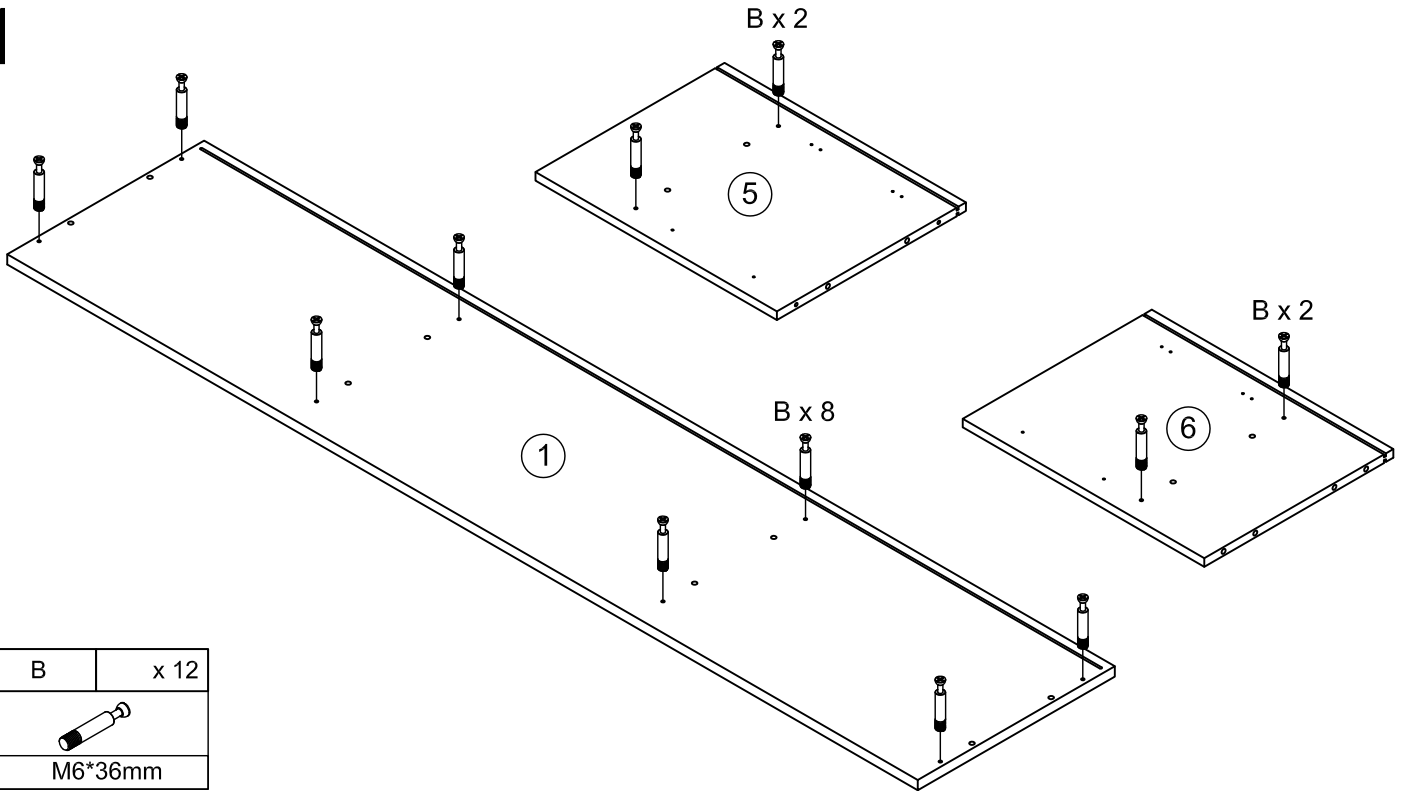

1



B	x 12
	
M6*36mm	

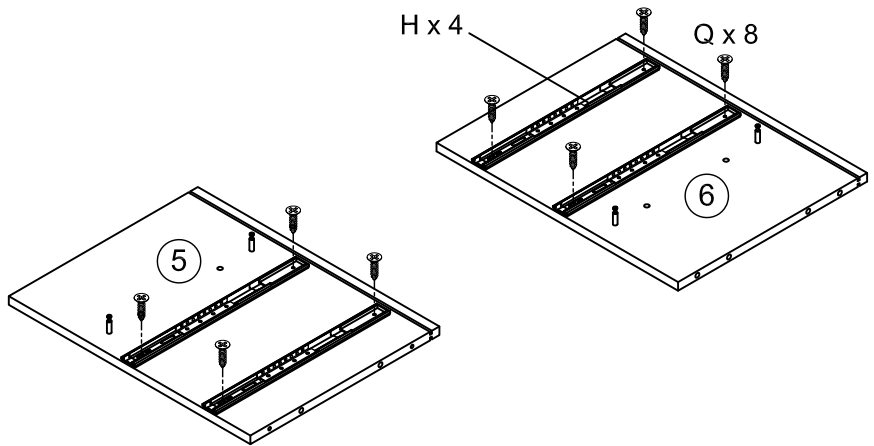
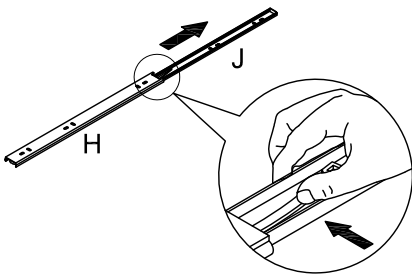

2



Q	x 8	H	x 4
			
Ø3.5*12mm		350mm	

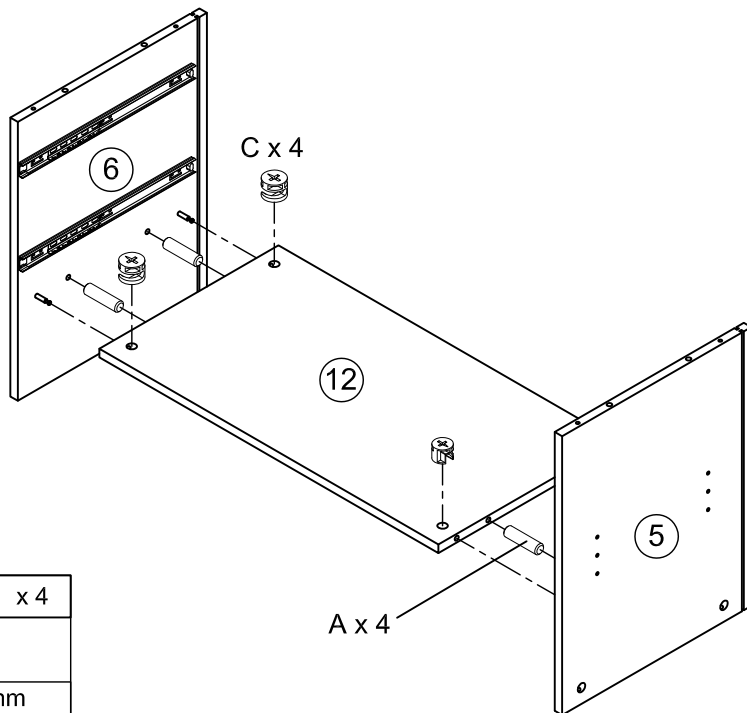

3

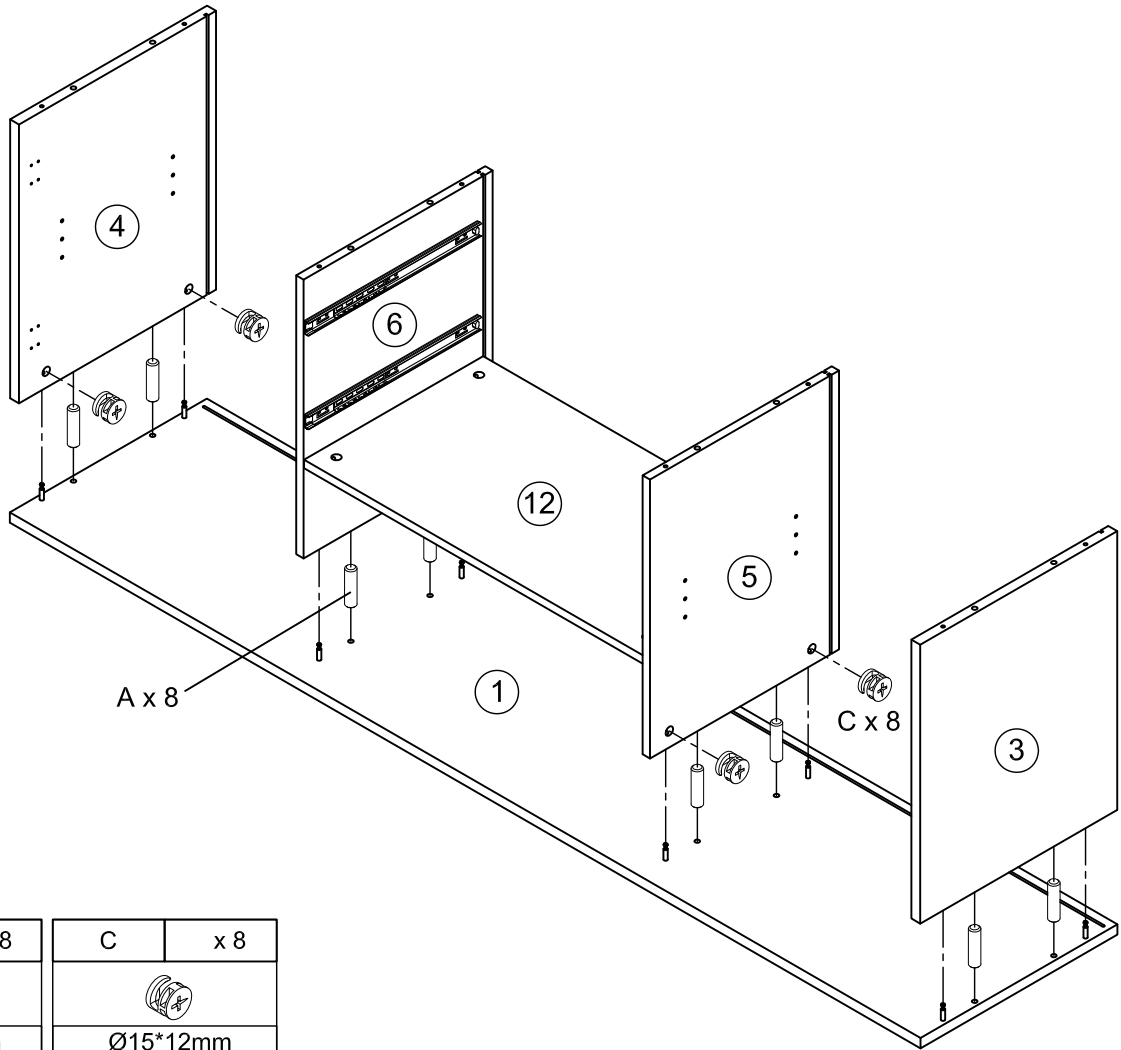

A	x 4	C	x 4
			
Ø7.8*30mm		Ø15*12mm	

4



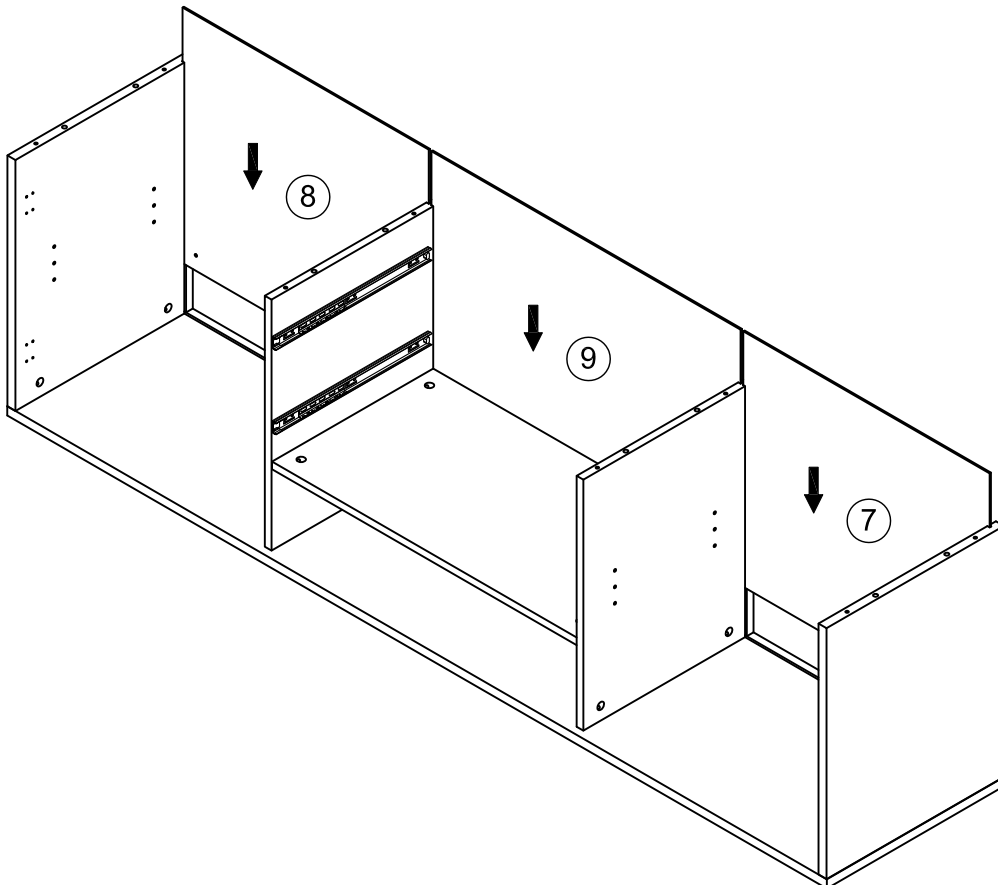

A	x 8	C	x 8
			
Ø7.8*30mm		Ø15*12mm	

5

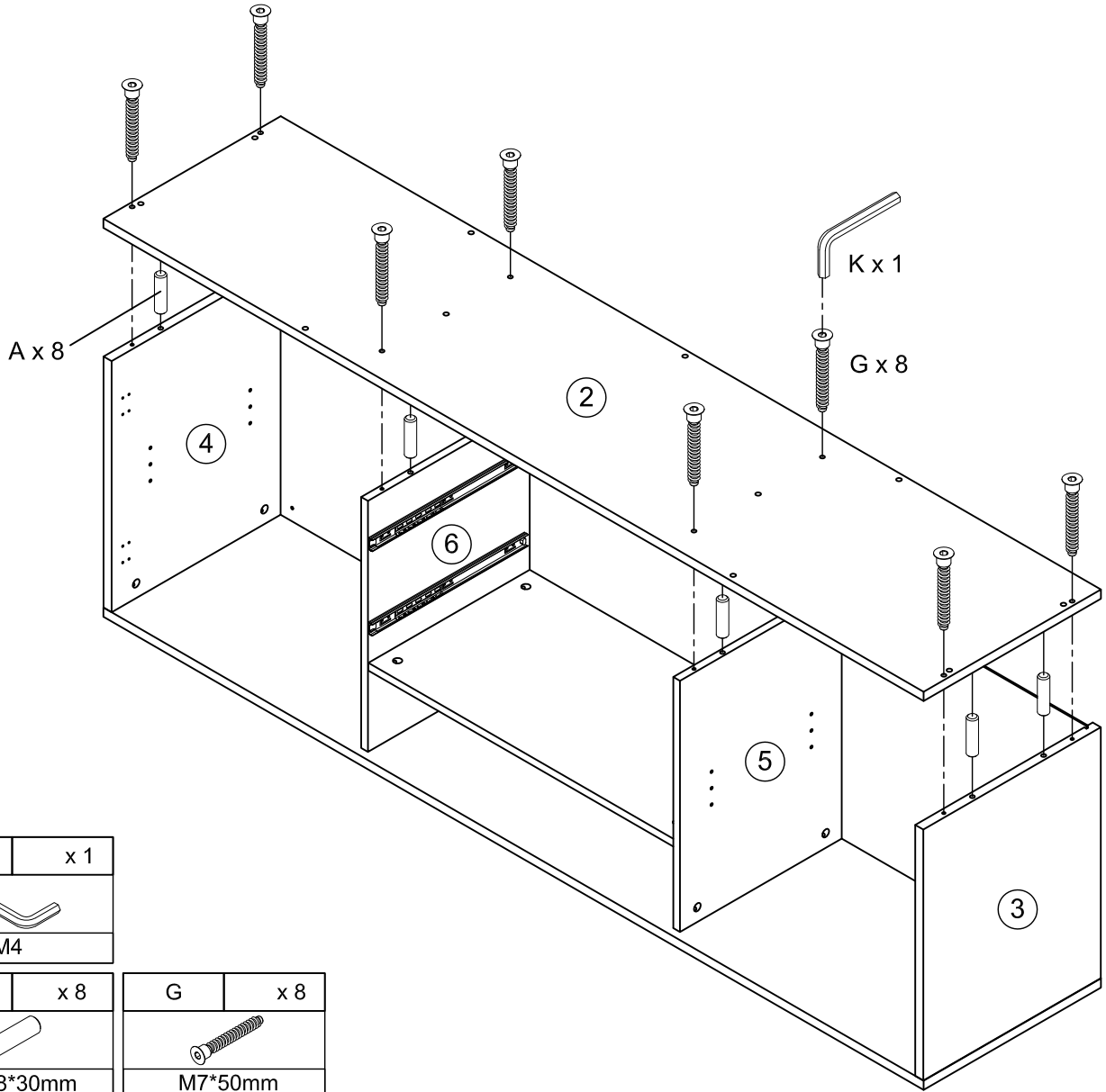

6





K	x 1
	
M4	

A	x 8
	
Ø7.8*30mm	

G	x 8
	
M7*50mm	

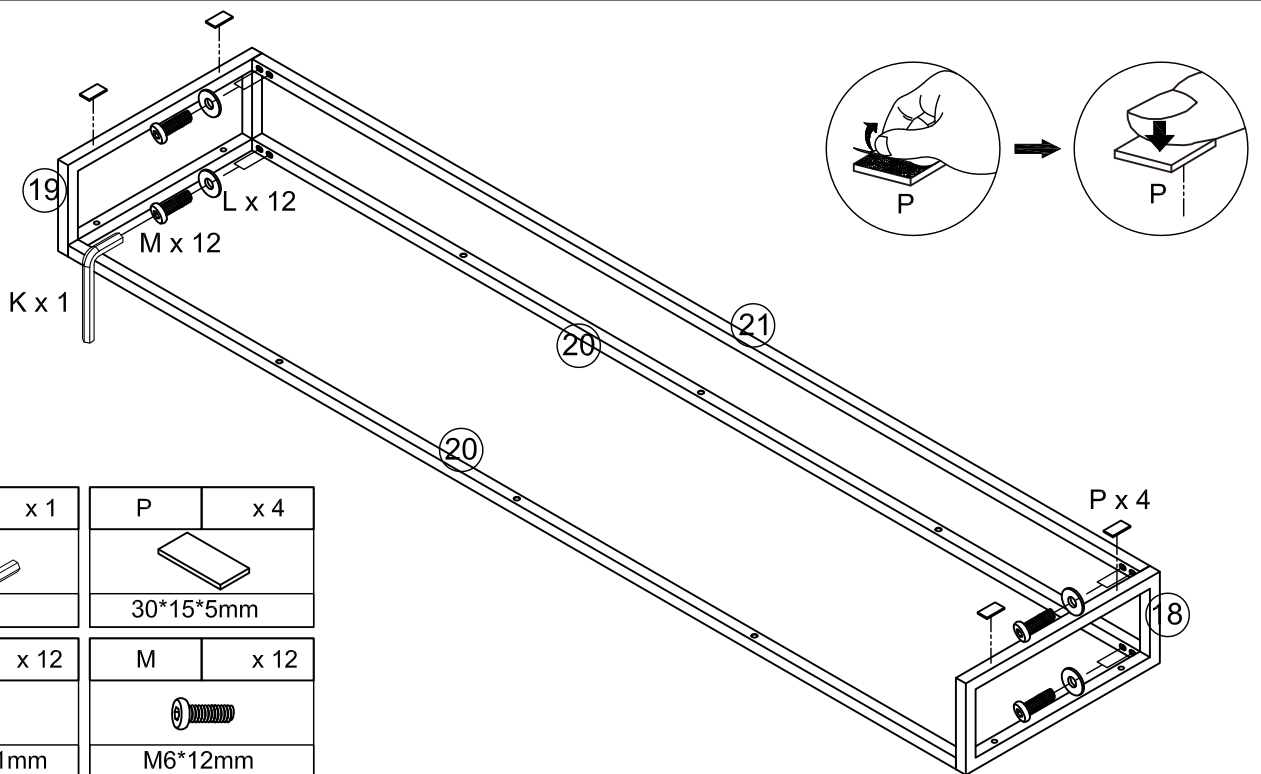
7

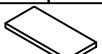

K	x 1
	
M4	

P	x 4
	
30*15*5mm	

L	x 12
	
Ø16*Ø6.5*1mm	

M	x 12
	
M6*12mm	

8

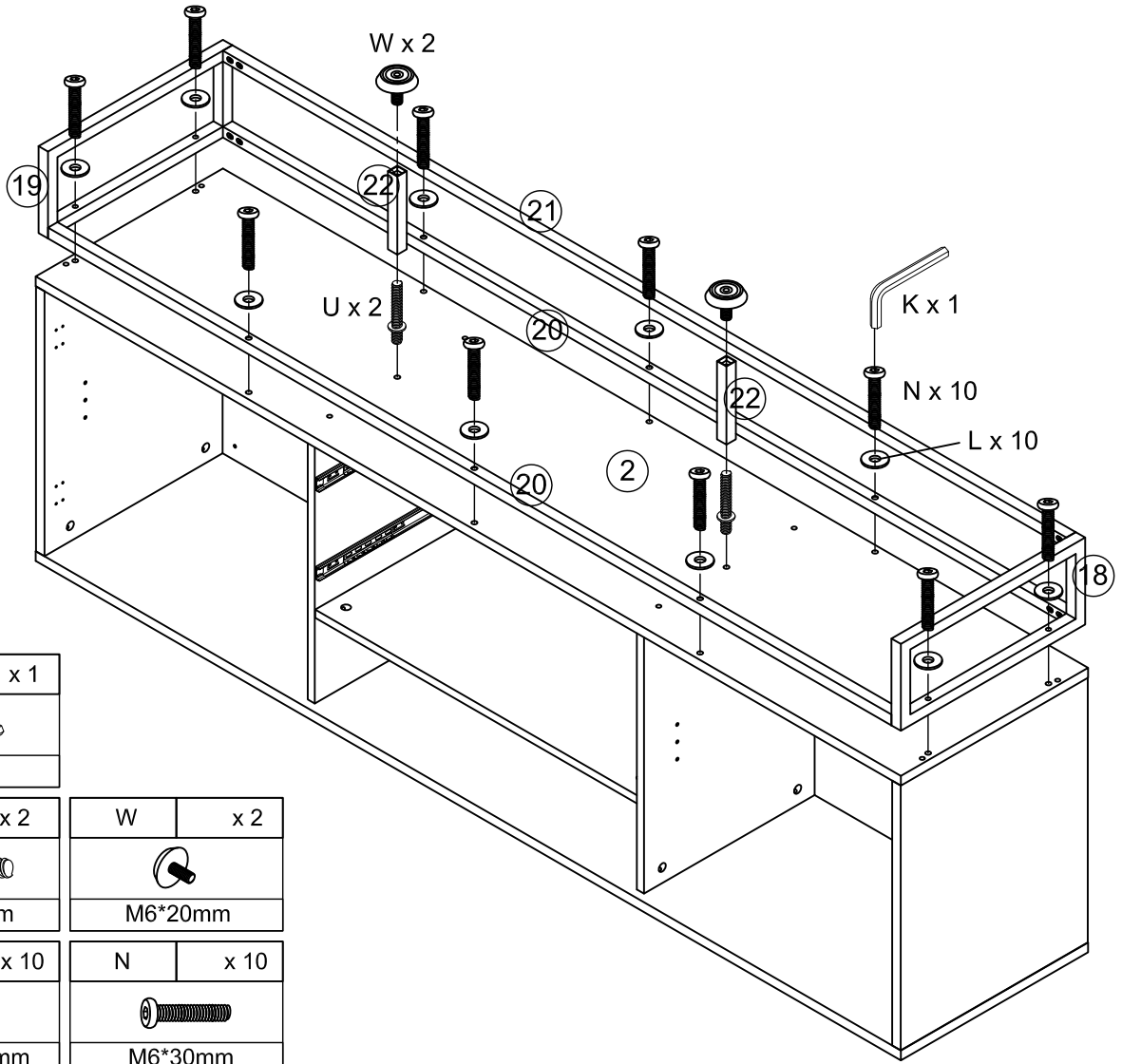

K	x 1
M4	

U	x 2
M6*35mm	

W	x 2
M6*20mm	

L	x 10
φ16*φ6.5*1mm	

N	x 10
M6*30mm	

9

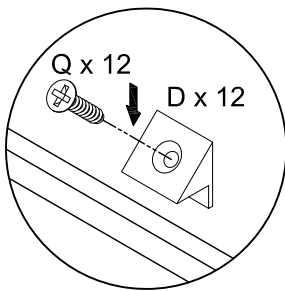
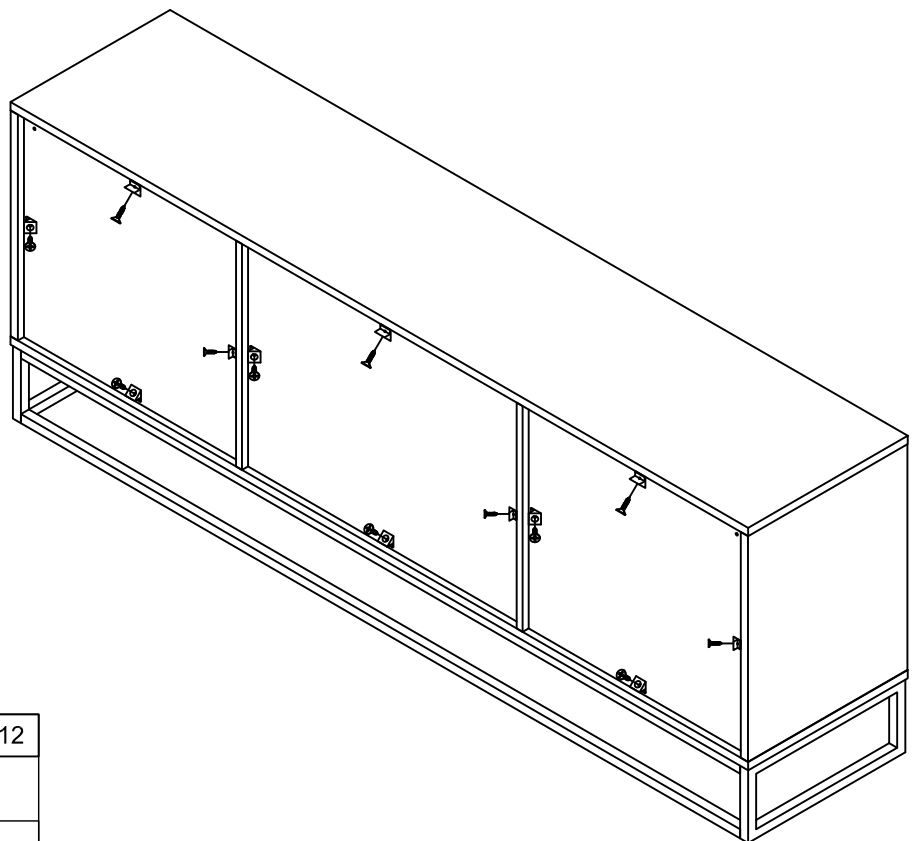

Q	x 12
Ø3.5*12mm	

D	x 12
14*14*9mm	

10

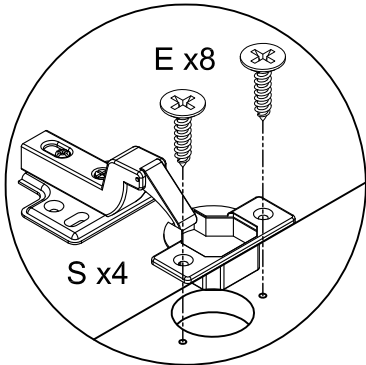

Q	x 4	X	x 2
Ø3.5*12mm		485*35*15mm	
E	x 8	S	x 4
Ø4*15mm		Ø35mm	

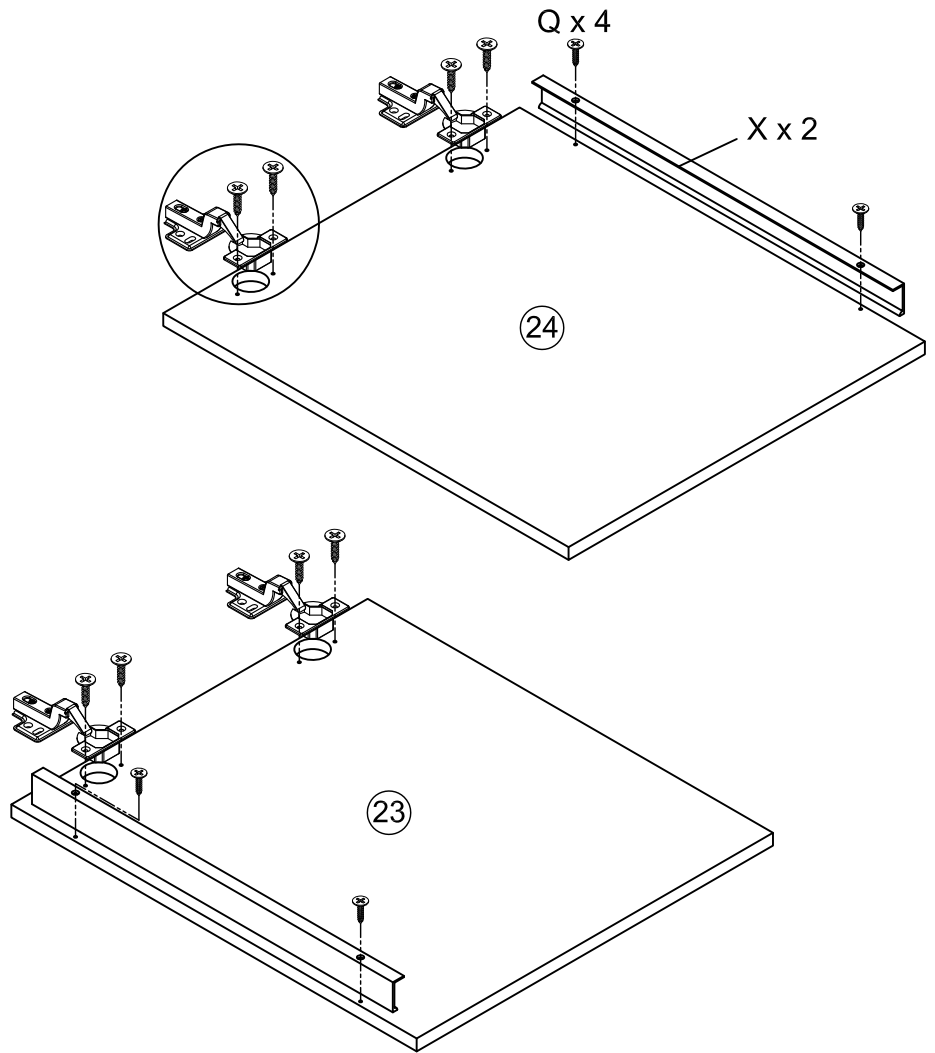

11

V	x 8	Q	x 4	R	x 2
M6*25mm		Ø3.5*12mm		635*35*15mm	

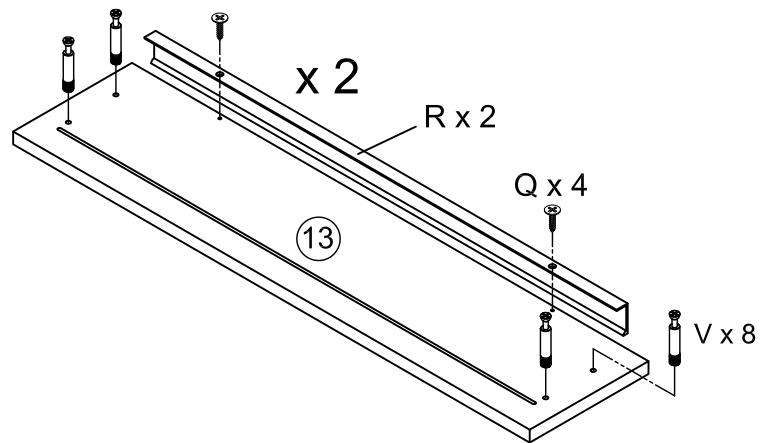

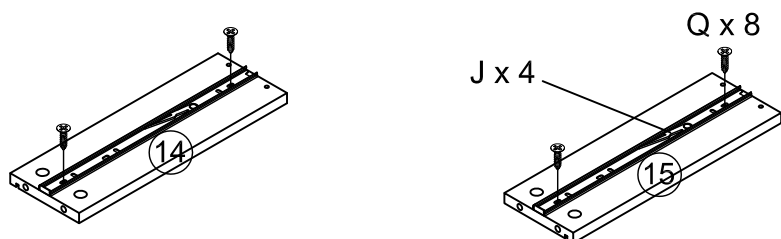

12

Q	x 8	J	x 4
Ø3.5*12mm		350mm	

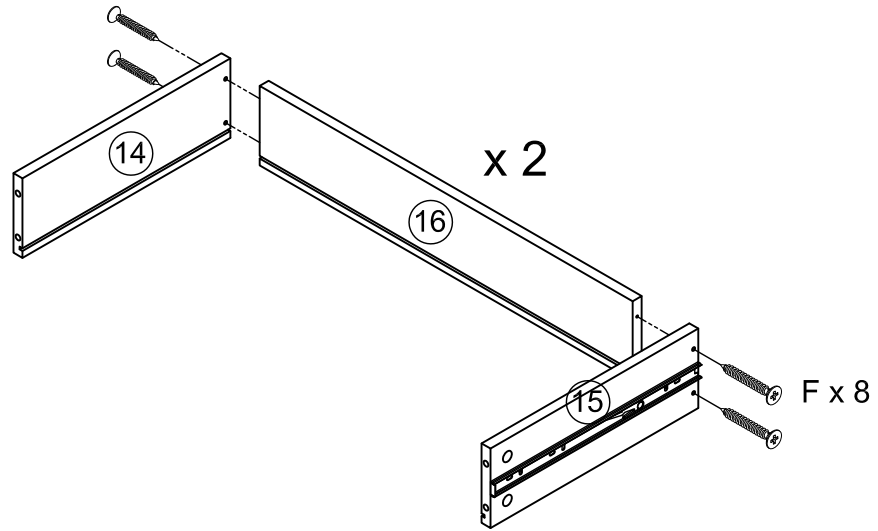

13



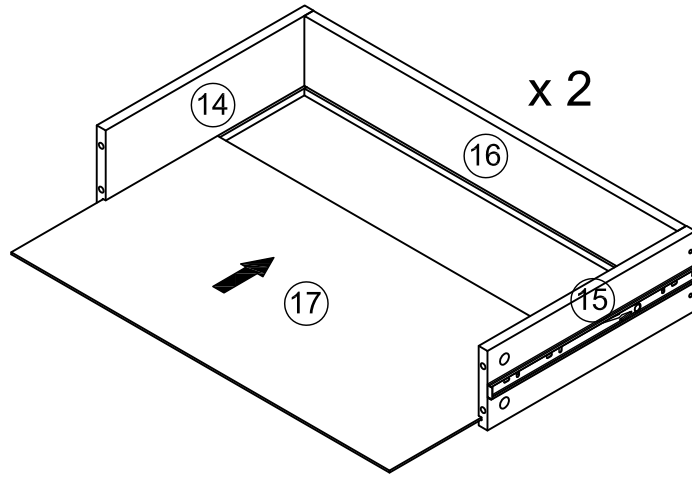

F	x 8
	
Ø4*30mm	

14

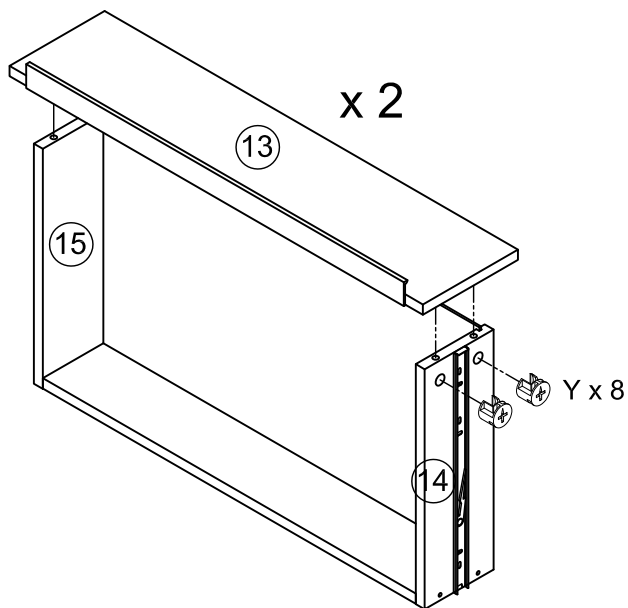

15



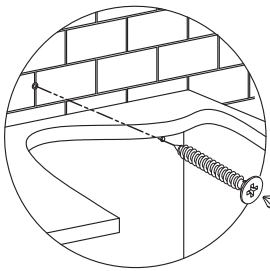
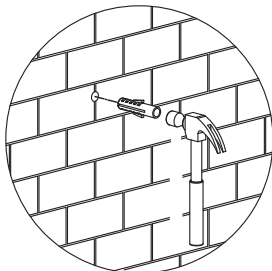
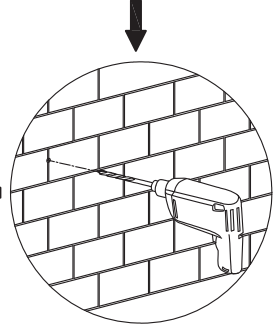
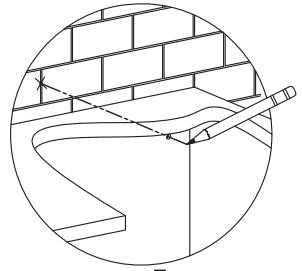
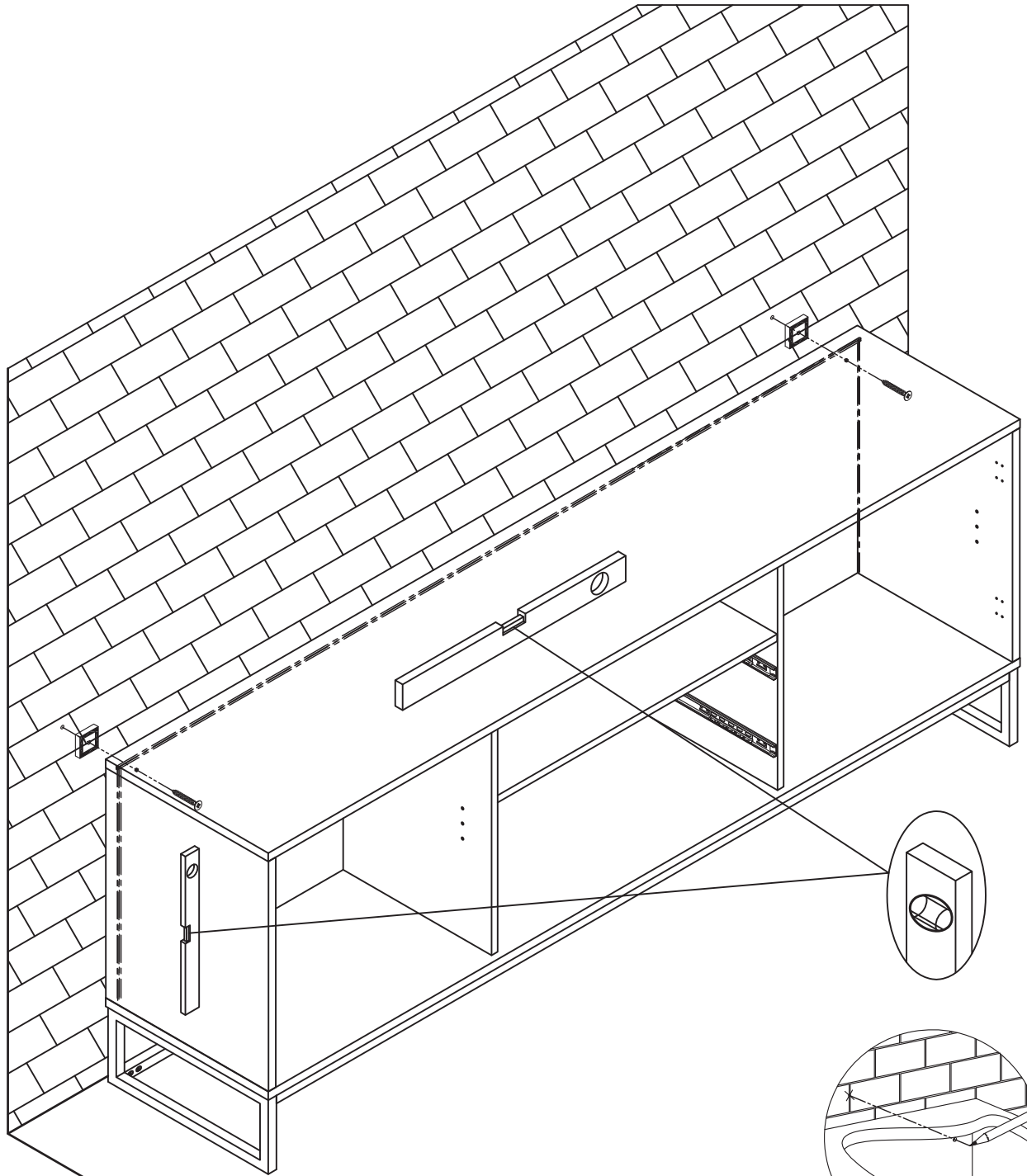

Y	x 8
	
Ø10*10mm	

16

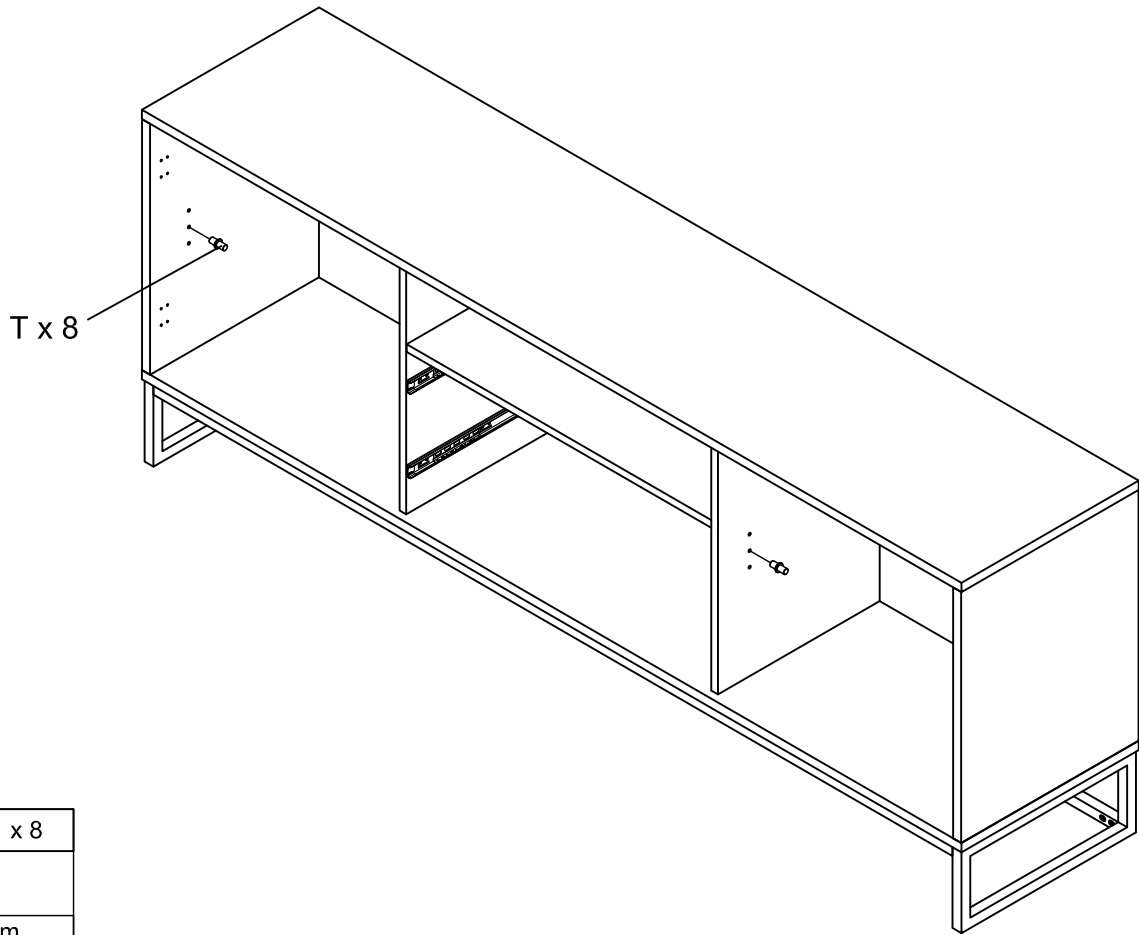

17



T	x 8
	
Ø5*14mm	

18

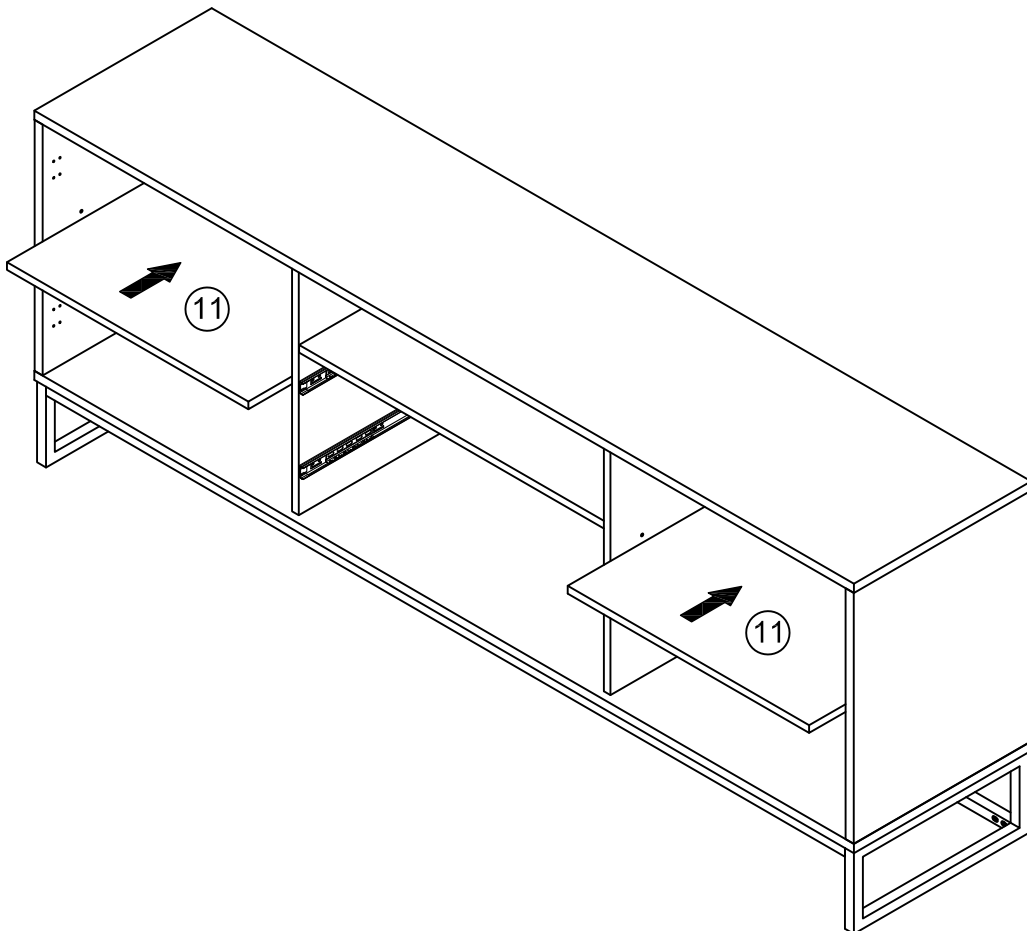

19

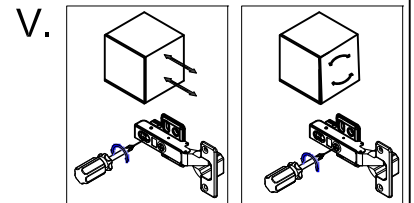
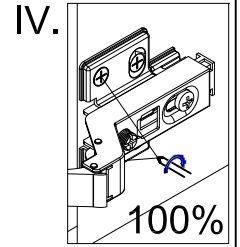
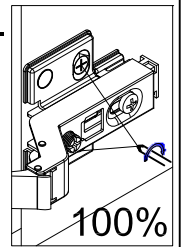
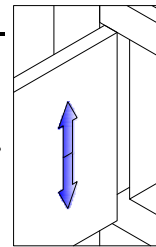
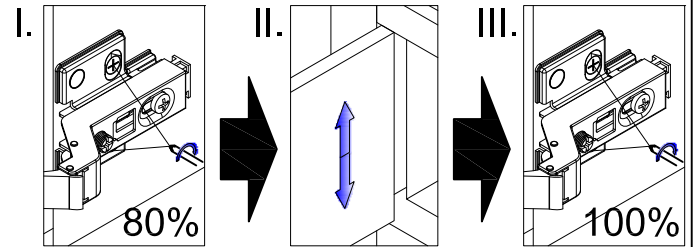
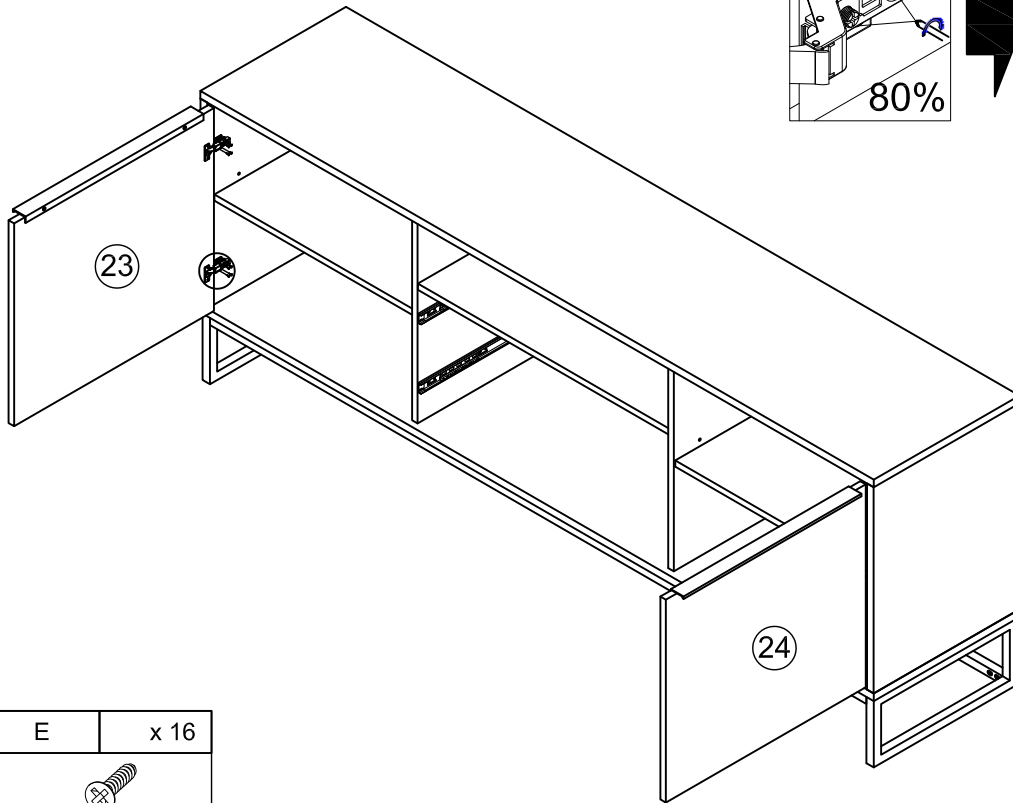

E	x 16
$\text{Ø}4*15\text{mm}$	

20

