

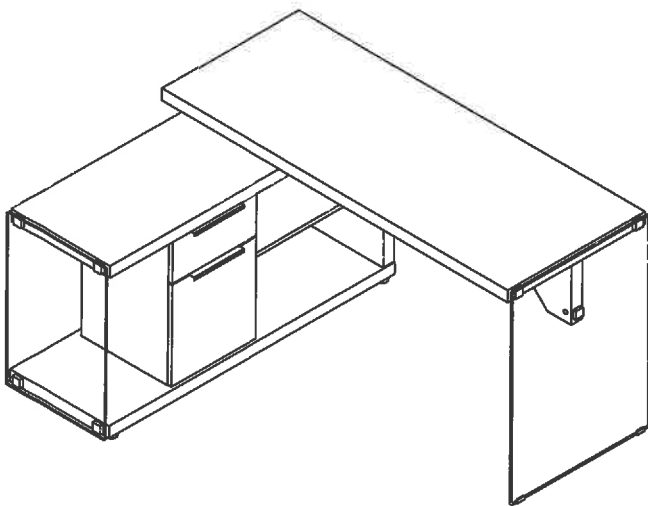

Jahnke

CGL 150 E



L

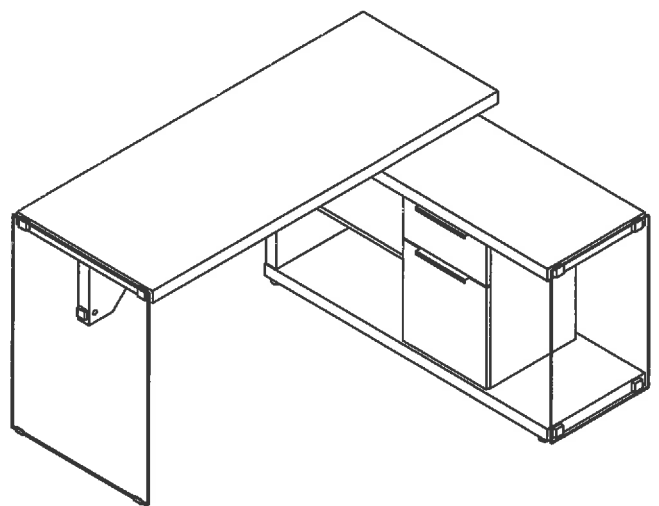

R

DE Herzlichen Glückwunsch zu Deinem neuen Jahnke-Möbel!
Wir bedanken uns für Deinen Kauf und hoffen, daß Du mit Deiner Wahl zufrieden bist. Damit Du lange Freude an diesem guten Stück hast, bitten wir Dich vor der Montage die Anleitung und Pflegehinweise sorgfältig durch zu lesen und die Reihenfolge einzuhalten.

Pflegehinweise:

Wichtige Informationen zur Pflege und Nutzung von Deinem neuen Möbel:

Schütze Dein Möbel vor direkter Sonneneinstrahlung, extremer Lichteinwirkung und Hitze. Stoffe und Oberflächen können ausbleichen, da eine 100%ige Lichtechtheit nicht zu erreichen ist. Benutze dieses Möbel nicht im Aussenbereich. Setze dieses Möbel nicht zu hoher Luftfeuchte aus und Sorge für eine stabile Temperatur. Heiße Gegenstände dürfen nicht direkt auf Oberflächen gestellt werden. Zur Reinigung von Holz, Metall und Glasoberflächen nur mit leicht feuchtem Tuch wischen und sofort trocken nachwischen. Benutze keinen scharfen Putz- oder Reinigungsmittel. Polstermöbel:

Zur Reinigung von Textilbezüge diese lediglich sanft absaugen. Auf keinen Fall scharfe Reinigungsmittel benutzen oder Bleichmittel einsetzen. Bei Essens- oder Getränke. Um Gebrauchsspuren zu reduzieren, wende Polster/Kissen regelmäßig, sofern diese wendbar sind.

FR Félicitations pour vos nouveaux meubles Jahnke!
Nous vous remercions pour votre achat et espérons que vous serez satisfait de votre choix.
Afin de profiter de cette bonne pièce pendant longtemps, nous vous demandons de lire attentivement les instructions et les instructions d'entretien avant le montage et de respecter l'ordre.

Conseils d'entretien:

Informations importantes pour l'entretien et l'utilisation de votre nouveau mobilier: Protégez vos meubles des rayons directs du soleil, de la lumière extrême et de la chaleur. Les substances et les surfaces peuvent s'estomper, car une résistance à la lumière de 100% ne peut pas être obtenue. Ne pas utiliser ce meuble en extérieur. Ne pas exposer ce meuble à une humidité élevée et assurer une température stable Les objets chauds ne doivent pas être placés directement sur les surfaces. Pour nettoyer les surfaces en bois, en métal et en verre, essuyez-les immédiatement avec un chiffon humide. N'utilisez pas de détergent puissant.

Meubles rembourrés:

Pour nettoyer les housses textiles, il suffit de les aspirer. N'utilisez jamais de détergents ni d'eau de Javel. Pour la nourriture ou des boissons. Pour réduire l'usure, utilisez des coussins / coussins régulièrement, tant qu'ils sont réversibles.

ES ¡Felicidades por tus nuevos muebles Jahnke!
Le agradecemos su compra y esperamos que esté satisfecho con su elección. Para disfrutar de esta buena pieza durante mucho tiempo, le pedimos que lea atentamente las instrucciones y las instrucciones de cuidado antes del montaje y que observe el pedido.

Mantenimiento:

Información importante para el cuidado y uso de sus nuevos muebles: Proteja sus muebles de la luz solar directa, la luz extrema y el calor. Las sustancias y las superficies pueden desvanecerse, ya que no se puede lograr una resistencia a la luz del 100%. No uses este mueble al aire libre. No exponga este mueble a humedad elevada y asegúrese de mantener una temperatura estable. Los objetos calientes no deben colocarse directamente sobre las superficies. Para limpiar superficies de madera, metal y vidrio, limpie con un paño húmedo y seque inmediatamente. No utilice un agente de limpieza fuerte o de limpieza.

muebles tapizados:

Para limpiar las cubiertas textiles, simplemente aspiralas. Nunca use detergentes fuertes o lejía. Para comida o bebidas. Para reducir el desgaste, use almohadillas / cojines regularmente, siempre que sean reversibles.

NL Gefeliciteerd met je nieuwe Jahnke-meubels!
Wij danken u voor uw aankoop en hopen dat u tevreden bent met uw keuze. Om lang van dit goede stuk te kunnen genieten, vragen wij u om de instructies en onderhoudsinstructies zorgvuldig te lezen vóór de montage en om de bestelling te observeren.

Onderhoud:

Belangrijke informatie voor de verzorging en het gebruik van uw nieuwe meubels: Bescherm uw meubels tegen direct zonlicht, extreme lichtinval en hitte. Stoffen en oppervlakken kunnen vervagen, omdat een 100% lichtechtheid niet kann worden bereikt. Gebruik dit meubilair niet buitenshuis. Stel dit meubel niet bloot aan hoge luchtvochtigheid en zorg voor een stabiele temperatuur. Hete voorwerpen mogen niet rechtstreeks op oppervlakken worden geplaatst. Om hout, metaal en glasoppervlakken te reinigen, veegt u af met een vochtige doek en wrijft u onmiddellijk droog. Gebruik geen sterke schoonmaak- of reinigingsmiddelen.

Gestoffeerde meubels:

Om textielbekledingen schoon te maken, zuigt u ze eenvoudigweg af. Gebruik nooit agressieve schoonmaakmiddelen of bleekmiddelen. Voor eten of drinken Gebruik pads / kussens regelmatig om slijtage te verminderen, zolang ze maar omkeerbaar zijn.

GB Congratulations on your new Jahnke furniture!
We thank you for your purchase and hope that you are satisfied with your choice. In order to enjoy this good piece for a long time, we ask you to carefully read the instructions and care instructions before assembly and to observe the order.

Care instructions:

Important information for the care and use of your new furniture:

Protect your furniture from direct sunlight, extreme light and heat. Substances and surfaces can fade, as a 100% light fastness can not be achieved. Do not use this furniture outdoors. Do not expose this furniture to high humidity and ensure a stable temperature. Hot objects must not be placed directly on surfaces. To clean wood, metal and glass surfaces, wipe with a damp cloth and wipe dry immediately. Do not use a strong cleaning or cleaning agent.

Upholstered furniture:

To clean textile covers, simply vacuum them off. Never use harsh detergents or bleach. For food or drinks. To reduce wear, use pads / cushions regularly, as long as they are reversible.

IT Congratulazioni per i tuoi nuovi mobili Jahnke!
Vi ringraziamo per il vostro acquisto e speriamo che siate soddisfatti della vostra scelta. Per godere a lungo di questo buon pezzo, vi preghiamo di leggere attentamente le istruzioni e le istruzioni di cura prima dell'assemblaggio e di osservare l'ordine.

Istruzioni per la cura:

Informazioni importanti per la cura e l'uso dei tuoi nuovi mobili:

Proteggi i tuoi mobili dalla luce diretta del sole, da luce e calore estremi. Sostanze e superfici possono sbiadire, poiché non è possibile raggiungere una resistenza alla luce al 100%. Non usare questo mobile all'aperto. Non esporre questi mobili a umidità elevata e garantire una temperatura stabile. Gli oggetti caldi non devono essere posizionati direttamente sulle superfici. Per pulire superfici in legno, metallo e vetro, pulire con un panno umido e asciugare immediatamente. Non utilizzare detergenti o detergenti aggressivi.

Mobili imbottiti:

Per pulire le coperture in tessuto, è sufficiente pulirle. Non usare mai detergenti aggressivi o candeggina. Per cibo o bevande. Per ridurre l'usura, usare regolarmente pastiglie / cuscini, purché siano reversibili.

PT Parabéns pela sua nova mobília Jahnke!
Agradecemos sua compra e esperamos que você esteja satisfeito com sua escolha. Para aproveitar esta boa peça por um longo tempo, pedimos que você leia atentamente as instruções e instruções de cuidados antes da montagem e observe o pedido.

Instruções de cuidados:

Informações importantes para o cuidado e uso de seu novo móvel:

Proteja seus móveis da luz solar direta, luz e calor extremos. Substâncias e superfícies podem desbotar, pois 100% da resistência à luz não pode ser alcançada. Não use este mobiliário ao ar livre. Não exponha este móvel a alta umidade e assegure uma temperatura estável. Objetos quentes não devem ser colocados diretamente em superfícies. Para limpar superfícies de madeira, metal e vidro, limpe com um pano húmido e seque imediatamente. Não use um agente de limpeza ou limpeza forte.

móveis estofados:

Para limpar as coberturas têxteis, basta limpá-las. Nunca use detergentes agressivos ou água sanitária. Para alimentos ou bebidas. Para reduzir o desgaste, use almofadas / almofadas regularmente, desde que sejam reversíveis.

CZ Gratulujeme k vašemu novému Jahnke nábytku!
Děkujeme za Váš nákup a doufáme, že jste se svou volbou spokojeni. Abychom si tento dobrý kus užili dlouho, žádáme Vás, abyste si před montáží pečlivě přečetli návod a pokyny k péči a dodržovali objednávku.

Péče o instrukce:

Důležité informace pro péči a používání nového nábytku:

Chraňte svůj nábytek před přímým slunečním zářením, extrémním světlem a teplem. Látky a povrchy mohou vyblednout, protože nelze dosáhnout 100% stálosti světla. Nepoužívejte tento nábytek venku. Nevystavujte tento nábytek vysoké vlhkosti a zajistěte stabilní teplotu. Horké předměty nesmí být umístěny přímo na povrchy. Pro čištění dřevěných, kovových a skleněných povrchů otřete vlhkým hadříkem a ihned osušte. Nepoužívejte silný čisticí nebo čistící prostředek.

Čalouněný nábytek:

K čištění textilních krytů je jednoduše vysajte. Nikdy nepoužívejte drsné čisticí prostředky nebo bělidla. Pro potraviny nebo nápoje. Aby se snížilo opotřebení, používejte pravidelně polštářky / polštáře, pokud jsou reverzibilní.



PL Gratulujemy zakupu nowych mebli Jahnke!
Dziękujemy za zakup i mamy nadzieję, że jesteś zadowolony z dokonanego wyboru. Aby cieszyć się tym dobrym kawałkiem przez długi czas, prosimy o uważne przeczytanie instrukcji i Instrukcji pielęgnacji przed montażem i przestrzeganie kolejności.

Obchodź instrukcjami:

Ważne informacje dotyczące pielęgnacji i użytkowania nowych mebli:
Chroń swoje meble przed bezpośrednim światłem słonecznym, ekstremalnym światłem i ciepłem. Substancje i powierzchnie mogą blaknąć, ponieważ nie można uzyskać 100% odporności na światło. Nie używaj tego mebla na zewnątrz. Nie wystawiaj tego urządzenia na działanie wysokiej wilgotności i upewnij się, że temperatura jest stabilna. Gorących przedmiotów nie wolno umieszczać bezpośrednio na powierzchniach. Aby wyczyścić powierzchnie drewniane, metalowe i szklane, wytrzyj je wilgotną szmatką i natychmiast wytrzyj do sucha. Nie używaj silnego środka czyszczącego lub czyszczącego.

Meble tapicerowane:

Aby wyczyścić pokrowce tekstylne, wystarczy je odkurzyć. Nigdy nie używaj ostrych detergentów lub wybielaczy. Na jedzenie lub napoje. Aby zmniejszyć zużycie, regularnie korzystaj z poduszek / poduszek, o ile są one odwracalne.

SK Gratulujeme k vášmu novému nábytku Jahnke!
Ďakujeme Vám za Váš nákup a dúfame, že ste s výberom spokojní. Aby ste si tento dobrý kus užili dlhú dobu, žiadame vás, aby ste si pred montážou pozorne prečítali pokyny a pokyny na starostlivosť a aby ste dodržali objednávku.

Starostlivosť o inštrukcie:

Dôležité informácie pre starostlivosť a používanie vášho nového nábytku:
Chránite svoj nábytok pred priamym slnečným svetlom, extrémnym svetlom a teplom. Látky a povrchy môžu vyblednúť, pretože nie je možné dosiahnuť 100% stálosť svetla. Nepoužívajte tento nábytok vonku. Nevystavujte tento nábytok vysokej vlhkosti a zabezpečte stabilnú teplotu. Horúce predmety nesmú byť umiestnené priamo na povrchy. Na čistenie povrchu dreva, kovu a skla, utrite vlhkou handričkou a okamžite osušte. Nepoužívajte silný čistiaci alebo čistiaci prostriedok. Čalúnený nábytok:

Na čistenie textilných krytov ich jednoducho vysajte. Nikdy nepoužívajte drsné čistiace prostriedky alebo bielidlá. Na jedlo alebo napoje. Aby sa znížilo opotrebovanie, pravidelne používajte vankúšiky / vankúše, pokiaľ sú reverzibilné.

HU Gratulálunk az új Jahnke bútorokhoz!
Köszönjük a vásárlást, és reméljük, hogy elégedettek vagyunk a választással. Annak érdekében, hogy hosszú ideig élvezhessük ezt a jó darabot, kérjük, gondosan olvassa el az utasításokat és az ápolási utasításokat a szerelés előtt, és tartsa be a rendet.

Kezelési útmutató:

Fontos információk az új bútorok gondozásáról és használatáról:
Védje bútorait a közvetlen napfénytől, a szélsőséges fénytől és a hőtől. Az anyagok és felületek elhalványulhatnak, mivel nem érhető el 100%-os könnyűség. Ne használja a bútorokat szabadban. Ne tegye ki a bútorokat magas páratartalomnak, és biztosítsa a stabil hőmérsékletet. A forró tárgyakat nem szabad közvetlenül a felületekre helyezni. A fa, fém és üvegfelületek tisztításához nedves ruhával törölje le és azonnal törölje le. Ne használjon erős tisztító- vagy tisztítószert.

Kárpitozott bútorok:

A textilburkolatok tisztításához egyszerűen törölje le őket. Soha ne használjon kemény vagy mosószeret. Ételt vagy italt. A kopás csökkentése érdekében rendszeresen használjon párnákat / párnákat, amennyiben azok visszafordíthatók.

RO Felicitări pentru noul dvs. mobilier Jahnke!
Vă mulțumim pentru achiziția dvs. și sperăm că sunteți mulțumit de alegerea dvs. Pentru a vă bucura mult timp de această piesă bună, vă rugăm să citiți cu atenție instrucțiunile și instrucțiunile de întreținere înainte de asamblare și să respectați ordinea.

Instrucțiunile de întreținere:

Informații importante pentru îngrijirea și utilizarea noului dvs. mobilier:
Protejați-vă mobilierul de lumina directă a soarelui, lumină extremă și căldură. Substanțele și suprafețele pot să se estompeze, deoarece nu se poate obține o rezistență la lumină de 100%. Nu folosiți acest mobilier în aer liber. Nu expuneți acest mobilier la umiditate ridicată și asigurați o temperatură stabilă. Elementele fierbinți nu trebuie plasate direct pe suprafețe. Pentru a curăța suprafețele din lemn, metal și sticlă, ștergeți-le cu o cârpă umeză și ștergeți-le imediat. Nu utilizați un agent de curățare sau de curățare puternic. Mobilier tapitat:
Pentru a curăța husă textilă, pur și simplu, îndepărtați-o. Nu folosiți niciodată detergenti dure sau înălbitori. Pentru alimente sau băuturi. Pentru a reduce uzura, utilizațiampoane / perne în mod regulat, atâta timp cât acestea sunt reversibile.

RU Поздравляем с новой мебелью от Jahnke!
Мы благодарим вас за покупку и надеемся, что вы удовлетворены своим выбором. Чтобы долго наслаждаться этой хорошей деталью, мы просим вас внимательно прочитать инструкции и инструкции по уходу перед сборкой и соблюдать порядок.

Инструкции по уходу:

Важная информация по уходу и использованию вашей новой мебели:
Защитите свою мебель от прямых солнечных лучей, экстремального света и тепла. Вещества и поверхности могут выцвести, так как 100% светостойкость не может быть достигнута. Не используйте эту мебель на открытом воздухе. Не подвергайте эту мебель высокой влажности и обеспечьте стабильную температуру. Горячие предметы нельзя размещать прямо на поверхности. Для очистки деревянных, металлических и стеклянных поверхностей протрите влажной тканью и немедленно вытрите насухо. Не используйте сильные чистящие средства или чистящие средства.

Мягкая мебель:

Для чистки текстильных чехлов просто пылесосите их. Никогда не используйте агрессивные моющие средства или отбеливатель. Для еды или напитков. Чтобы уменьшить износ, регулярно используйте прокладки / подушки, если они обратимы.

TR Yeni Jahnke mobilyalarınız için tebrikler!
Satın aldığınızı için teşekkür eder, seçiminizden memnun kalacağınızı umarız. Bu güzel parçanın uzun süre tadını çıkarmak için, montajdan önce talimatları ve bakım talimatlarını dikkatlice okumanızı ve sipariş izlemenizi rica ediyoruz.

Bakım talimatları:

Yeni mobilyanızın bakım ve kullanımıyla ilgili önemli bilgiler:
Mobilyalarınızı doğrudan güneş ışığından, aşırı ışık ve ısıdan koruyun. % 100 ışık haslığı sağlanamadığı için maddeler ve yüzeyler solabilir. Bu mobilyaları dış mekanlarda kullanmayın. Bu mobilyayı yüksek neme maruz bırakmayın ve sabit bir sıcaklık sağlayın. Sıcak nesnelere doğrudan yüzeylere yerleştirilmemelidir. Ahşap, metal ve cam yüzeyleri temizlemek için nemli bir bezle silin ve derhal kurulayın. Güçlü bir temizleme veya temizleme maddesi kullanmayın.

Döşemeli mobilya:

Tekstil kapaklarını temizlemek için basitçe süpürerek temizleyin. Asla sert deterjan veya çamaşır suyu kullanmayın. Yiyecek ve içecek için. Aşınmayı azaltmak için, geri dönüşümlü oldukları sürece düzenli olarak ped / yastık kullanın.



1

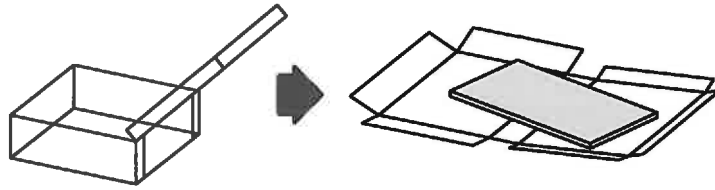

2

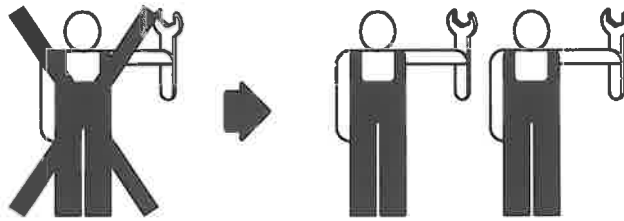

3

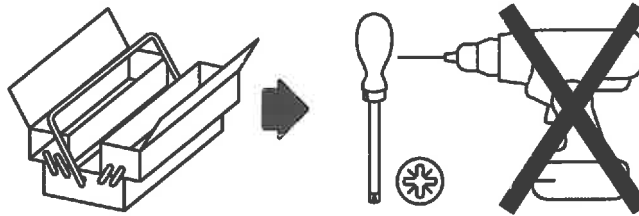

4

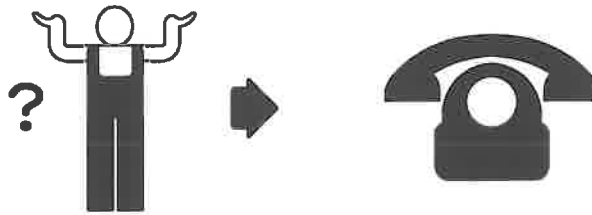

5

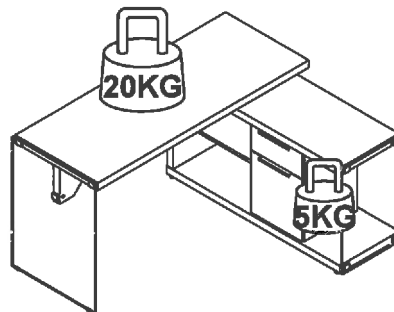

6

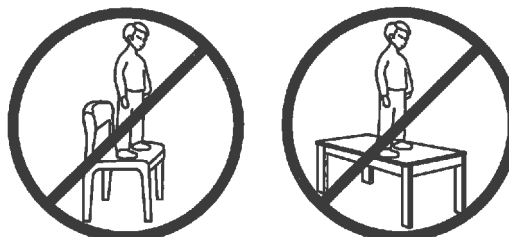

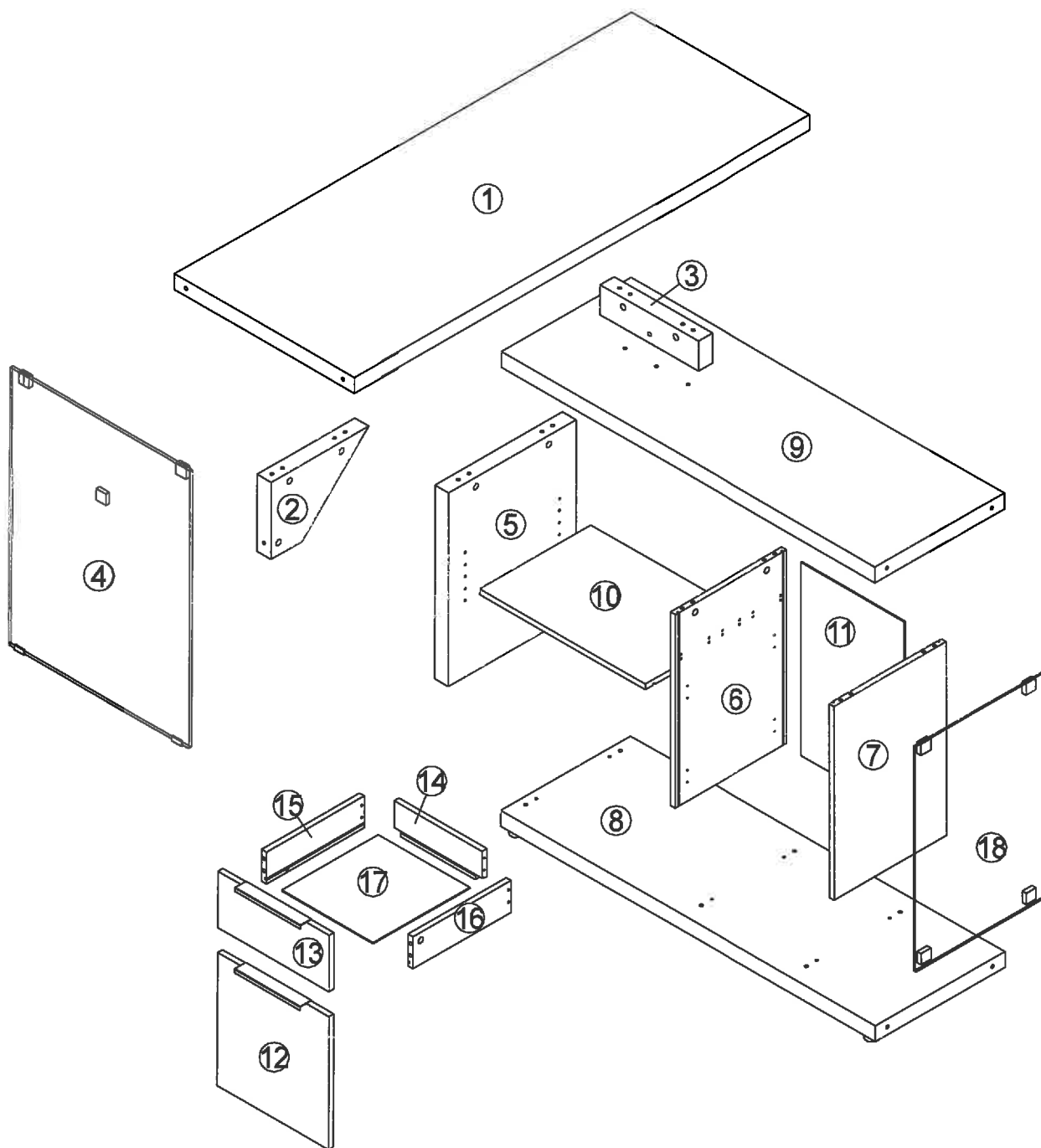

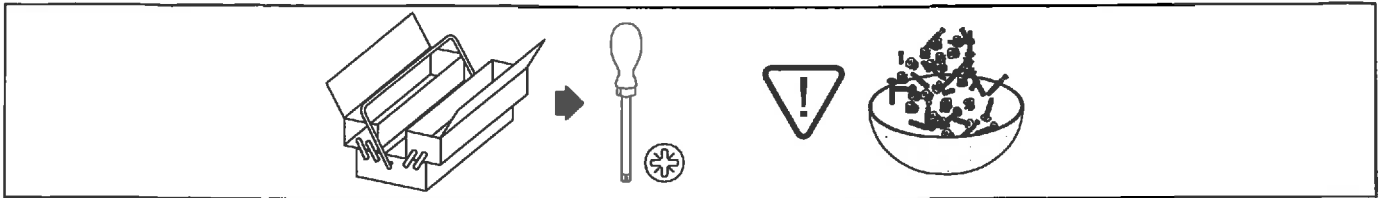

A	B	C	D	E	F
LEIM / GLUE	Ø 8x30mm	Ø 6x35mm	Ø 15mm	55mm	15mm
1x	20x	12x	19x	6x	4x



G	H	I	J	K	L
Ø 4.2x35mm		Ø 35.5mm	Ø 9.5x13mm	M6x73mm	M4
4x	2x	5x	1x	1x	1x

M	N	O	P	Q	R
M6x32.5mm	200mm	Ø 4x15mm	300mm	Ø 6x13mm	
7x	2x	4x	1 SET	12x	2x

S	T	U	V
Ø 4x15mm	Ø 20mm		Ø 3x19mm
8x		4x	4x

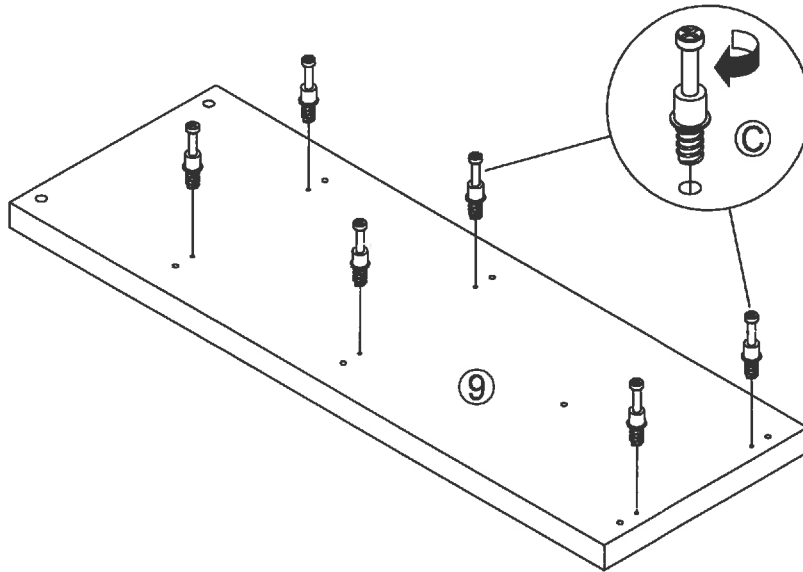
<h1>1</h1>	<p>C</p>  <p>6x</p>		
------------	---	---	---

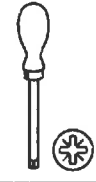
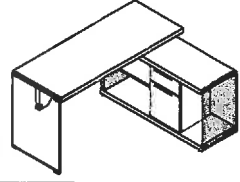

<h1>2</h1>	<p>A</p>  <p>LEIM/GLUE</p>	<p>B</p>  <p>4x</p>	<p>M</p>  <p>4x</p>		
------------	--	---	---	---	---

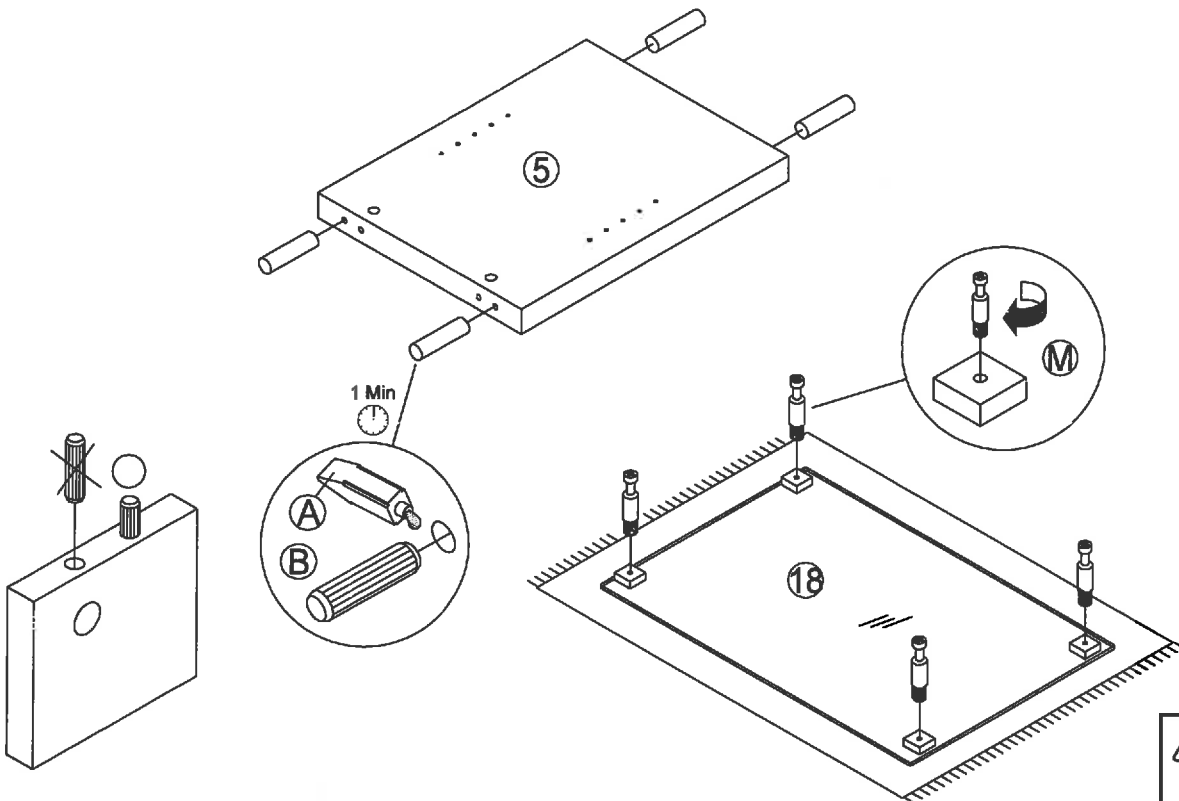

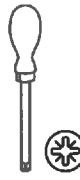
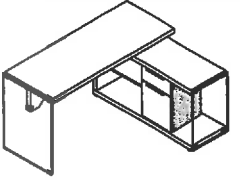



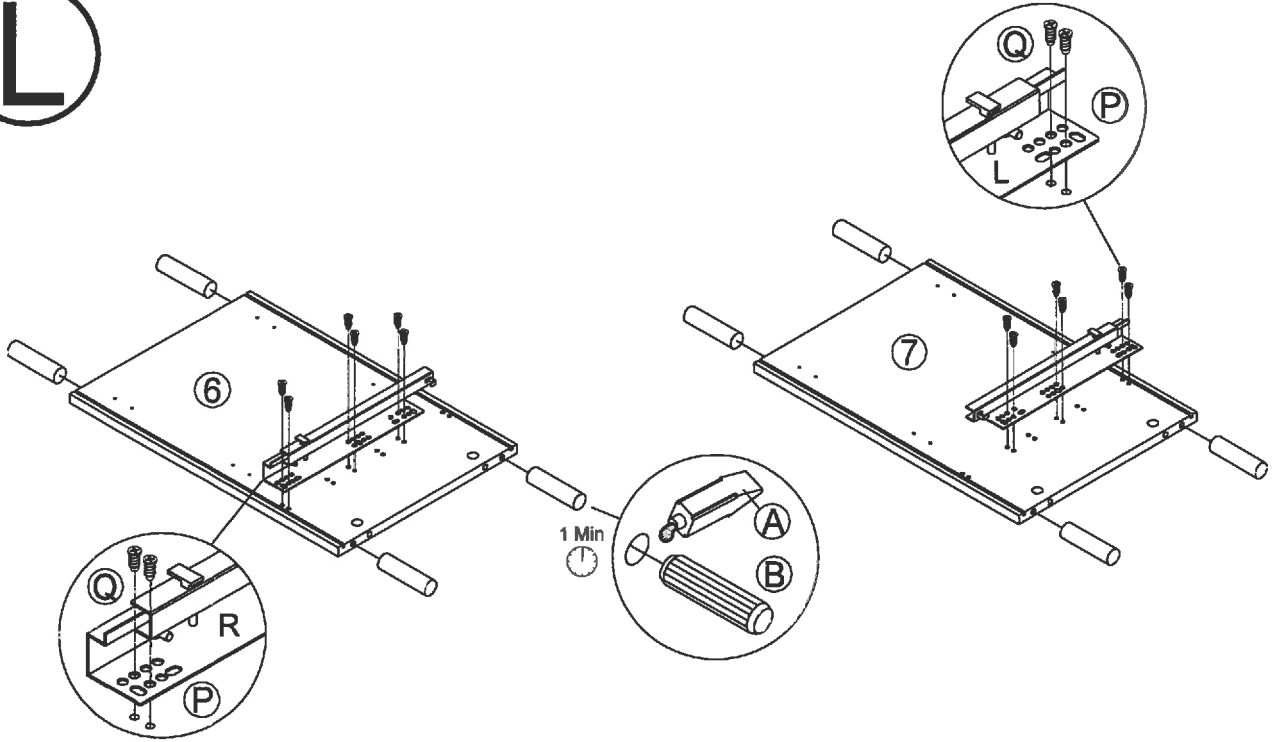

3	A	B	P	Q	 
	LEIM/GLUE	8x	1 SET	12x	

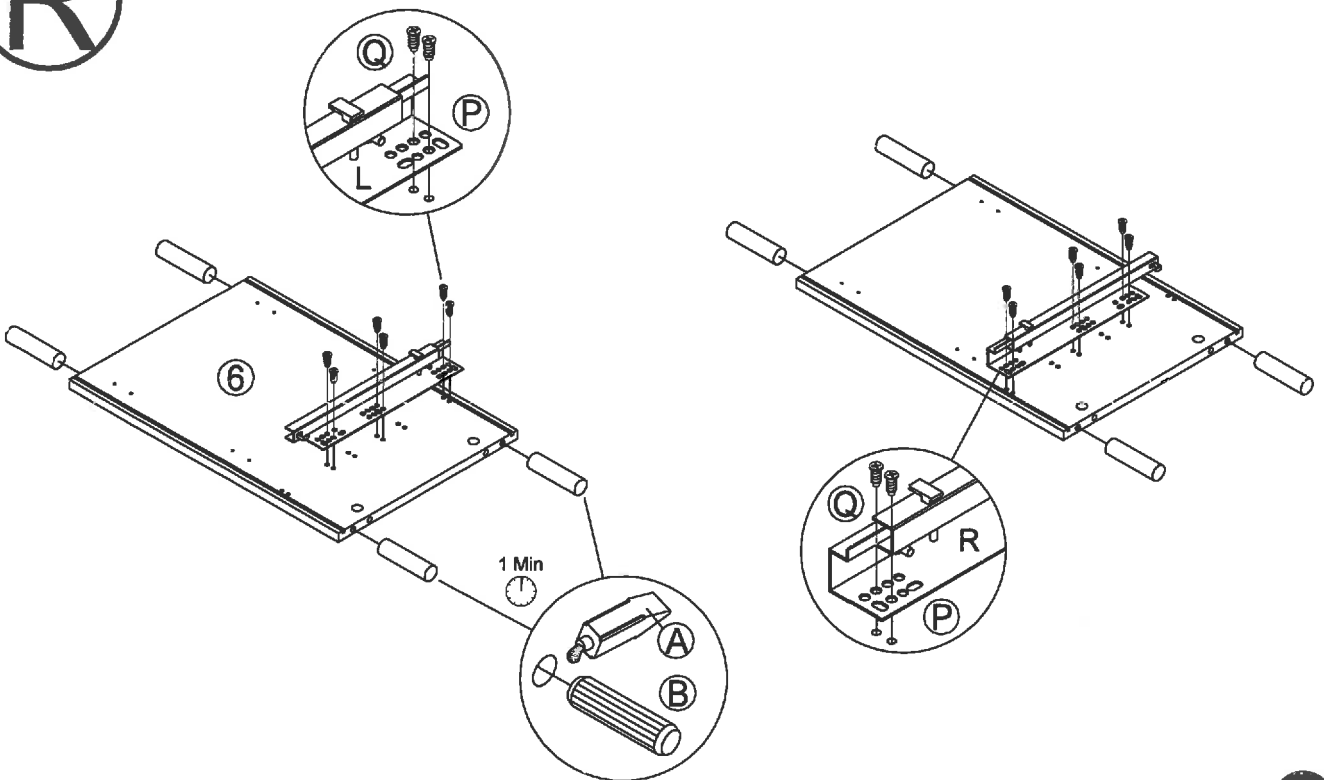
L



R





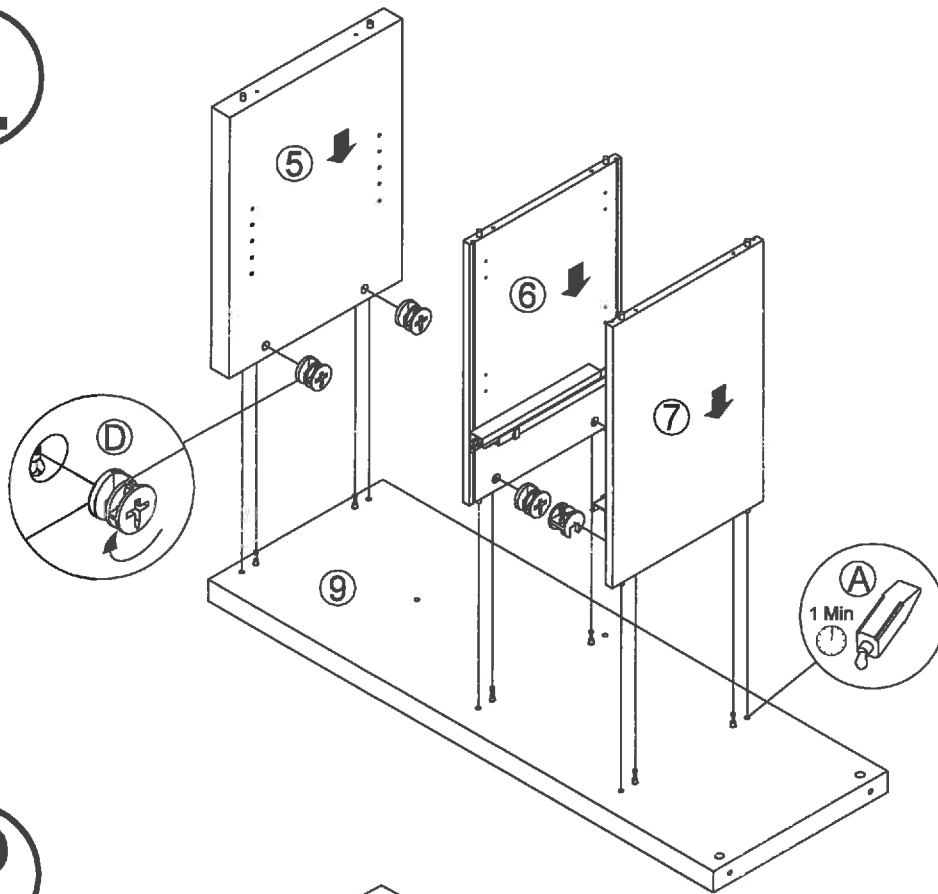

4	A	D	T		
					
	LEIM/GLUE	6x	6x		

L

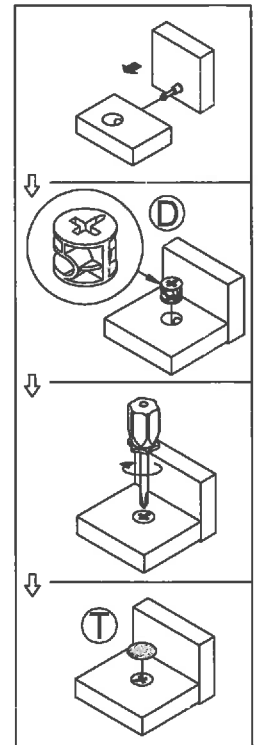
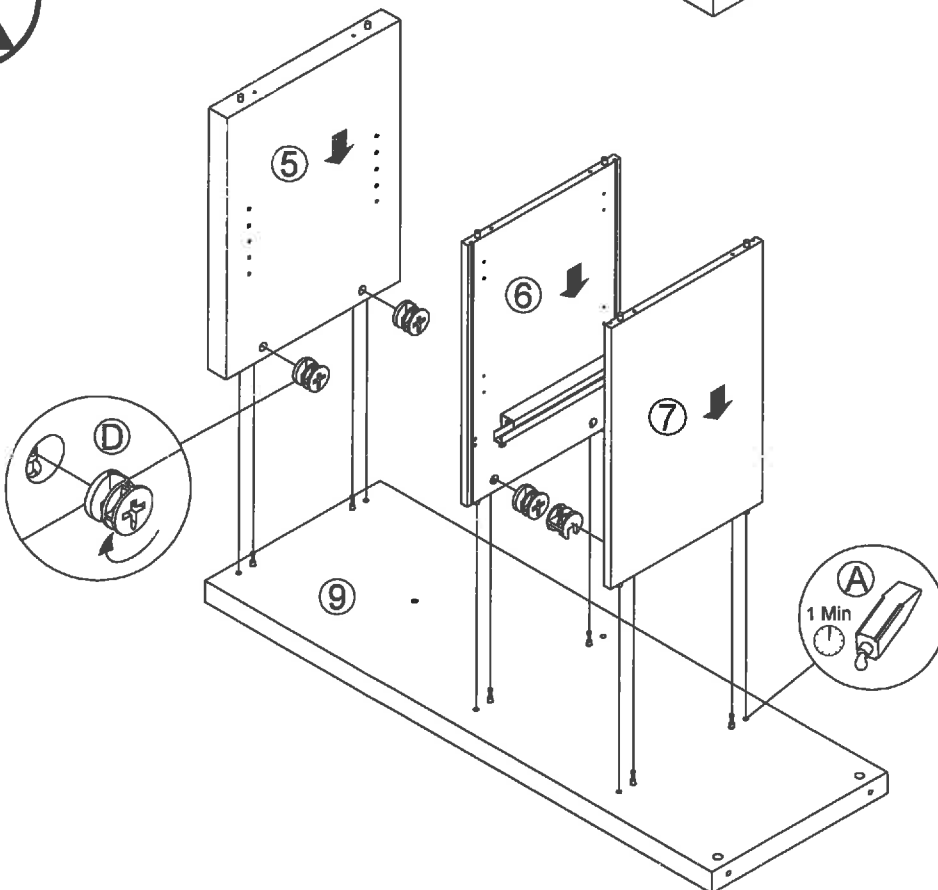

R



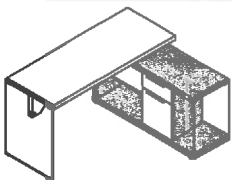

<h1>5</h1>	<p>A</p>  <p>LEIM/GLUE</p>	<p>E</p>  <p>6x</p>	 	
------------	---	--	---	---

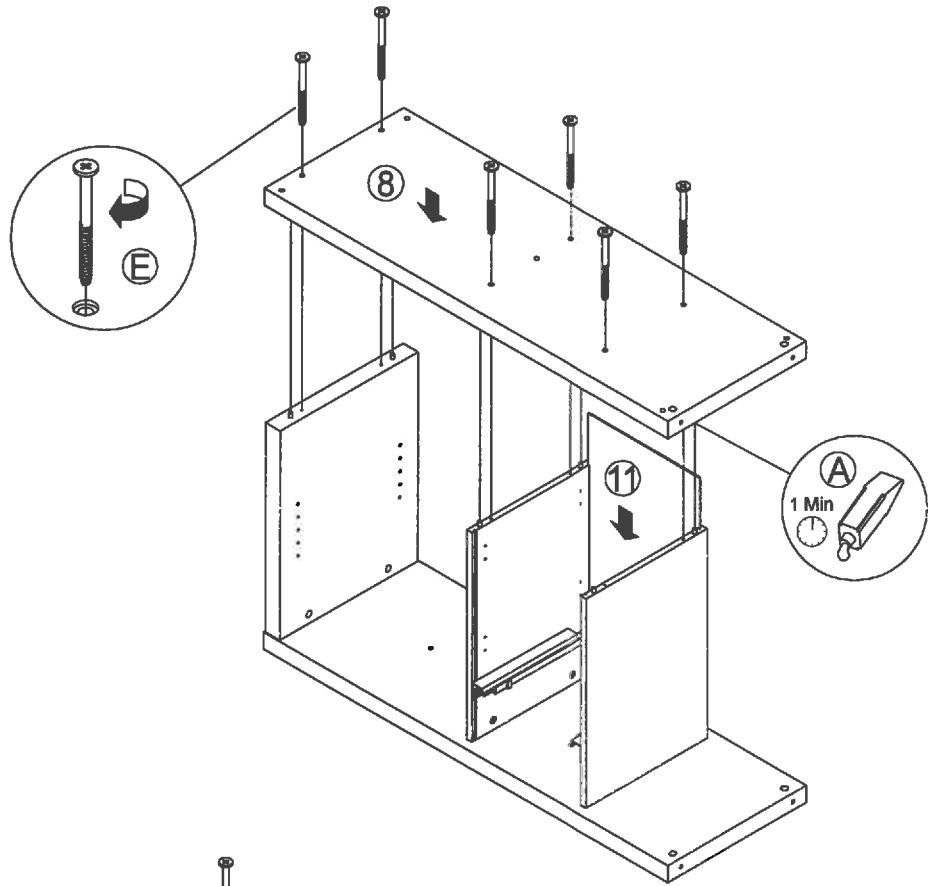
L

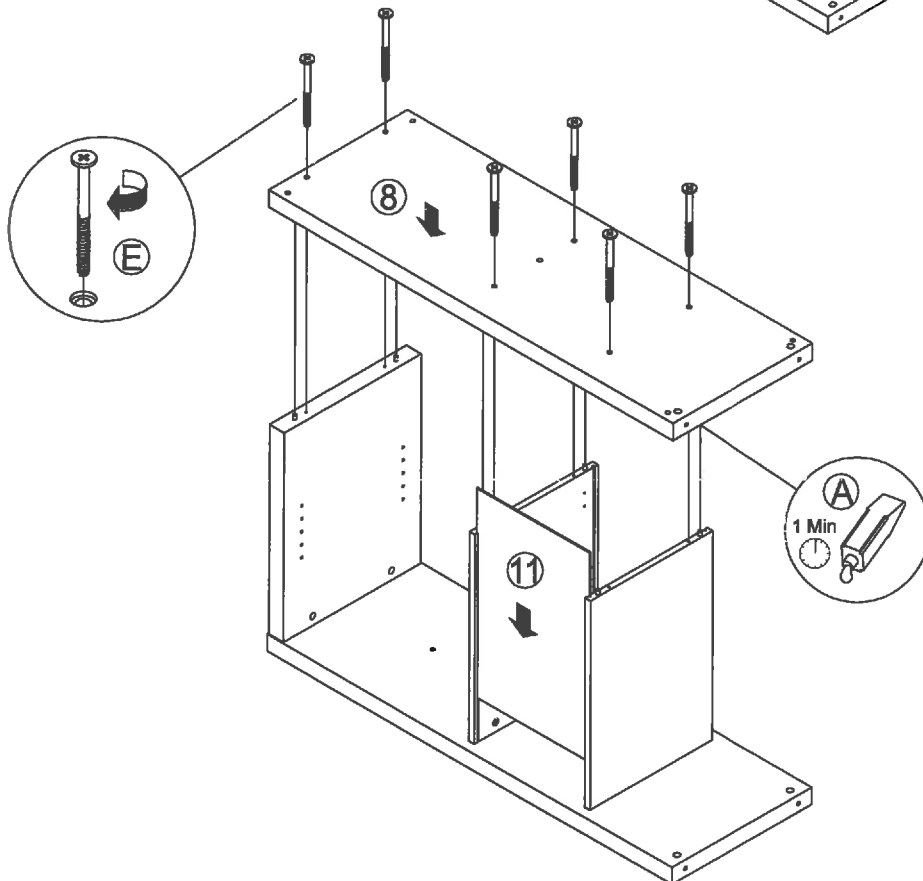

R



<h1>6</h1>	D	T	 
	 4x	 4x	

L

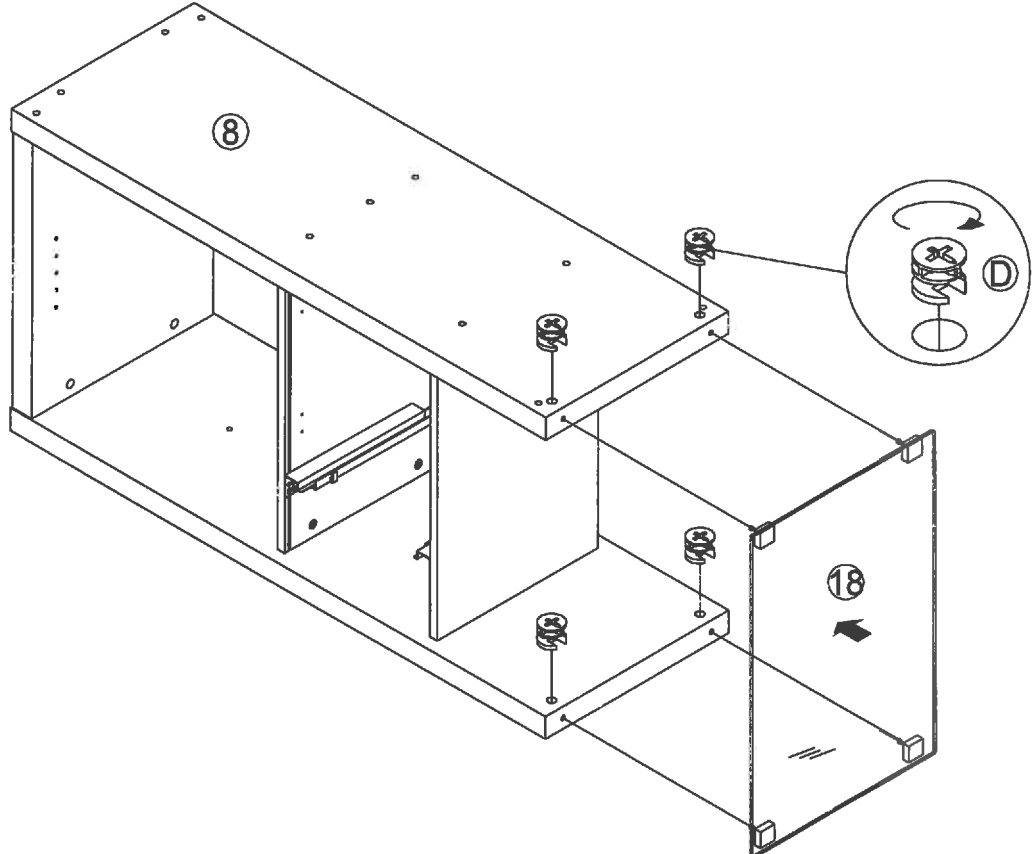

R

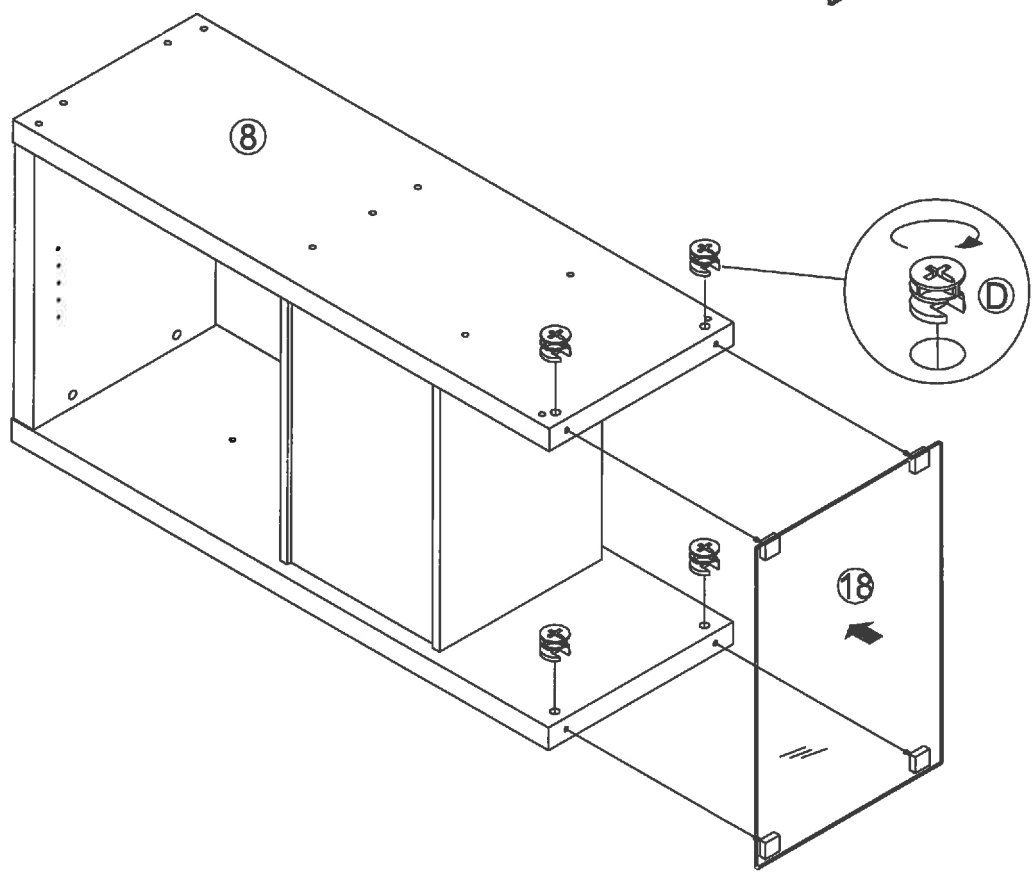

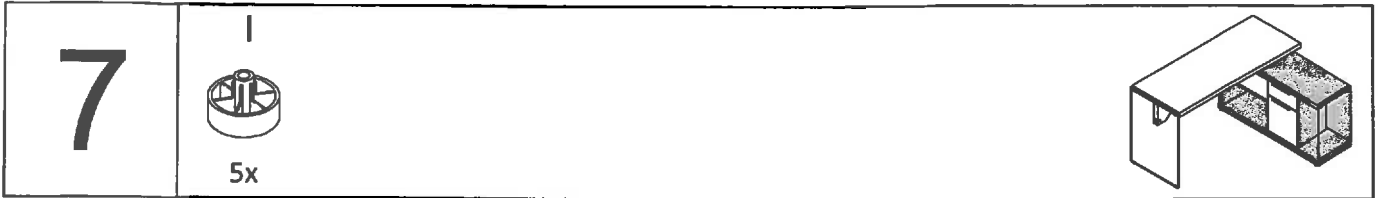



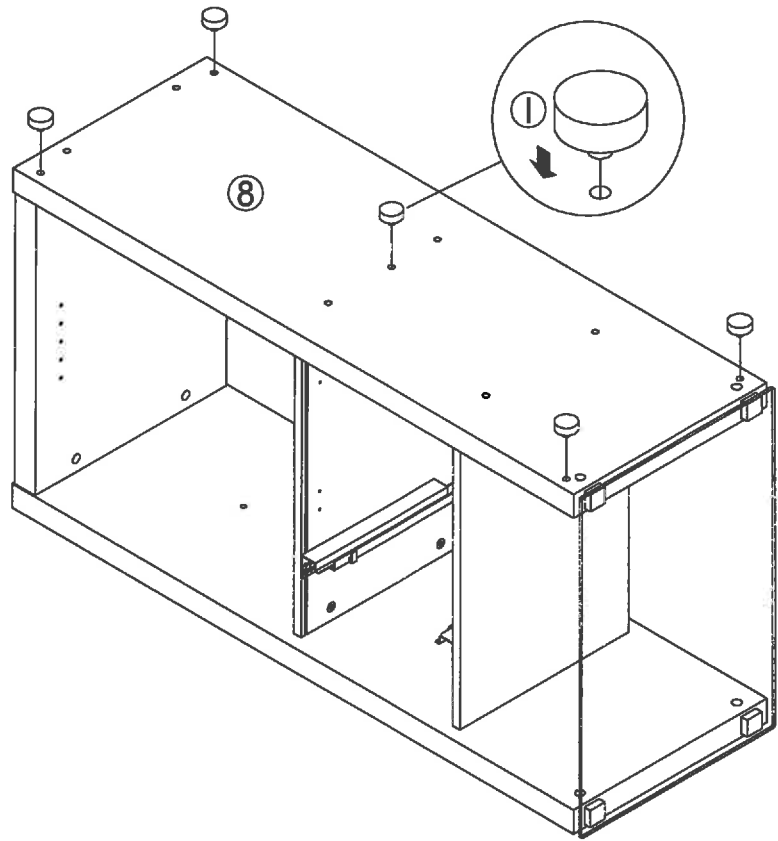
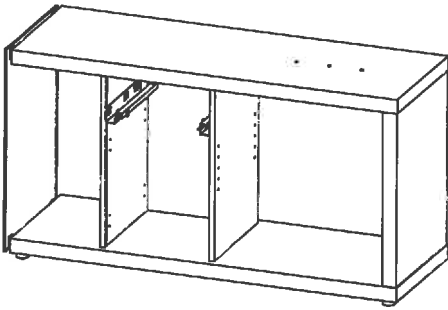



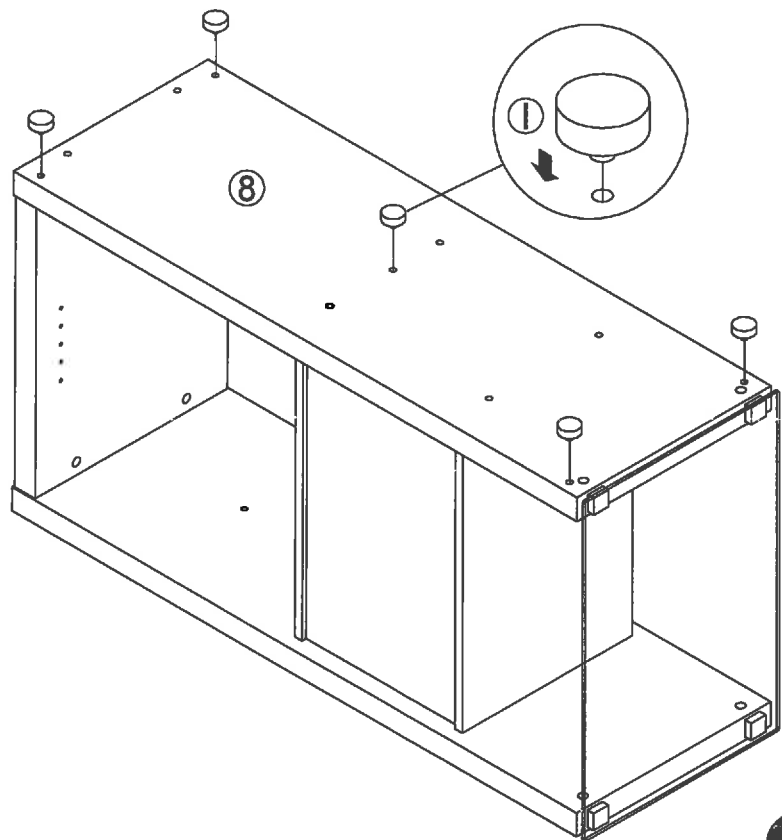
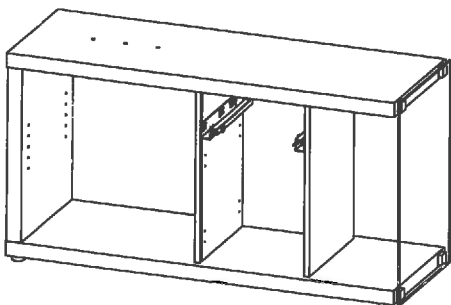

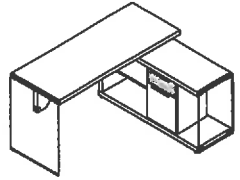

L







R

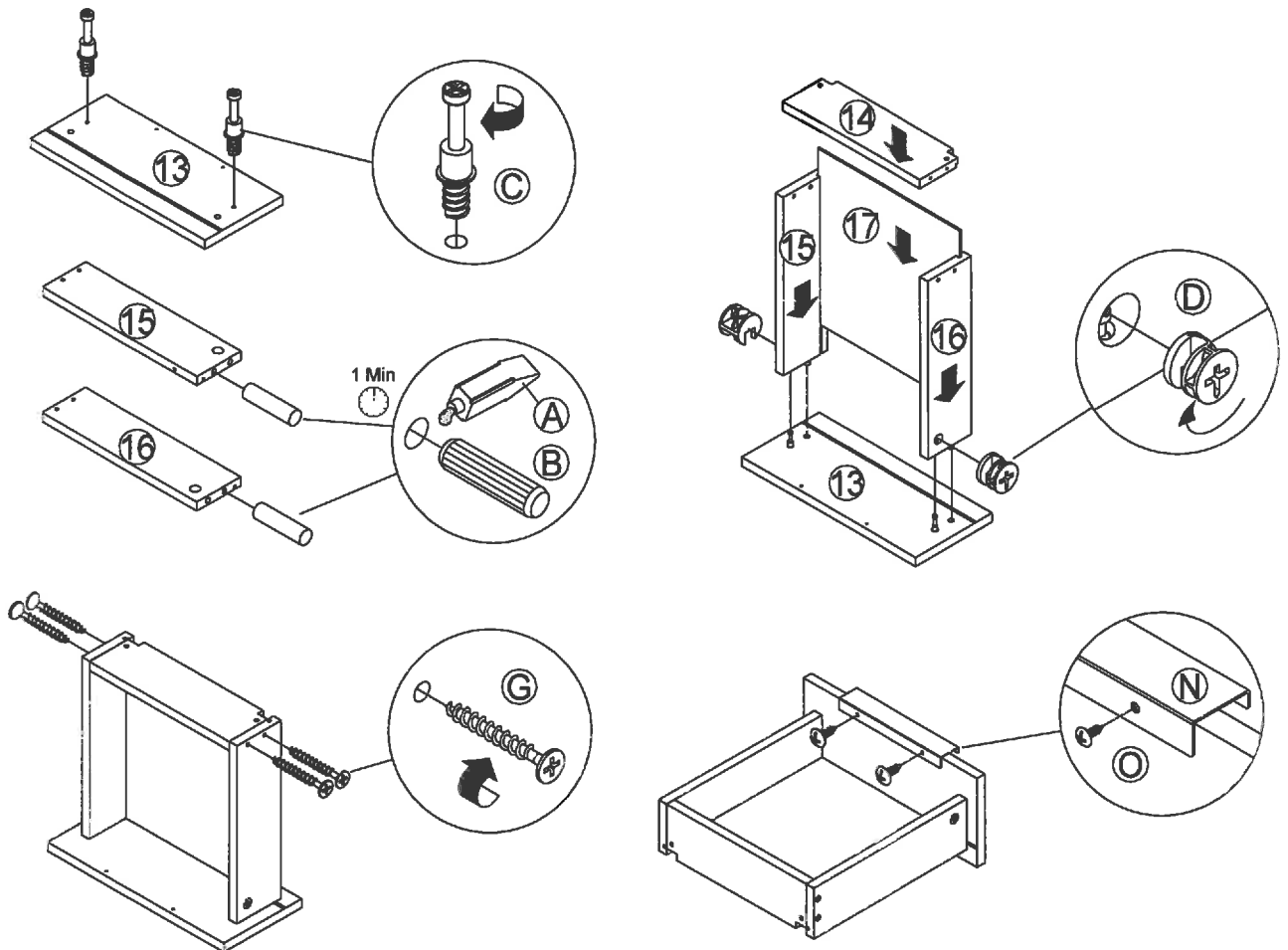

8	A	B	C	D	T	G	N	O	 	
	 LEIM/GLUE	 2x	 2x	 2x	 2x	 4x	 1x	 2x		

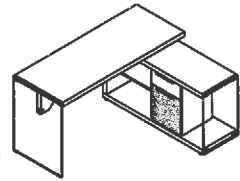

9	R	S	 	
	 2x	 4x		

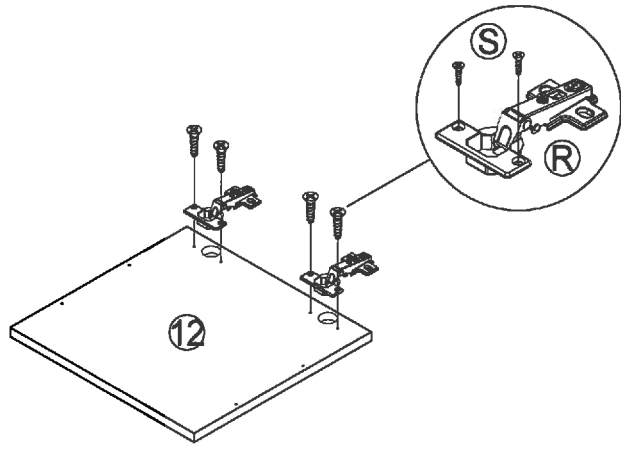

10 **F**

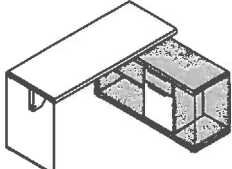
4x



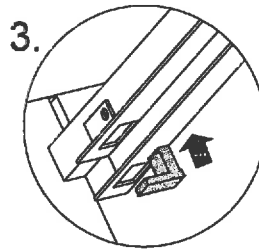
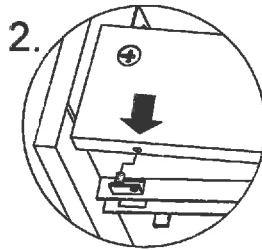
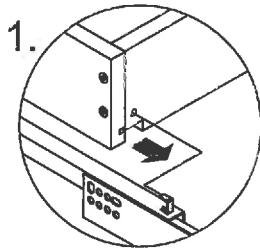
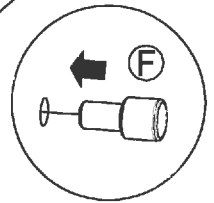
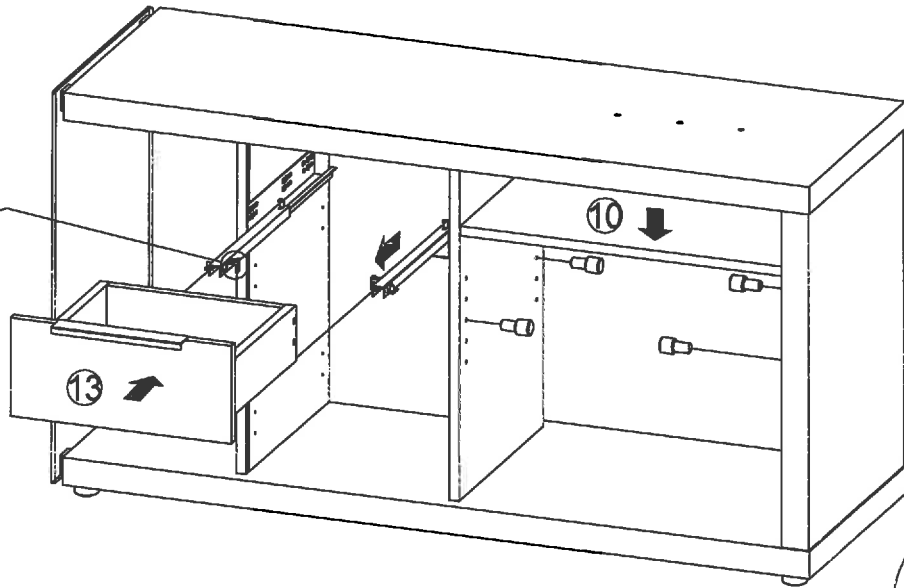
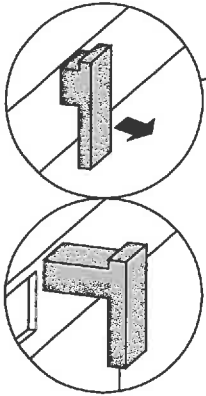

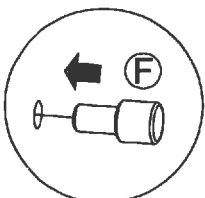
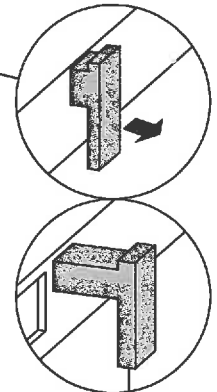
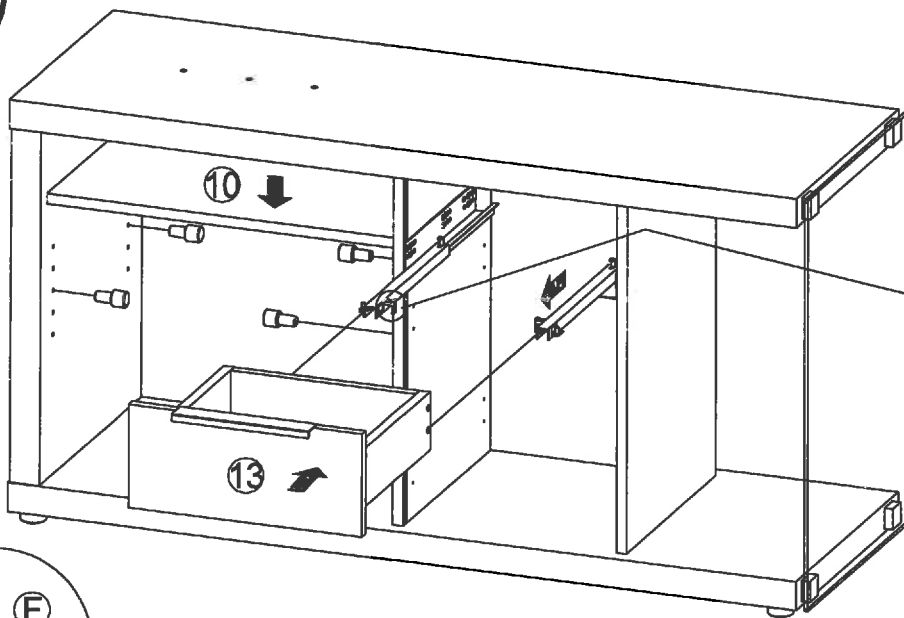

L

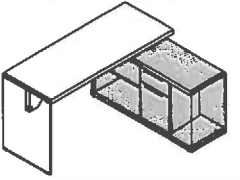

R



11	N	O	S		
					
	1x	2x	4x		

L

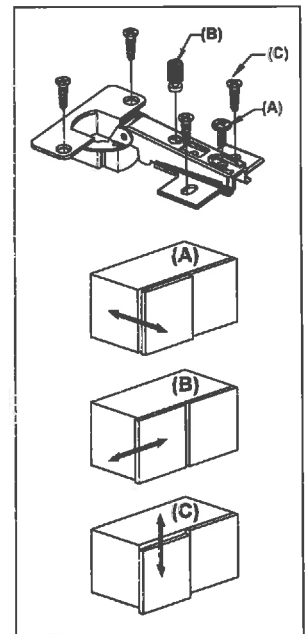
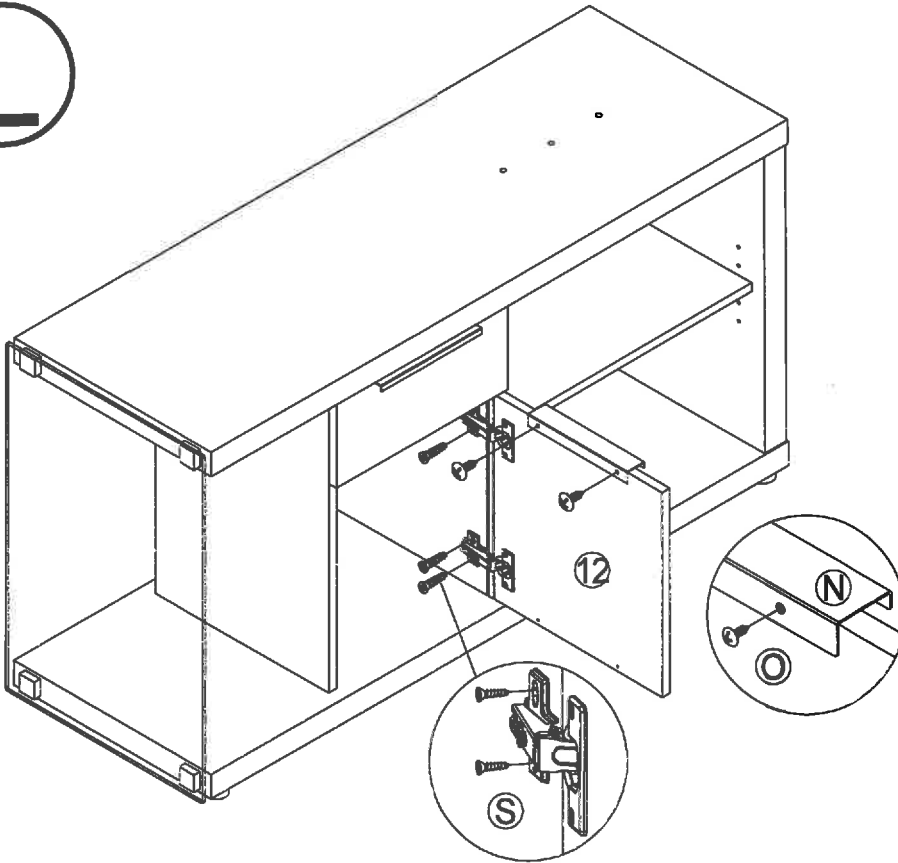

R

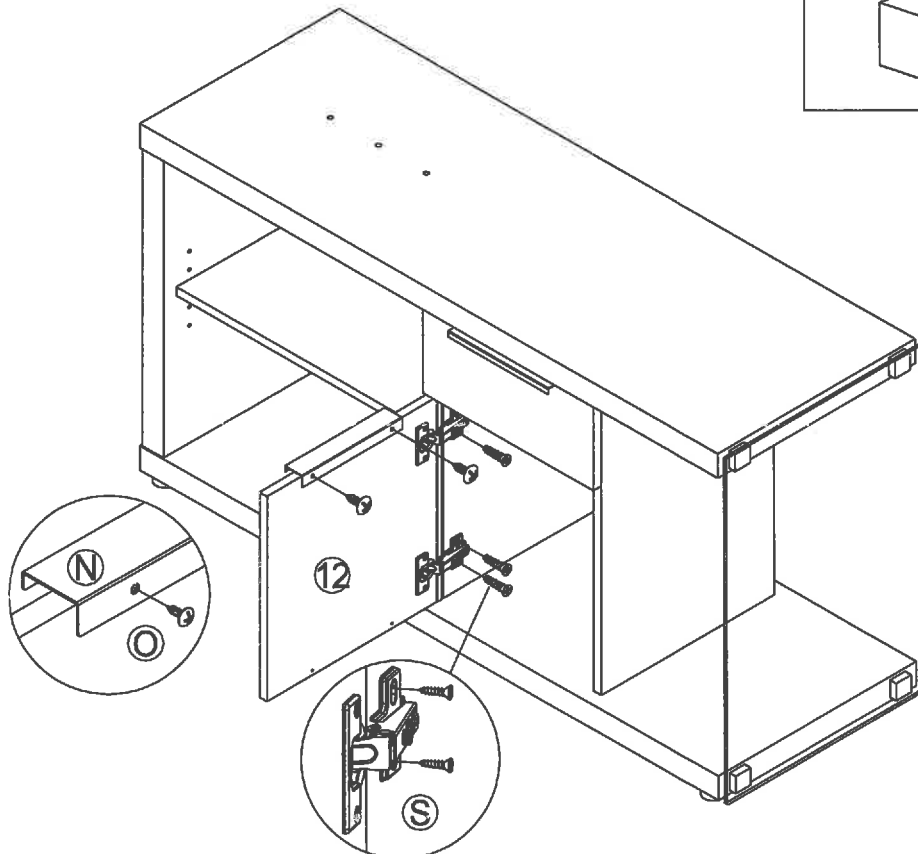

12

U 4x

V 4x



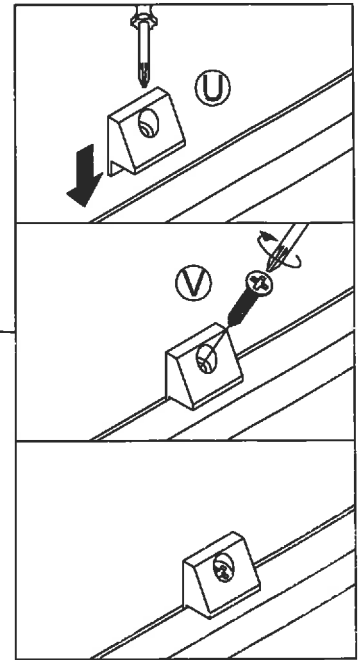
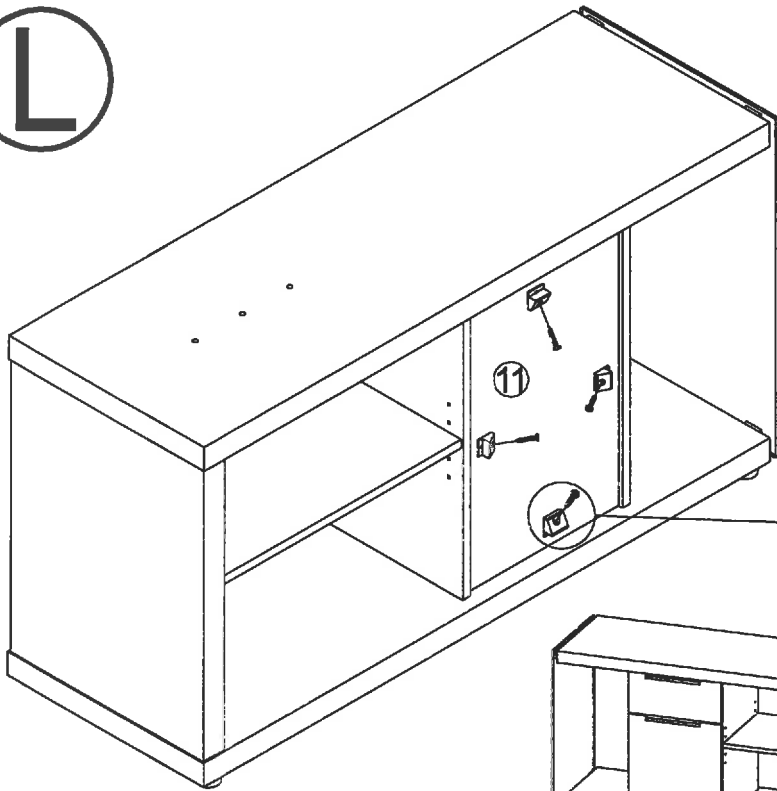

L

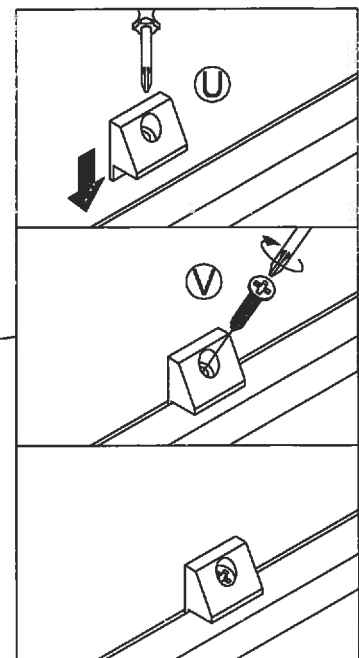
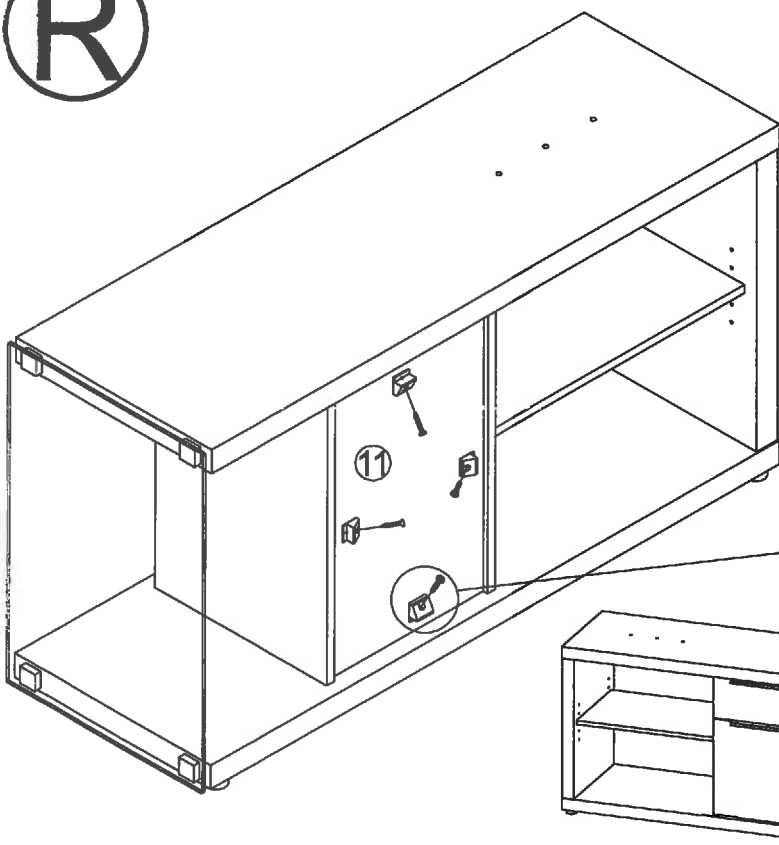

R



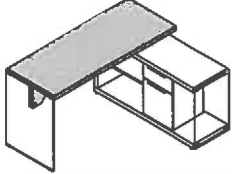

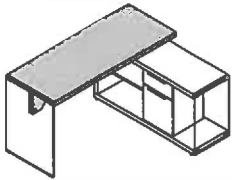

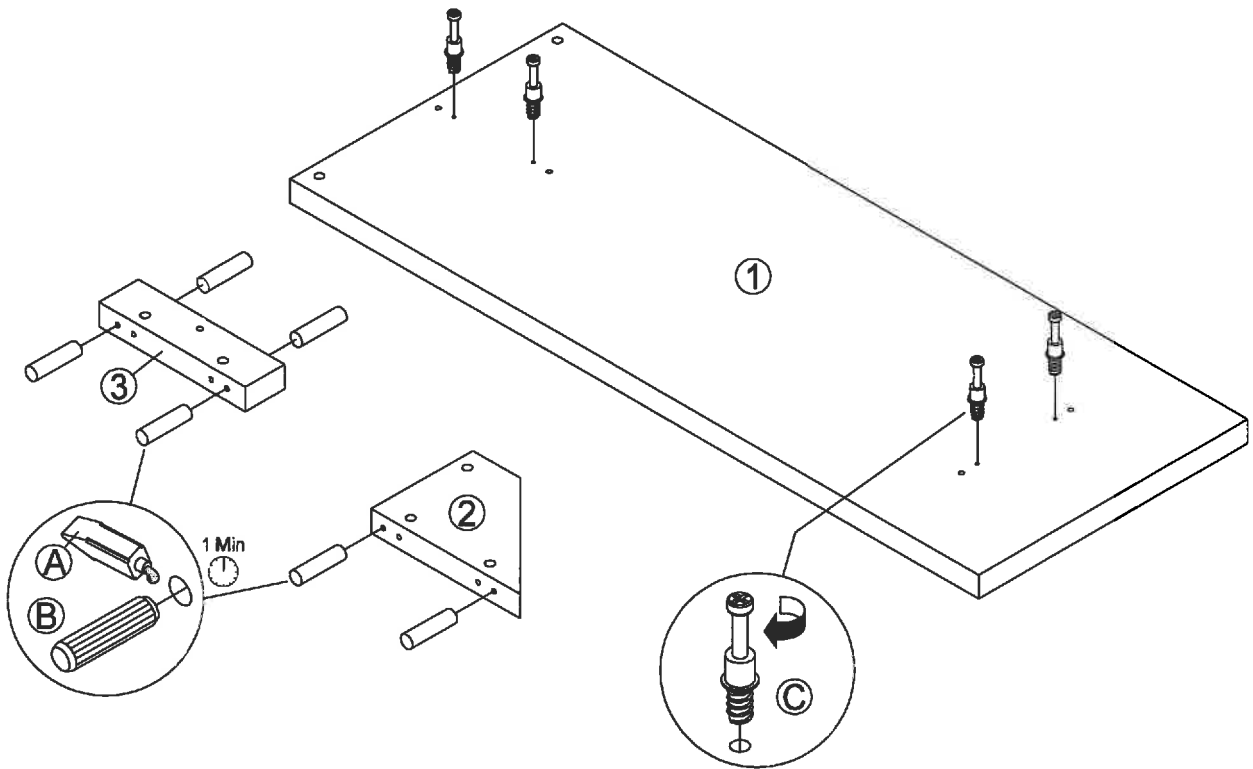
13



A	B	C	
			
LEIM/GLUE	6x	4x	

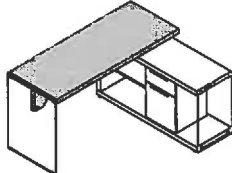

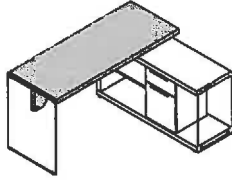

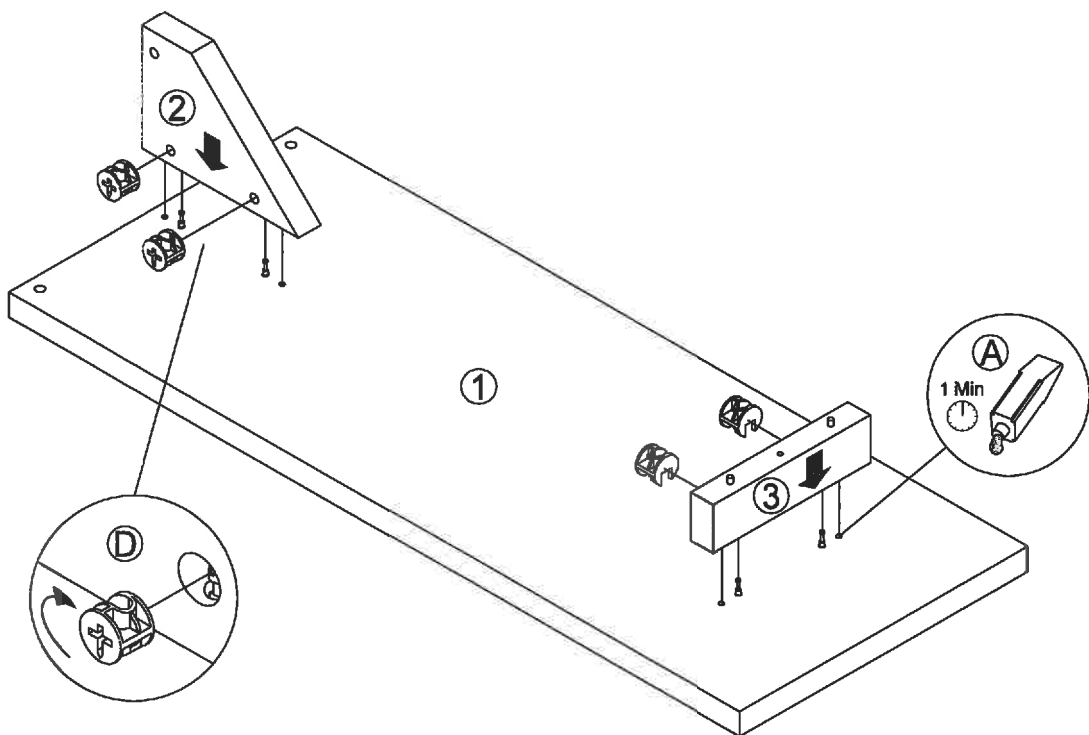
14

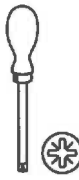
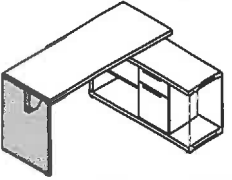
A	D	T	
			
LEIM/GLUE	4x	4x	

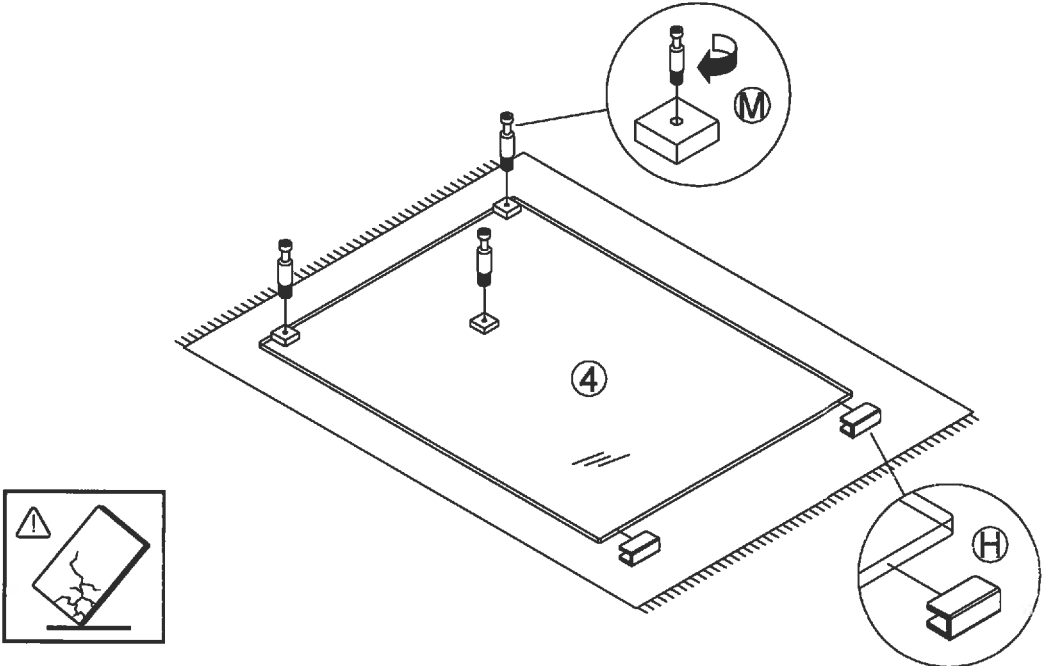

<h1>15</h1>	M	H	 
	 3x	 2x	

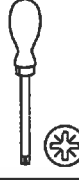
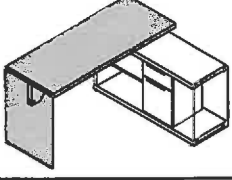

<h1>16</h1>	D	T	 
	 3x	 3x	

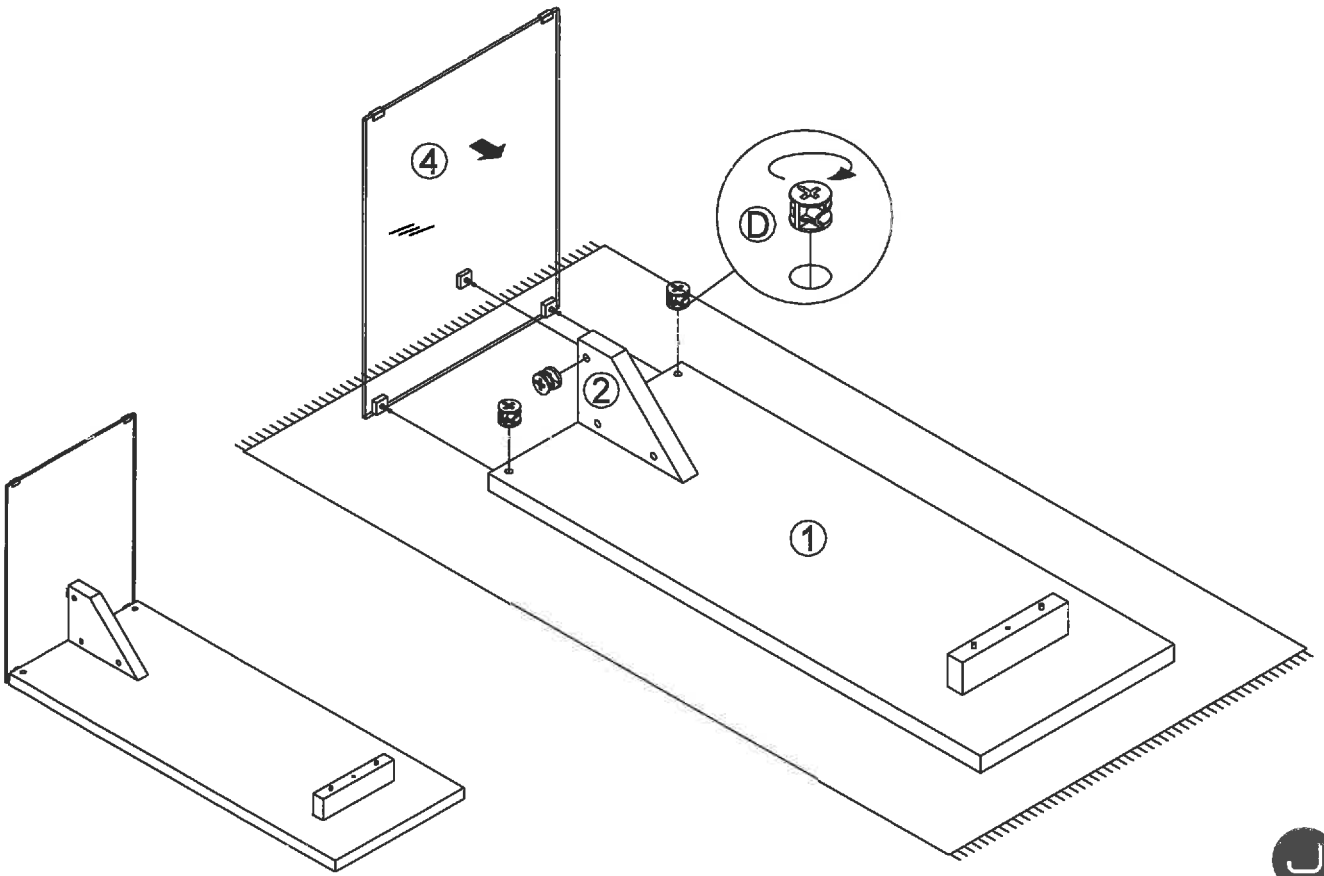

17	A	J	K	L	T	M4	
	LEIM/GLUE	1x	1x	1x	1x		

L

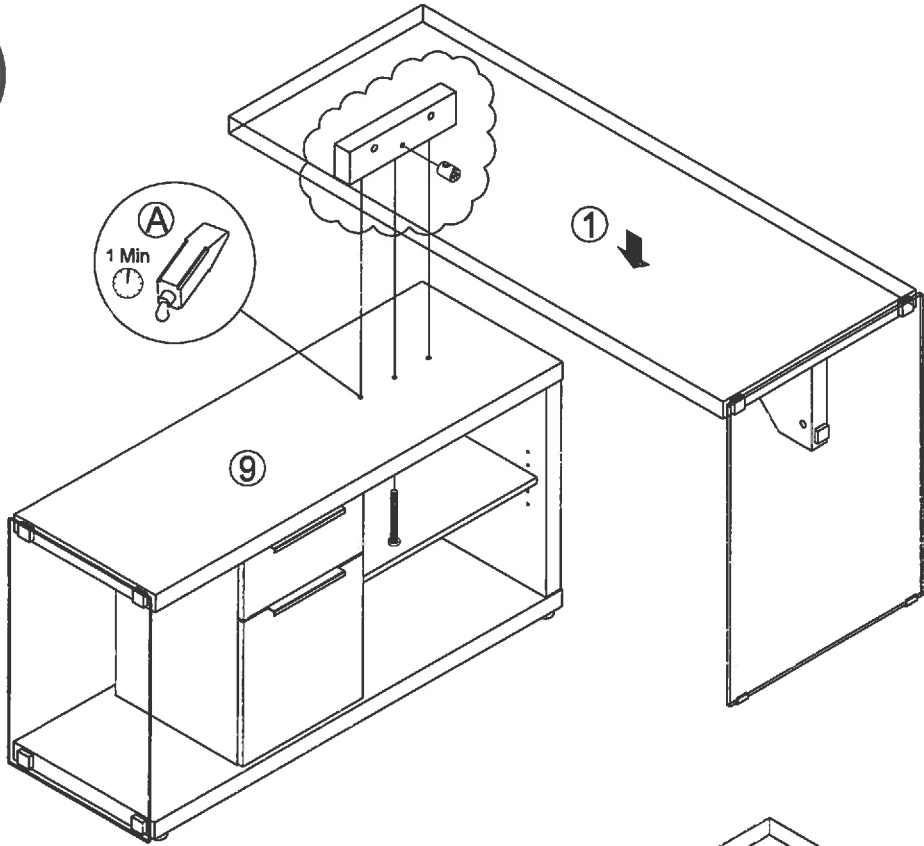

R

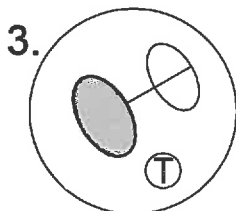
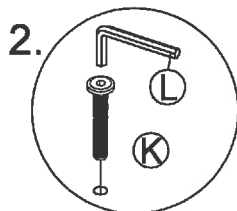
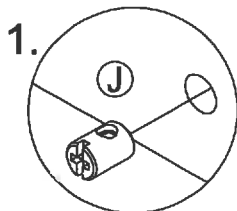
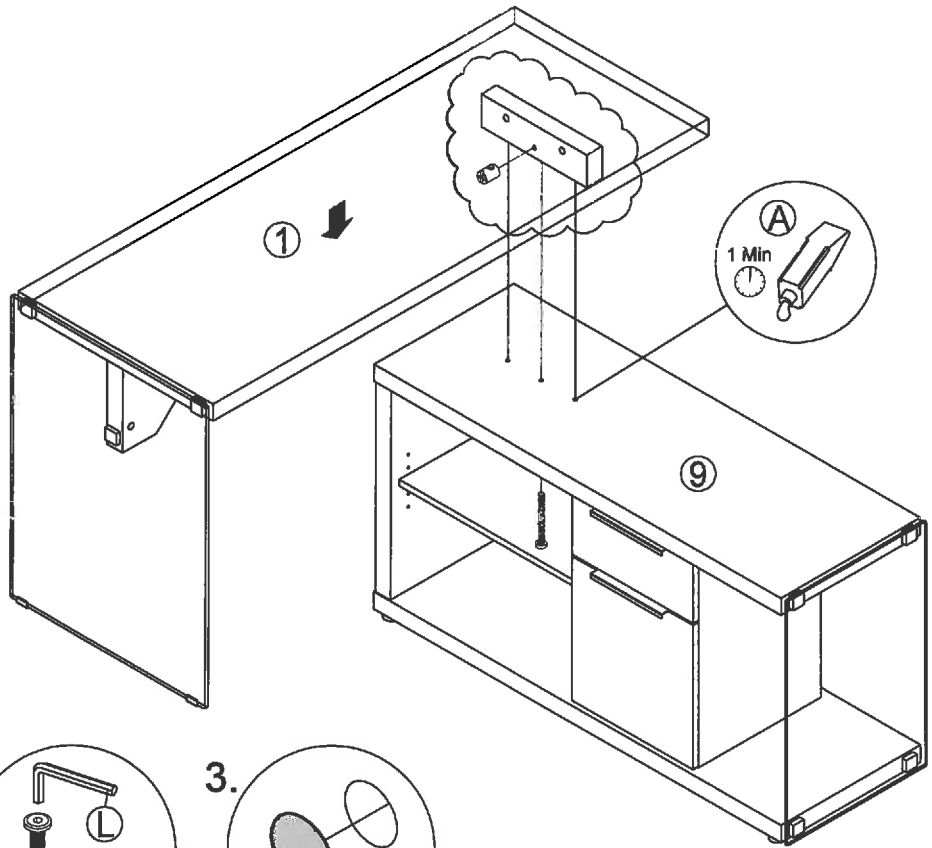

**Jahnke Vertriebs GmbH
Von-Bonsart-Straße 11
22885 Barsbüttel, Deutschland**