

44631013

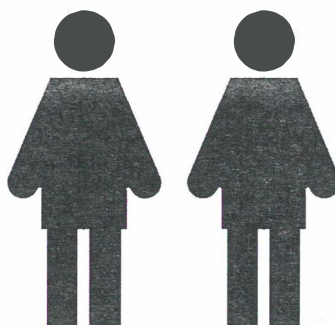
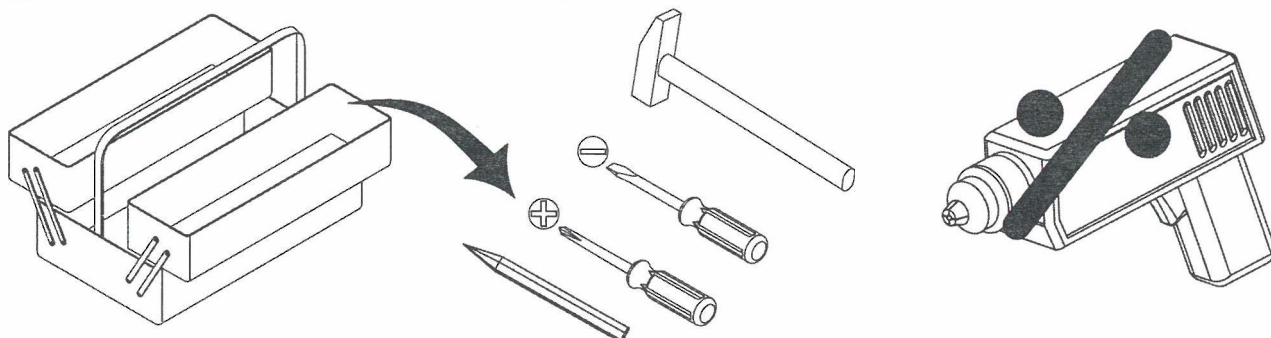
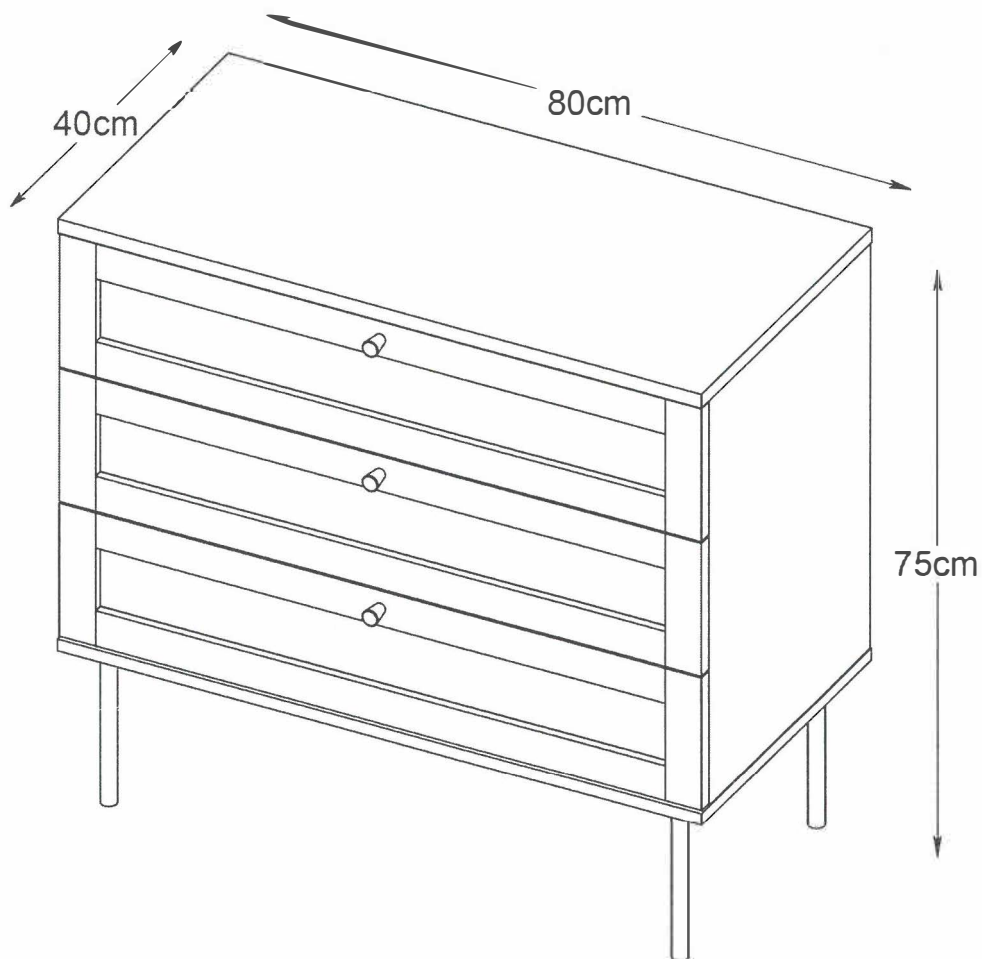

WICHTIG - FÜR SPÄTERE VERWENDUNG
AUFBEWAHREN - SORGFÄLTIG LESEN

AVIS - Ces instructions doivent être sauvegardées
Pour utilisation future - Les instructions doivent
être suivies

IMPORTANTE, conservar estas instrucciones
para futuro uso. Siga estas instrucciones atentamente

VIGTIGT - Samlevejledningen skal opbevares
i arkiv til senere brug - Skal gennemlæses nøje

NOTICE - These instructions must be saved
for future use - Instructions must be followed

TEILCHECKLISTE
 LISTE DE CONTROLE
 LISTADO DE CONTROL
 TJEKLISTE
 CHECK LIST



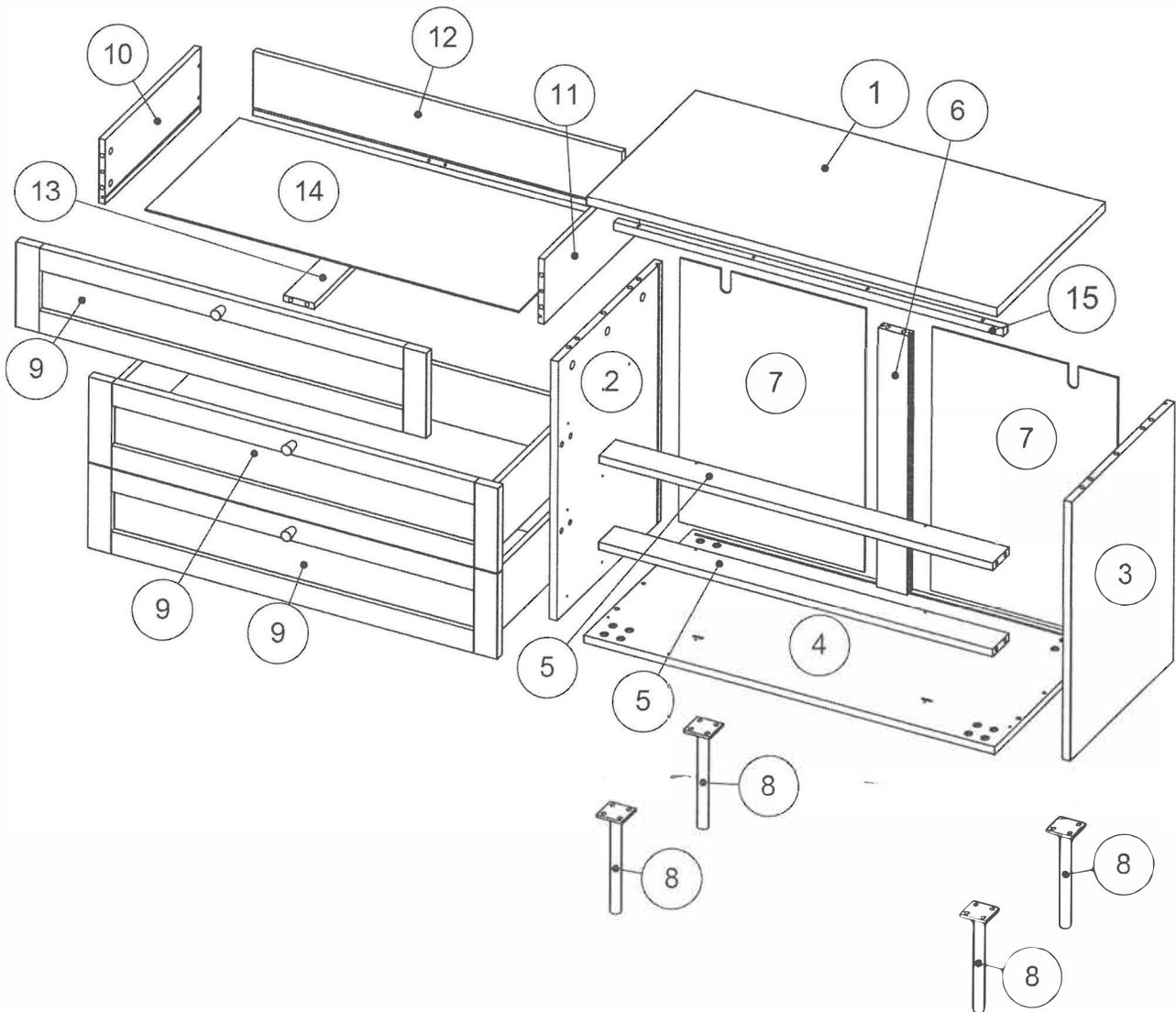









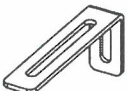





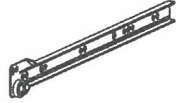
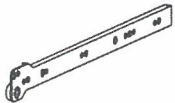

Réf./No.	Réf./Art.	Qty./Stck./Quantité	Size / Maß / Dimension (mm)	Qty./Stck./Quantité	✓
1	32828800	1	800x400x18		
2	32828900	1	519x379x15		
3	32829000	1	519x379x15		
4	32829100	1	800x400x15		
5	32829200	2	768x60x15		
6	32829300	1	519x60x18		
7	32829400	2	528x363x3		
8	227609	4	50x50x200		
9	32829511	3	798x170x18		
10	32829600	3	350x130x12		
11	32829700	3	350x130x12		
12	32829800	3	719x128x12		
13	32829900	3	336x60x12		
14	32832000	3	729x346x3		
15	228321	1	760x16x16		



TEILCHECKLISTE - LISTE DE CONTROLE - LISTADO DE CONTROL - TJEKLISTE - CHECK LIST

Réf./No.	Réf./Art.	Qty./Stck./Quantité	✓
A	228323	8	
B	228323	18	
C	228323	18	
D	228323	2	
E	228323	10	
F	228323	14	
H	228323	16	
J	228323	2	
M	228232	3	
N	228232	3	
Q	228323	52	
R	228323	6	

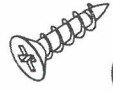
Réf./No.	Réf./Art.	Qty./Stck./Quantité	✓
T	228322	3	
U	228322	3	
V	228323	1	
W	228323	6	
X	228323	18	
Y	228323	18	
Z	228323	6	
AA	228322	3	
AB	228322	3	
AC	228323	18	
AG	228323	40	
AR	228323	16	

8 - A  ∅8x30mm	18 - B  ∅6x34mm	18 - C  ∅15x12mm	2 - D  72x25x15mm	10 - E  ∅3.5x14mm	14 - F 
16 - H  M6x13mm	2 - J  4mm	3 - M  20mm	3 - N  M4x20mm	52 - Q  ∅20mm	6 - R  ∅5x38mm
3 - T  350mm	3 - U  350mm	1 - V  3mm	6 - W  55mm	18 - X  ∅6x20mm	18 - Y  ∅12x9mm
6 - Z  ∅6x30mm	3 - AA  350mm	3 - AB  350mm	18 - AC  ∅4x30mm	40 - AG  ∅3.5x14mm	16 - AR  M6x13mm

Geehrter Kunde.
Hier haben Sie die Möglichkeit die mitgelieferten
Schrauben nachzumessen.

Cher Client.
La règle ci jointe vous permet de mesurer la visserie.

Estimado cliente.
aquí podrá medir la tornillería adjunta.

Kære kunde.
Her har De muligheden for at måle medsendte beslag.

Dear Customer.
Below you have the opportunity to measure the
Enclosed Hardware.

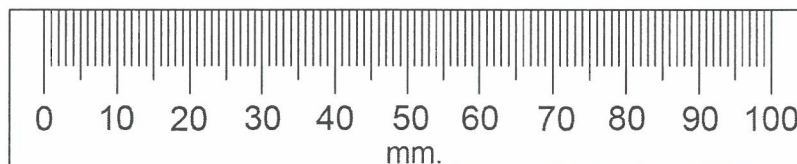

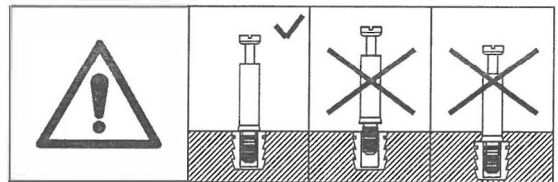
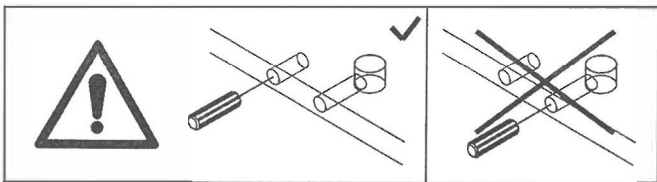
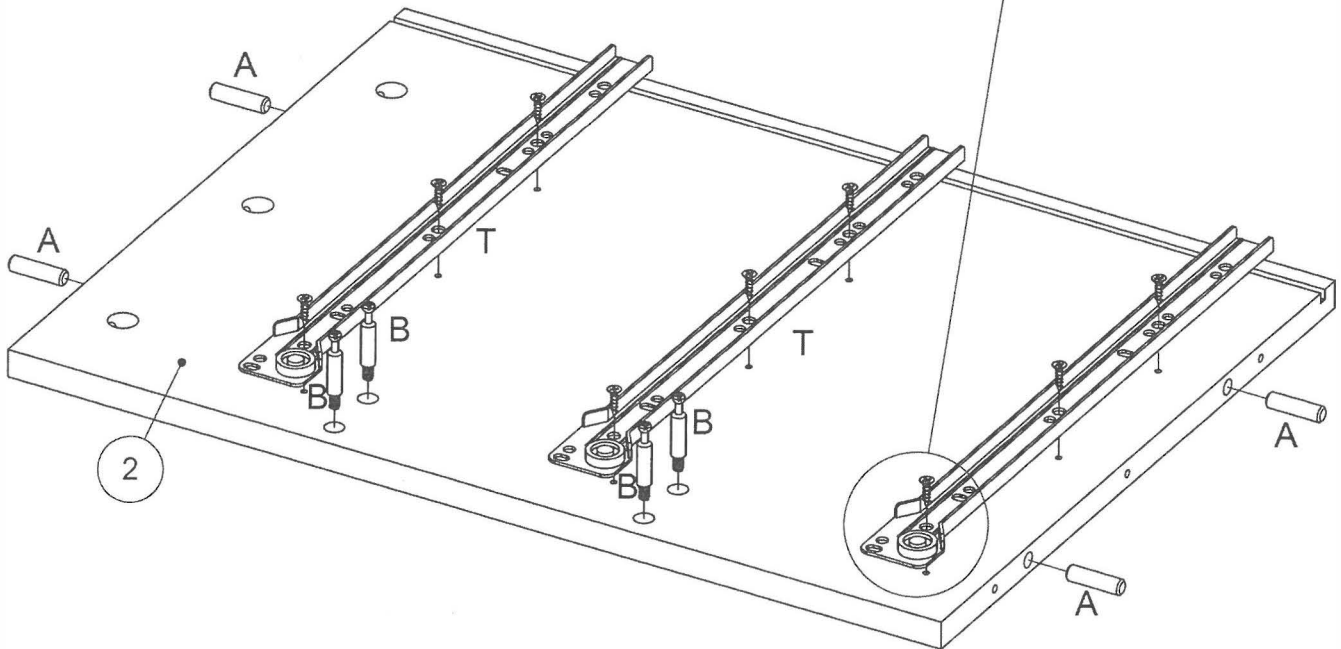
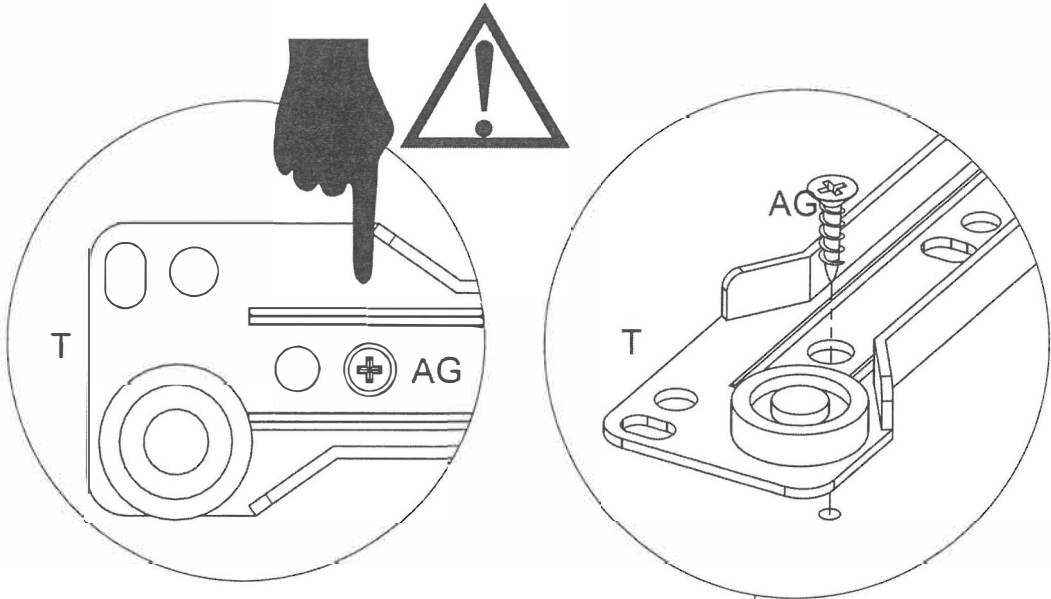
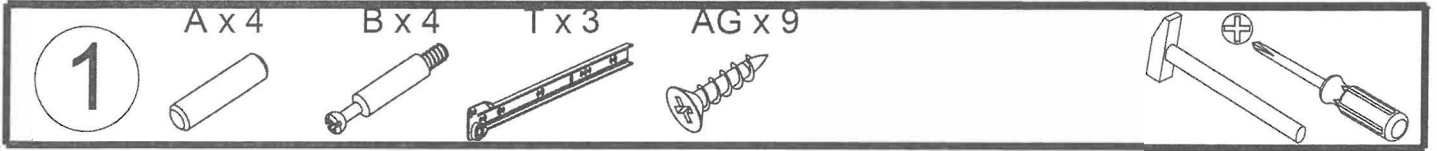

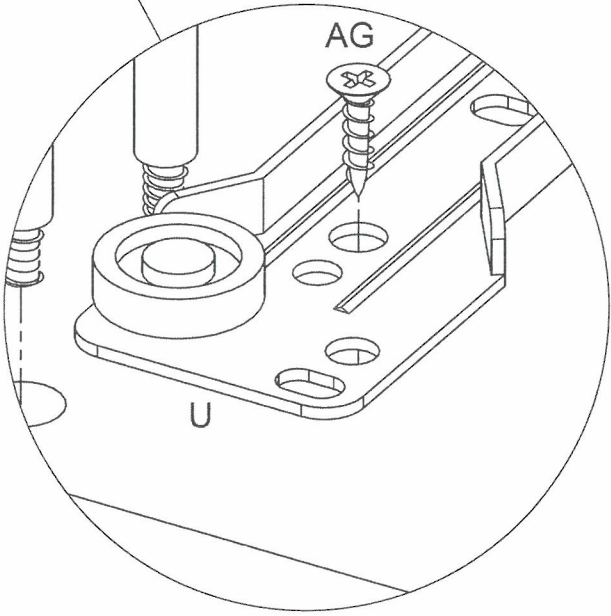
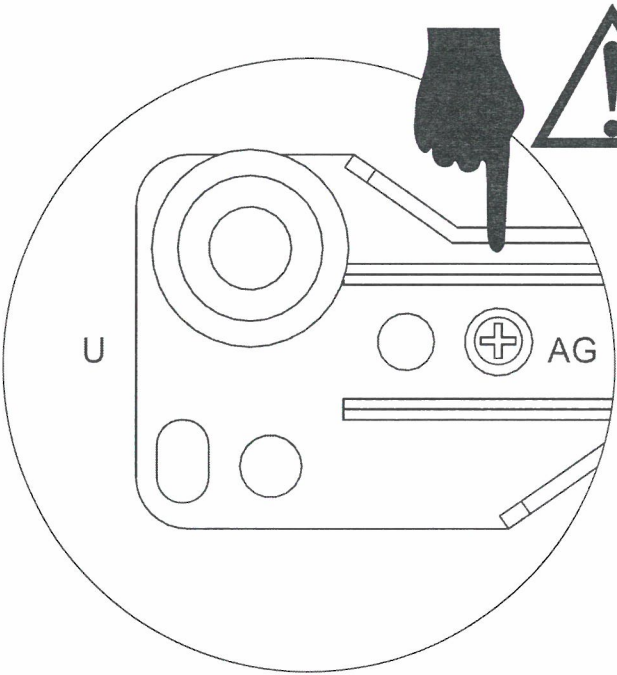
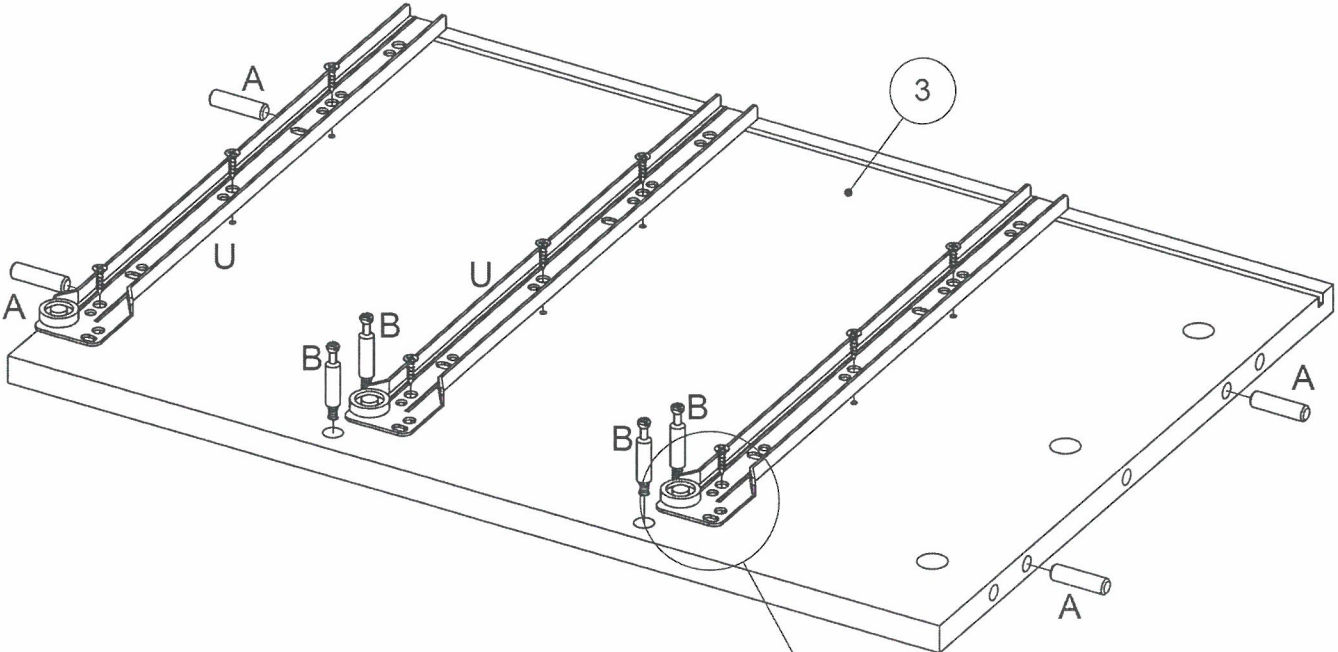
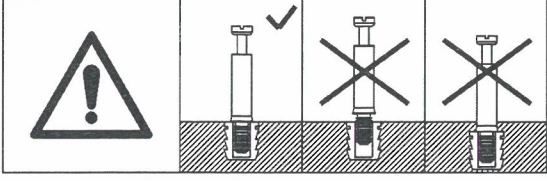
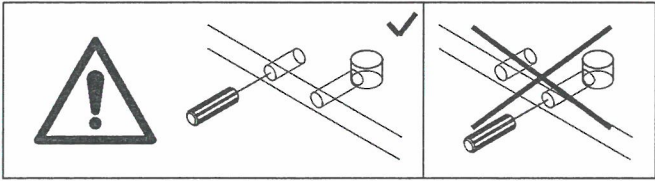
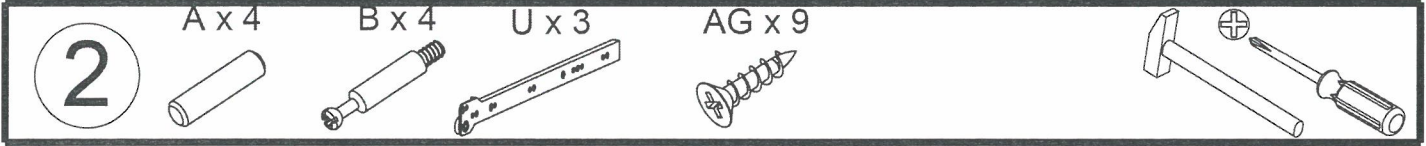

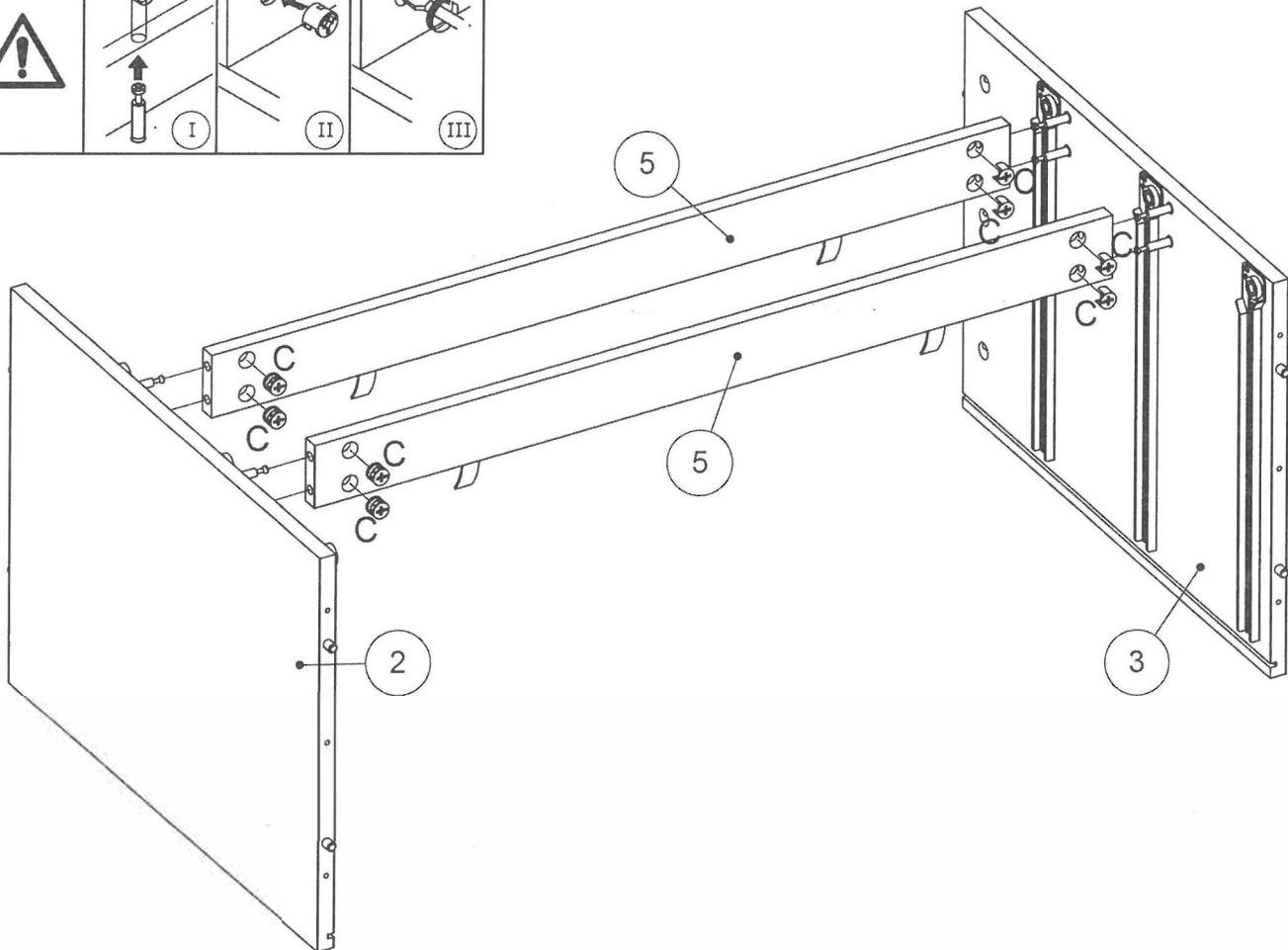
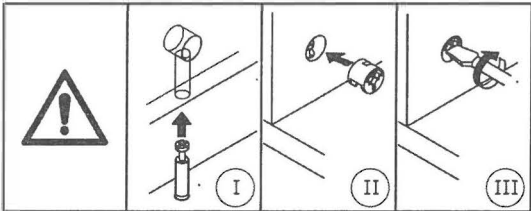
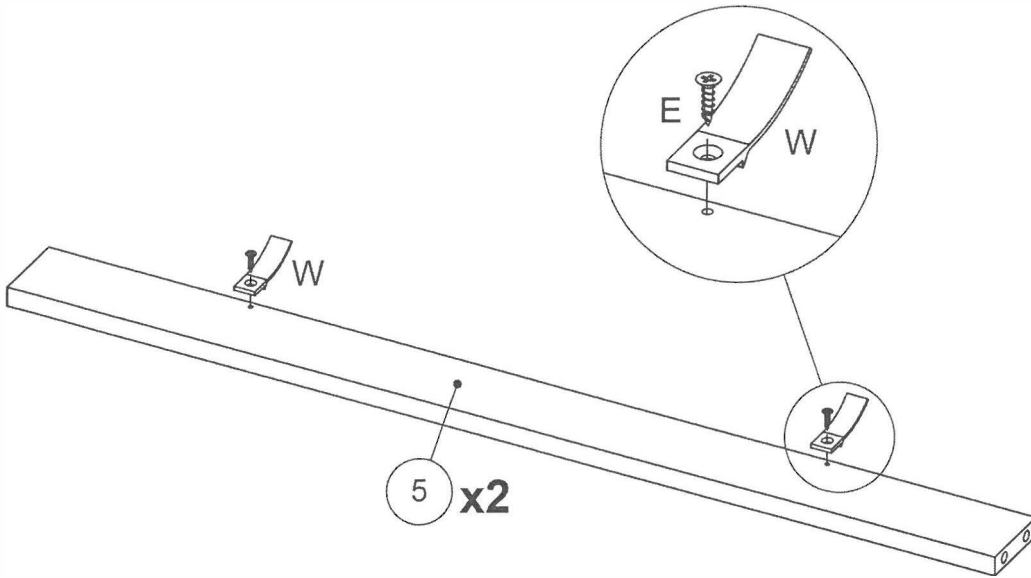

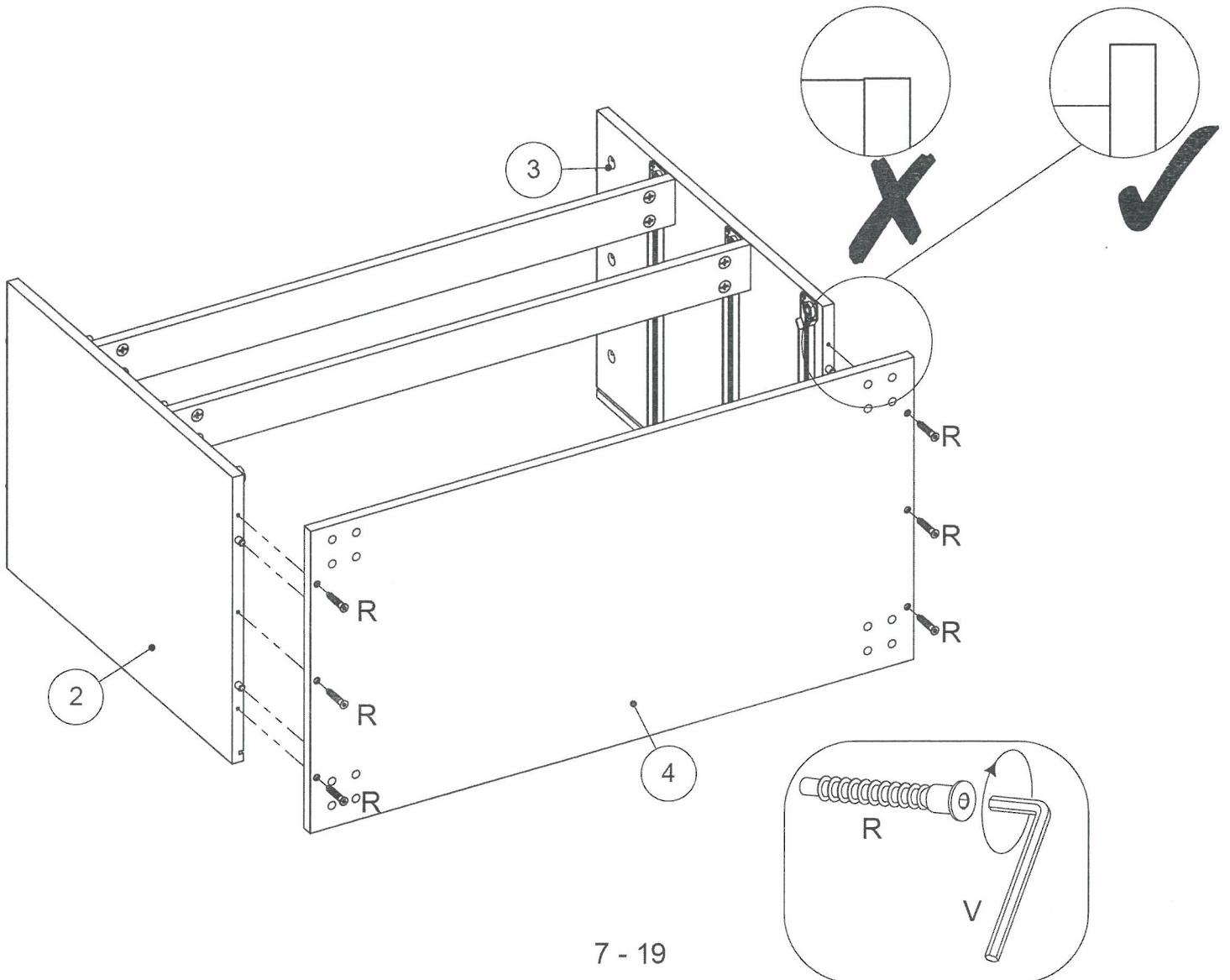
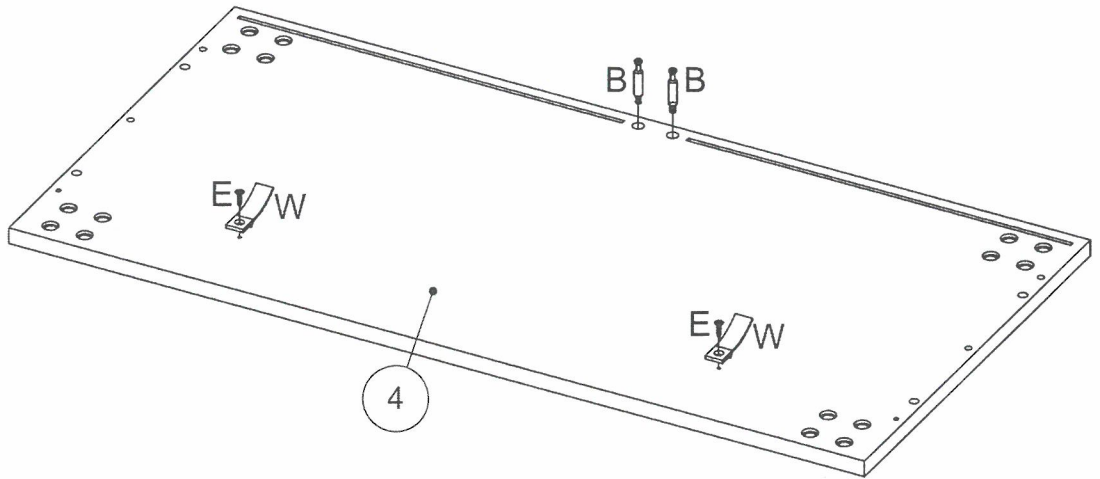

7	AR x 16	H x 16	J x 2

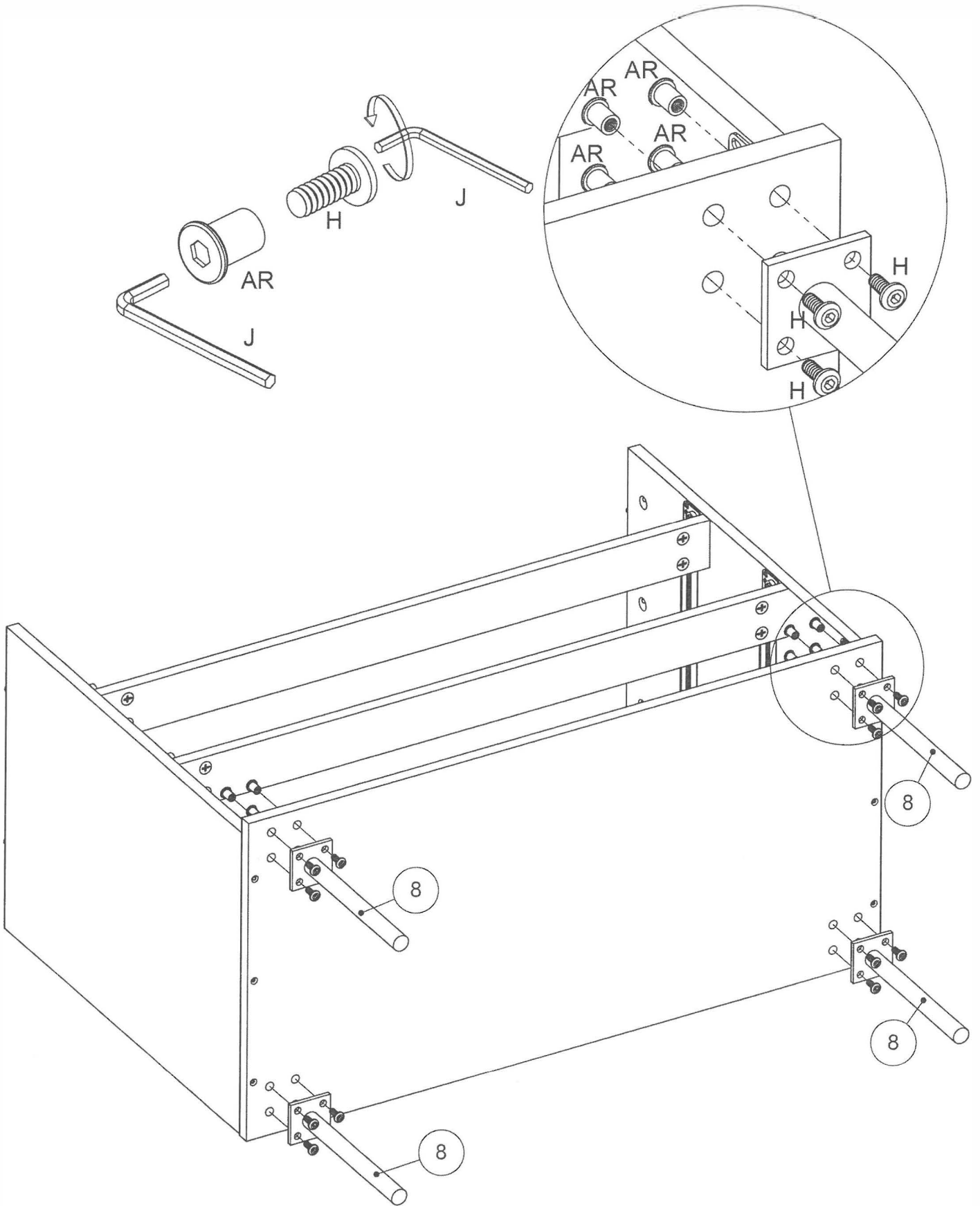

8 C x 2

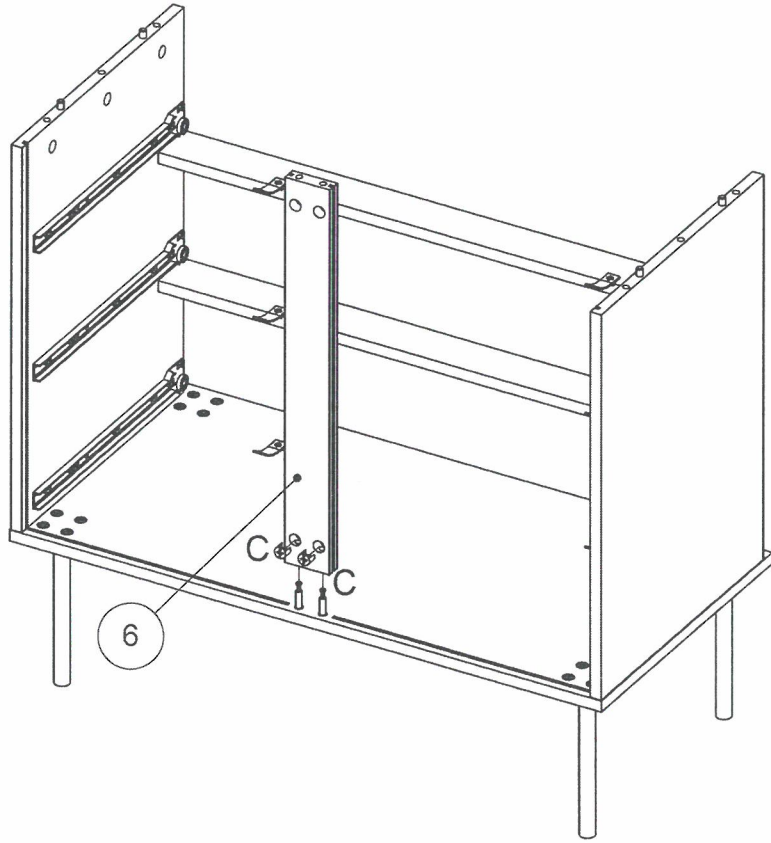

9

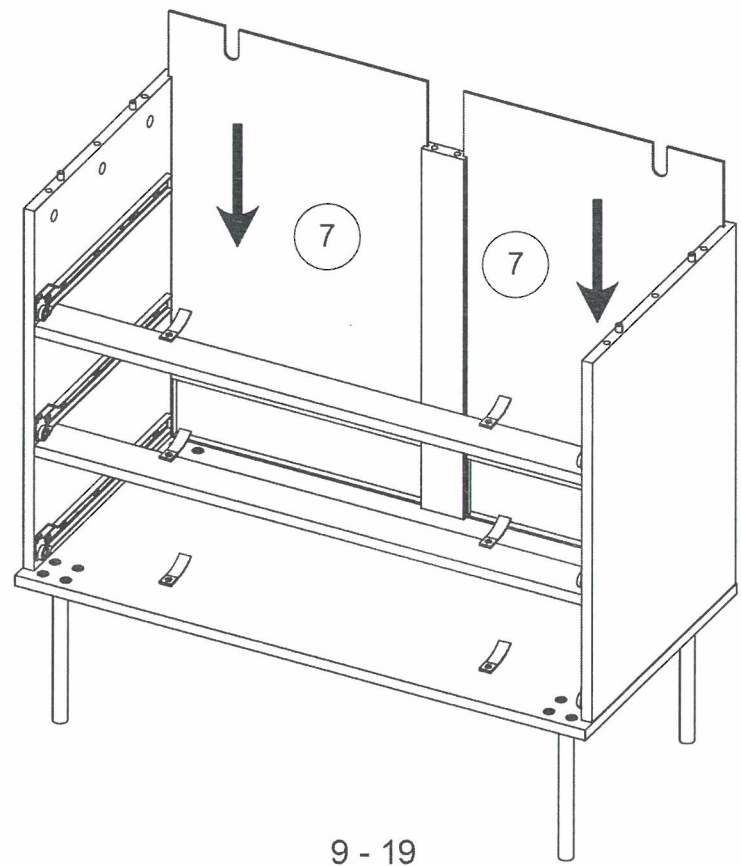

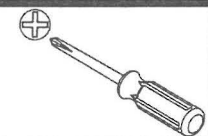
10 B x 8 D x 2 E x 4 AG x 4 

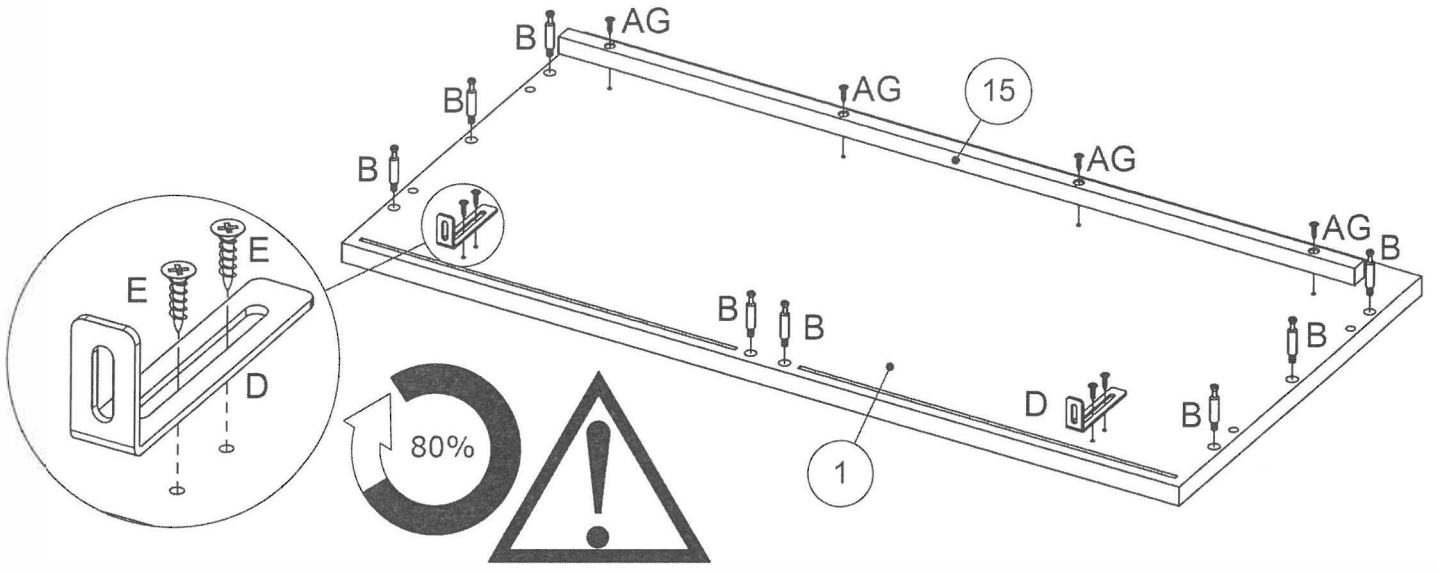

11 C x 8 

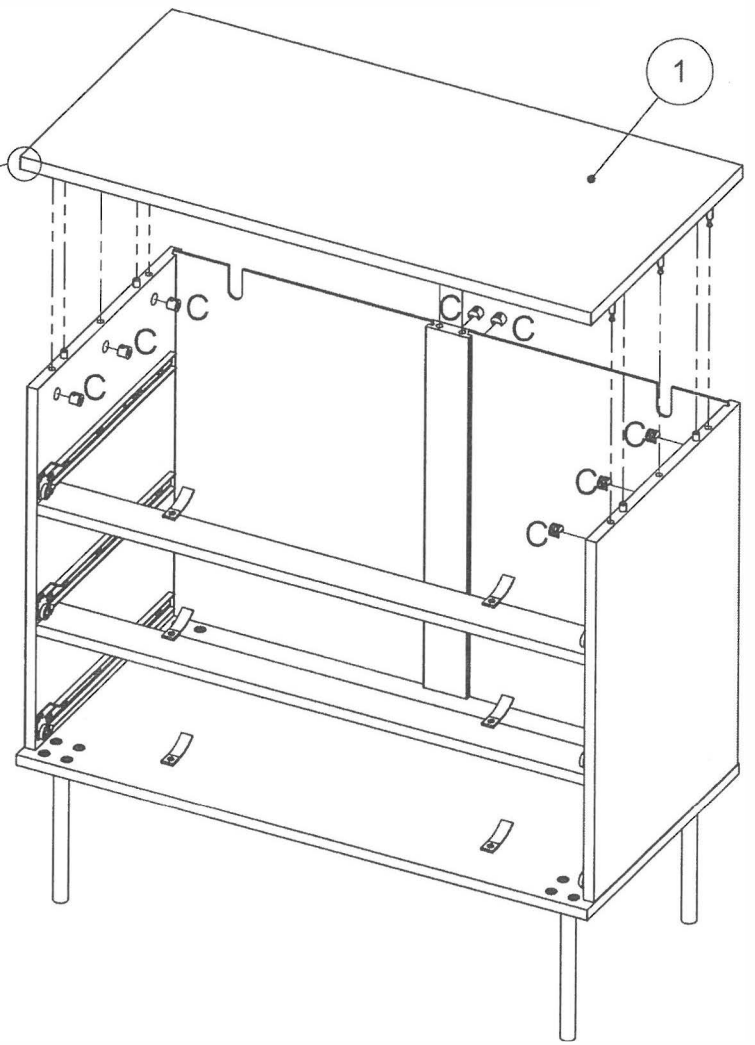
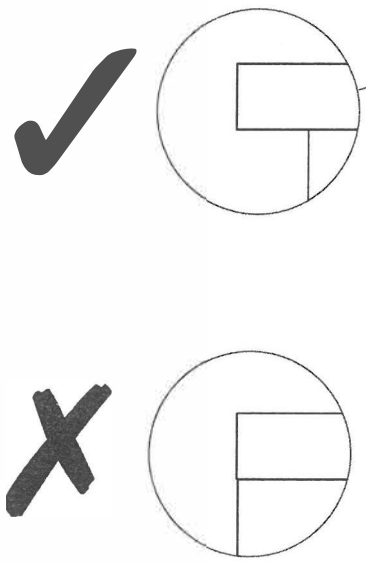

12 F x 14 Q x 4

A horizontal bar at the top of the page. On the left, a large circle contains the number '12'. To its right, the text 'F x 14' is positioned above a small trapezoidal part with a cross-shaped hole. Further right, the text 'Q x 4' is positioned above a circular disc. On the far right of the bar, there is an icon of a screwdriver with a cross-shaped bit.

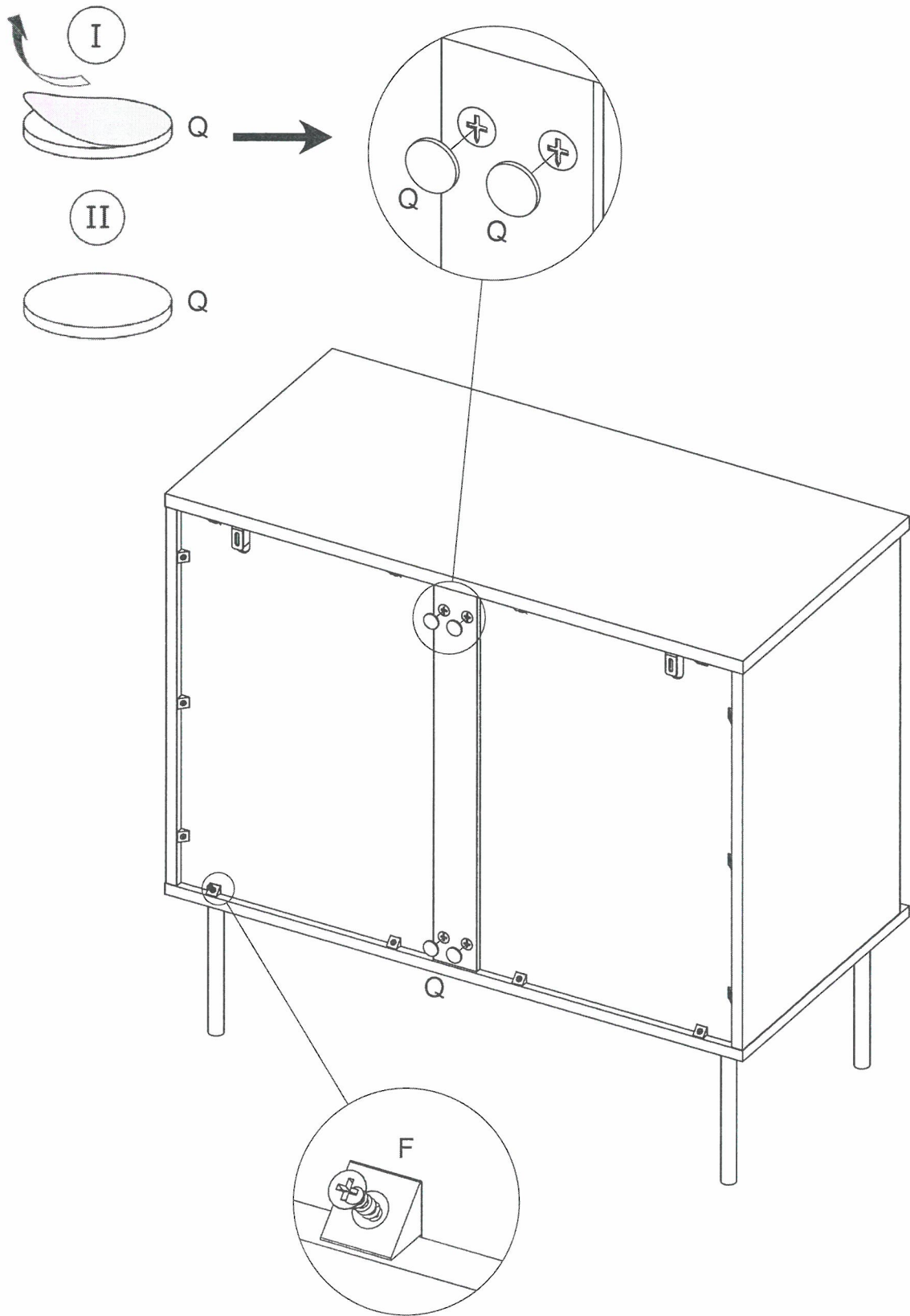

I

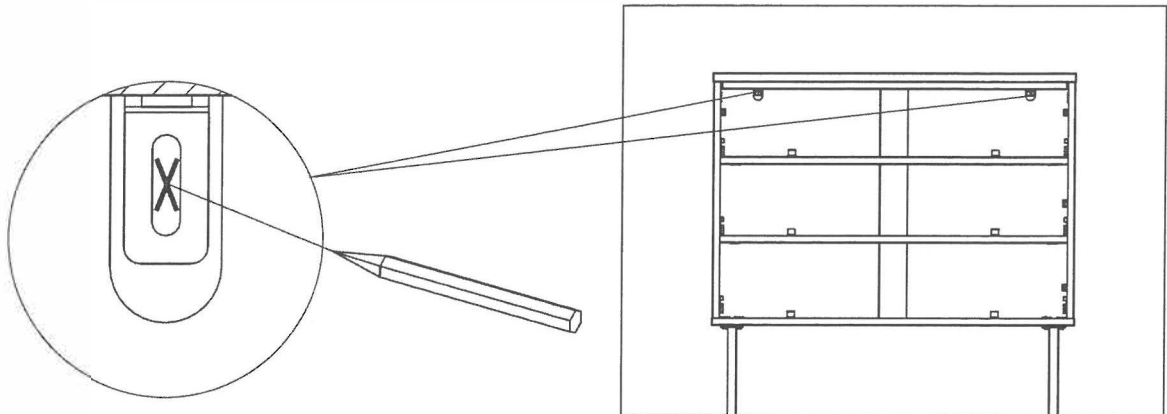

II

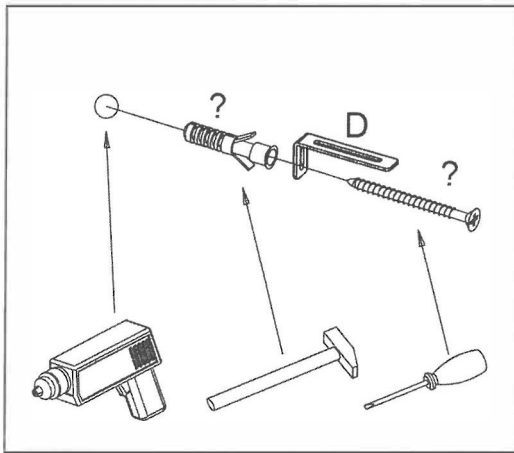

III

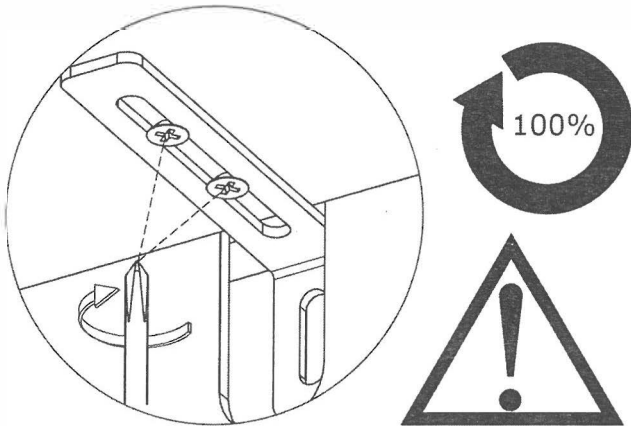

14

Q x 30

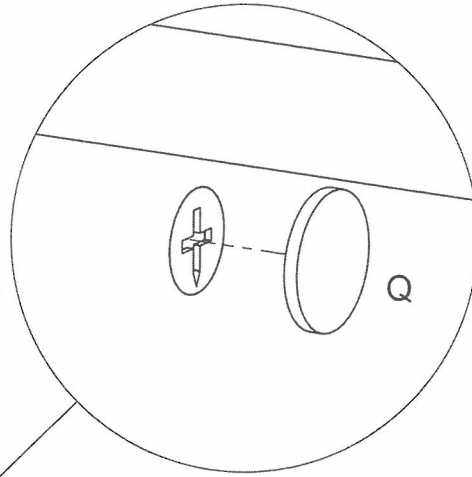
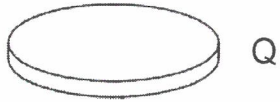
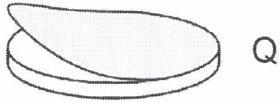



x3

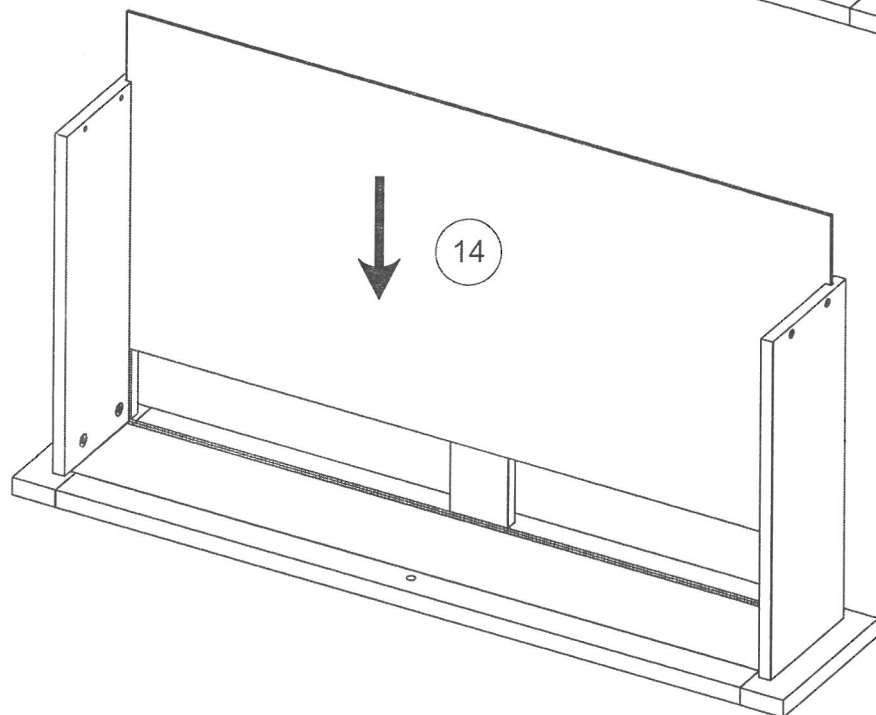
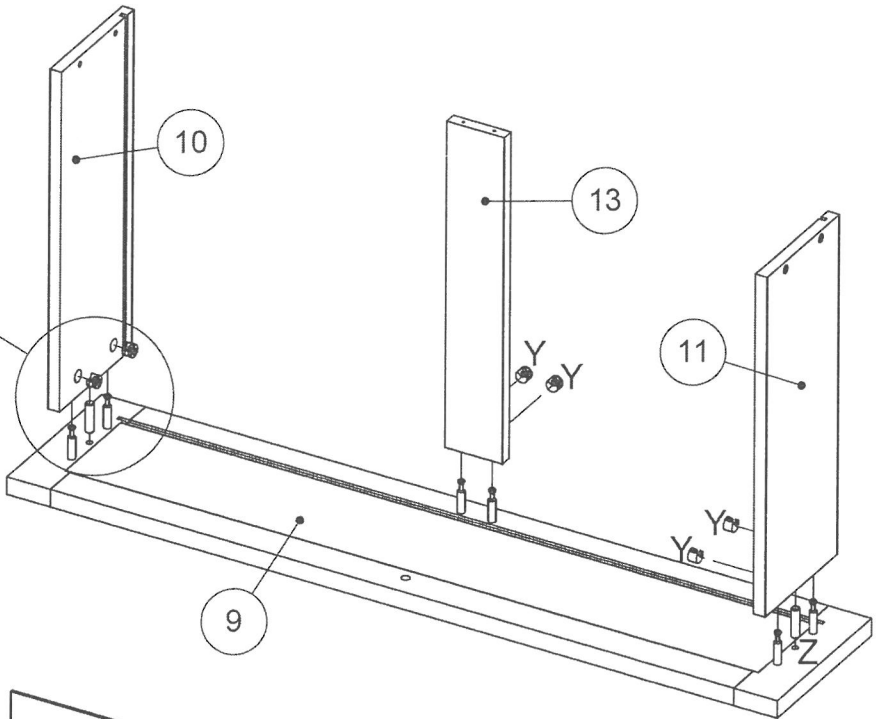
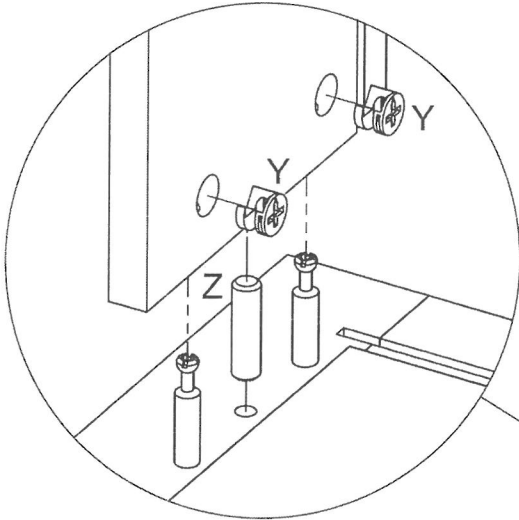
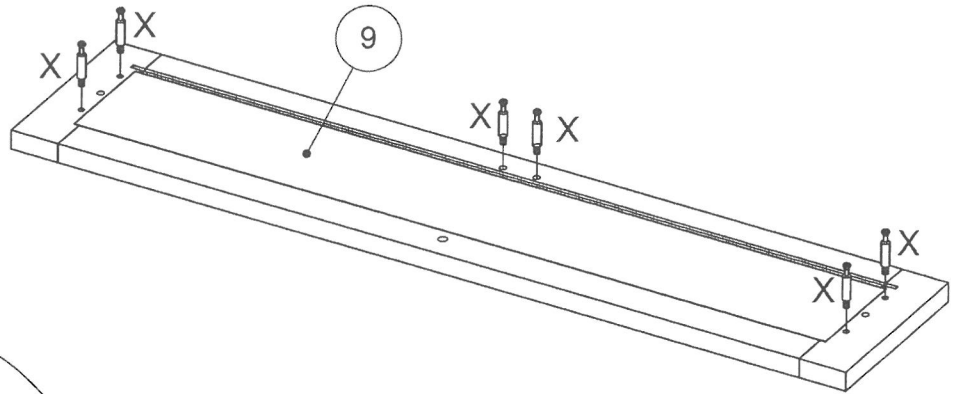

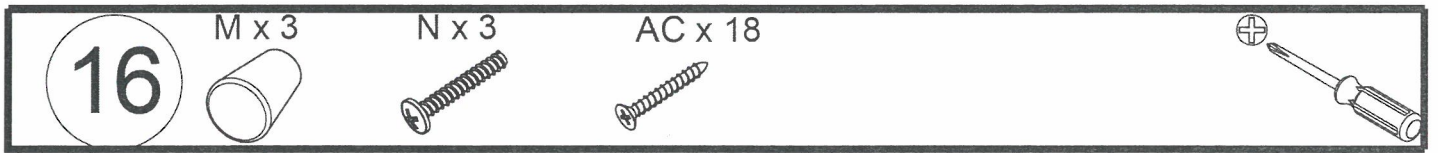

x3

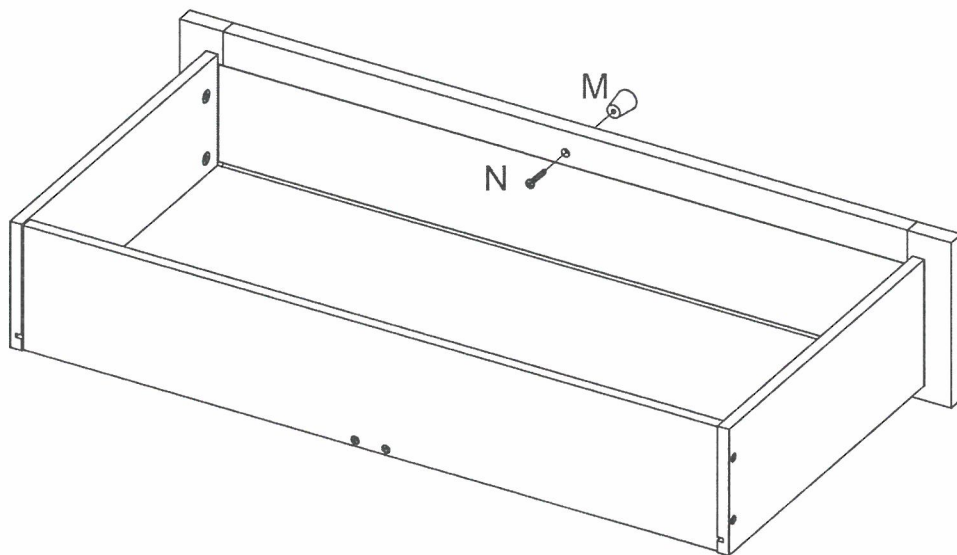
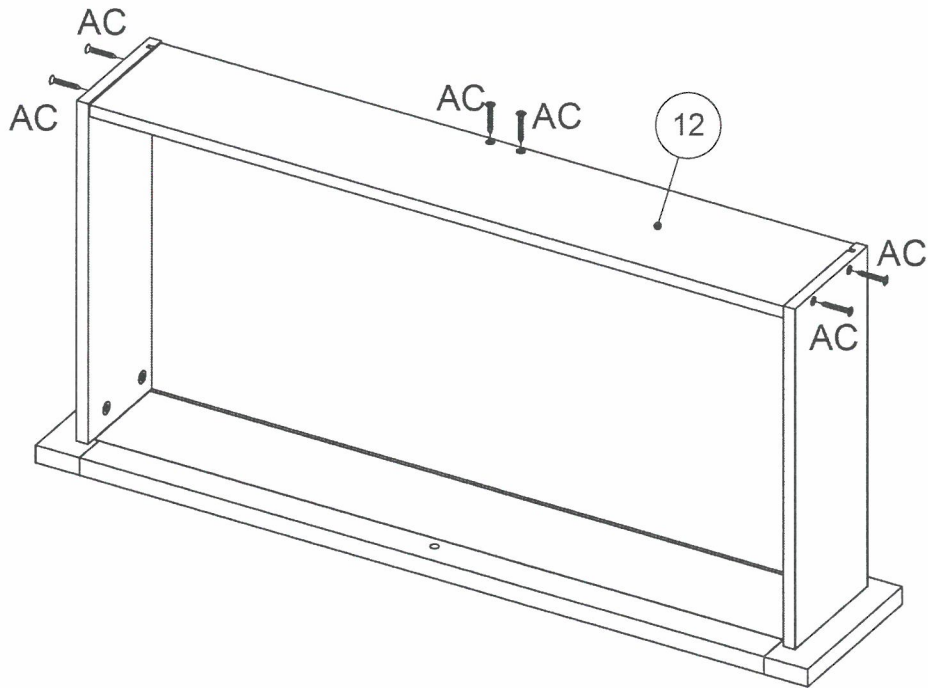

17
Q x 18
AA x 3
AB x 3
AG x 18

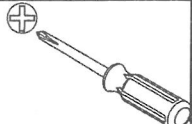

x3

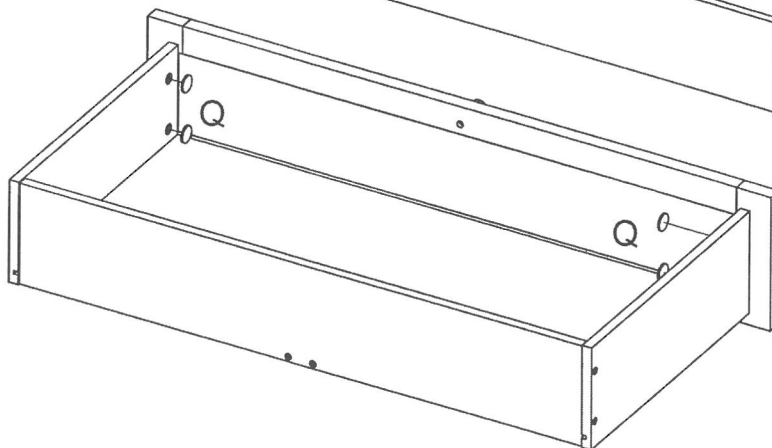
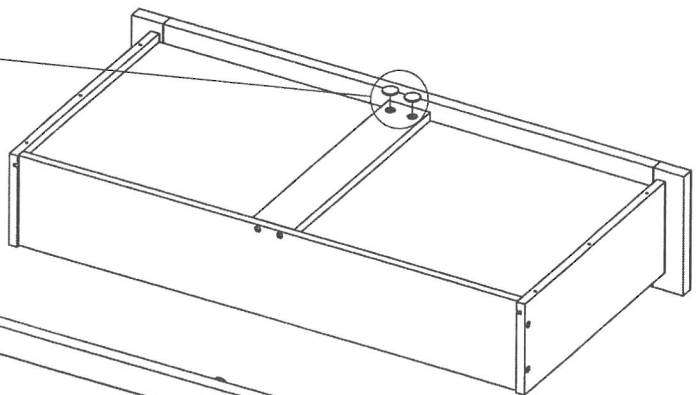
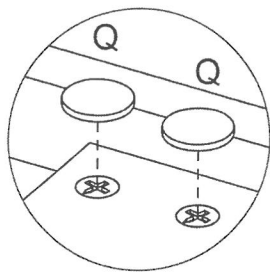
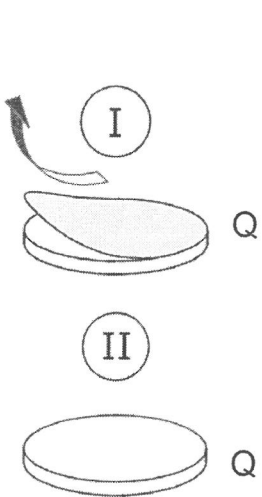
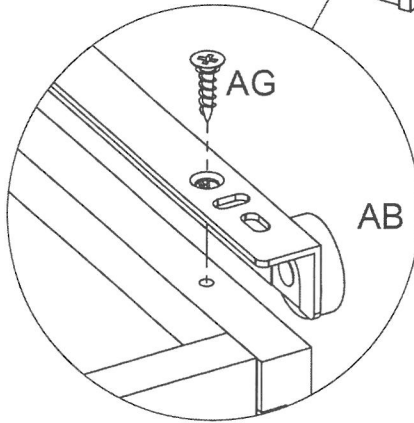
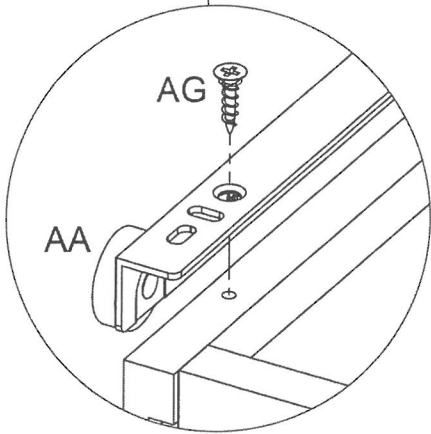
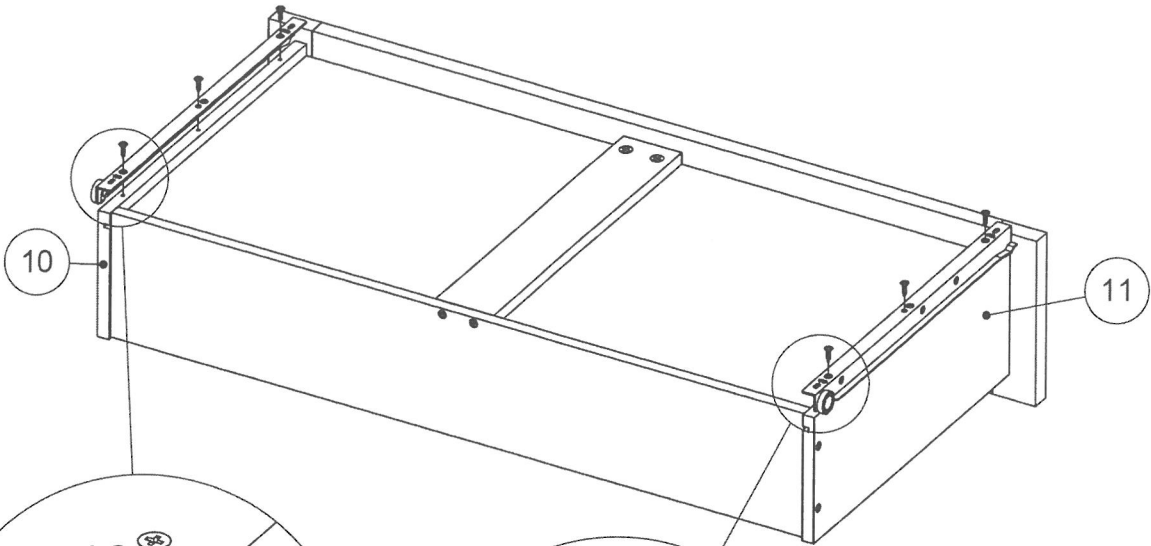

18

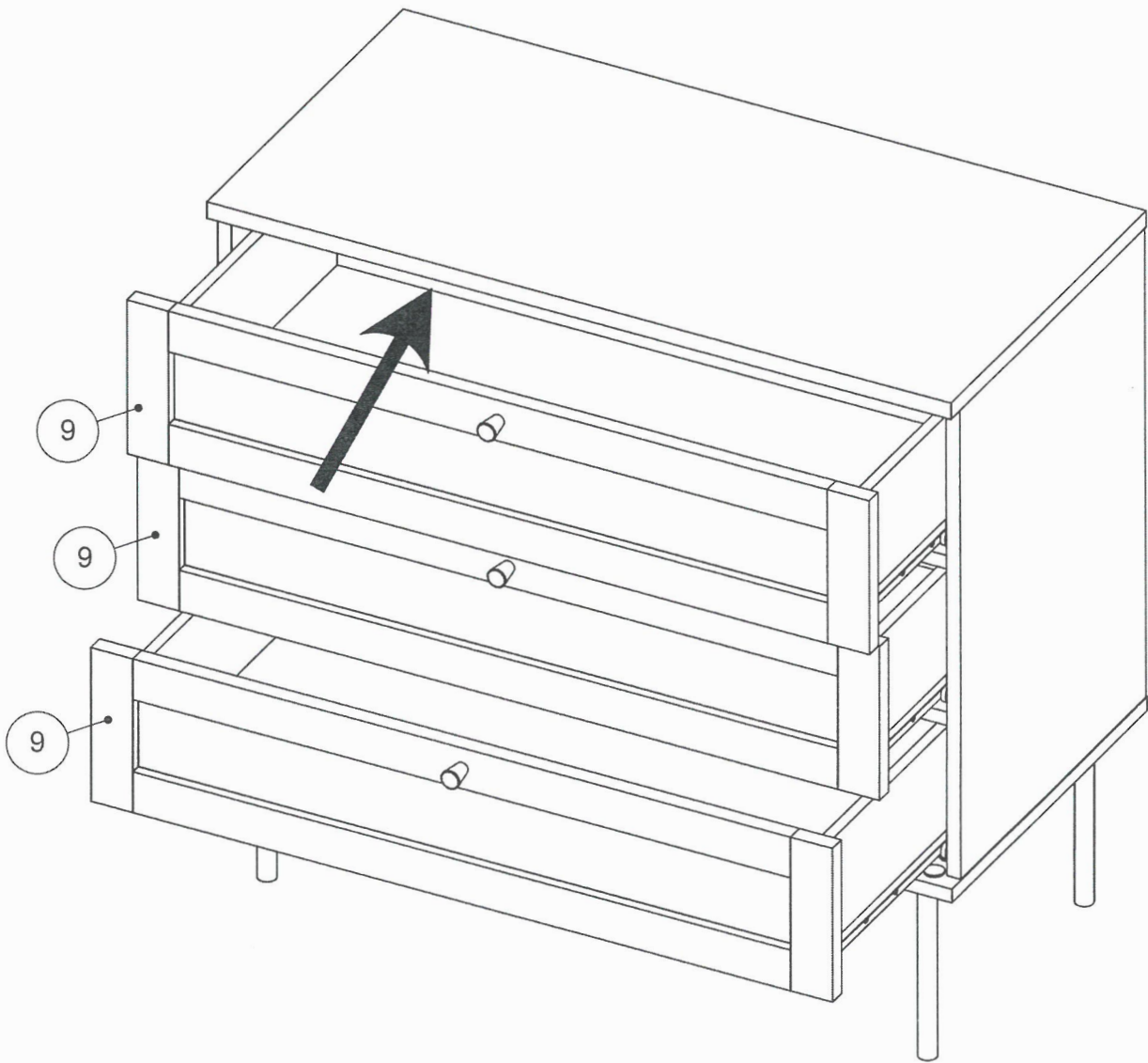

19

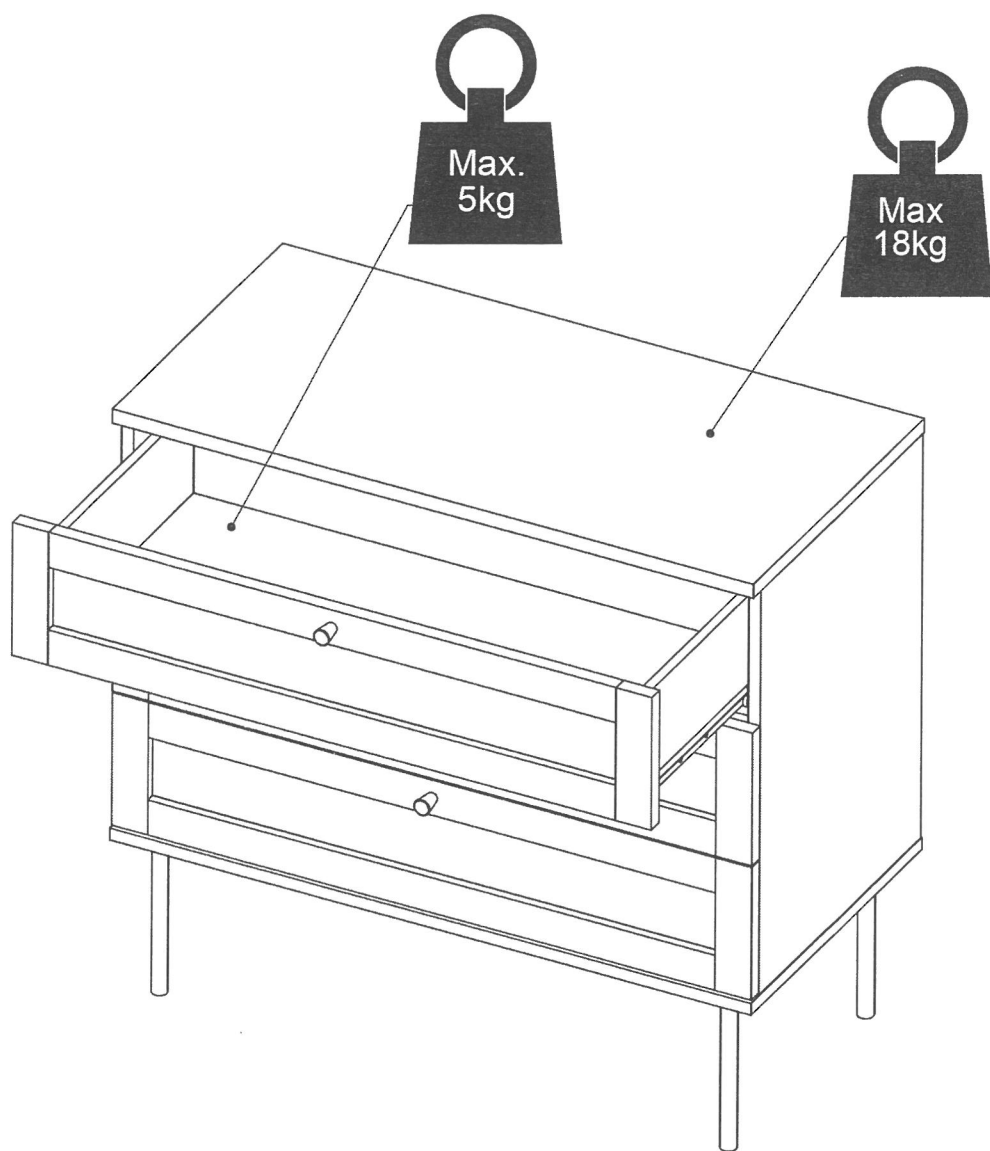



UK: To prevent the furniture from tilting it needs to be fastened to the wall using the enclosed safety string.
There are many different types of walls and partitions. We are therefore not able to enclose the correct screws and wall plugs. Before purchasing the appropriate wall plugs and screws, it is essential to find out which type of wall/partition the product needs to be fastened to. Here are some examples of recommended wall plugs/screws for:

DE: Damit das Möbelstück nicht kippen kann, muss es mit der beigegefügtten Sicherheitskette an der Wand befestigt werden. Es gibt viele verschiedene Wand- und Abtrennungsarten. Daher ist es uns nicht möglich, die korrekten Schrauben und Dübel mitzuliefern. Bevor Sie die entsprechenden Dübel und Schrauben kaufen, ist es nötig, festzustellen, an welcher Art von Wand/Abtrennung das Produkt befestigt wird. Hier finden Sie einige Beispiele für empfohlene Dübel/Schrauben für:

FR: Afin d'empêcher les meubles de basculer, ils doivent être fixé au mur à l'aide de la chaîne de sûreté fournies. Il y a beaucoup de types de murs et de cloisons différents. Nous ne sommes donc pas en mesure de joindre les vis et chevilles appropriées. Avant d'acheter les chevilles et les vis appropriées, il est essentiel de savoir quel type de mur/cloison du produit doit être fixé. Voici quelques exemples de chevilles/vis recommandées pour:

ITA: Al fine di prevenire il ribaltamento del mobile, è necessario che questo venga fissato alla parete mediante l'utilizzo della stringa di sicurezza allegata. Esistono molte tipologie di pareti e divisori. Non siamo pertanto in grado di allegare tutti i corrispettivi perni e viti di fissaggio. Prima dell'acquisto delle viti o dei perni più appropriati, è necessario individuare il tipo di parete/divisorio a cui il prodotto deve essere fissato. Forniamo di seguito alcuni esempi di perni/viti raccomandati per:

ES: Para evitar que los muebles queden inclinados, estos tienen que fijarse a la pared, usando el cordón de seguridad incluido. Existe una variedad infinita de paredes y tabiques. Por tanto nosotros no somos capaces de incluir los tornillos y tacos de pared apropiados. Antes de comprar los tacos y tornillos de pared correctos, es esencial saber el tipo de pared/tabique al que hay que fijar el producto. He aquí algunos ejemplos de los tacos/tornillos de pared recomendados para:

CAT: Per tal d'evitar que el moble s'inclini, cal collar-lo a la paret amb el cordó de seguretat inclòs. Hi ha diferents menes de parets i envans. Per aquest motiu no podem incloure els cargols i els tacs adequats per a totes les parets. Abans de comprar els cargols i els tacs adequats, cal esbrinar a quina mena de paret o envà anirà muntat el producte. Aquí teniu alguns exemples de cargols i tacs recomanats per a:

UK: Brick Walls DE: Ziegelwände FR: Murs de briques ITA: Pareti di mattoni ES: Paredes de ladrillo CAT: Pareds de totxo				
UK: Nylon Plug "Fisher" DE: Nylon-Dübel "Fischer" FR: Cheville en nylon à expansion "Fisher" ITA: Prese "Fisher" in nylon ES: Taco de Nylon "Fischer" CAT: Tac de niló "Fisher"	Metal expansion bolt Metall-Dehnschraube Boulon à expansion en métal Perni ad espansione in metallo Taco metálico expansible Cargol d'expansió metàl·lic	Nylon expansion bolt Nylon-Dehnschraube Boulon à expansion en nylon Perni ad espansione in nylon Taco expansible de nylon Cargol d'expansió de niló	Cavity anchor Hohlraumdübel Cheville de verrouillage Cavità di ancoraggio Anclaje de pared hueca Ancoratge per a cavitats	Cavity anchor "Molly" Hohlraumdübel "Molly" Cheville de verrouillage de forme "Molly" Cavità di ancoraggio "Molly" Anclaje de pared hueca "Molly" Ancoratge per a cavitats de tipus "Molly"



UK: Use a drill suitable for the type of wall and the chosen wall plug.
 DE: Verwenden Sie einen für die Wand und die gewählte Dübelart passenden Bohrer.
 FR: Utiliser une perceuse appropriée pour le type de mur et la prise murale choisie.
 ITA: Utilizzare un trapano adatto al tipo di parete e al tipo di perno selezionato.
 ES: Utilice una máquina taladradora adecuada para el tipo de pared y el taco preferido.
 CAT: Cal fer servir una broca adequada per al tipus de paret i el tac escollit.