

USARE TWIGGY_LESS
USING TWIGGY_LESS

Interruttore touch & memoria di luminosità
Touch Switch & Brightness memory

Memoria di luminosità: ogni volta che accendi la lampada, l'intensità luminosa è la stessa dell'ultimo utilizzo.
Brightness memory. Everytime you switch the lamp on, the lighting brightness is the same as the previous setting.

Dimmerazione touch omogenea
Stepless touch dimmer

Con la lampada al 100% di intensità luminosa, l'autonomia operativa è di 9 ore.
With the device at 100% light intensity, the cordless operating autonomy is 9 hours.

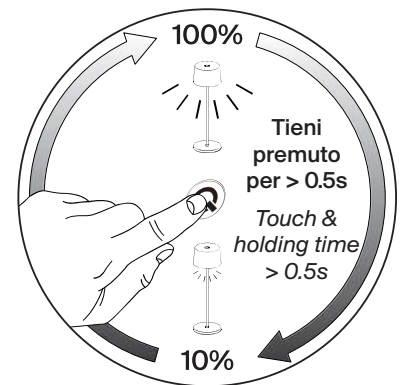
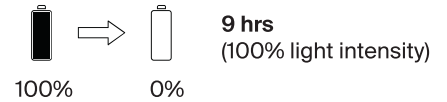
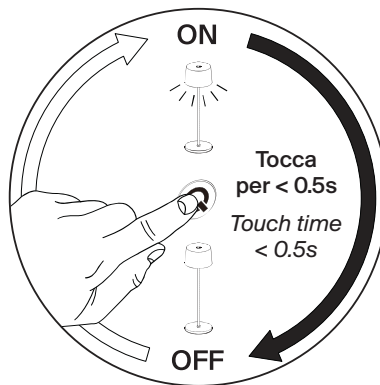
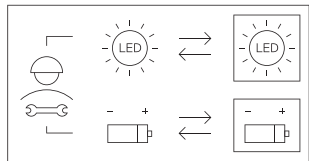
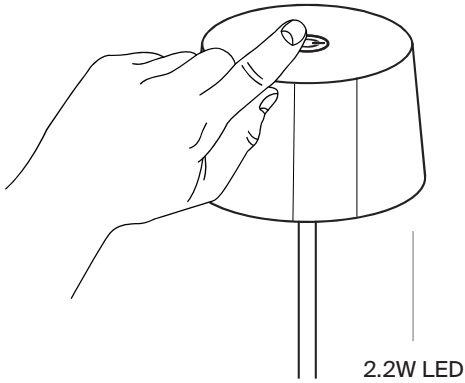

Funziona solo quando la lampada è accesa
It only works when the light is on

TEMPERATURA COLORE LUCE
COLOUR TEMPERATURE

Interruttore CCT
CCT Switch

Impostazione della temperatura colore. Tieni premuto per più di 4s per attivare la modalità CCT; quando la luce blu si accende, la modalità è attiva. Tocca per <0.5s per cambiare temperatura (2700K oppure 3000K).
Hold the switch for more than 4 seconds to activate the CCT changing mode. When the switch turns blue the CCT mode is ON. Now simply touch the switch for <0,5s to select the colour temperature (either 2700K or 3000K).



BLUE → CCT MODE ON

Funziona solo quando la lampada è spenta
It only works when the light is off

CCT AUTO OFF

Se non viene effettuata nessuna operazione entro 10 secondi, la lampada uscirà automaticamente dalla funzione di selezione della temperatura colore.
If there is no operation within 10 seconds, the lamp will automatically quit from the colour temperature switching mode.

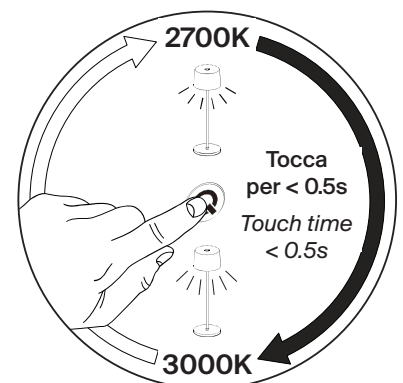
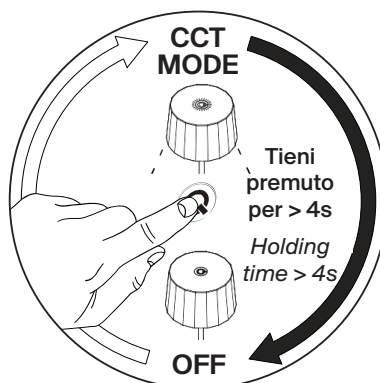

RICARICA TWIGGY_LESS

RECHARGING TWIGGY_LESS



ARANCIONE ON →
RICARICA IN CORSO
ORANGE ON →
RECHARGE IN PROGRESS



ARANCIONE OFF →
RICARICA TERMINATA
ORANGE OFF →
RECHARGE COMPLETED



Adattatore USB
DC5V 1A
USB Adapter
DC5V 1A

Base di ricarica
con cavo USB 1.5m
Cordless charging
base with 1.5m
USB cable

Ricarica batteria

Battery Recharge

Appoggiare Twiggy_Less sulla base di ricarica collegata alla corrente. La fase di ricarica è indicata dal colore giallo dell'interruttore di accensione. Quando è completamente carica, l'interruttore si spegne.

Place Twiggy_Less on the recharging base connected to power. When charging the switch turns orange. When battery is completely charged, the light on the switch turns off.

Capacità batteria

Battery Capacity

2200 mAh x2
Batteria al litio ricaricabile
Built in rechargeable lithium battery

Massimo 6 ore/ Max 6hr

Il tempo necessario per la carica completa è di 6 ore.

The complete recharging time is 6 hours

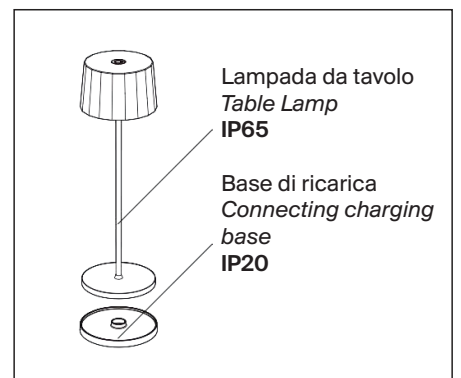
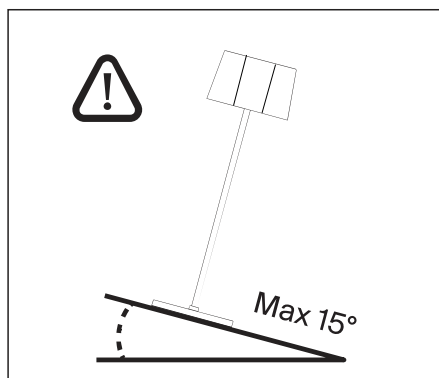
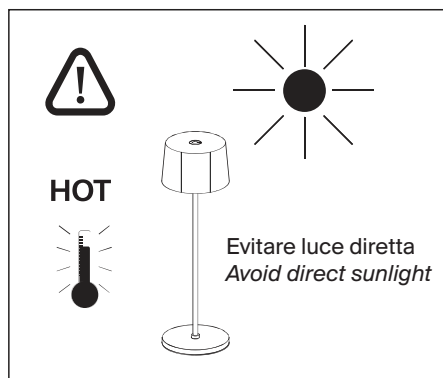
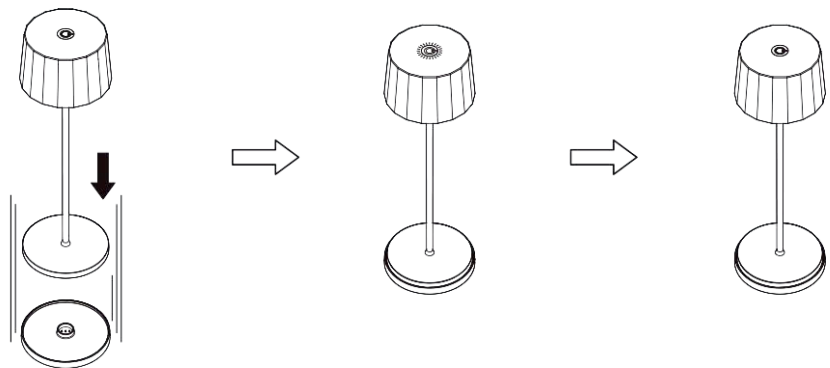
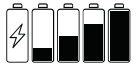

Questo prodotto contiene una fonte luminosa di Classe Energetica F.

This product contains light source of Energy Efficiency Class F.

Il simbolo  riportato sull'apparecchio indica che il prodotto deve essere smaltito in modo differenziato dai rifiuti urbani

This symbol  shown on the device indicates that the product must be disposed of in a way which differs from the standard urban rubbish.

www.logicailuminazione.com



LOGICA

Logica è un marchio di Marino Cristal S.p.A.

Marino Cristal S.p.A.
Via Guardia del Consiglio 31
47899 Serravalle
Repubblica di San Marino

info@logicailuminazione.com

TWIGGY_LESS

LED 2.2W 150lm 3.7V 2700/3000K(Module 1.8W 217 lumen)

LOGICA

BATTERY REPLACEMENT INSTRUCTIONS ISTRUZIONI SOSTITUZIONE BATTERIA

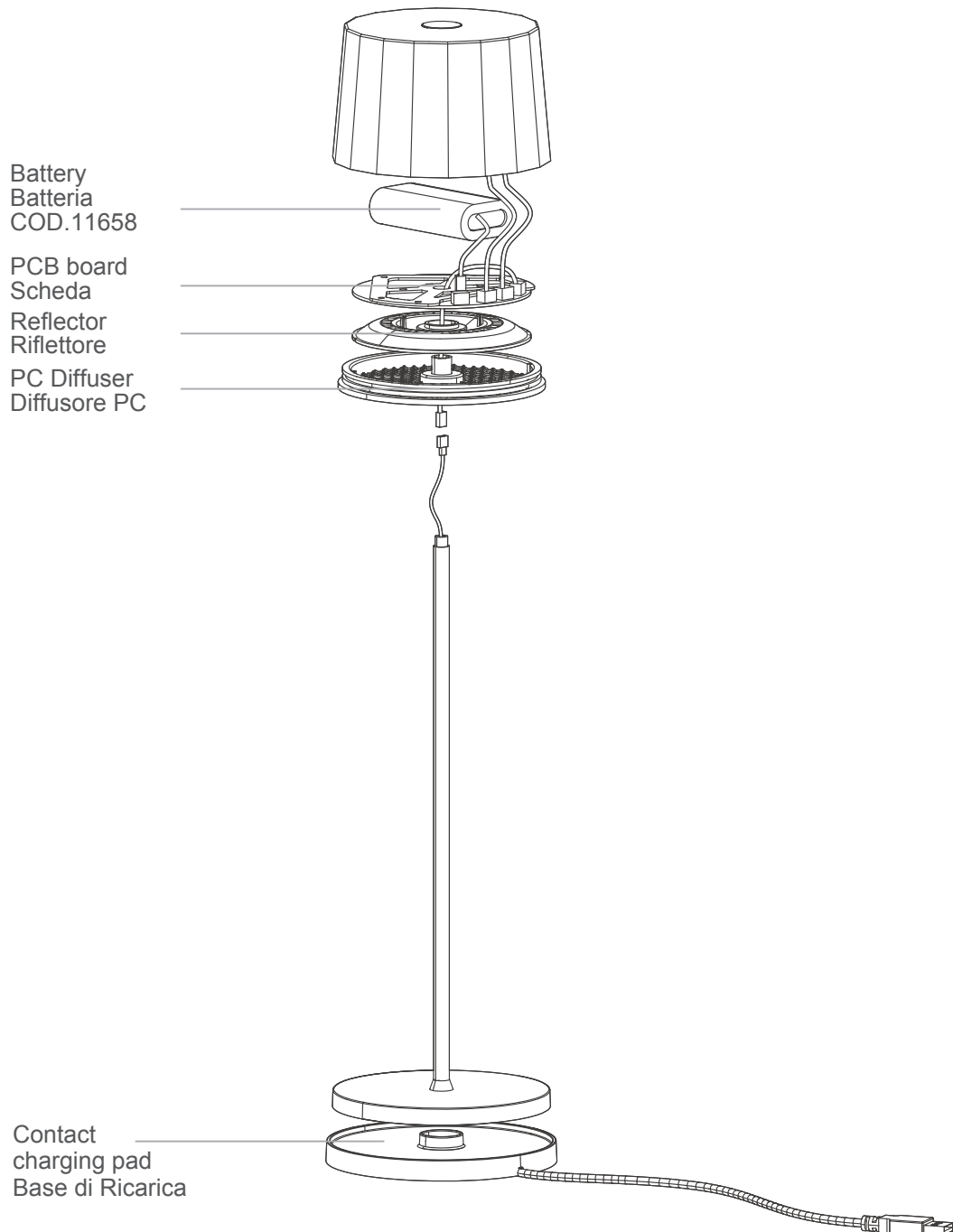

LOGICA è un marchio di:
MARINO CRISTAL SPA
Via Guardia del Consiglio, 31
47899 Serravalle Repubblica di San Marino

STEP 1

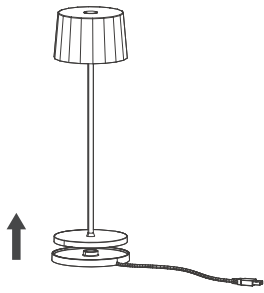

STEP 2

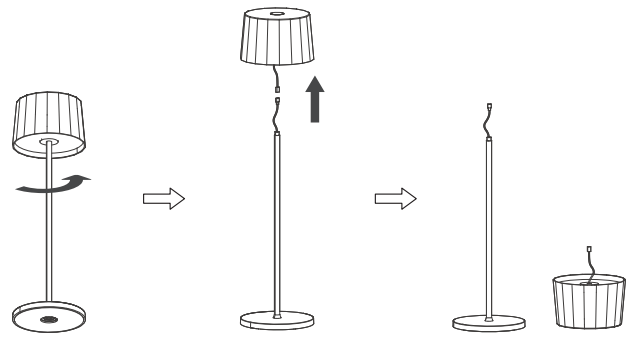

STEP 3

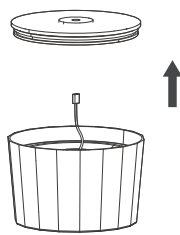

STEP 4

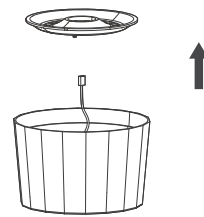

STEP 5

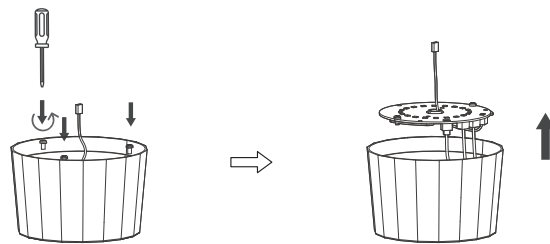

STEP 6

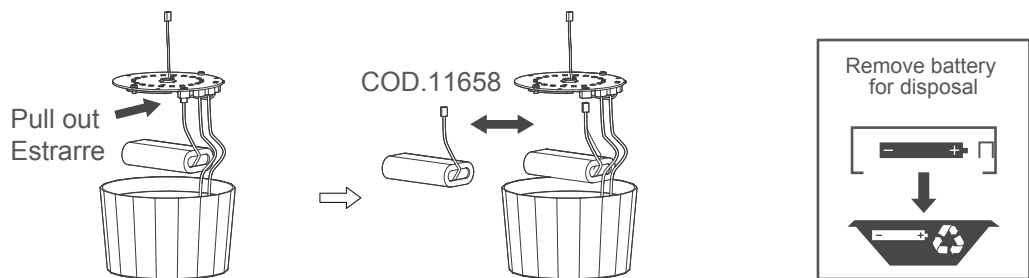

STEP 7

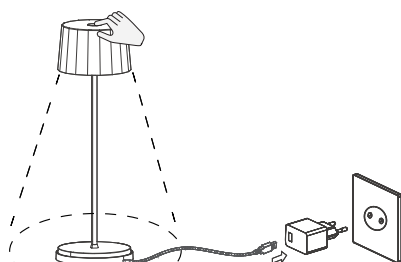

LOGICA è un marchio di:
MARINO CRISTAL SPA
Via Guardia del Consiglio, 31
47899 Serravalle Repubblica di San Marino

