

88480207A

## Wohnen

### Filigno Vitrine

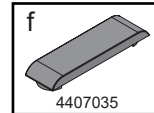
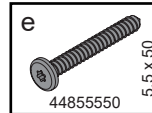
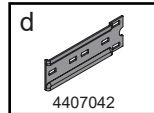
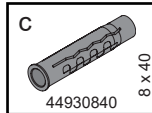
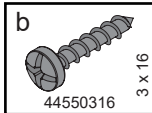
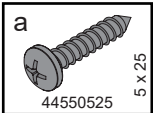
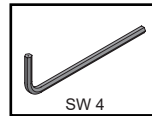
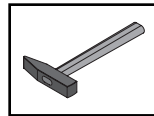
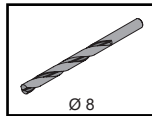
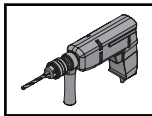
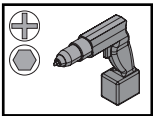
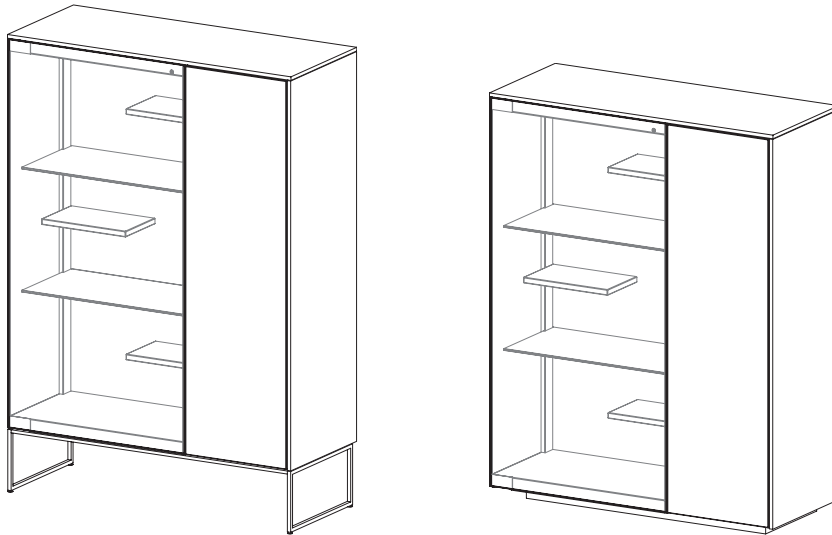

### ⚠ ACHTUNG

- Beiliegendes Material eignet sich nur für Beton-, Vollziegel- und Hochlochziegel\*- Wände. Für andere Wandtypen müssen Spezialdübel verwendet werden.
- Dabei ist vom Fachmann die Eignung des Untergrundes zu prüfen und zu kontrollieren, ob die Befestigungsmittel den auftretenden Kräften standhalten!
- Wird dieser Sicherheitshinweis nicht durchgeführt, übernimmt TEAM 7 keine Produkthaftung!
- Alle elektrischen Arbeiten sind von einer entsprechenden Fachkraft durchzuführen!
- Öffnen sie niemals ein Netzgerät. Es besteht Lebensgefahr!
- Die Summe der Wattanzahl der Spots, darf die Wattleistung des Trafos, beziehungsweise der Funkeinheit nicht übersteigen.
- Wenn kein Kabeldurchlass vorgesehen ist mit Stichsäge einschneiden.
- \* bei Hochlochziegel ohne Schlag bohren!

### ⚠ HINWEIS

- Pflegeanleitungen (Naturholz-, Leder-, Stoff-, Stricktex-, Stein-, Glas-, Filz-, Keramik-, Metall-, und Arbeitsplattenpflege) entnehmen Sie bitte der TEAM 7 Homepage.
- Wichtige produkt und warentypische Eigenschaften der TEAM 7 Naturholzmöbel finden Sie auch in unserem Service- und Gütepass unter:

<http://www.team7.at/de/ueber-uns/service/service-und-guetepass>



## 1. Übersicht Sockel

Metallrahmengestell

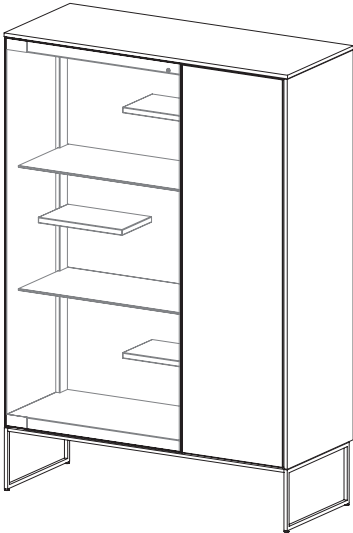

Rückspringender Sockel

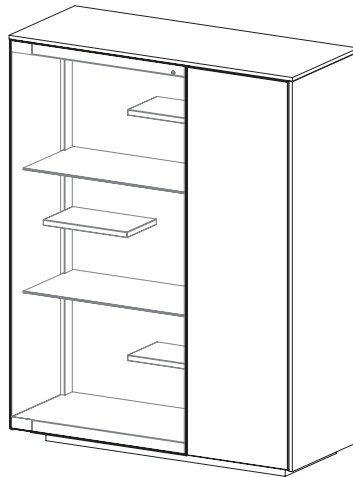

## 2. Metallrahmengestell montieren

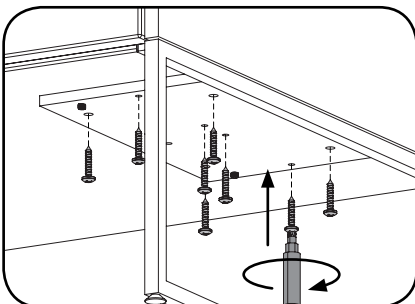
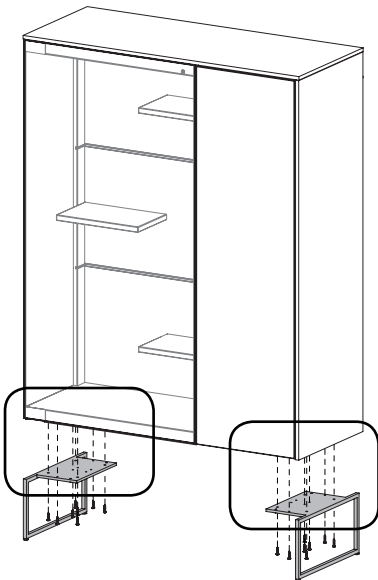
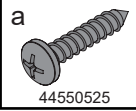

## 2. Metallrahmengestell montieren

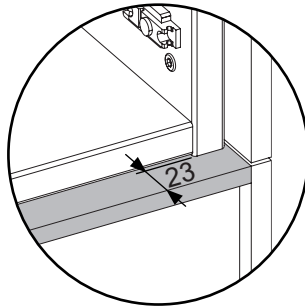
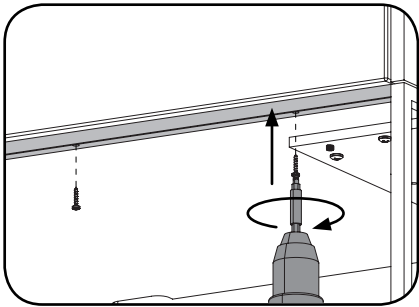
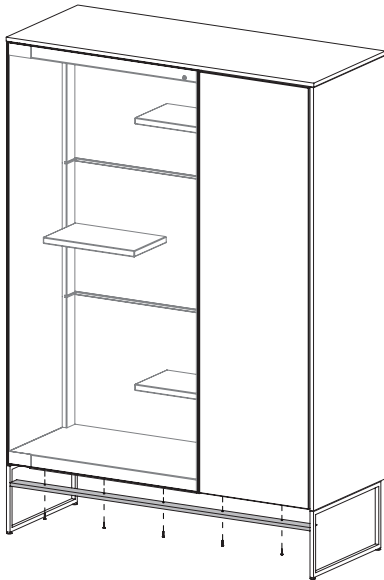
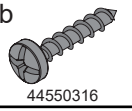

Alle Maße in Millimeter

## 3. Ober- und Unterboden demontieren

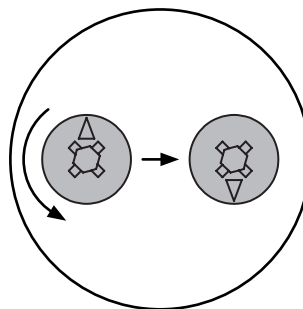
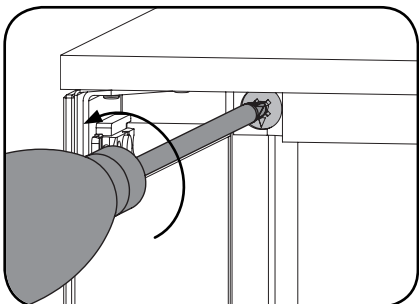
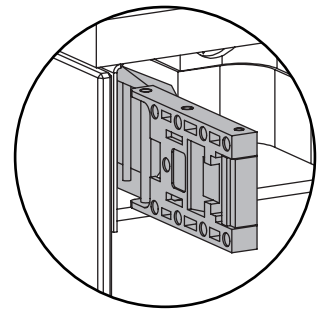
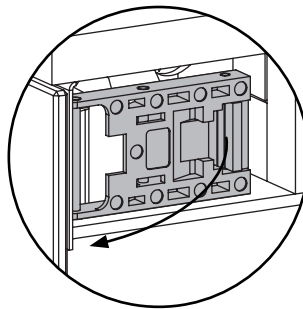

### 3.1 Oberboden demontieren

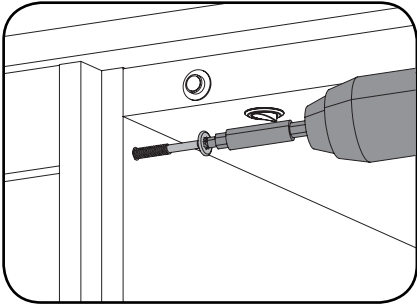
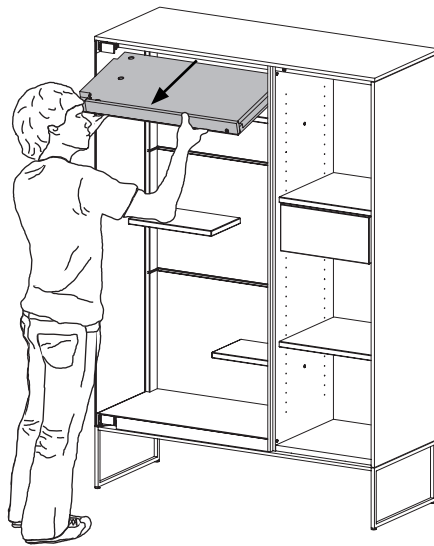
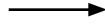

### 3.2 Unterboden demontieren

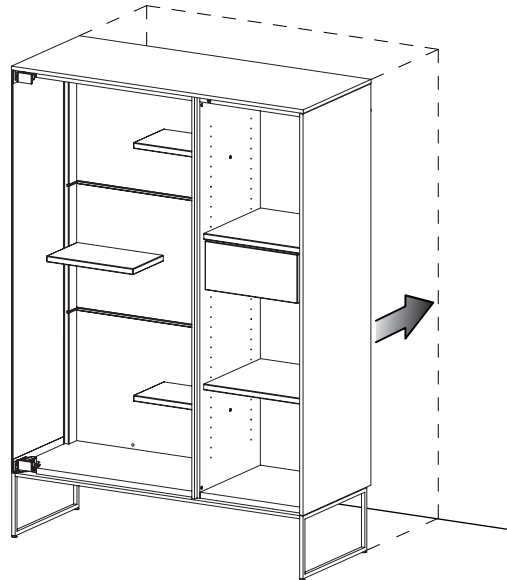
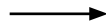
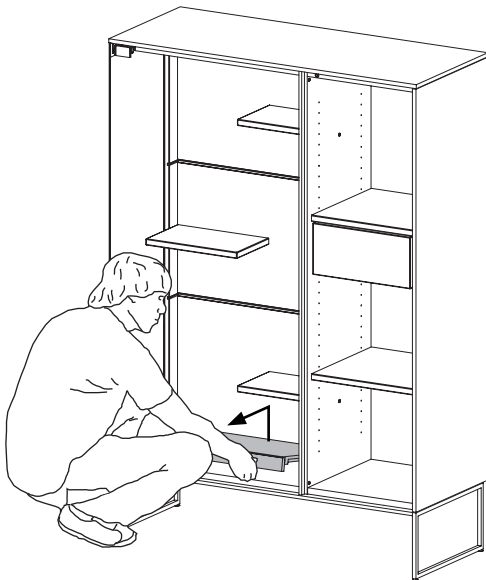



#### 4. Sekretär Ausrichten

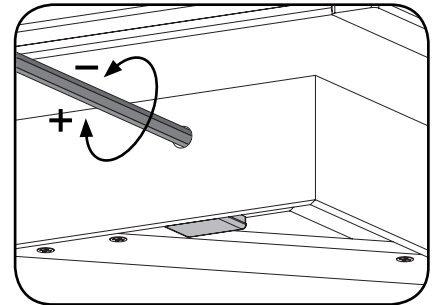
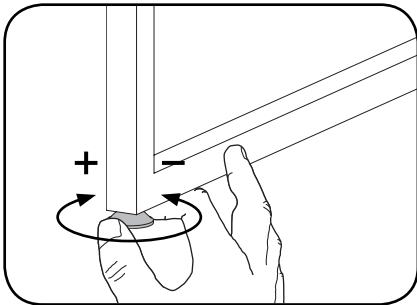
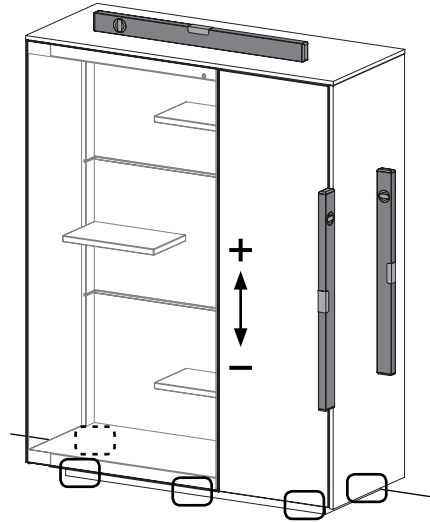
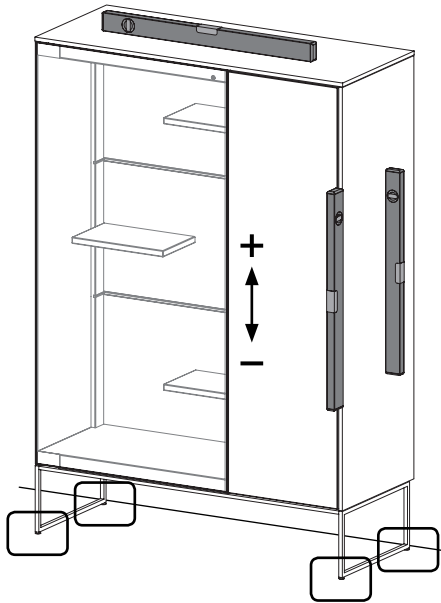

#### 5. Kippsicherung montieren

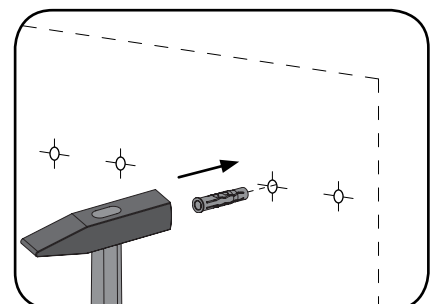
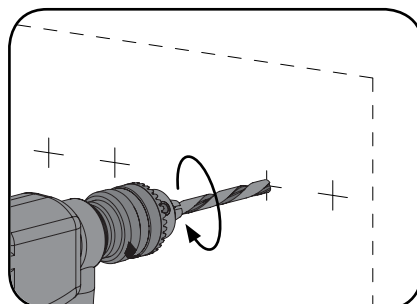
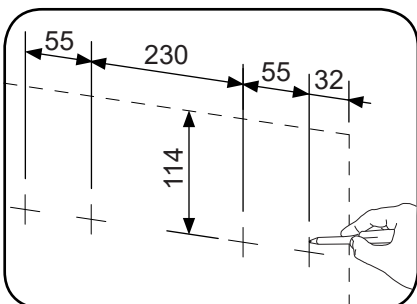
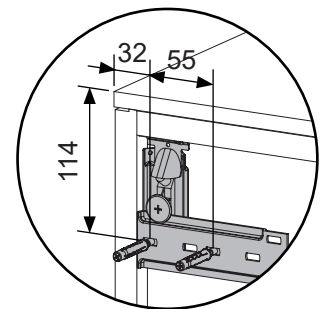
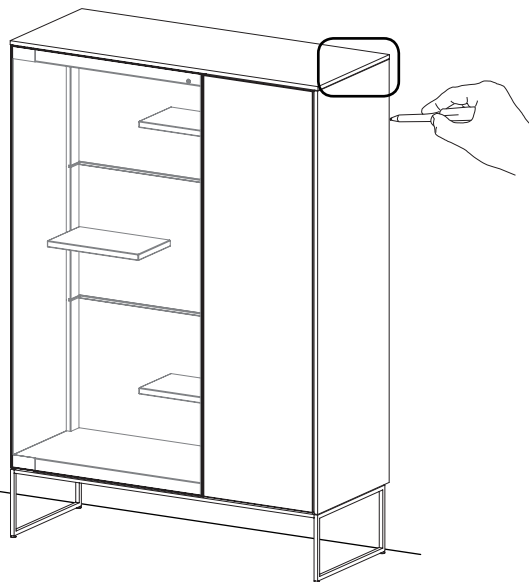
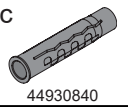

Alle Maße in Millimeter

## 6. Kippsicherung montieren

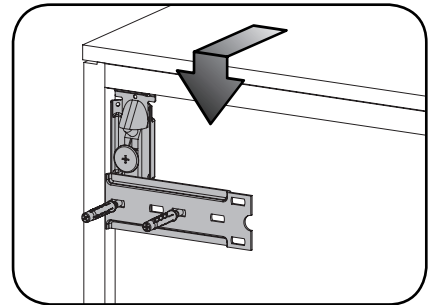
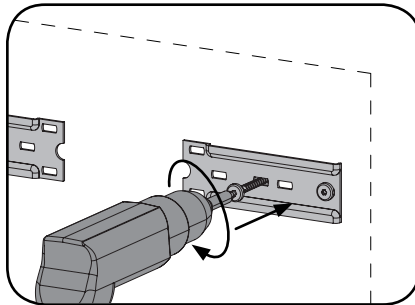
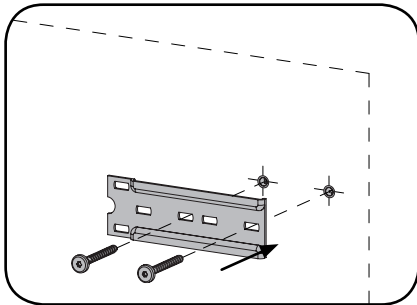
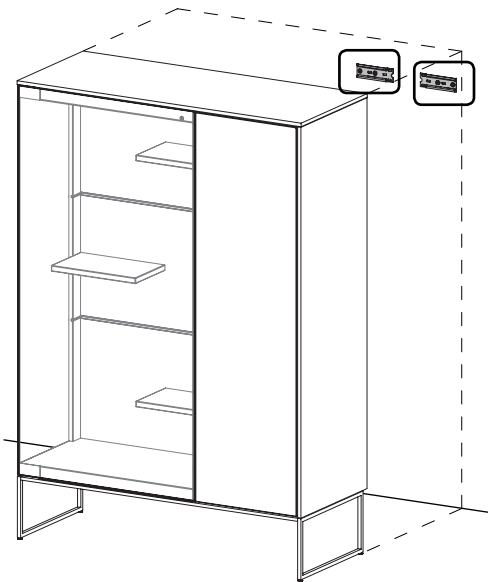
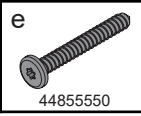
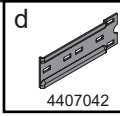

## 7. Kippsicherung einstellen

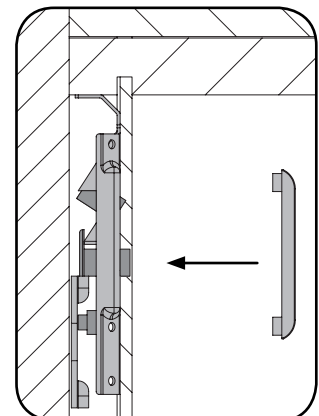
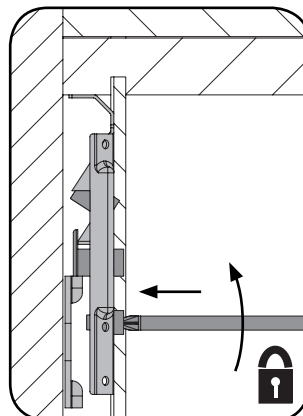
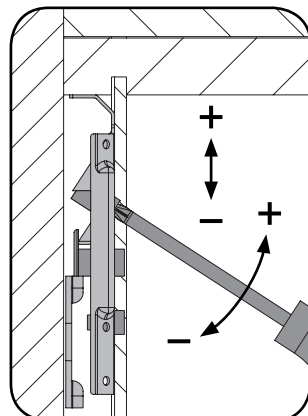
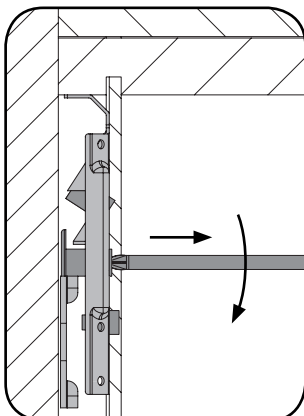
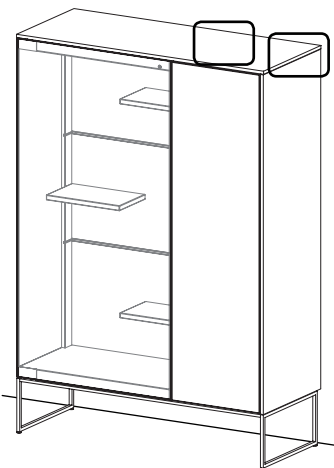
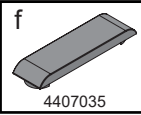

## 8. Türmontage

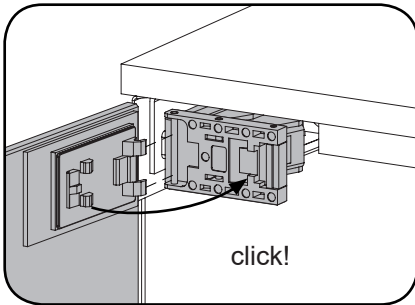
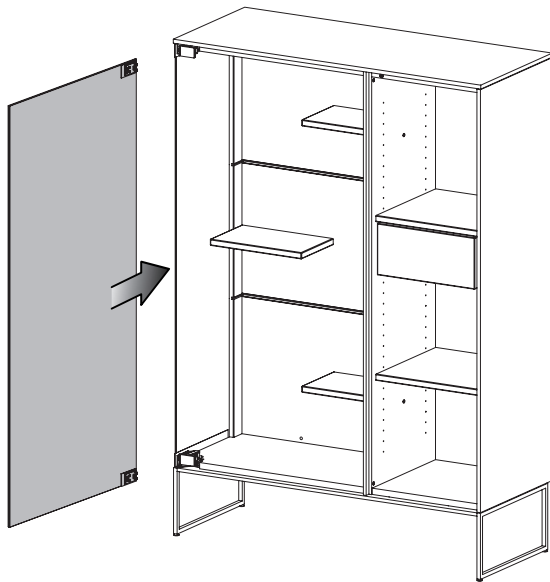

## 9. Türeinrichtung

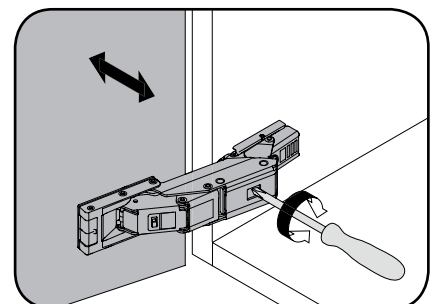
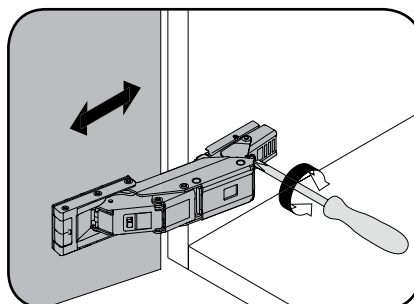
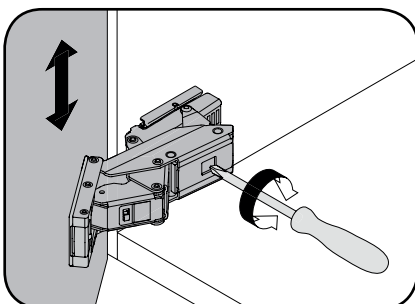
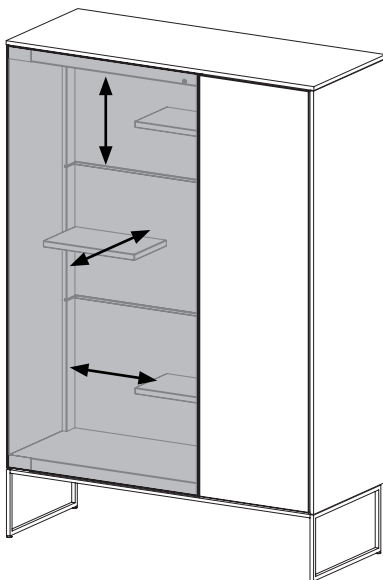

## 10. Ober- und Unterboden montieren

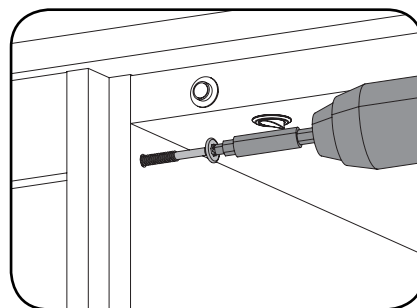
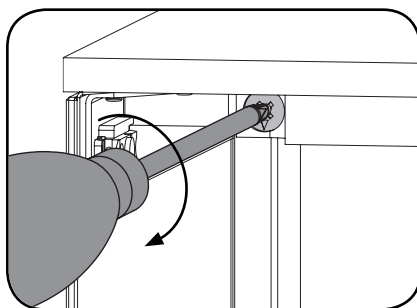
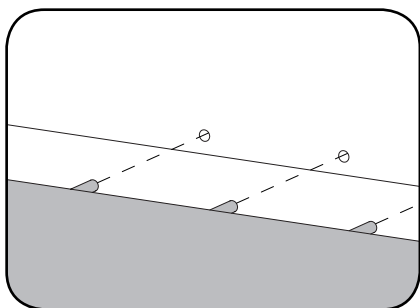
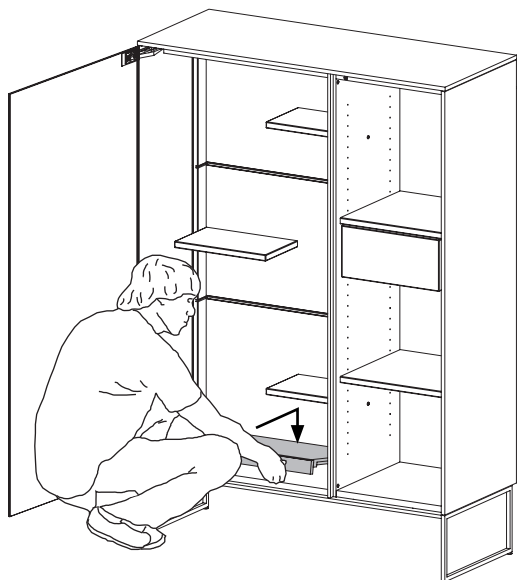

## 11. Glasfächer einlegen

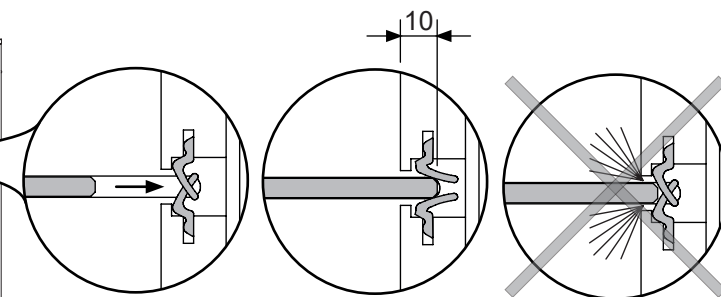
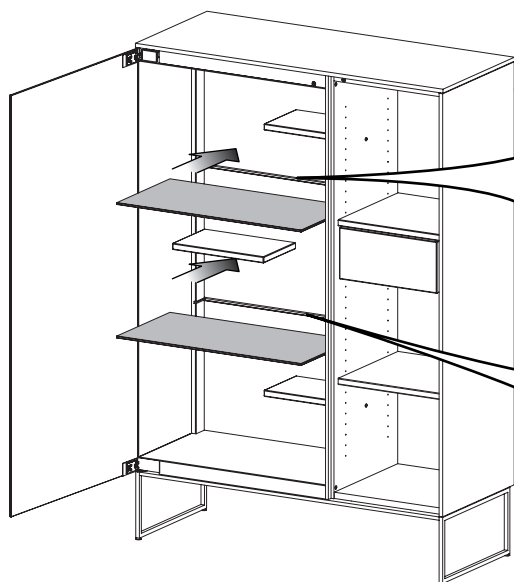

Achtung!

Vorderkante!

### **HINWEIS**

- Die Glasfächer mit Handschuhen einlegen um Kratzer und Verschmutzungen zu vermeiden

Alle Maße in Millimeter

88480207A

## Le Salon

### Filigno Vitrine

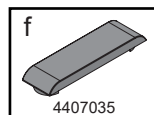
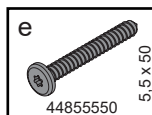
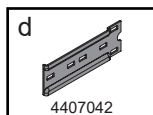
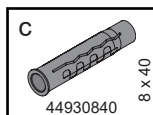
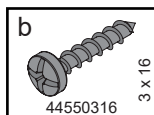
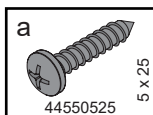
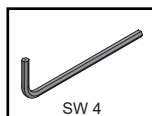
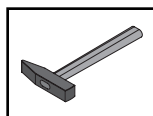
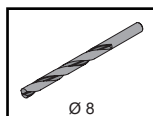
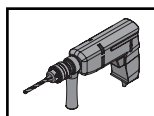
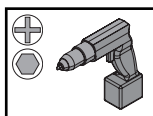
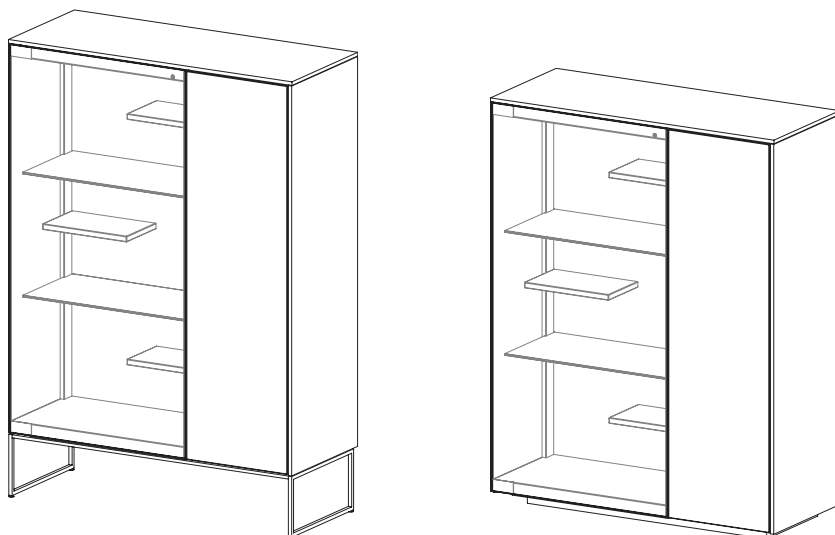

### ATTENTION

- Le matériau compris dans la livraison convient uniquement pour les murs en béton, en briques pleines ou perforées\*. Veuillez utiliser des chevilles spéciales pour tous les autres types de mur.
- Un spécialiste devra contrôler que le support soit adéquat et pour vérifier que les moyens de fixation soient en mesure de soutenir les forces exercées !
- En cas de non-respect de cette consigne de sécurité, TEAM 7 se dégage de toute responsabilité !
- Tous les travaux électriques doivent être effectués par un spécialiste approprié!
- Ne jamais ouvrir le bloc d'alimentation. Il y a danger de mort !
- Le nombre total de watts des spots ne doit pas être supérieur aux watts du transfo ou de la télécommande.
- Si un passe-câbles n'est pas prévu, en couper un avec une scie sauteuse.
- \* Ne pas utiliser de percussion pour les briques perforées !

### REMARQUE

- Les consignes d'entretien sont disponibles sur le site Internet TEAM 7 (entretien du bois naturel, du cuir, de l'étoffe, du Stricktex, de la pierre, du verre, métal, céramique du feutre et des plans de travail)
- Vous trouverez d'importantes caractéristiques des meubles en bois naturel TEAM 7 également dans le certificat de service et de qualité à l'adresse suivante : <http://www.team7.at/de/ueber-uns/service/service-und-guetepass>



## 1. Récapitulatif socle

Piètement métallique

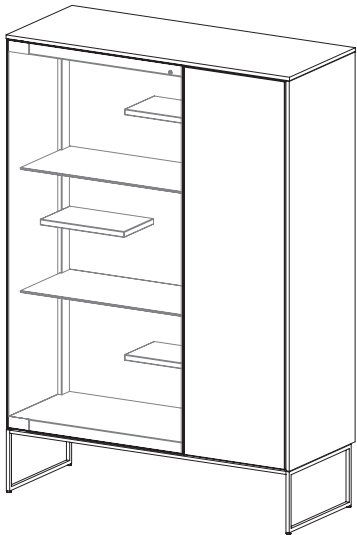

Socle en retrait

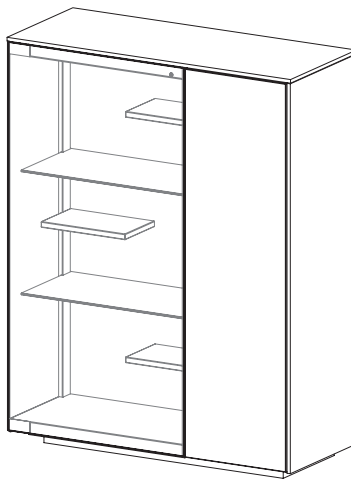

## 2. Monter piètement métallique

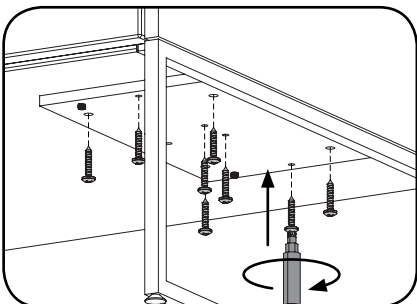
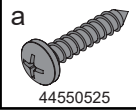
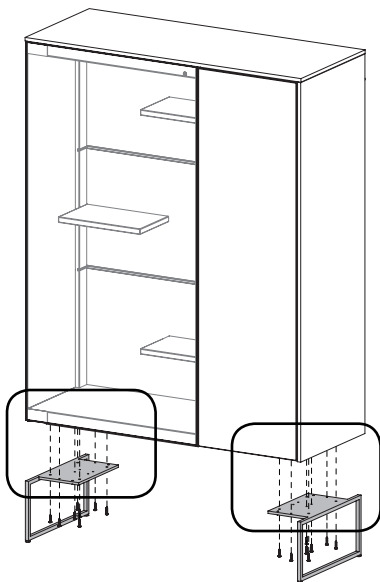

## 2. Monter piétement métallique

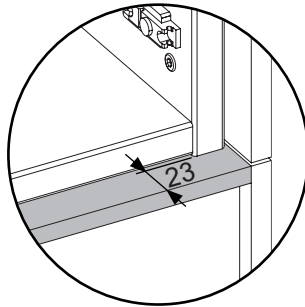
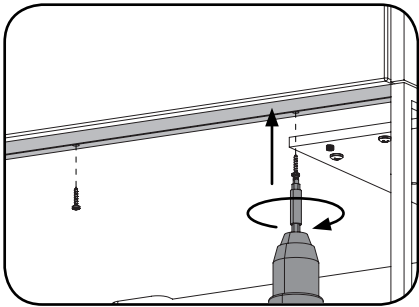
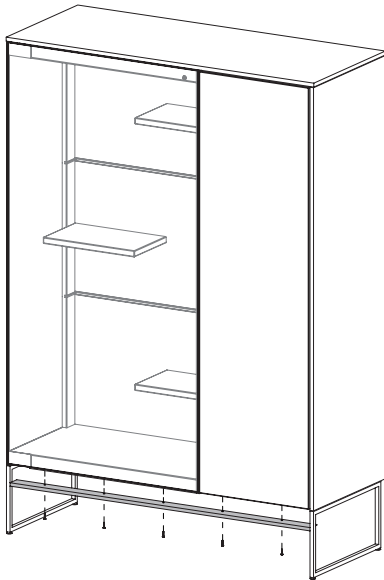
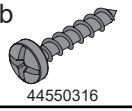

Toutes les mesures sont en millimètres!

## 3. Démontez le fond et le panneau supérieur

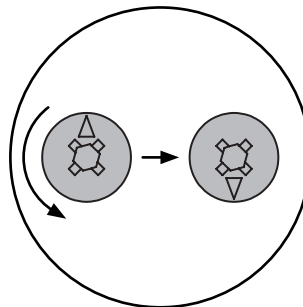
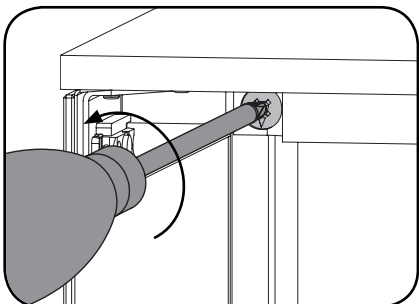
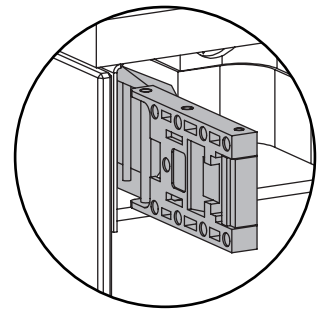
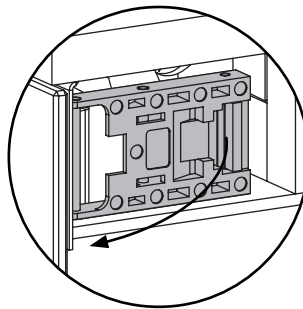

### 3.1 Démontez le panneau supérieur

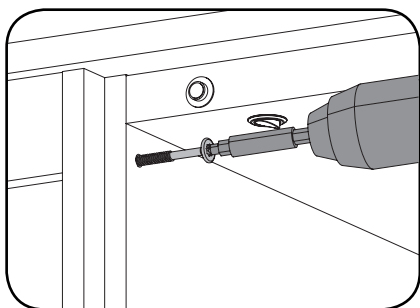
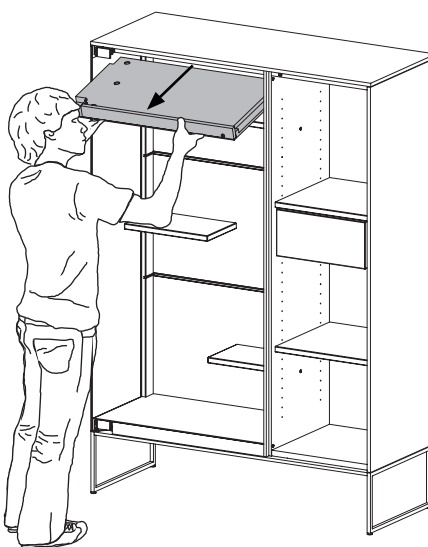

### 3.2 Démontez le fond

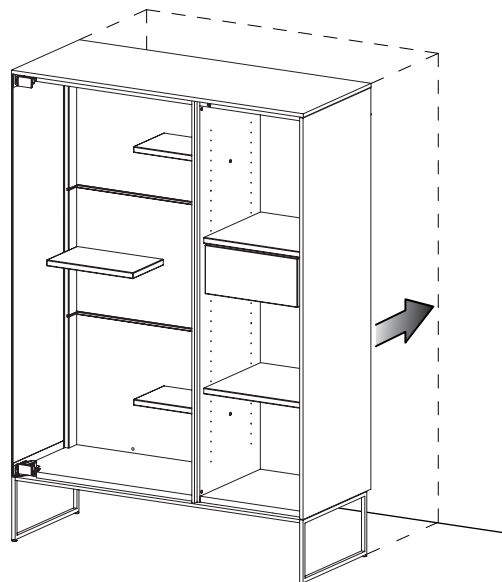



#### 4. Aligner le secrétaire

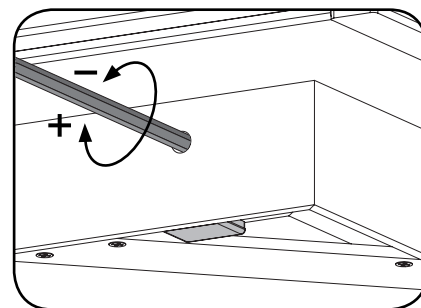
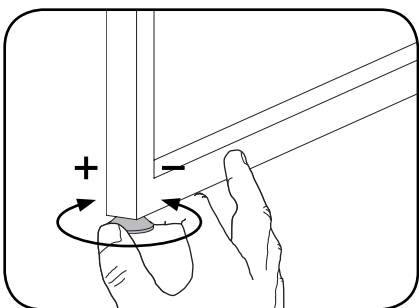
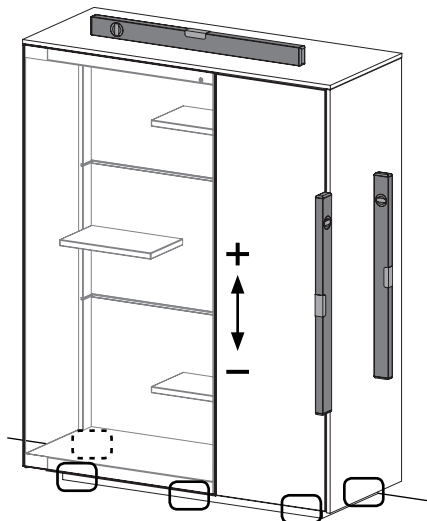
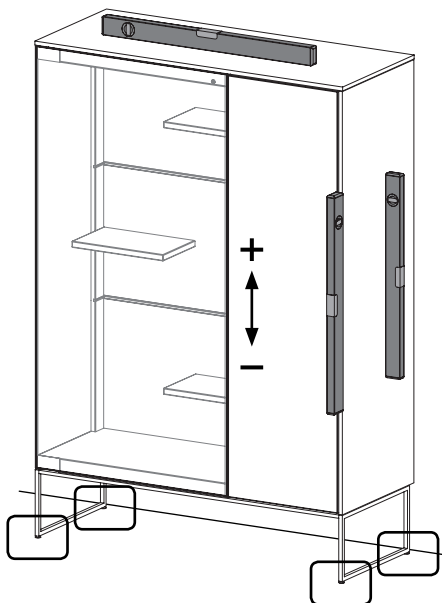

#### 5. Monter la sécurité anti-bascule

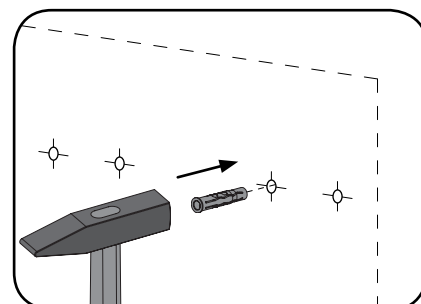
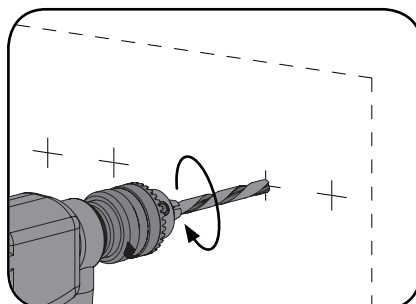
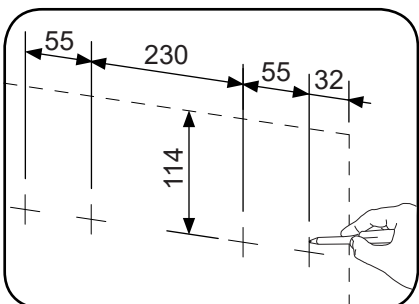
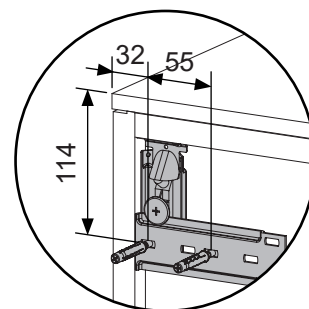
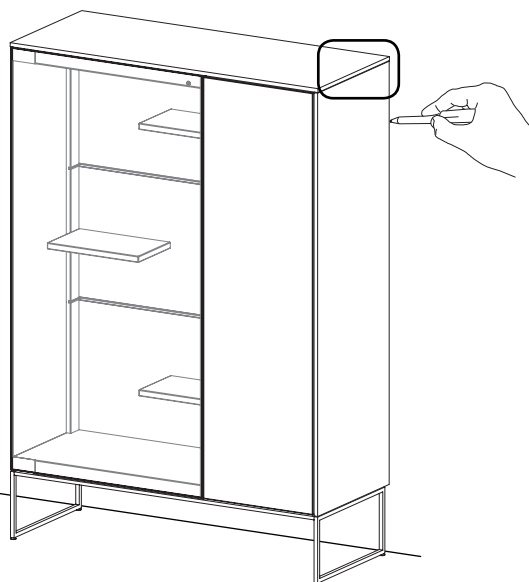
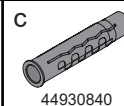

Toutes les mesures sont en millimètres!

## 6. Monter la sécurité anti-bascule

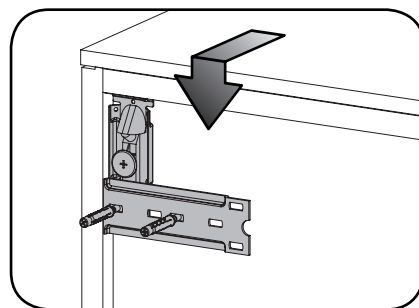
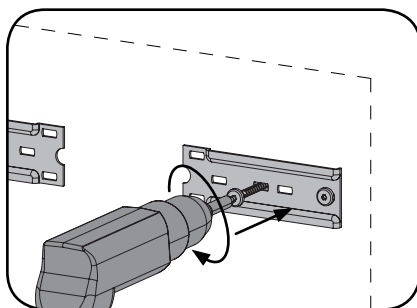
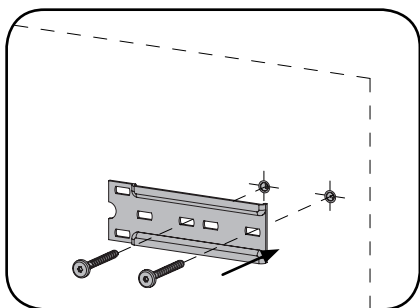
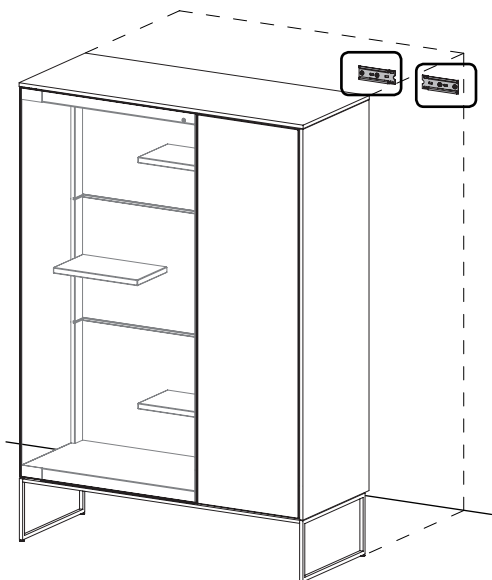
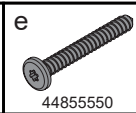
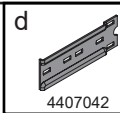

## 7. Ajuster la sécurité anti-bascule

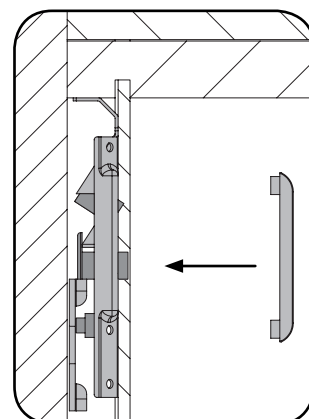
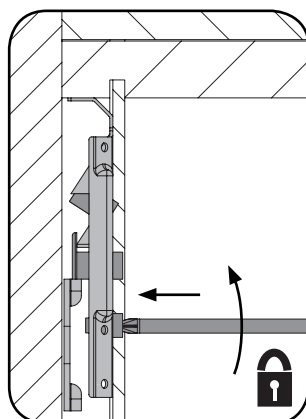
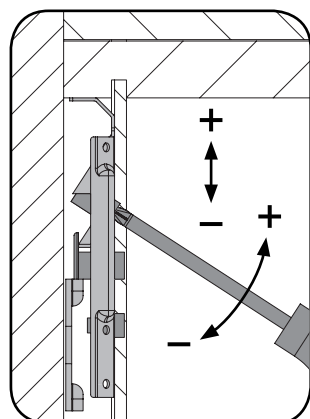
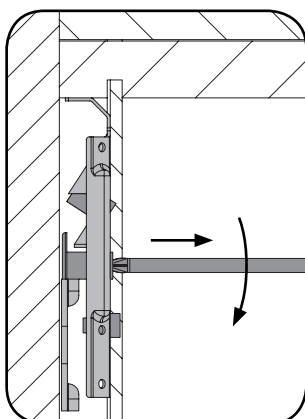
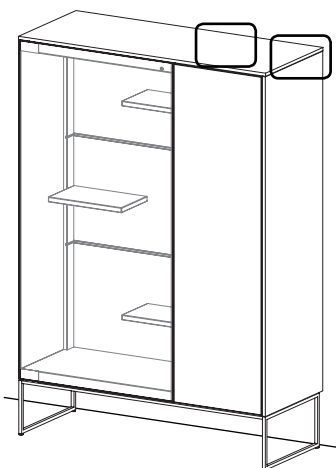
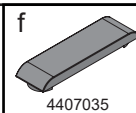

## 8. Montage de la porte

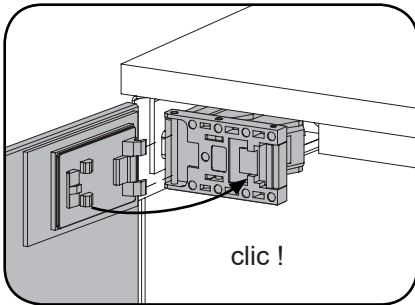
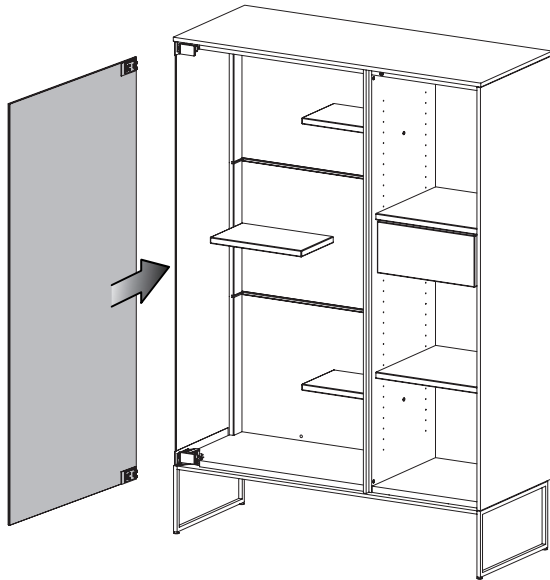

## 9. Réglage de la porte

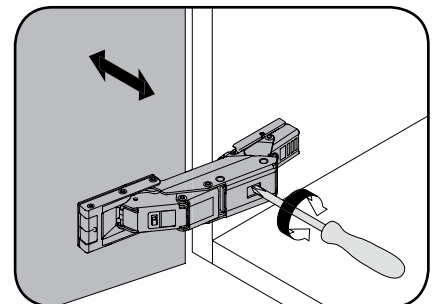
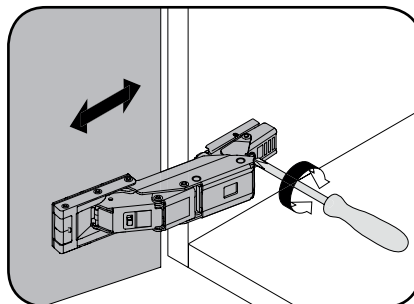
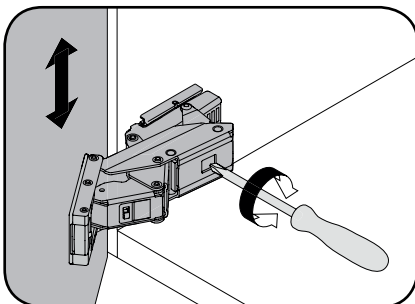
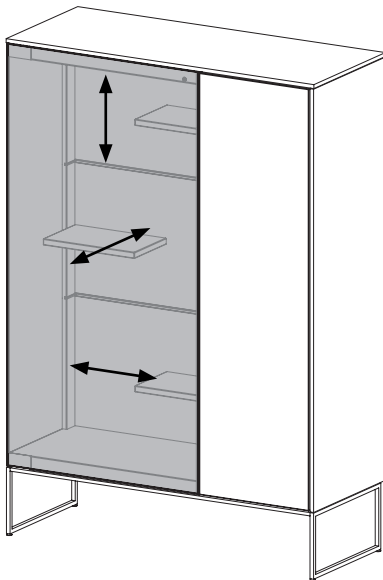

## 10. Monter le fond et le panneau supérieur

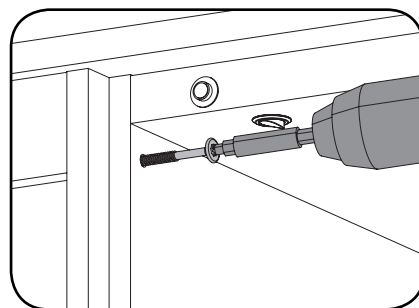
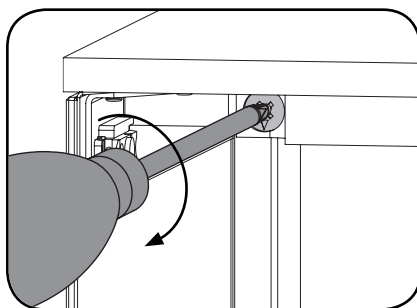
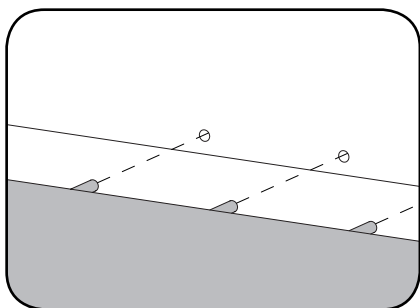
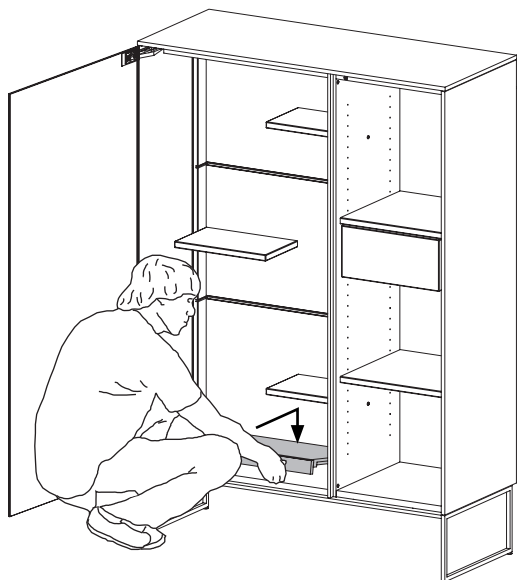

## 11. Monter les étagères en verre

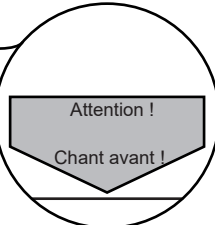
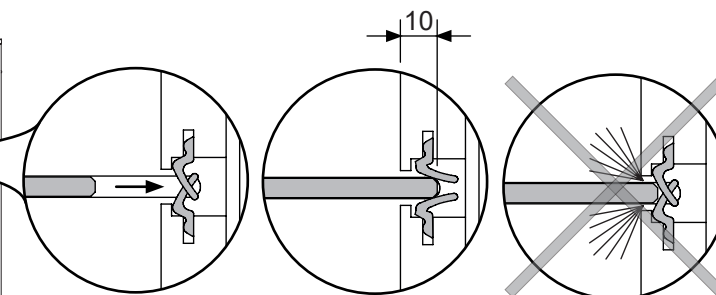
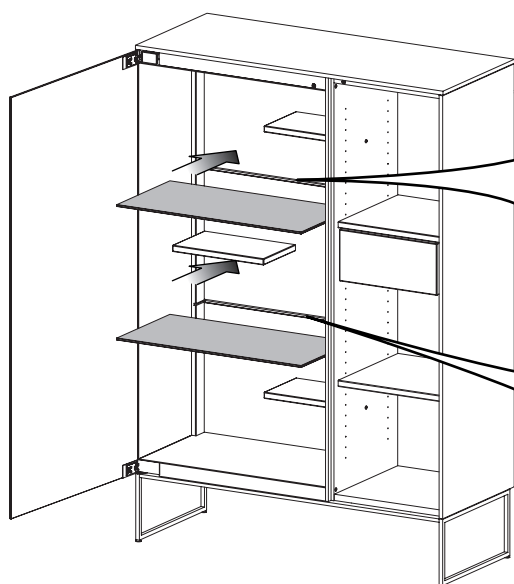

**REMARQUE**

- Afin de ne pas rayer ni de salir les étagères en verre, les monter uniquement en portant des gants.

Toutes les mesures sont en millimètres!

88480207A

## Soggiorno

## Vetrina Filigno

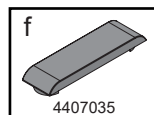
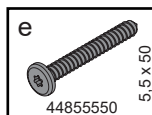
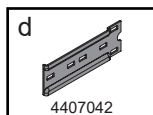
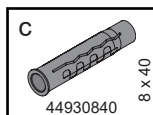
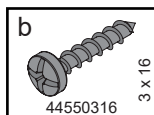
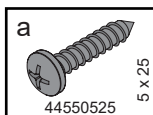
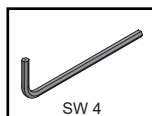
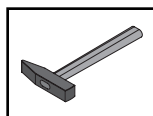
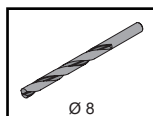
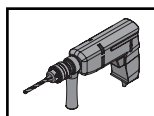
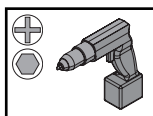
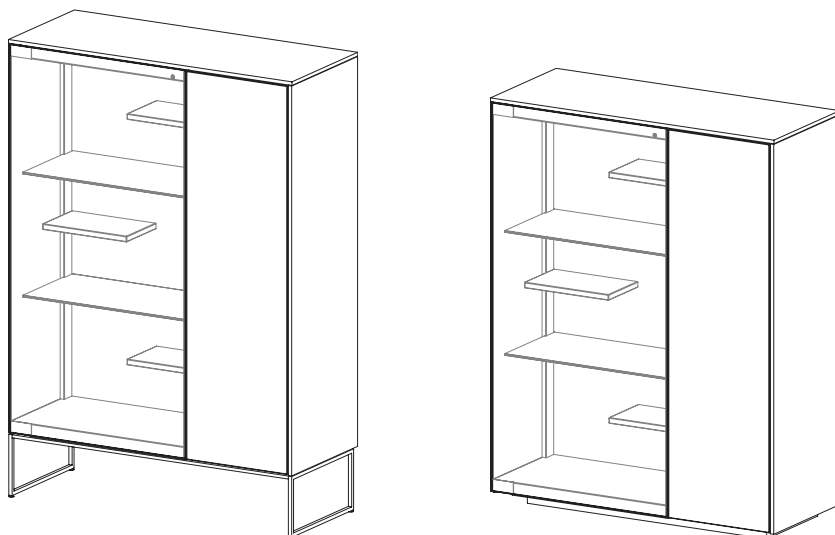
**⚠ ATTENZIONE**

- Il materiale accluso è idoneo per pareti in calcestruzzo, mattoni pieni e mattoni forati alti\*. Per altri tipi di parete, utilizzare tasselli speciali.
- Il tecnico deve controllare l'idoneità del sottofondo e che i mezzi usati per il fissaggio siano in grado di sopportare le forze generate!
- TEAM 7 non si assume alcuna responsabilità del prodotto in caso di mancato rispetto di questa avvertenza!
- Tutti i lavori elettrici devono essere eseguiti da uno specialista adatto!
- Non aprire mai un alimentatore. Pericolo di morte!
- La somma dei watt dei faretto non deve essere superiore alla potenza in watt del trasformatore o dell'unità radio.
- Se è previsto un foro passacavi, praticarlo con sega a gattuccio  
\* per i mattoni forati, non usare la percussione!

**⚠ AVVERTENZA**

- Per le istruzioni di manutenzione (cura di pannelli in legno naturale, pelle, stoffa, Stricktex, pietra, vetro, Metallo, ceramica feltro e piani di lavoro) consultare il sito web di TEAM 7.
- Troverete importanti caratteristiche dei mobili in legno naturale TEAM 7 anche nel nostro pass assistenza e qualità qui:

<http://www.team7.at/de/ueber-uns/service/service-und-guetepass>



## 1. Prospetto zoccolo

Telaio di supporto in metallo

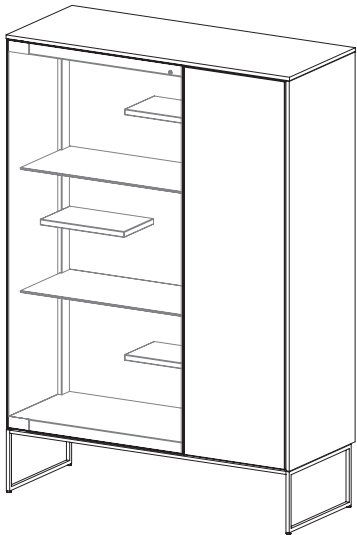

Zoccolo rientrante

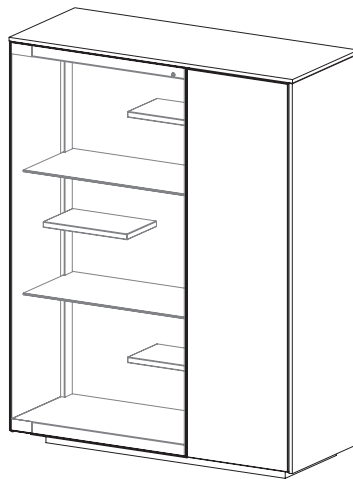

## 2. Montare il telaio di supporto in metallo

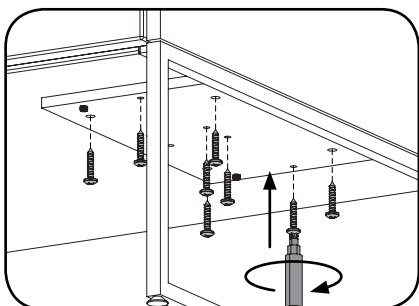
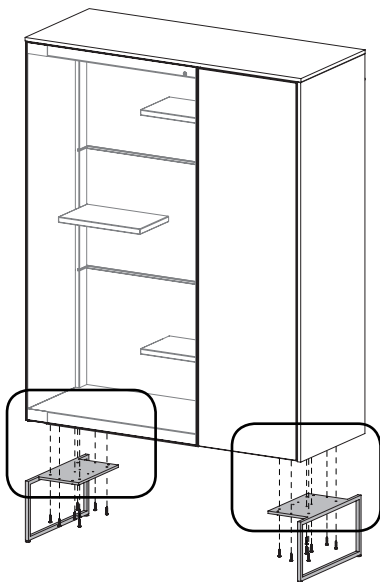

## 2. Montare il telaio di supporto in metallo

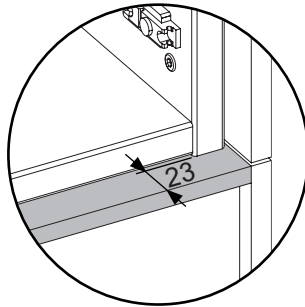
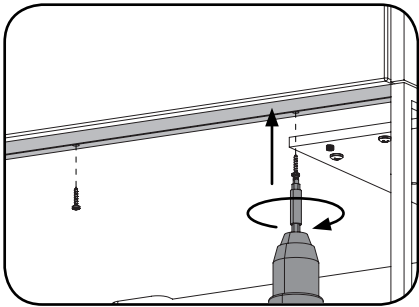
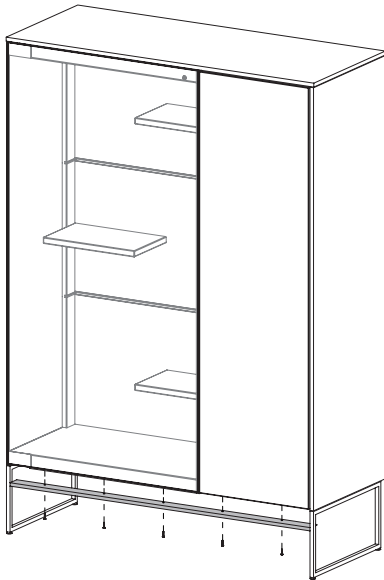
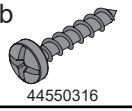

Tutte le misure sono in millimetri!

## 3. Smontare ripiano superiore e inferiore

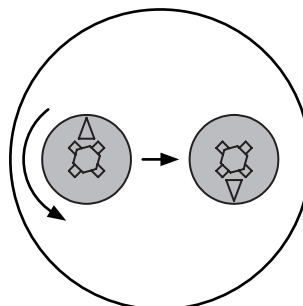
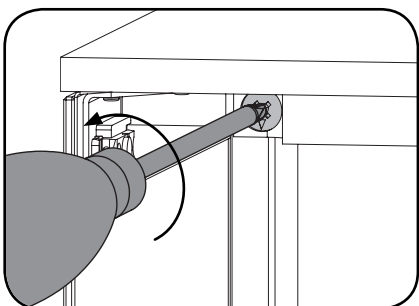
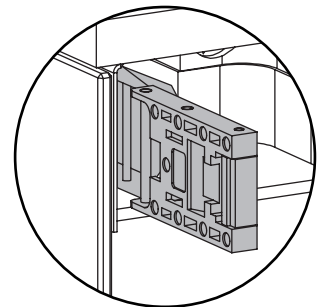
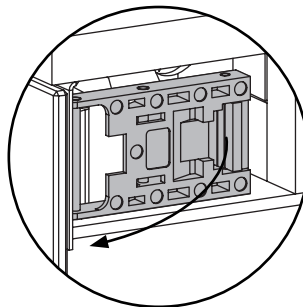

### 3.1 Smontare ripiano superiore

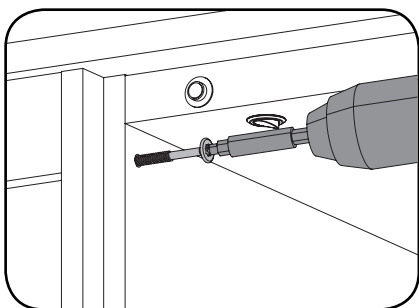
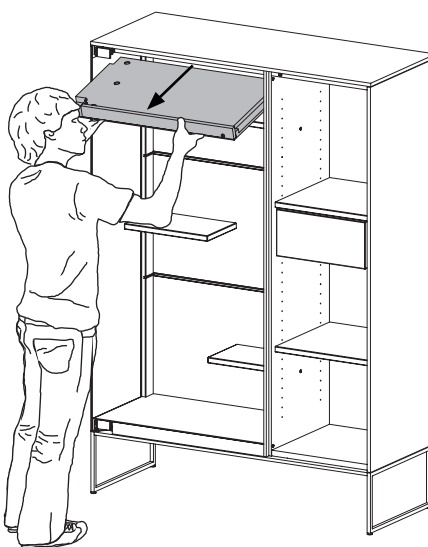

### 3.2 Smontare il ripiano inferiore

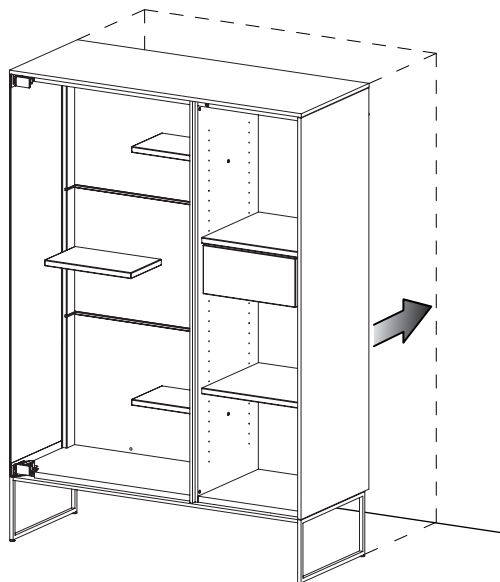
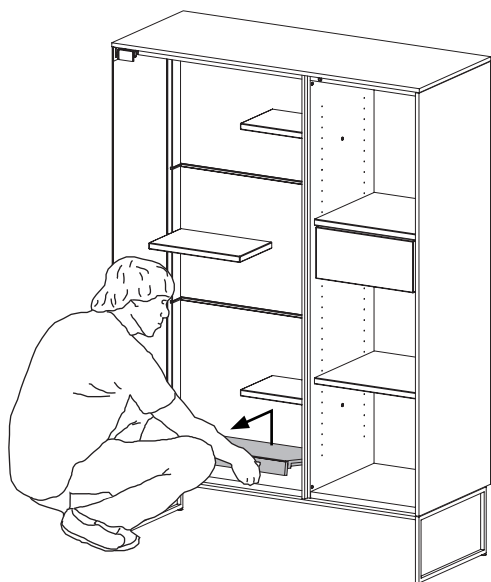



**4. Allineare il secretaire**

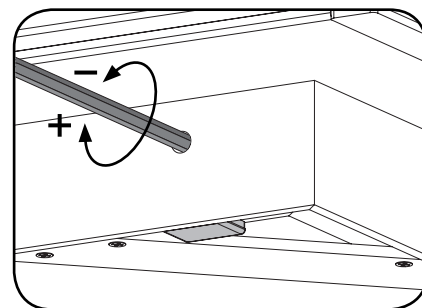
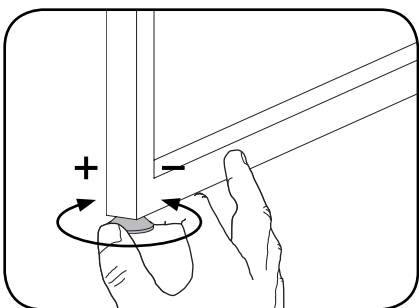
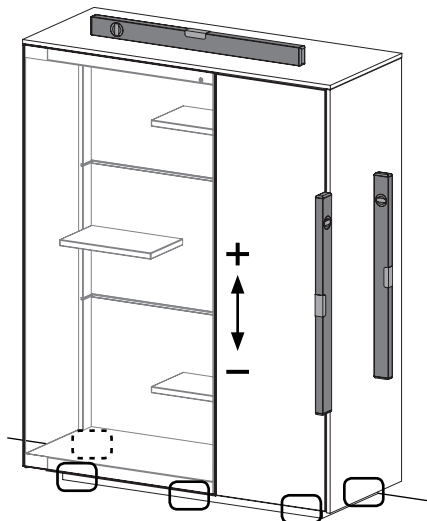
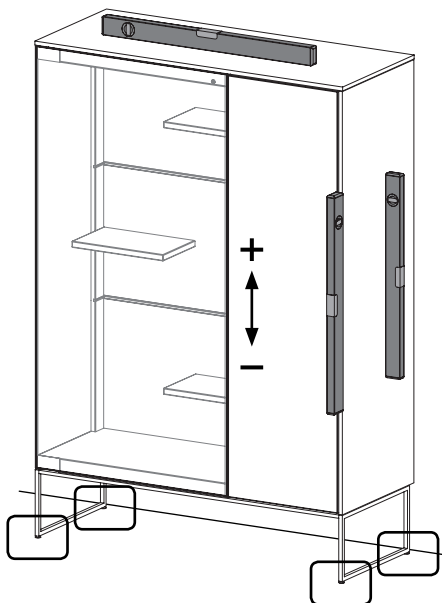

**5. Montare il dispositivo antiribaltamento**

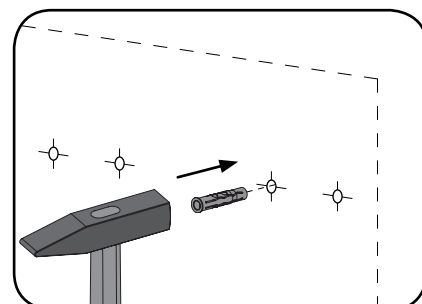
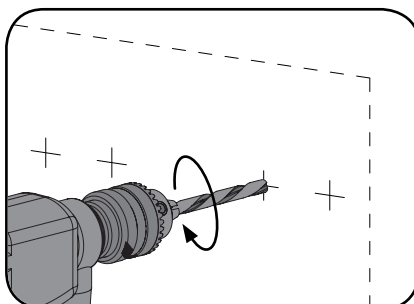
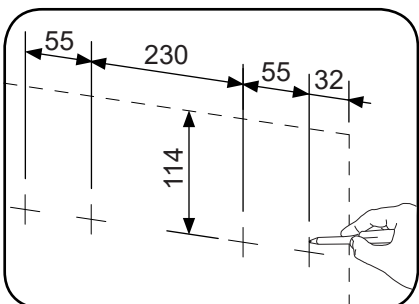
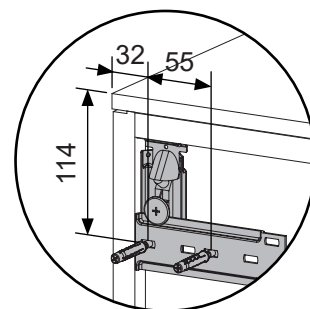
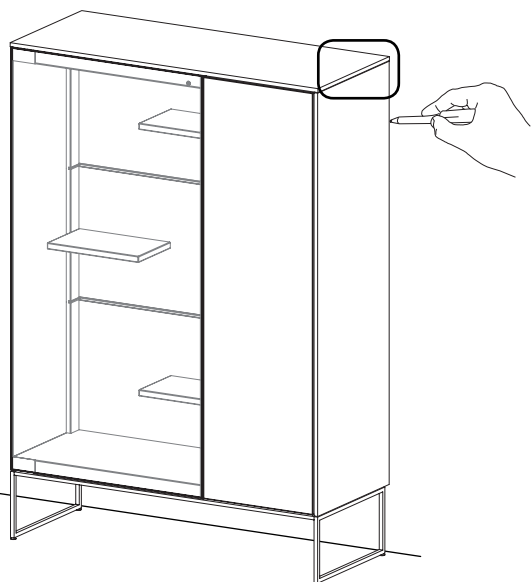
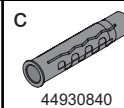

**Tutte le misure sono in millimetri!**

## 6. Montare il dispositivo antiribaltamento

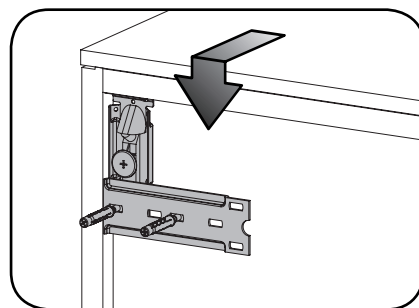
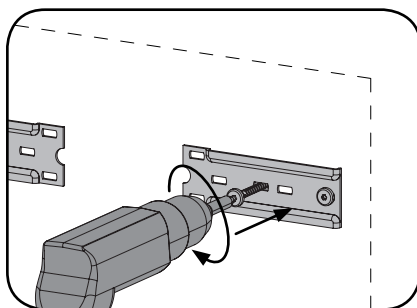
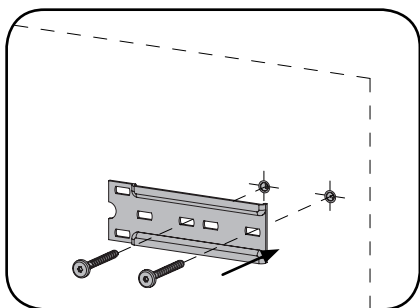
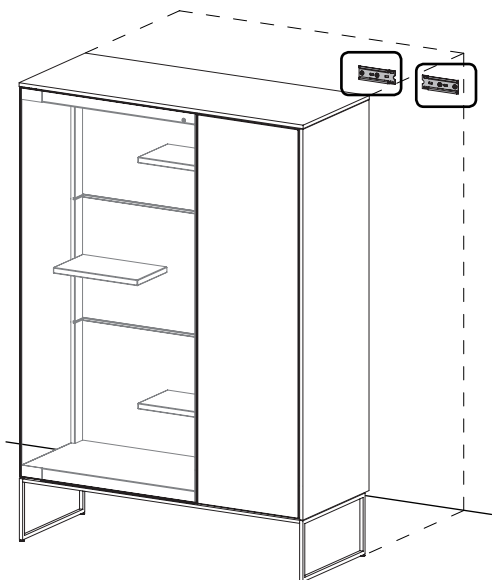
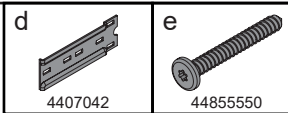

## 7. Regolare il dispositivo antiribaltamento

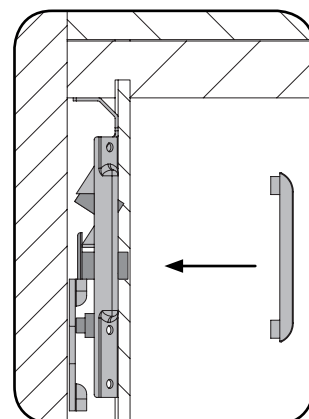
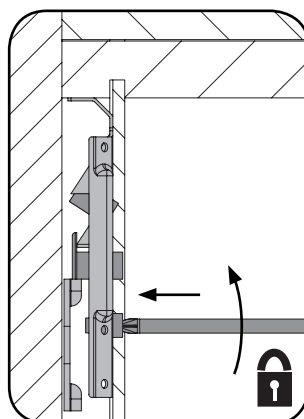
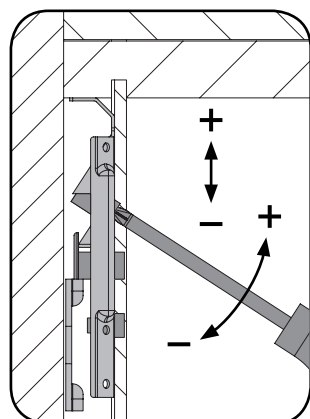
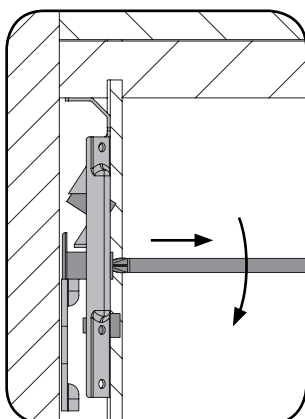
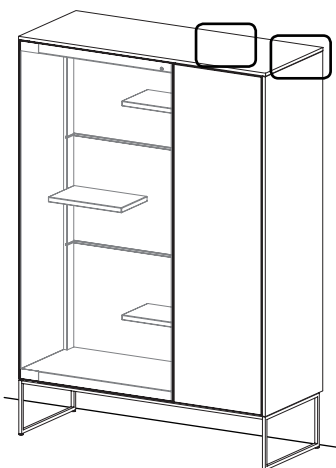
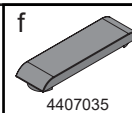

## 8. Montaggio anta

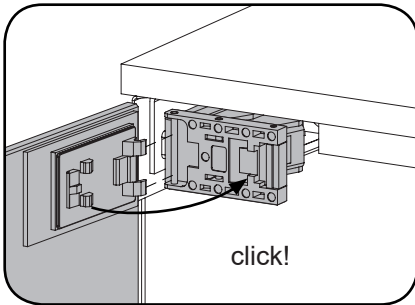
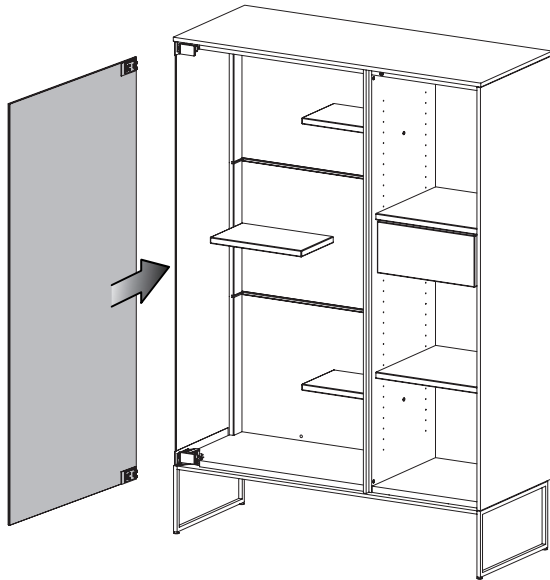

## 9. Regolazione anta

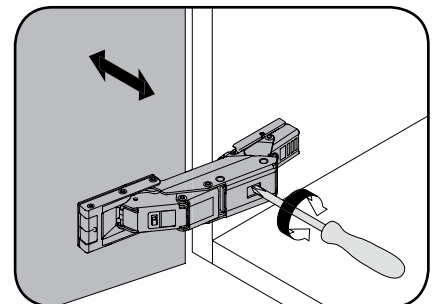
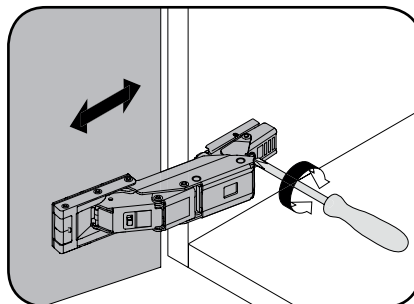
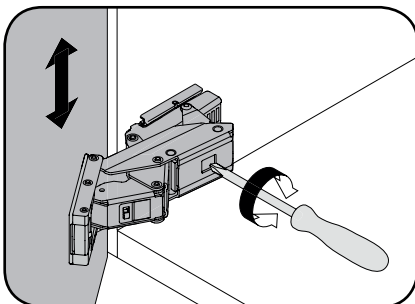
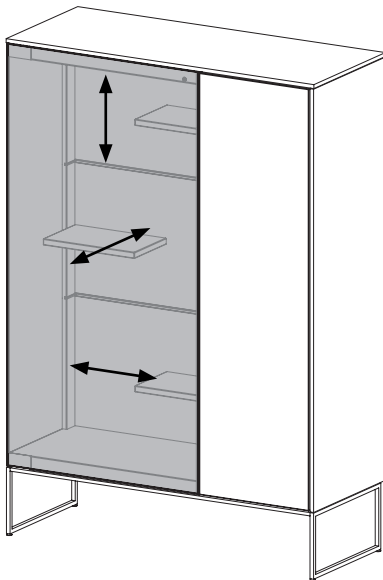

## 10. Montare ripiano superiore e inferiore

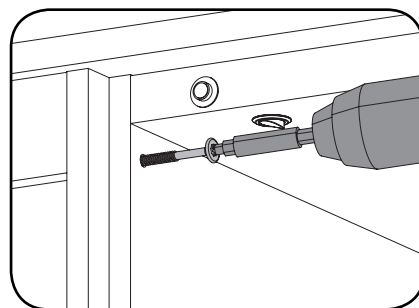
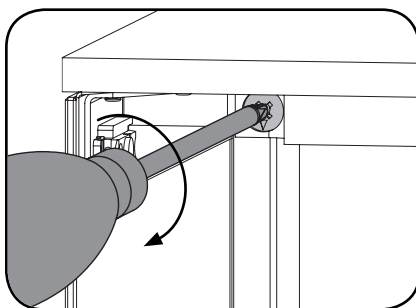
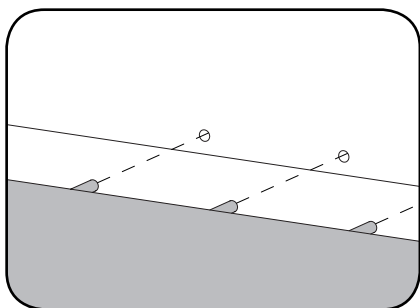
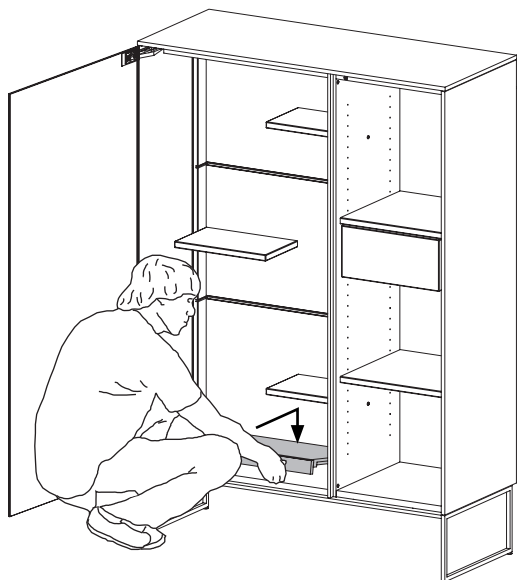

## 11. Inserire i ripiani in vetro

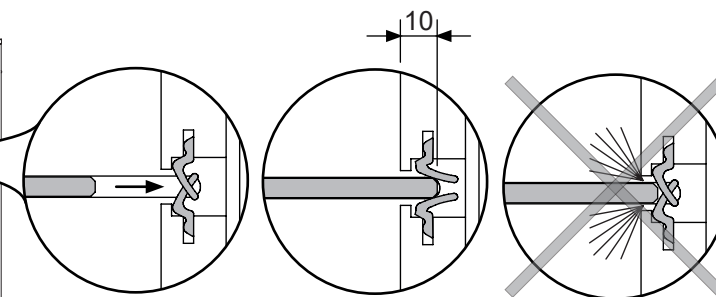
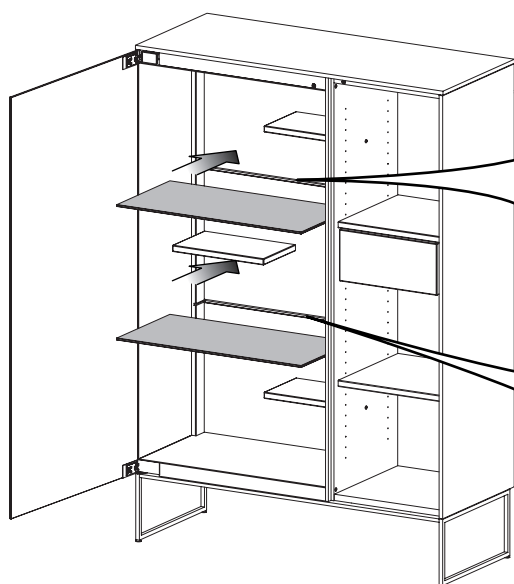

ATTENZIONE!

Spigolo anteriore!

### **AVVERTENZA**

- Le mensole di vetro devono essere montate indossando i guanti in modo da evitare di rigarle o sporcarle.

Tutte le misure sono in millimetri!

88480207A

## Living

### Filigno glass cabinet

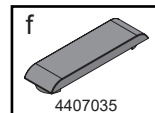
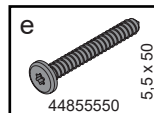
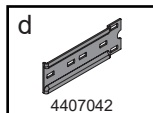
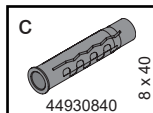
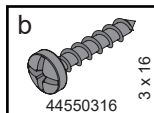
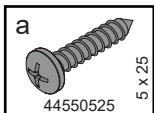
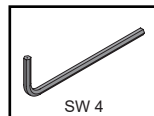
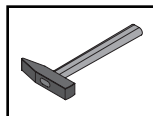
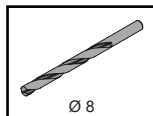
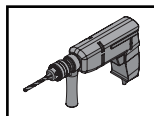
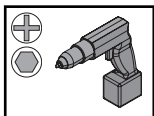
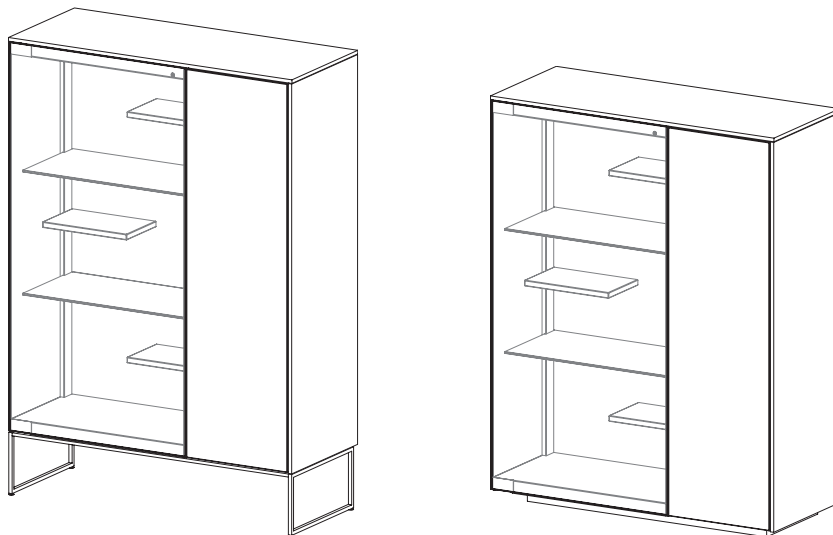

### ⚠ IMPORTANT

- The enclosed material can only be used for concrete walls, solid brick walls and walls made from vertically perforated bricks\*. Special dowels must be used for all other wall types.
  - The suitability of the substrate must be examined by an expert to establish whether the mounting hardware can withstand the applied forces!
  - TEAM 7 cannot accept any liability for the product if this safety instruction is disregarded!
  - All electrical work must be carried out by a suitable specialist!
  - Never open a power pack. Danger of fatal electric shocks!
  - The total of the watt number of spots must not exceed the watt performance of the transformer or the radio unit.
  - Cut an opening with a keyhole saw if a cable opening has not been provided.
- \* Work without impact when drilling into vertically perforated bricks!

### ⚠ NOTICE

- Care instructions (care of natural wood, leather, fabric, Stricktex, stone, glass, felt, metal, ceramics and worktops) can be found on the TEAM 7 website.
- Major typical product properties of natural wood furniture from TEAM 7 can also be found in our service and quality certificate on:

<http://www.team7.at/de/ueber-uns/service/service-und-guetepass>



## 1. Overview of top and bottom frames

Metal framed base

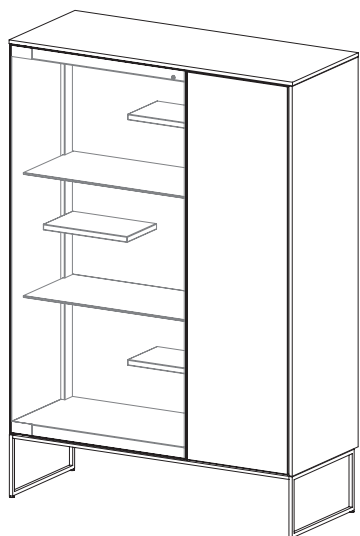

Recessed plinth

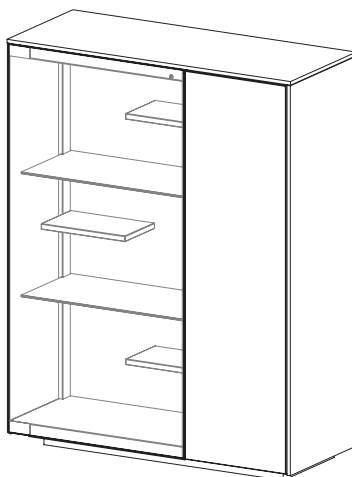

## 2. Install metal framed base

a



44550525

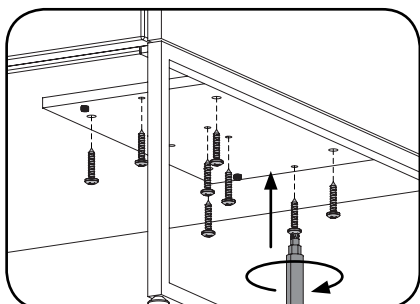
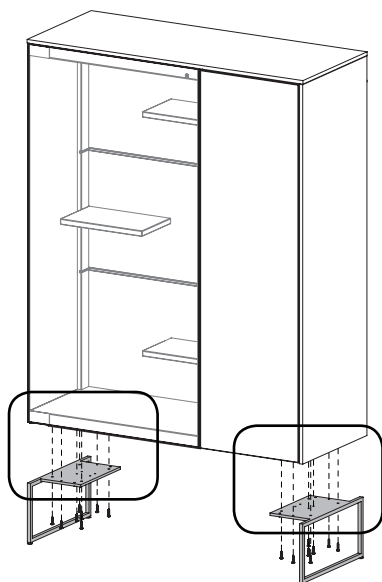

## 2. Install metal framed base

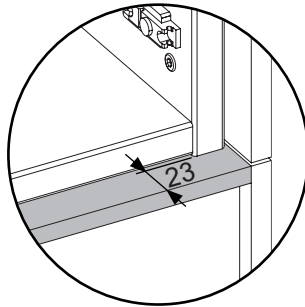
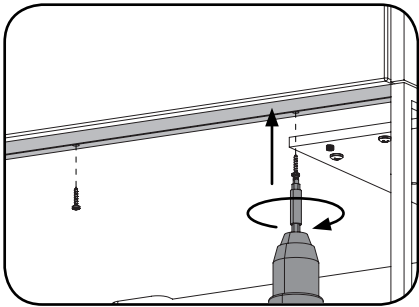
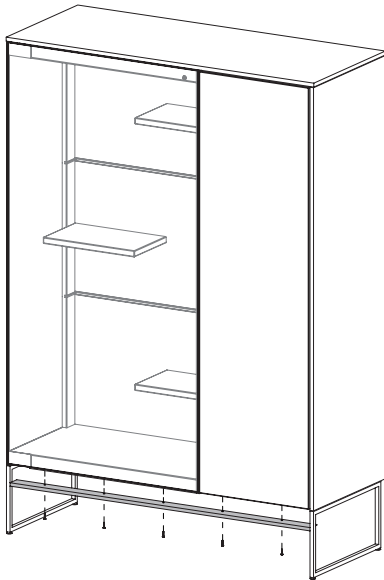
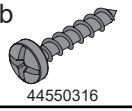

All dimensions in millimeters

## 3. Remove top and bottom panel

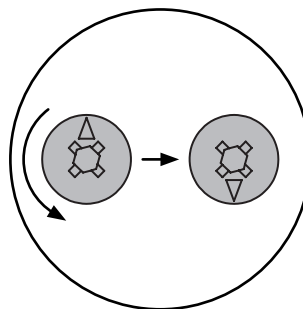
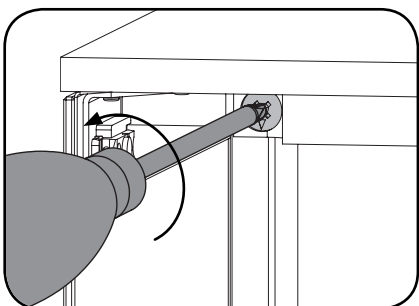
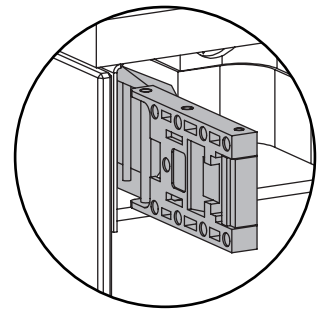
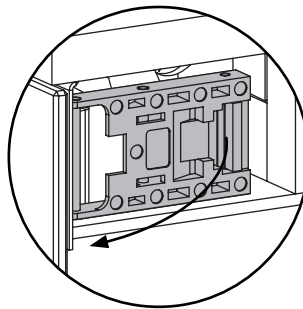

### 3.1 Remove top panel

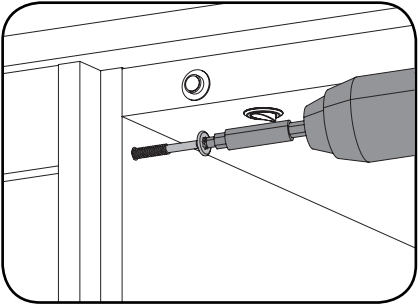
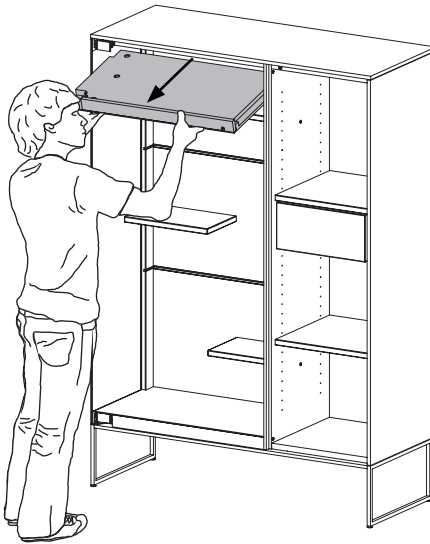

### 3.2 Remove bottom panel

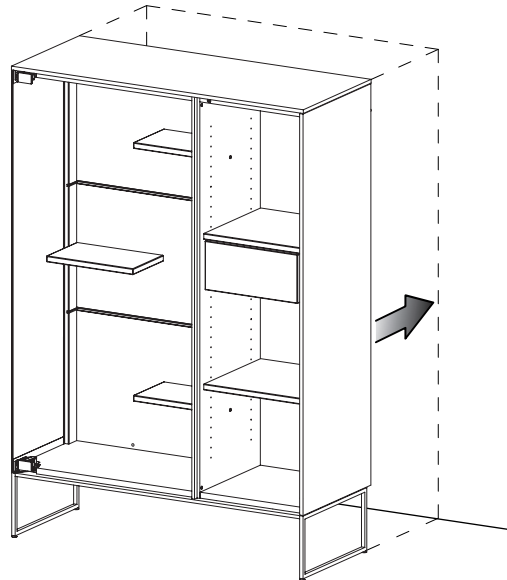
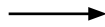
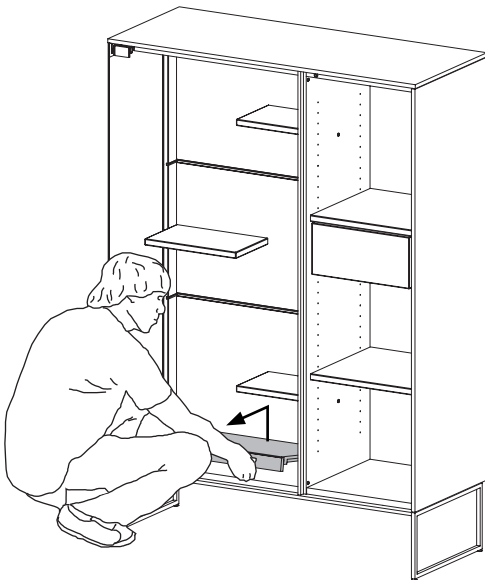



#### 4. Align writing desk

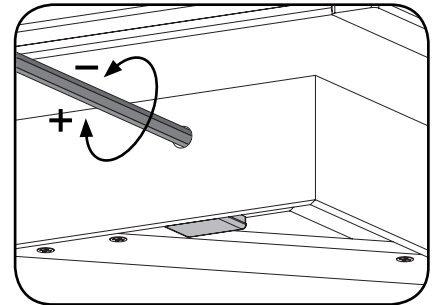
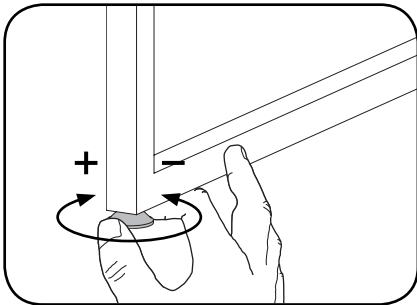
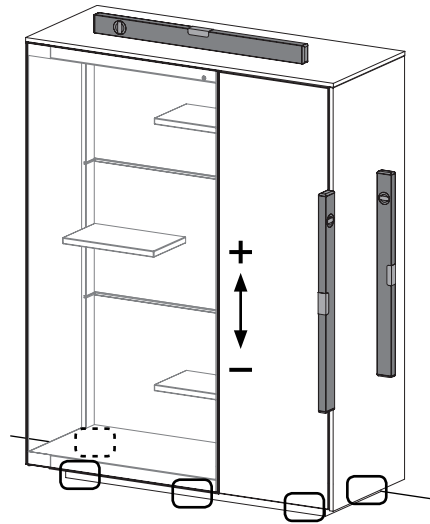
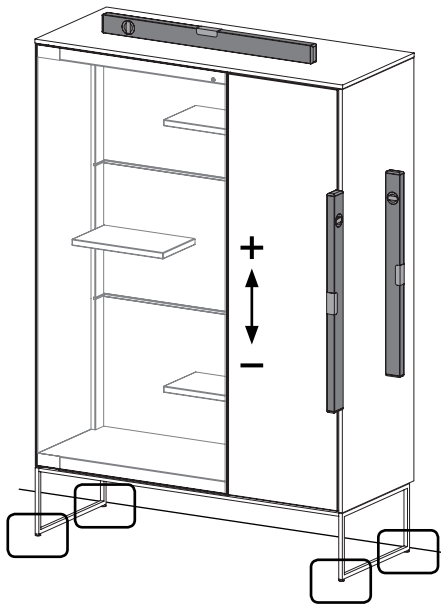

#### 5. Mount the anti-tilt guard

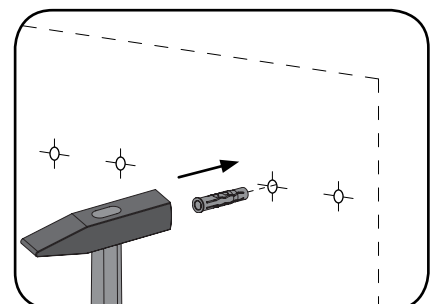
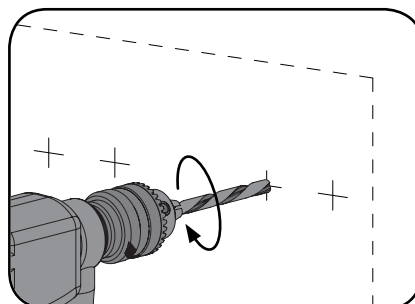
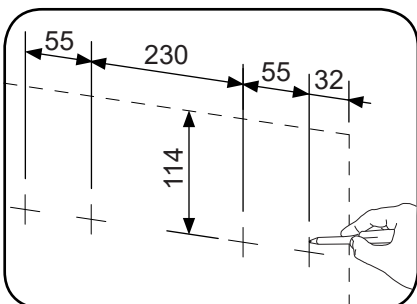
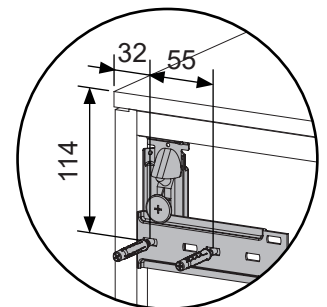
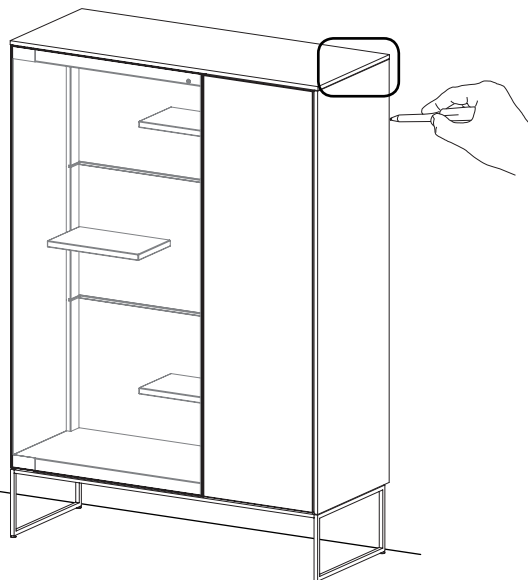
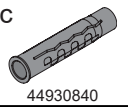

All dimensions in millimeters

## 6. Mount the anti-tilt guard

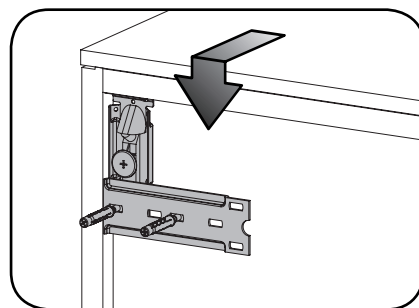
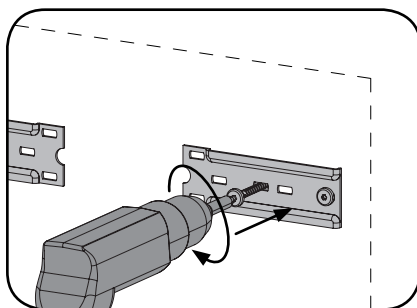
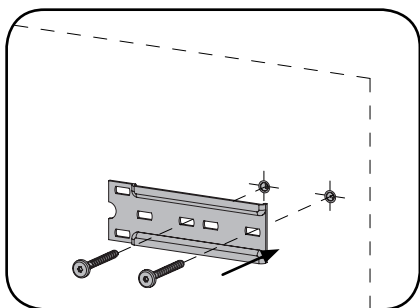
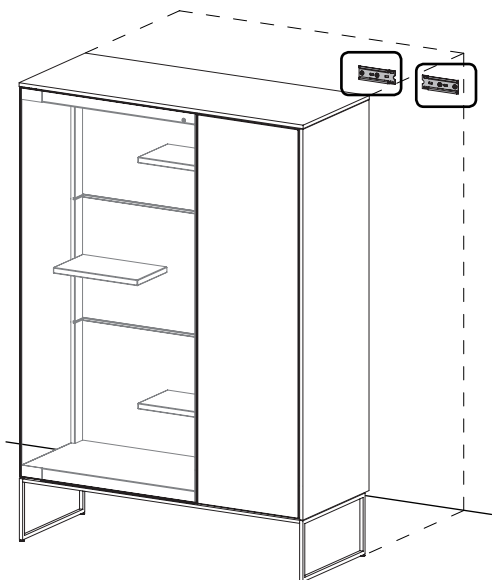
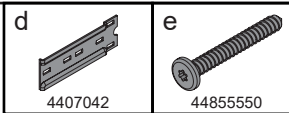

## 7. Adjust anti-tilt guard

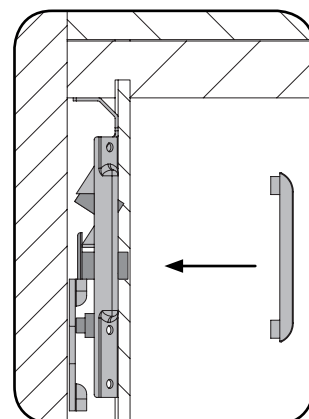
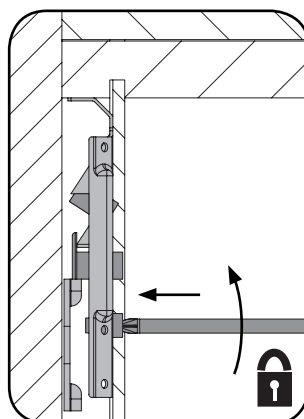
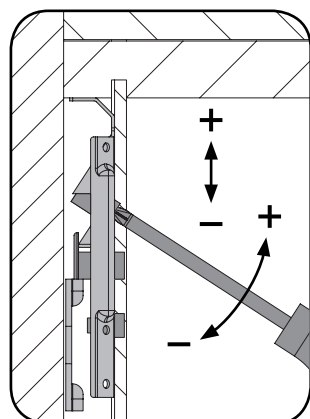
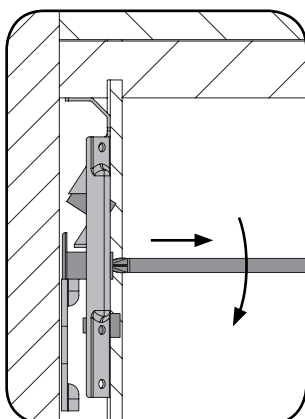
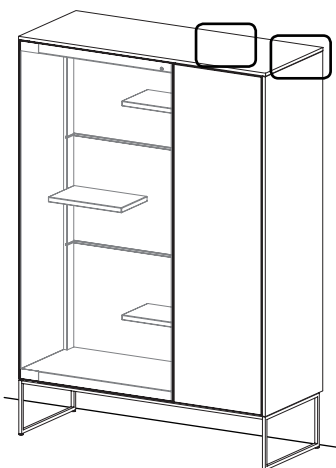
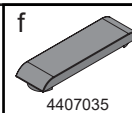

## 8. Door installation

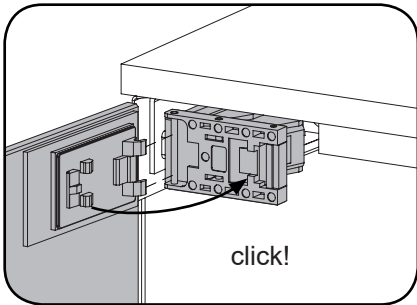
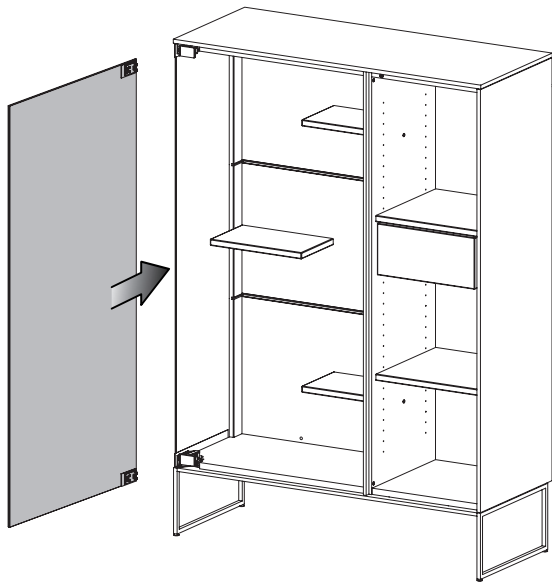

## 9. Door adjustment

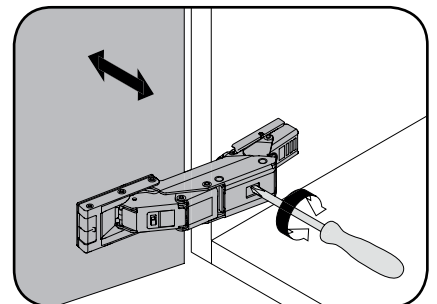
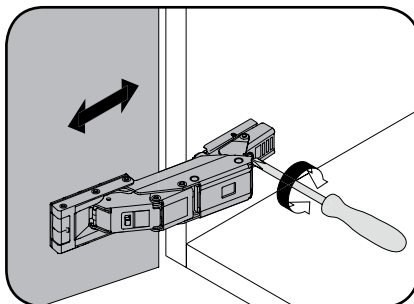
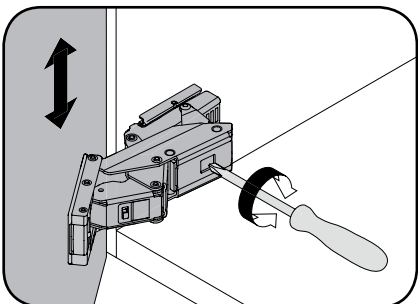
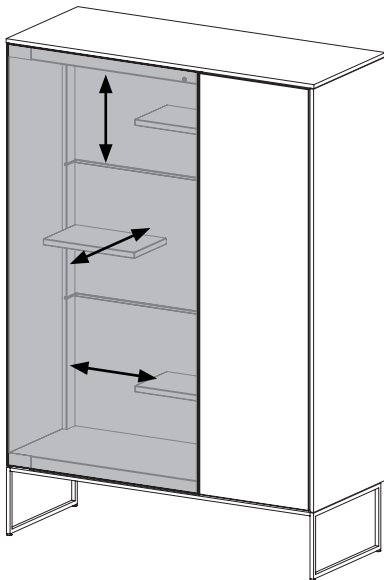

## 10. Install top and bottom panel

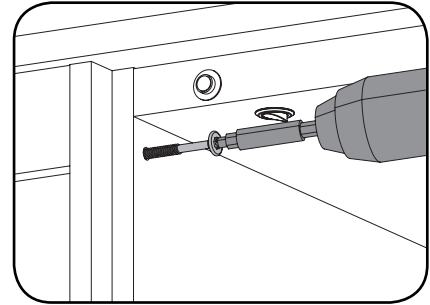
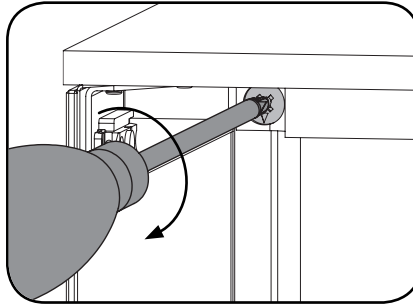
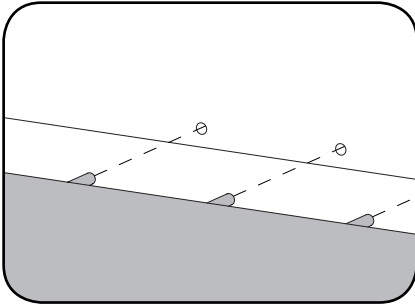
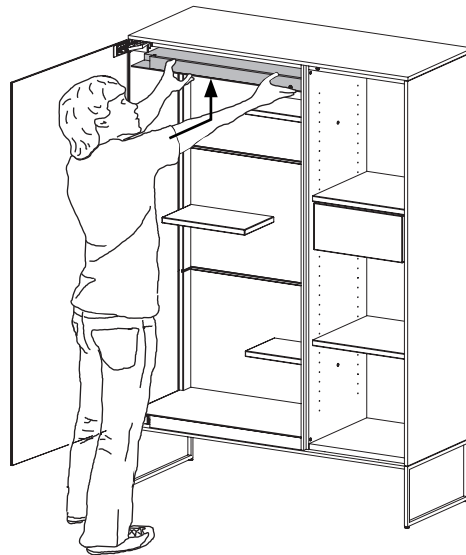
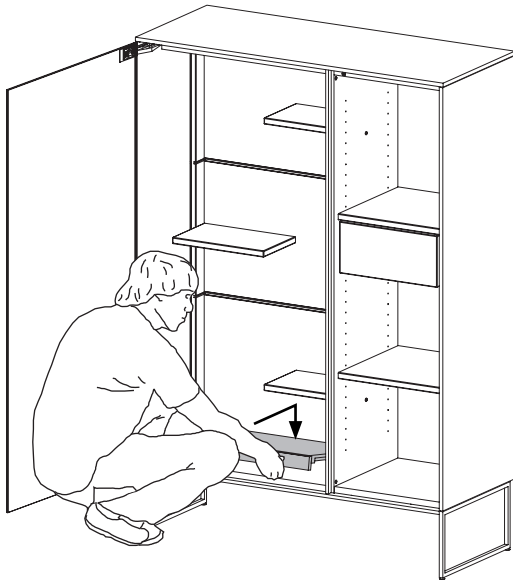

## 11. Insert glass shelves

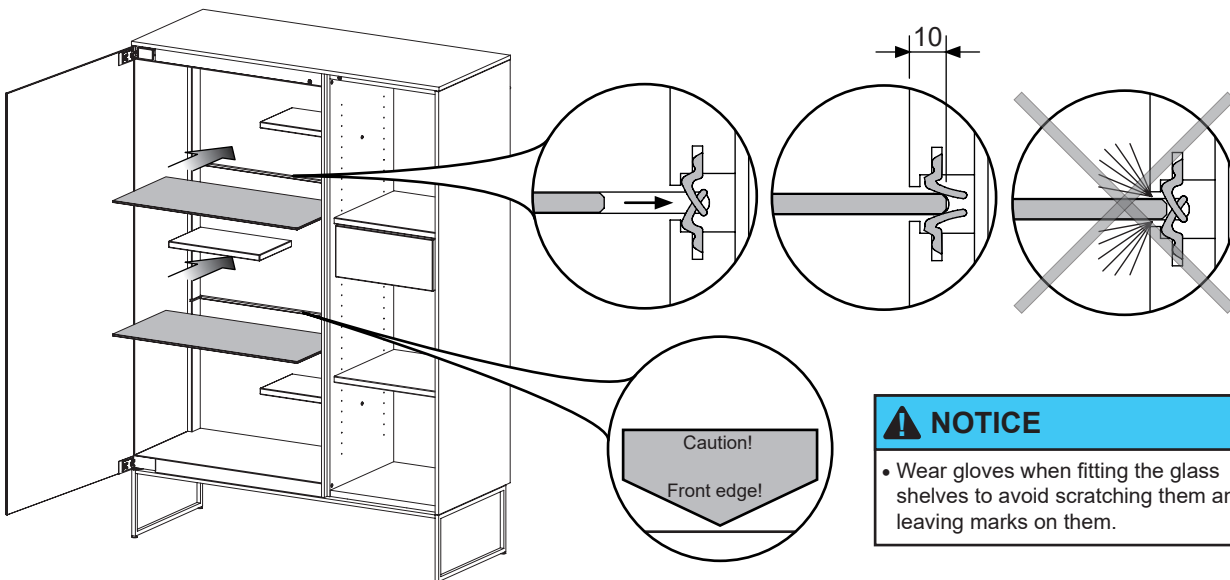

### **NOTICE**

- Wear gloves when fitting the glass shelves to avoid scratching them and leaving marks on them.

All dimensions in millimeters