

992 108

MONTAGEANLEITUNG INSTRUCTIONS DE MONTAGE ASSEMBLY INSTRUCTIONS MONTAGEAANWIJZING

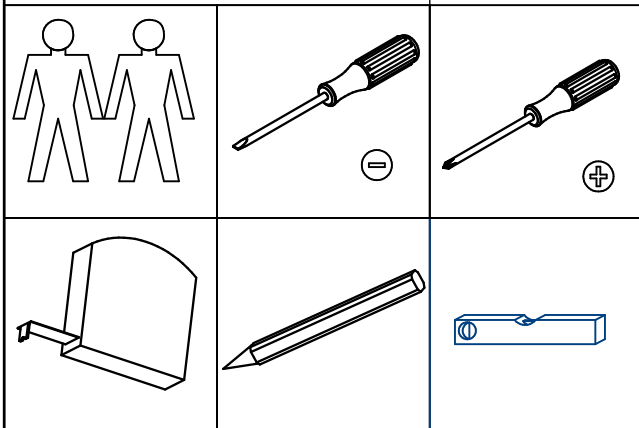

DEU - Beispiel
CZE - příklad
ESP - Ejemplo
FRA - exemple
GBR - example
HUN - példa
ITA - Esempio
NLD - voorbeeld
POL - Przykład
PRT - Exemplo
SVN - primer
ROU - Exemplu
RUS - пример
TUR - Örnek

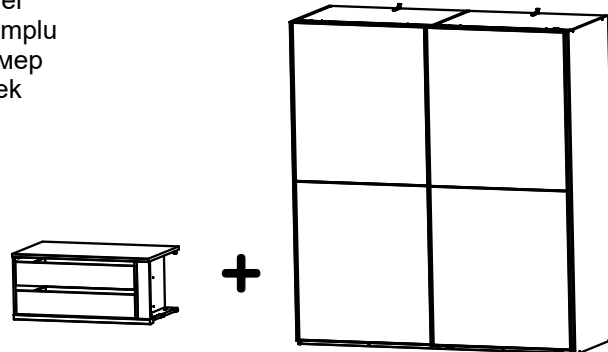

Deutsch - Alle Pakete öffnen und alle Aufbauanleitungen und Sicherheitshinweise lesen. Fachkundige Montage erforderlich. Unsachgemäße Montage kann zu Unfällen führen. Möbel/Gegenstand könnte kippen oder umfallen. **WICHTIG!** Achten Sie darauf, dass Sie Schrauben/Beschläge entsprechend der Wand-/Decken-beschaffenheit und mit ausreichender Tragfähigkeit verwenden. Erkundigen Sie sich ggf. beim Eisenwarenfachhandel.

Français - Ouvrir tous les paquets et lire toutes les instructions de montage et les consignes de sécurité. Montage par un spécialiste nécessaire. Un montage non conforme peut entraîner des accidents. Le meuble/l'objet pourrait basculer ou tomber. **IMPORTANT !** Veuillez à utiliser des vis/ferrures adaptées à la nature du mur/plafond et présentant une capacité de charge suffisante. Le cas échéant, renseignez-vous auprès d'une quincaillerie spécialisée.

Español - Abra todos los paquetes y lea todas las instrucciones de montaje y de seguridad. Se requiere un montaje cualificado. Un montaje incorrecto puede provocar accidentes. El mueble/objeto podría volcar o caerse. **¡IMPORTANTE!** Asegúrese de utilizar tornillos/herrajes adecuados para la pared/techo y con suficiente capacidad de carga. En caso necesario, infórmese en una ferretería.

Português - Abrir todas as embalagens e ler todas as instruções de montagem e de segurança. É necessária uma montagem competente. Uma montagem incorrecta pode provocar acidentes. O móvel/objeto pode tombar ou cair. **IMPORTANTE!** Certifique-se de que utiliza parafusos/conexões adequados à parede/teto e com capacidade de carga suficiente. Se necessário, informe-se numa loja de ferragens.

Nederlands - Open alle verpakkingen en lees alle montage- en veiligheidsinstructies. Vakkundige montage vereist. Onjuiste montage kan leiden tot ongelukken. Meubels/voorwerpen kunnen kantelen of omvallen. **BELANGRIJK!** Zorg ervoor dat je schroeven/beslag gebruikt die geschikt zijn voor de muur/het plafond en voldoende draagkracht hebben. Informeer indien nodig bij een ijzerhandel.

Magyar - Nyissa ki az összes csomagot, és olvassa el az összes összeszerelési útmutatót és biztonsági utasítást. Szakképzett összeszerelés szükséges. A nem megfelelő összeszerelés balesethez vezethet. A bútor/tárgy felborulhat vagy eleshet. **FONTOS!** Ügyeljen arra, hogy a falhoz/mennyezethez megfelelő és megfelelő teherbírású csavarokat/szerelvényeket használjon. Szükség esetén érdeklődjön egy barkácsáruházban.

Italiano - Aprire tutte le confezioni e leggere tutte le istruzioni di montaggio e di sicurezza. È necessario un montaggio esperto. Un montaggio non corretto può causare incidenti. Il mobile/oggetto potrebbe ribaltarsi o cadere. **IMPORTANTE!** Assicurarsi di utilizzare viti/raccordi adatti alla parete/soffitto e con una capacità di carico sufficiente. Se necessario, rivolgersi a un ferramenta.

Slovensky - Odprite vse pakete in preberite vsa navodila za montažo in varnostna navodila. Potrebno je kvalificirano sestavljanje. Nepravilna montaža lahko privede do nesreč. Pohištvo/predmet se lahko prevrne ali pade. **POMEMBNO!** Prepričajte se, da uporabljate vijake/priključke, ki so primerni za steno/strop in imajo zadostno nosilnost. Po potrebi se pozanimajte v trgovini s strojno opremo.

English - Open all packages and read all assembly instructions and safety instructions. Skilled assembly required. Improper assembly can lead to accidents. Furniture/object could tip or fall over. **IMPORTANT!** Make sure that you use screws/fittings that are suitable for the wall/ceiling and have sufficient load-bearing capacity. If necessary, enquire at a hardware store.

Română - Deschideți toate ambalajele și citiți toate instrucțiunile de asamblare și instrucțiunile de siguranță. Este necesară o asamblare calificată. O asamblare necorespunzătoare poate duce la accidente. Mobilă/obiectul s-ar putea răsturna sau cădea. **IMPORTANT!** Asigurați-vă că folosiți șuruburi/fitinguri adecvate pentru perete/plafon și că au o capacitate portantă suficientă. Dacă este necesar, interesați-vă la un magazin de feronerie.

Türkçe - Tüm paketleri açın ve tüm montaj talimatlarını ve güvenlik talimatlarını okuyun. Nitelikli montaj gereklidir. Yanlış montaj kazalara yol açabilir. Mobilya/nesne devrilebilir veya düşebilir. **ÖNEMLİ!** Duvara/tavana uygun ve yeterli yük taşıma kapasitesine sahip vidalar/ bağıntı parçaları kullanmanızdan emin olun. Gerekirse bir hırdavatçıdan bilgi alın.

Česky - Otevřete všechna balení a přečtěte si všechny montážní a bezpečnostní pokyny. Je nutná kvalifikovaná montáž. Nesprávná montáž může vést k nehodám. Nábytek/předmět by se mohl převrátit nebo spadnout. **DŮLEŽITÉ!** Dbejte na to, abyste použili šrouby/kování, které jsou vhodné pro stěnu/strop a mají dostatečnou nosnost. V případě potřeby se informujte v železářství.

Polski - Otwórz wszystkie opakowania i przeczytaj wszystkie instrukcje montażu i instrukcje bezpieczeństwa. Wymagany jest wykwalifikowany montaż. Nieprawidłowy montaż może prowadzić do wypadków. Meble/przedmioty mogą się przewrócić lub spaść. **WAŻNE!** Upewnij się, że używasz śrub/złączek, które są odpowiednie do ściany/sufitu i mają wystarczającą nośność. W razie potrzeby należy skontaktować się ze sklepem z narzędziami.

Русский - Вскройте все упаковки и ознакомьтесь со всеми инструкциями по сборке и правилами техники безопасности. Требуется квалифицированная сборка. Неправильная сборка может привести к несчастным случаям. Мебель/предмет может опрокинуться или упасть. **ВАЖНО!** Убедитесь, что используемые винты/фурнитура подходят для стены/потолка и обладают достаточной несущей способностью. При необходимости обратитесь в хозяйственный магазин.

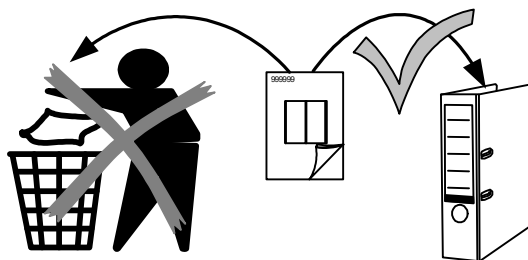

Typ a

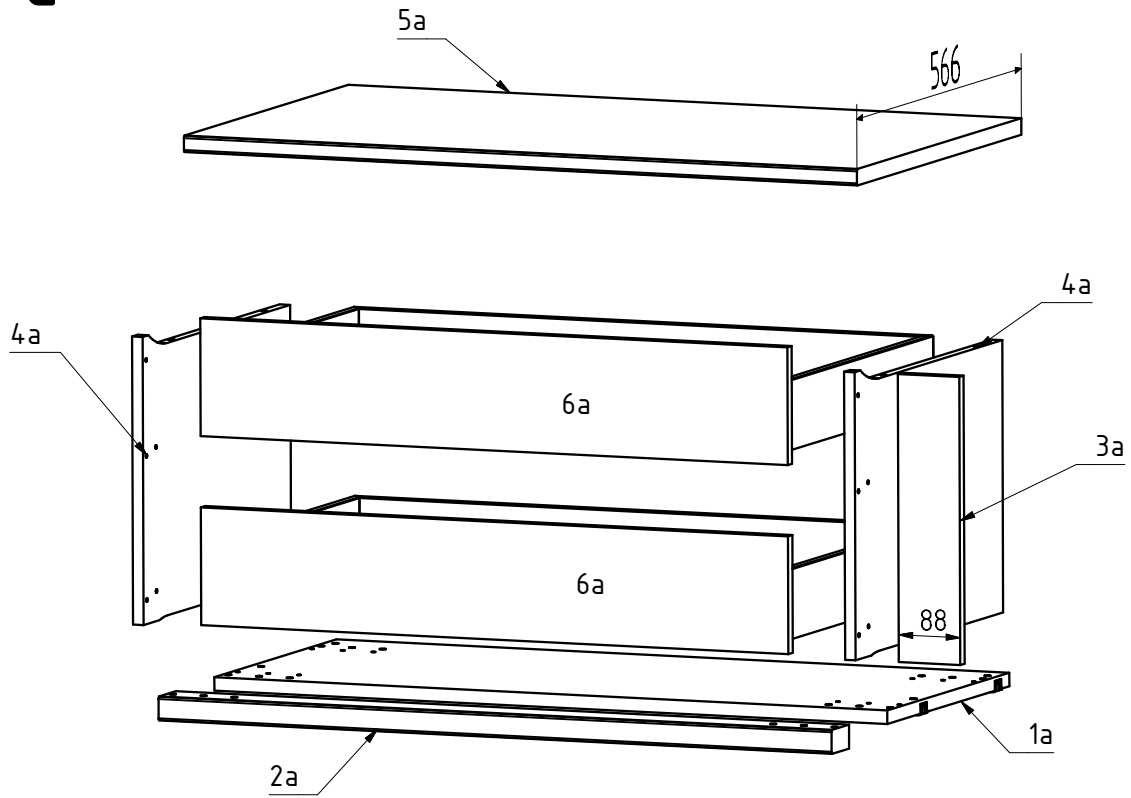

Typ b

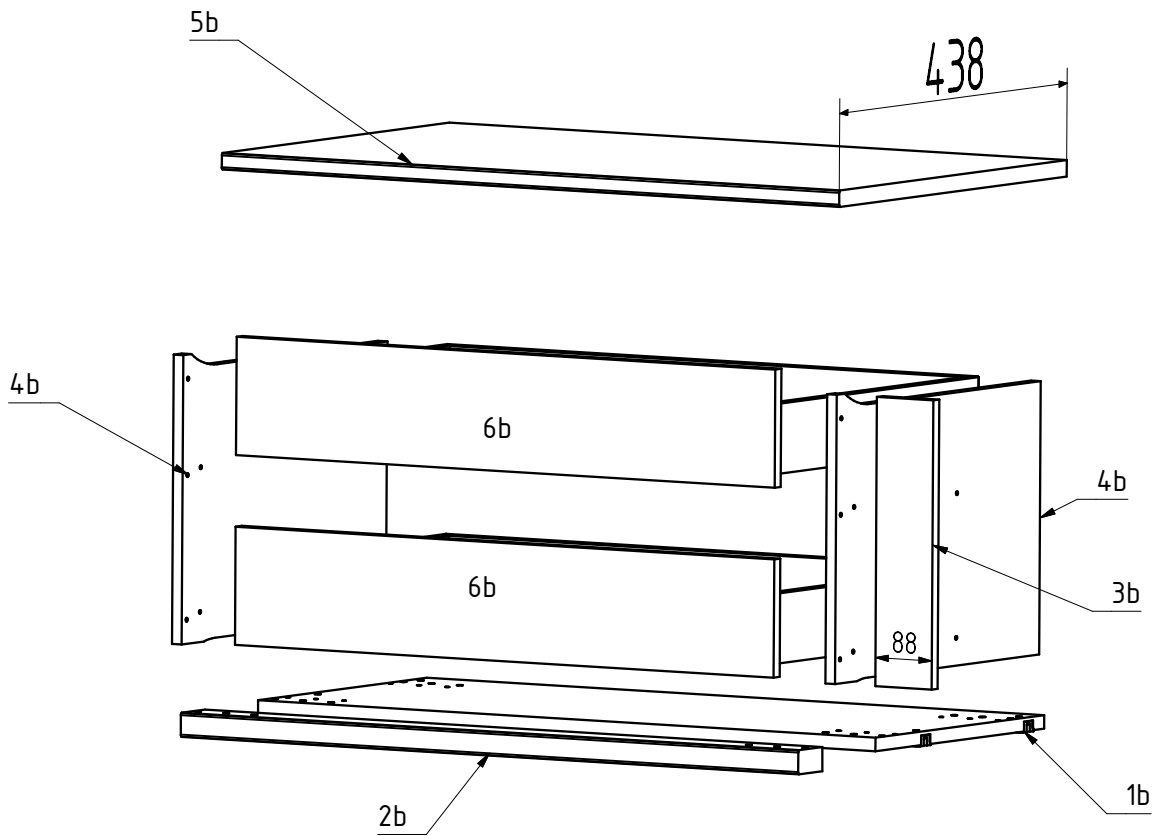

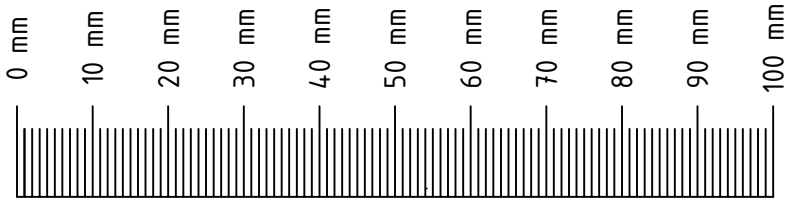

<p>4x 111 229</p>	<p>2x 111 235</p>	<p>3,5x40 6x 121119</p>	<p>5x30 4x 353 005</p>	<p>8x40 10x 353 007</p>	<p>2x 111 049</p>	<p>6,3x11 10x 121 167</p>
<p>0-2x 112 521</p>		<p>0-2x 112 523</p>		<p>4,5x15 4x 121 098</p>	<p>2x 111 036</p>	

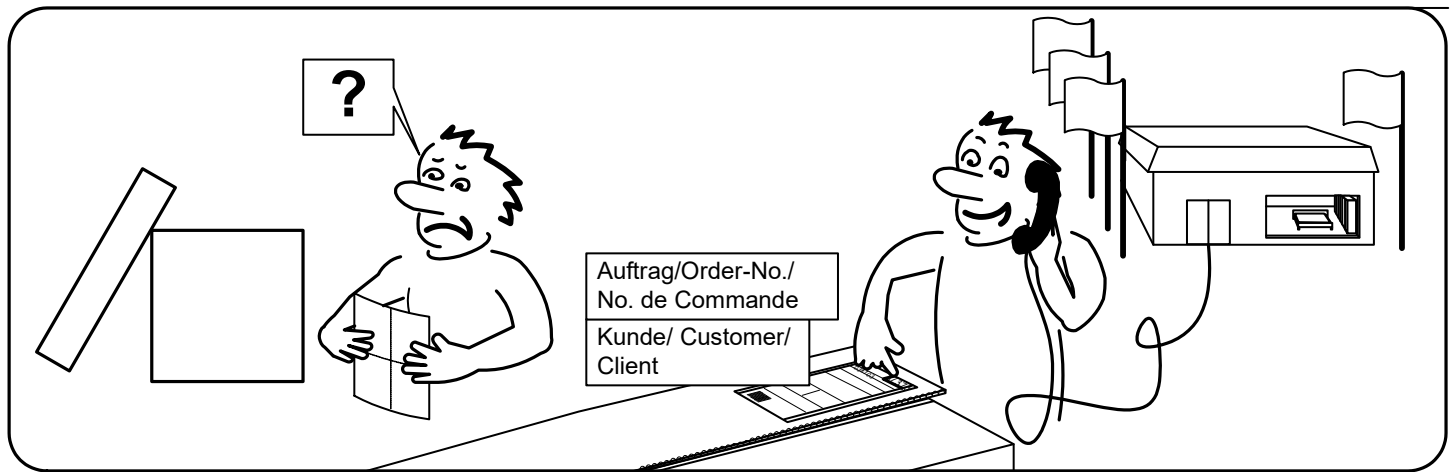

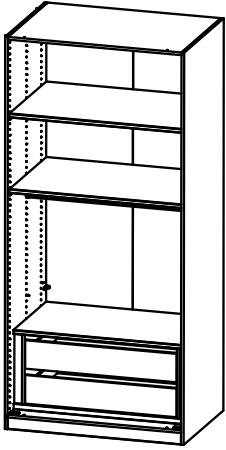

A - L

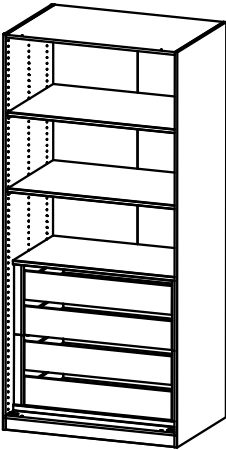

A - F + Y - AI

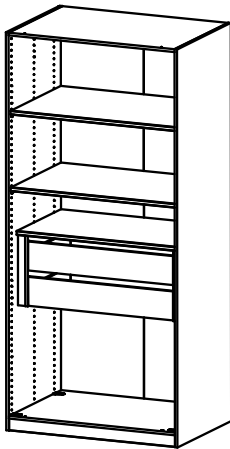

M - X

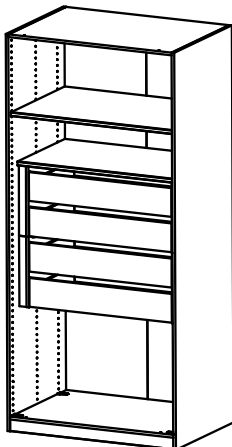

M - S + Y - AI

A

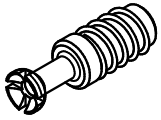

4x 111 229

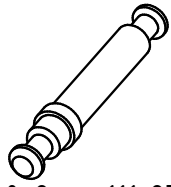

0-2x 111 235

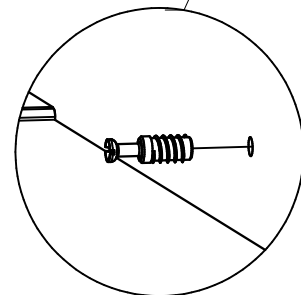
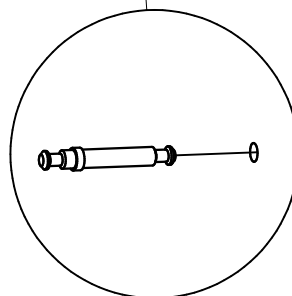
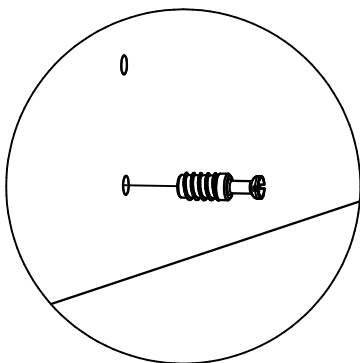
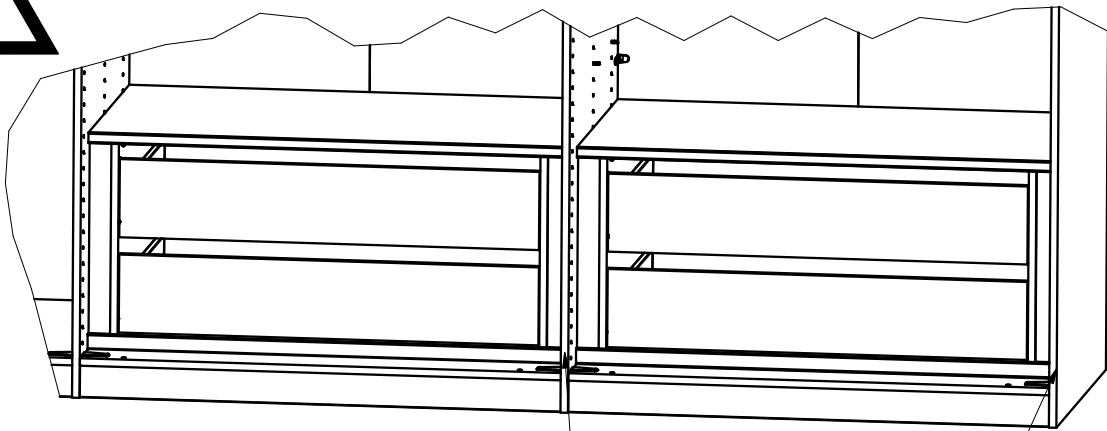
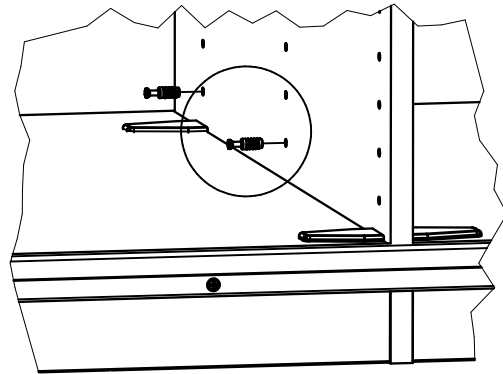
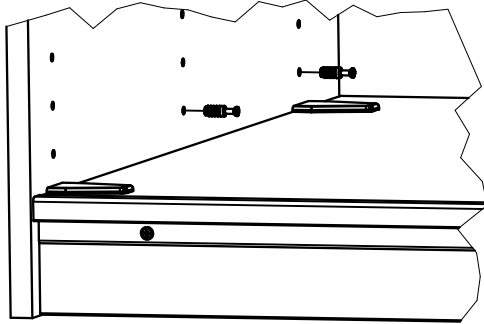
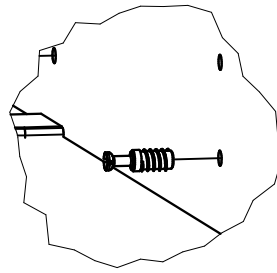

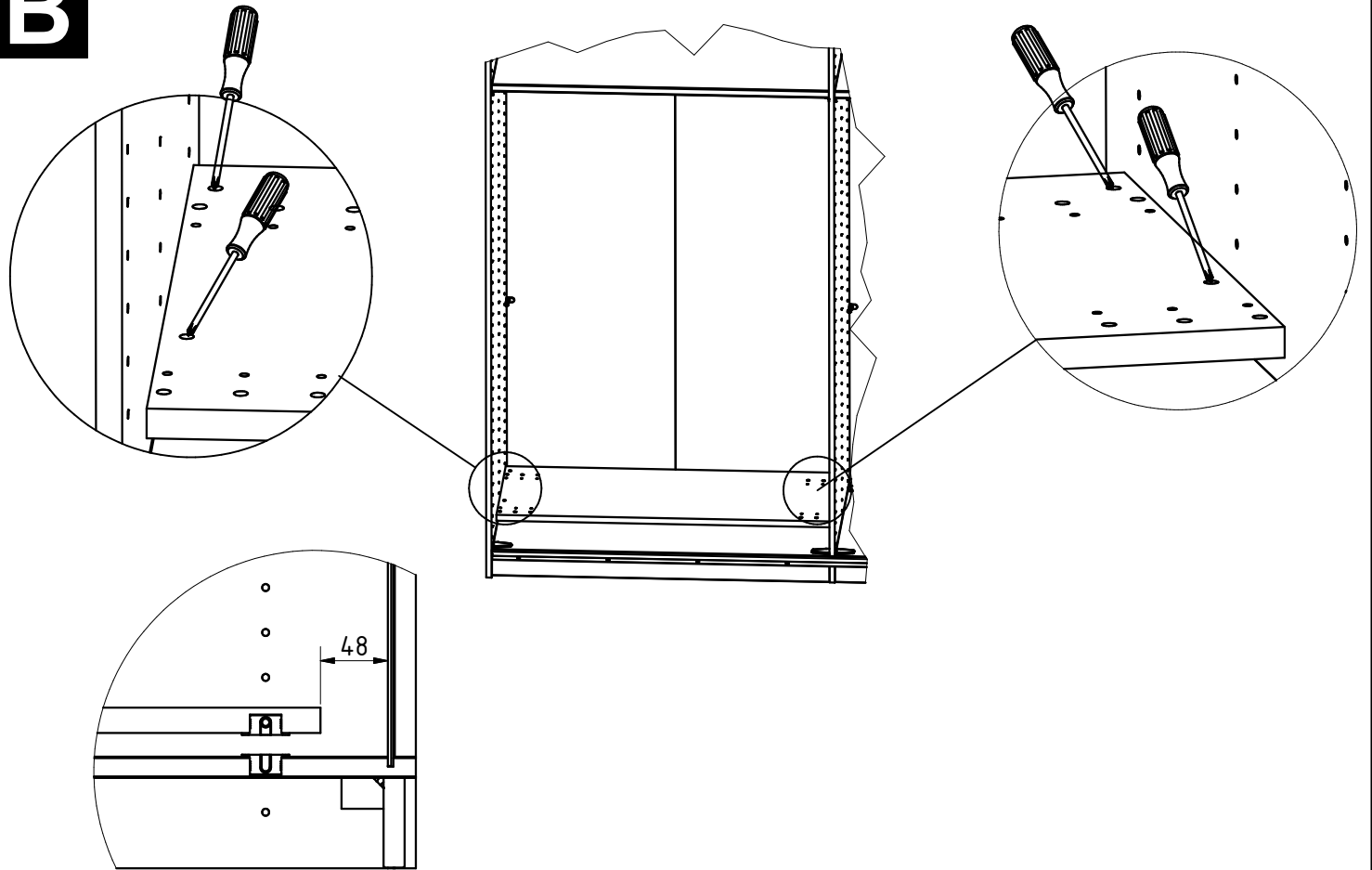
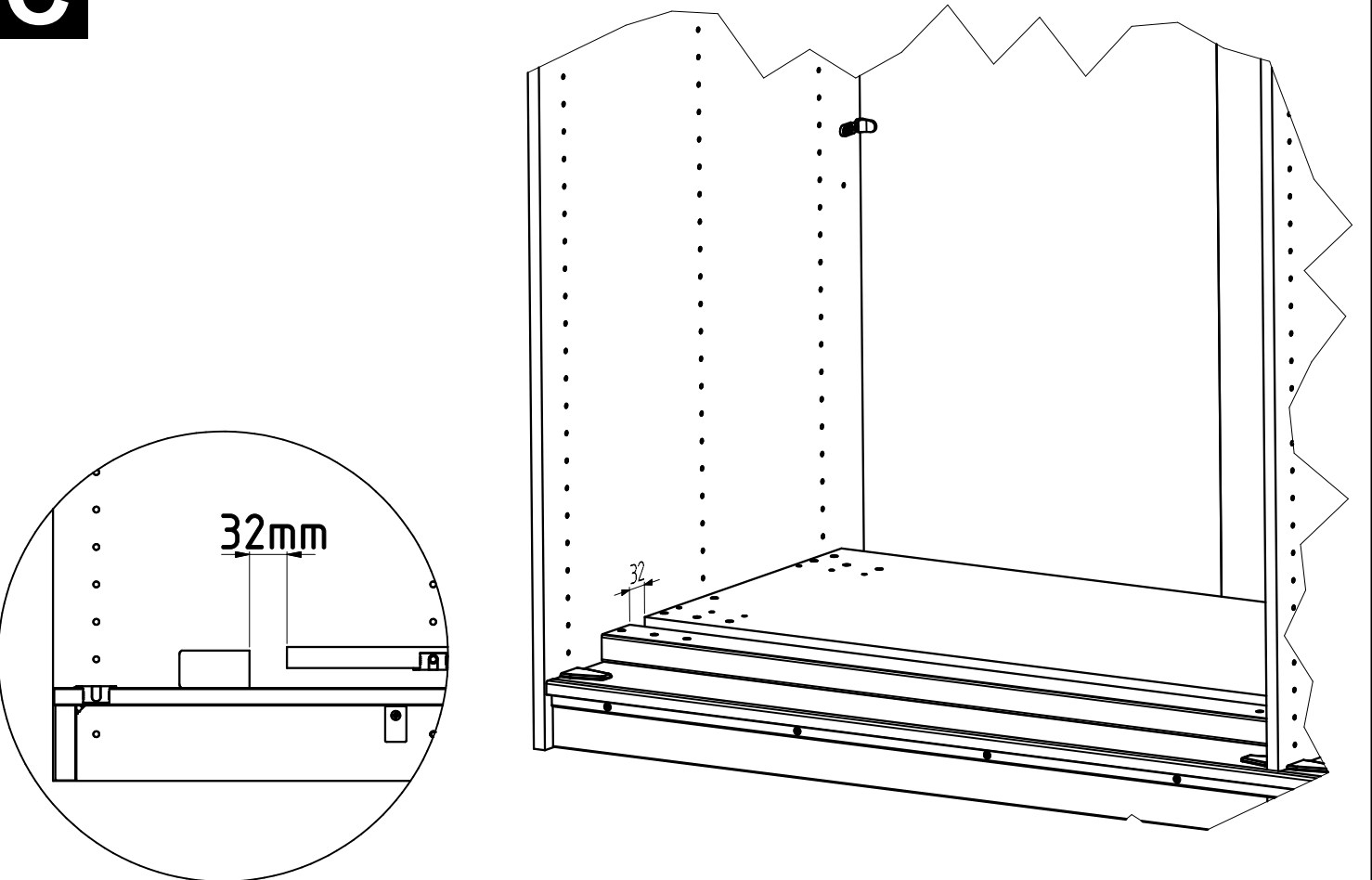
B**C**

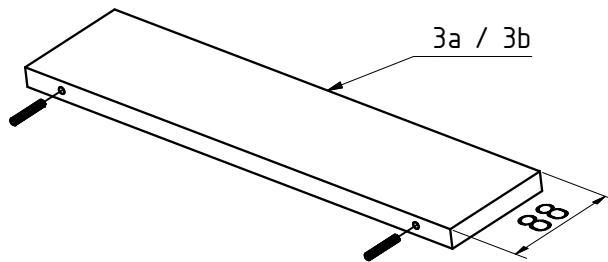
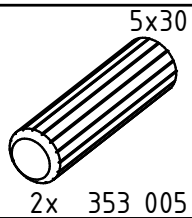
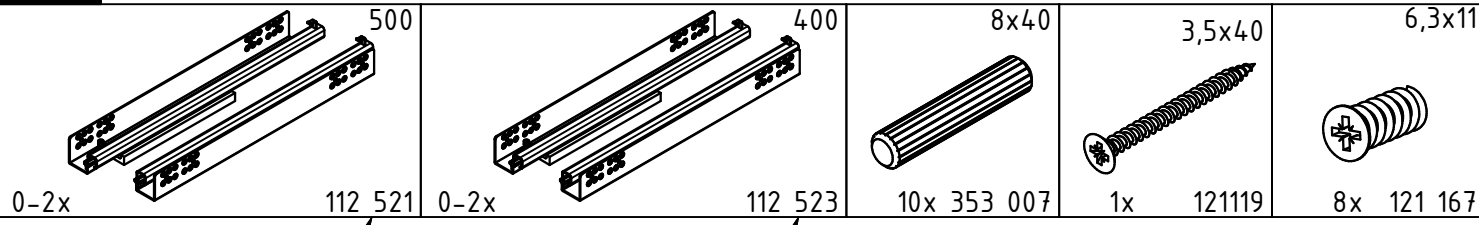
D**E**

Typ a

Typ b

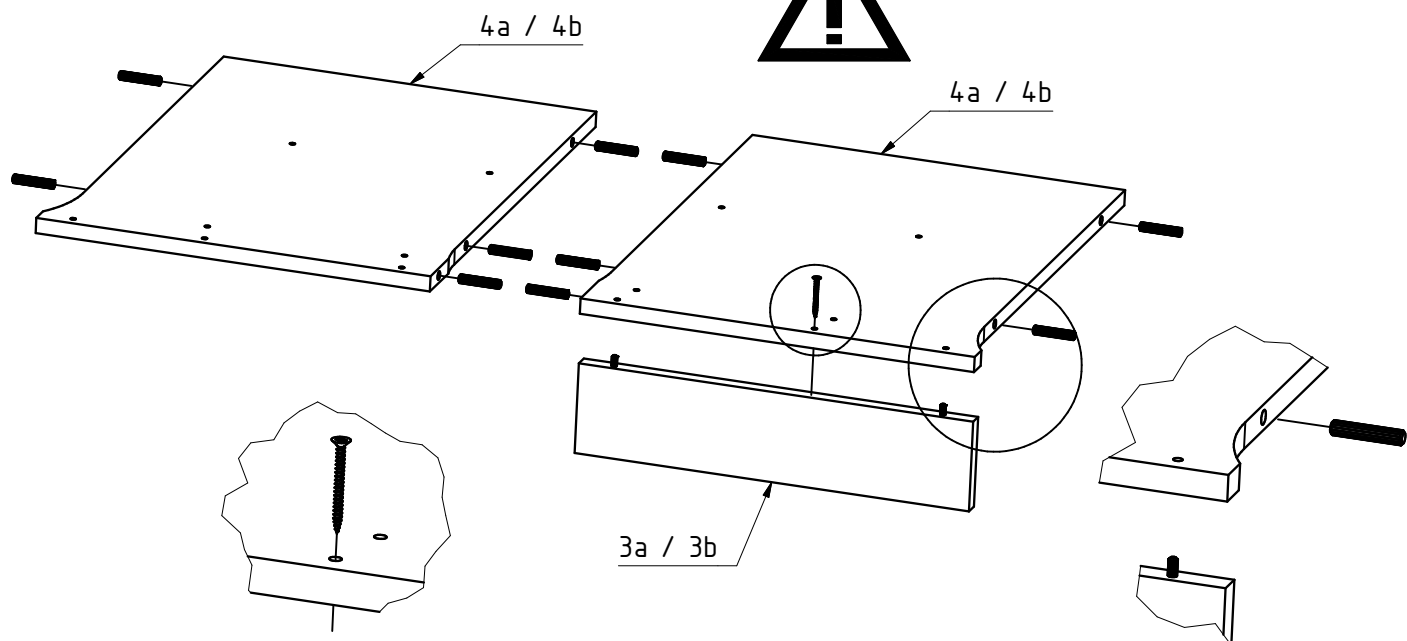
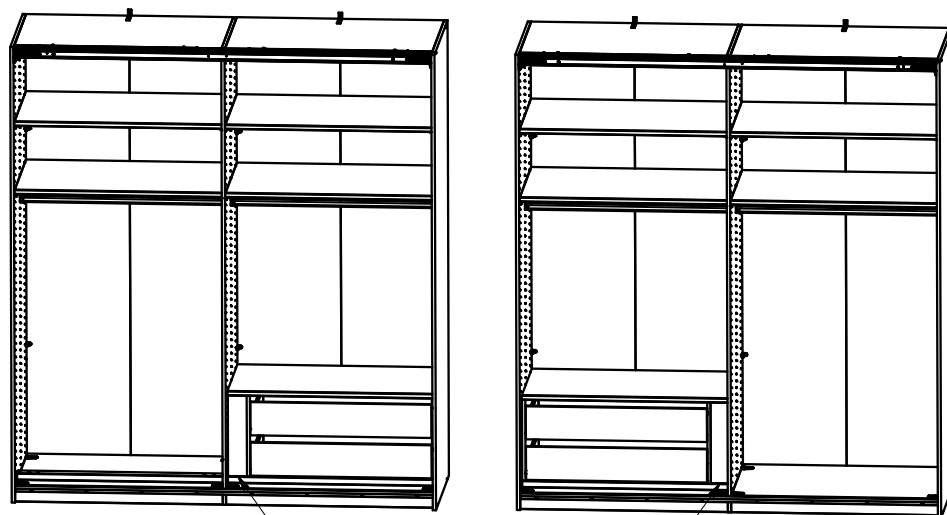

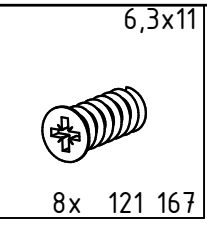
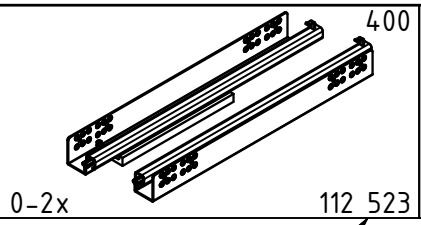
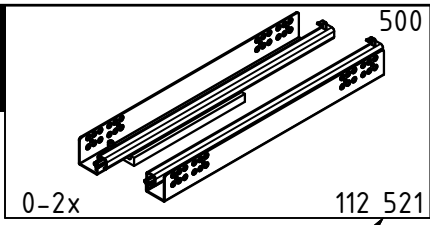
F

Typ a

Typ b

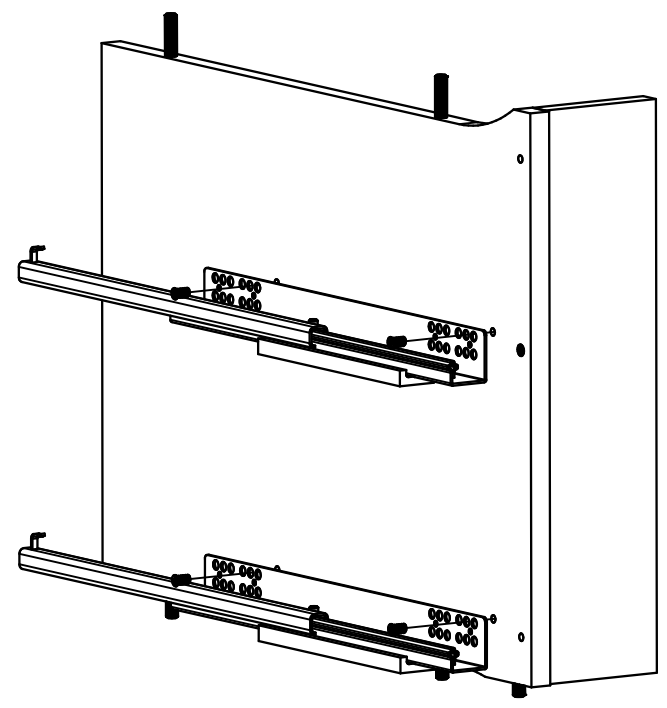
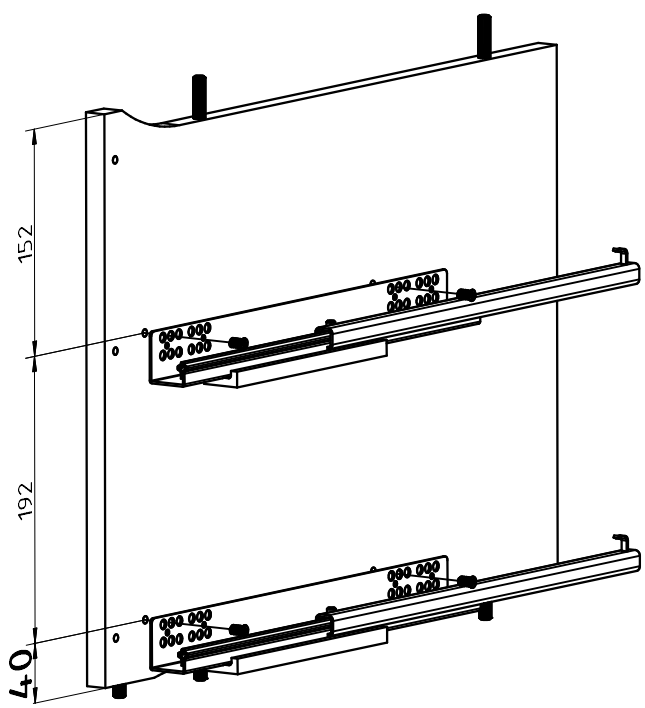
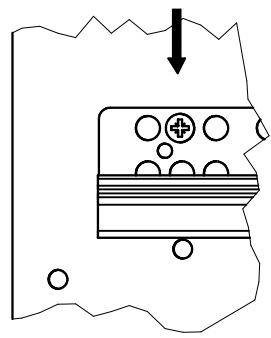

G

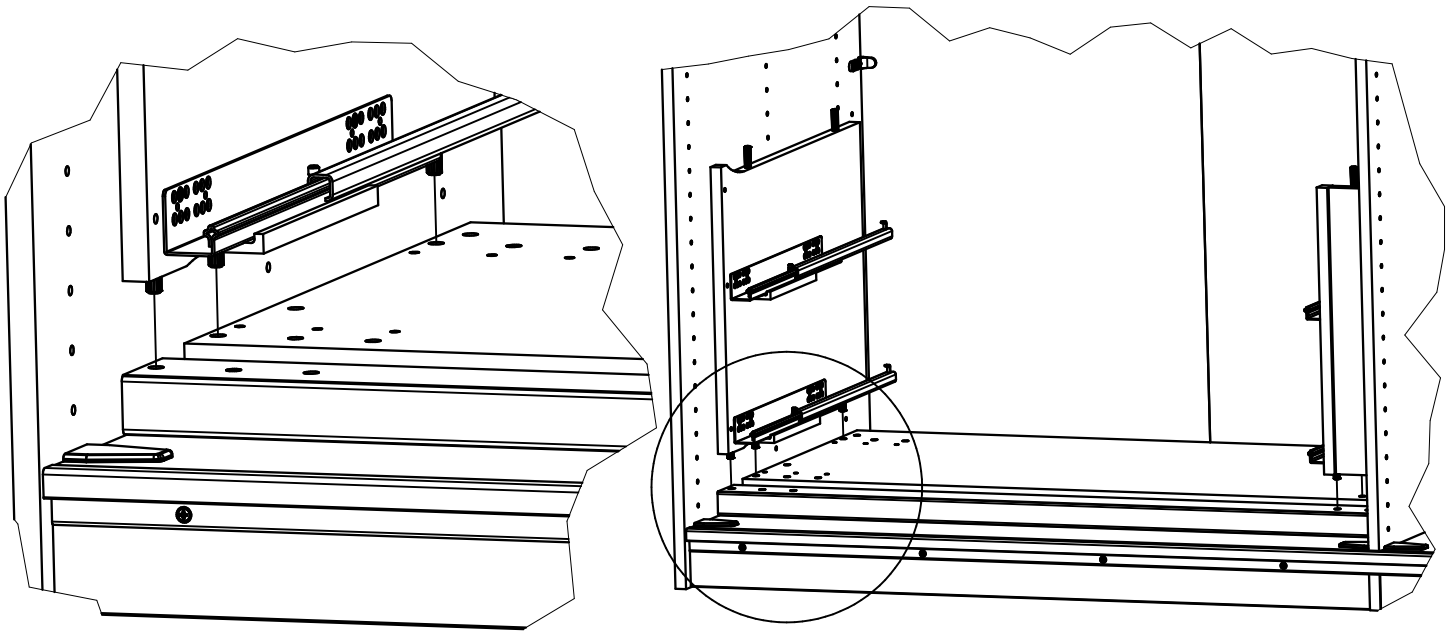

H

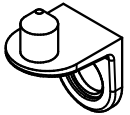

2x 111 049
6,3x11



10x 121 167

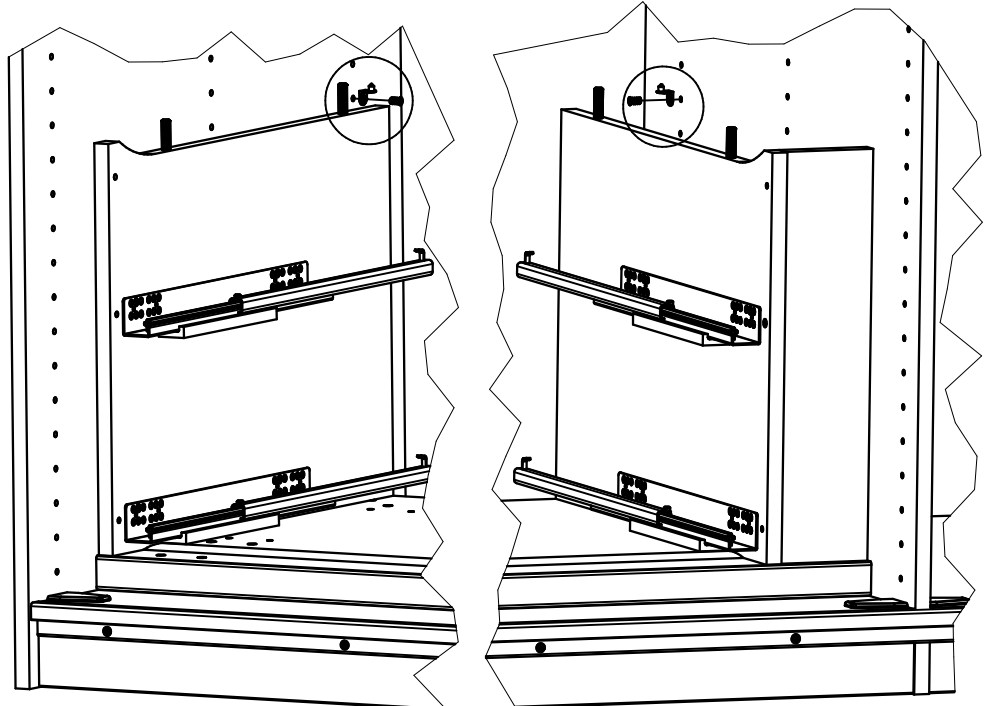
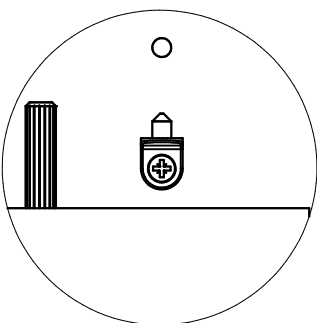
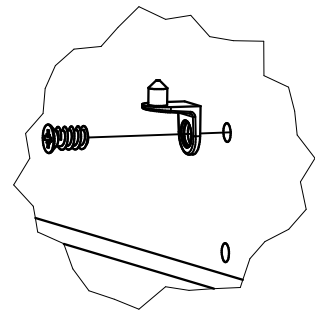
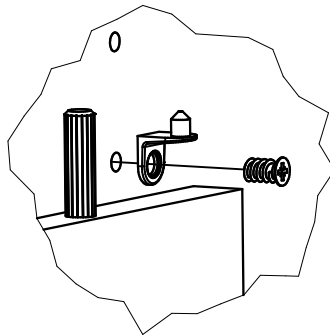

I

4,5x15

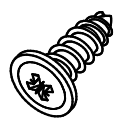

2x 121 098

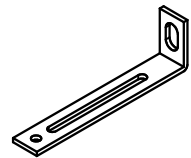

2x 111 036

5a / 5b

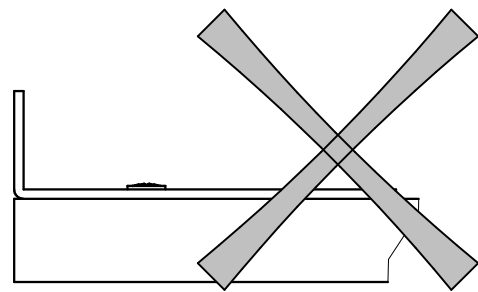
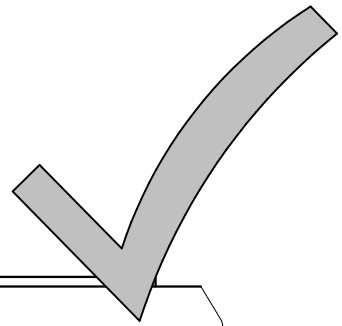
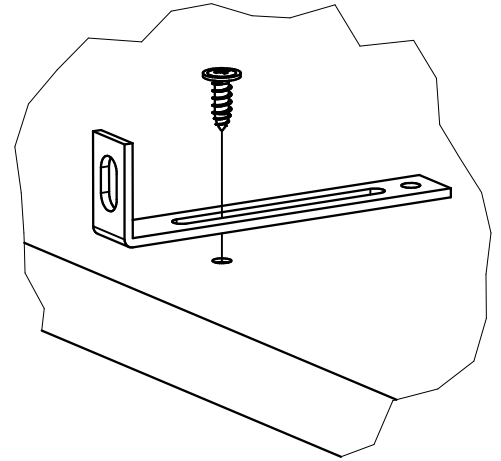
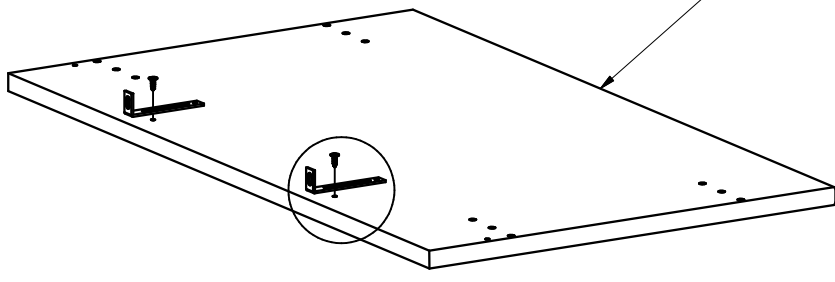

J

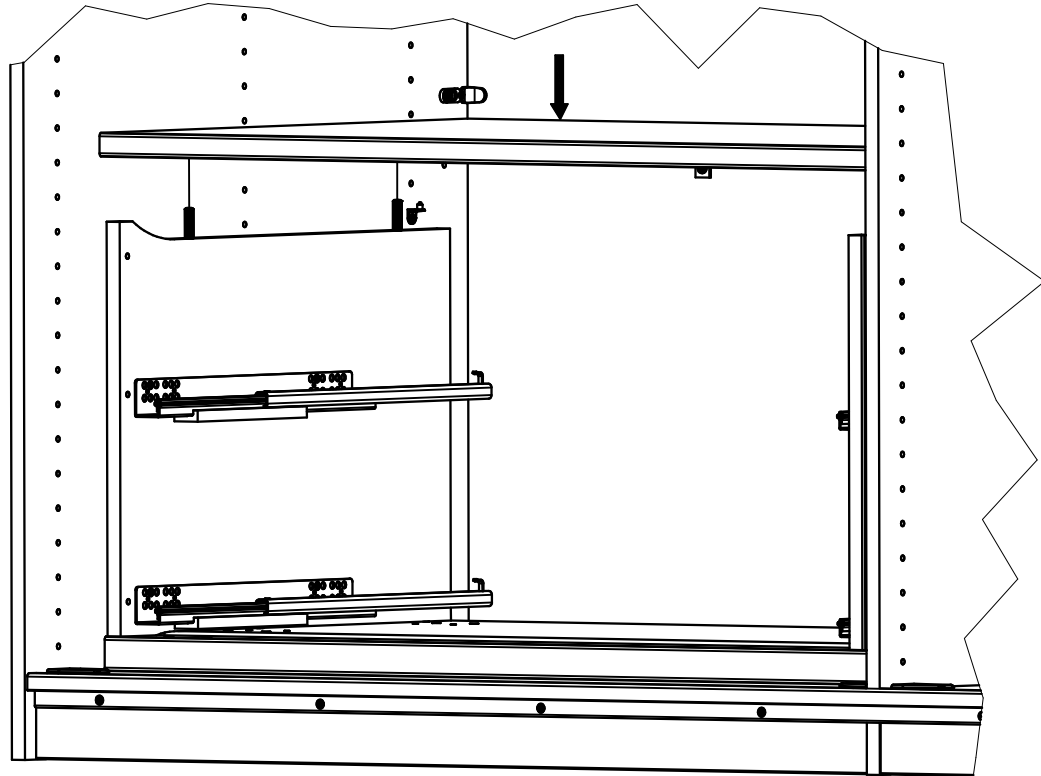

K

4,5x15



2x 121 098

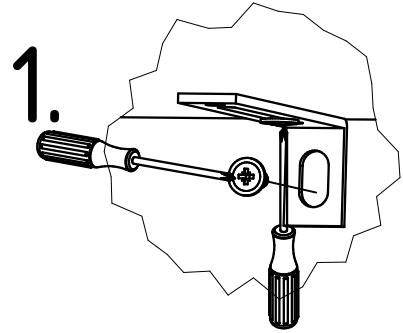
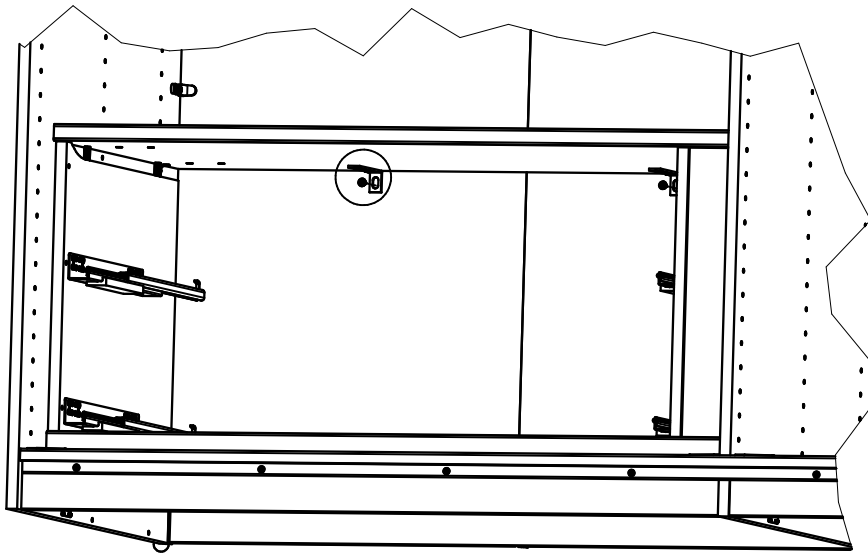

2.

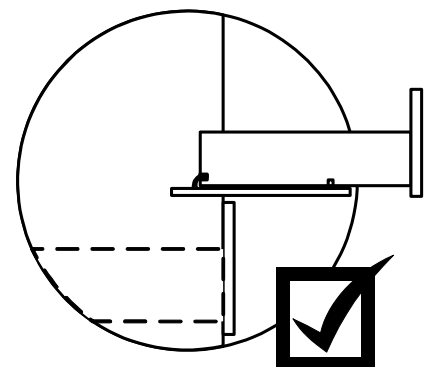
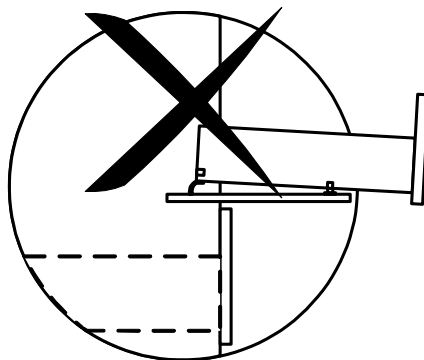
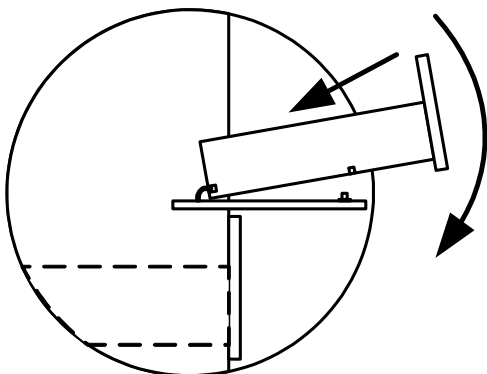
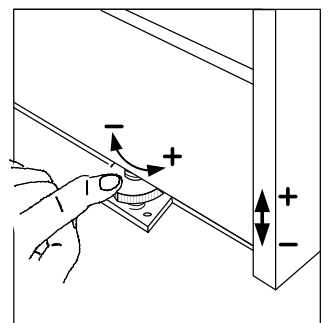
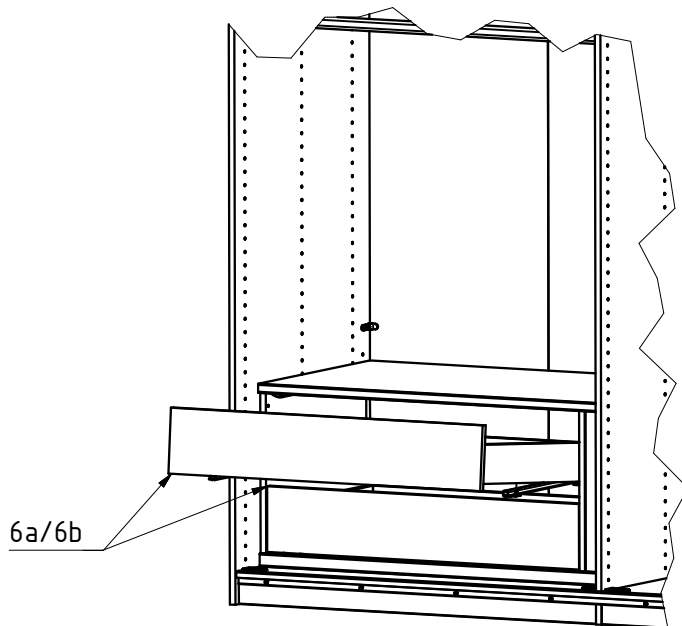
L

M

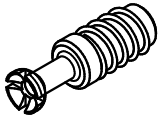

4x 111 229

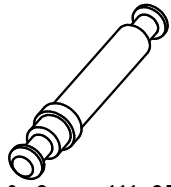

0-2x 111 235

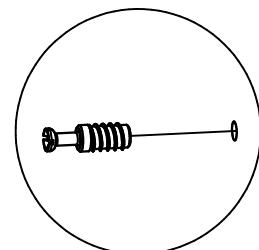
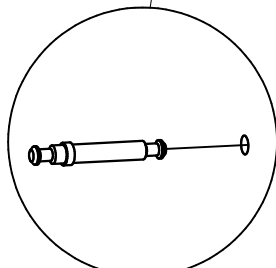
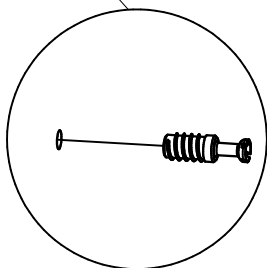
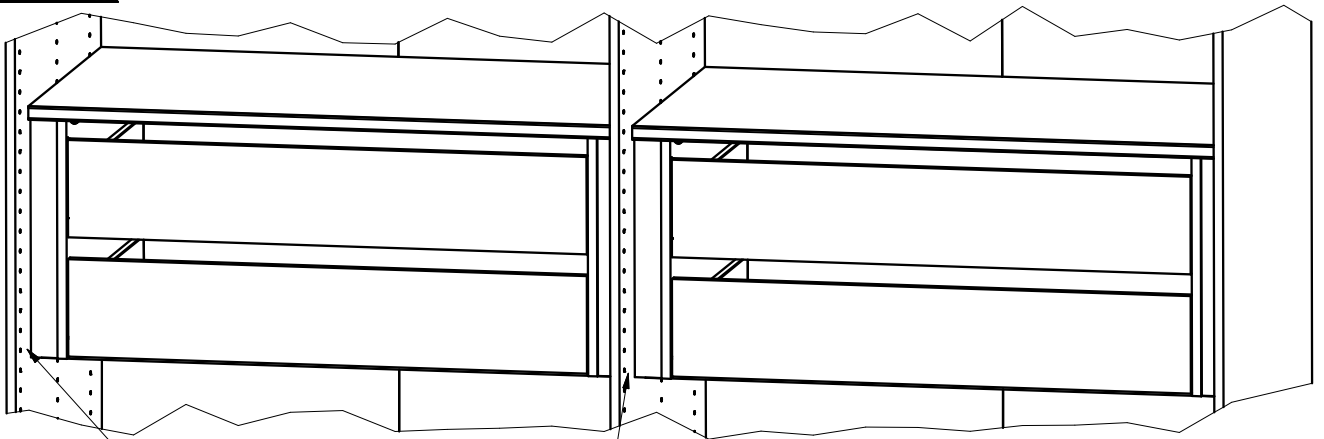
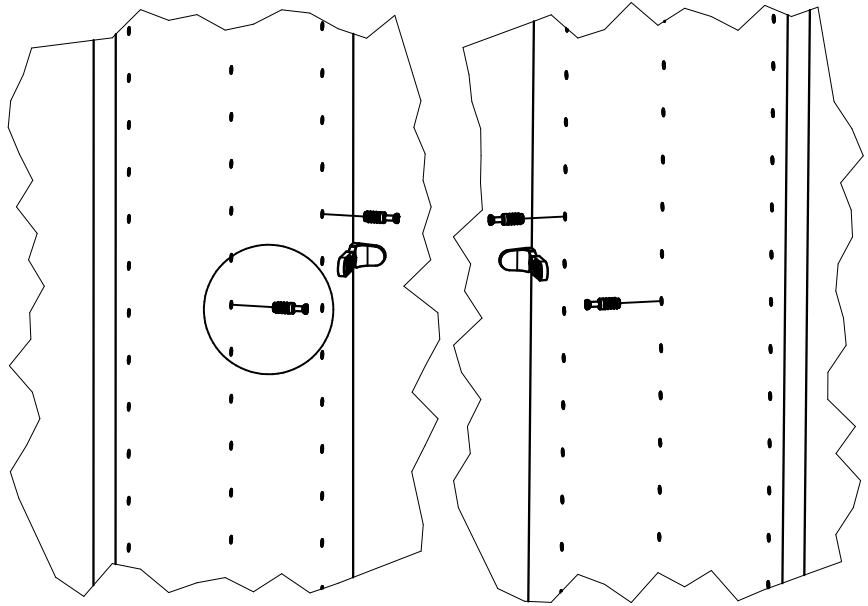
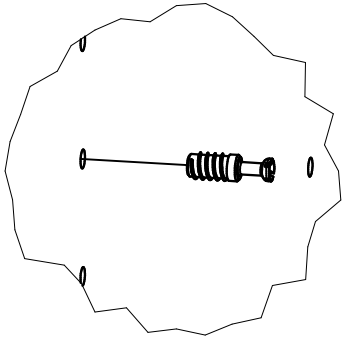

N

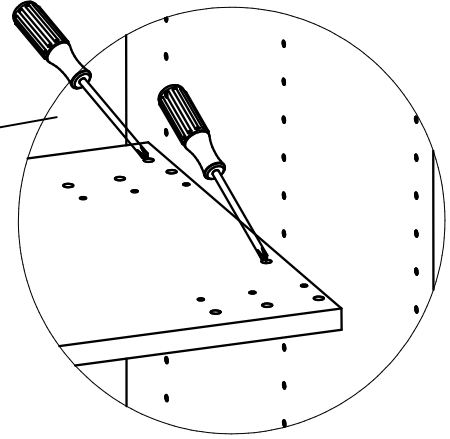
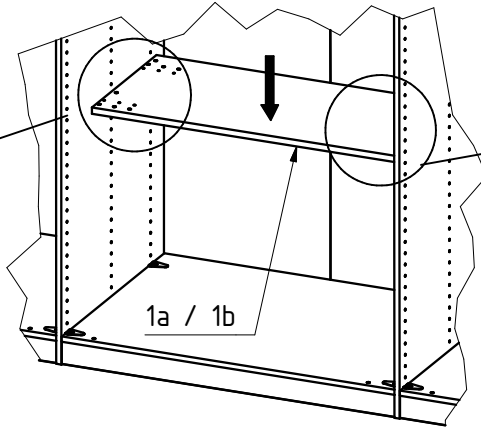
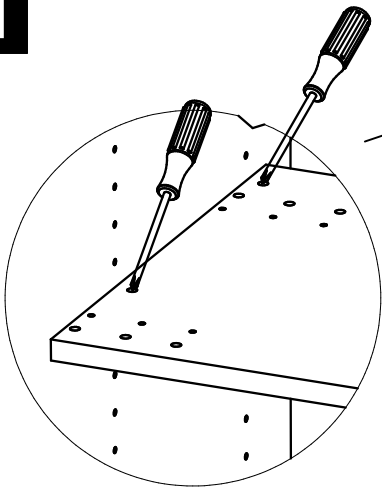

O

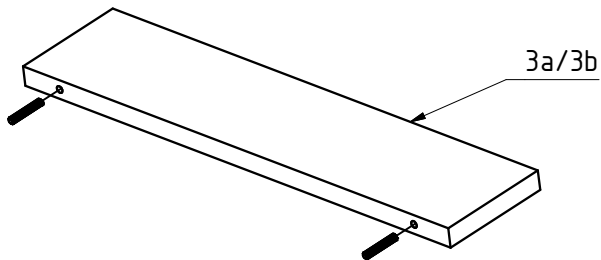
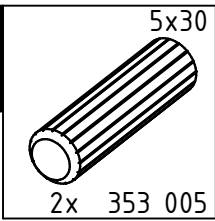

P

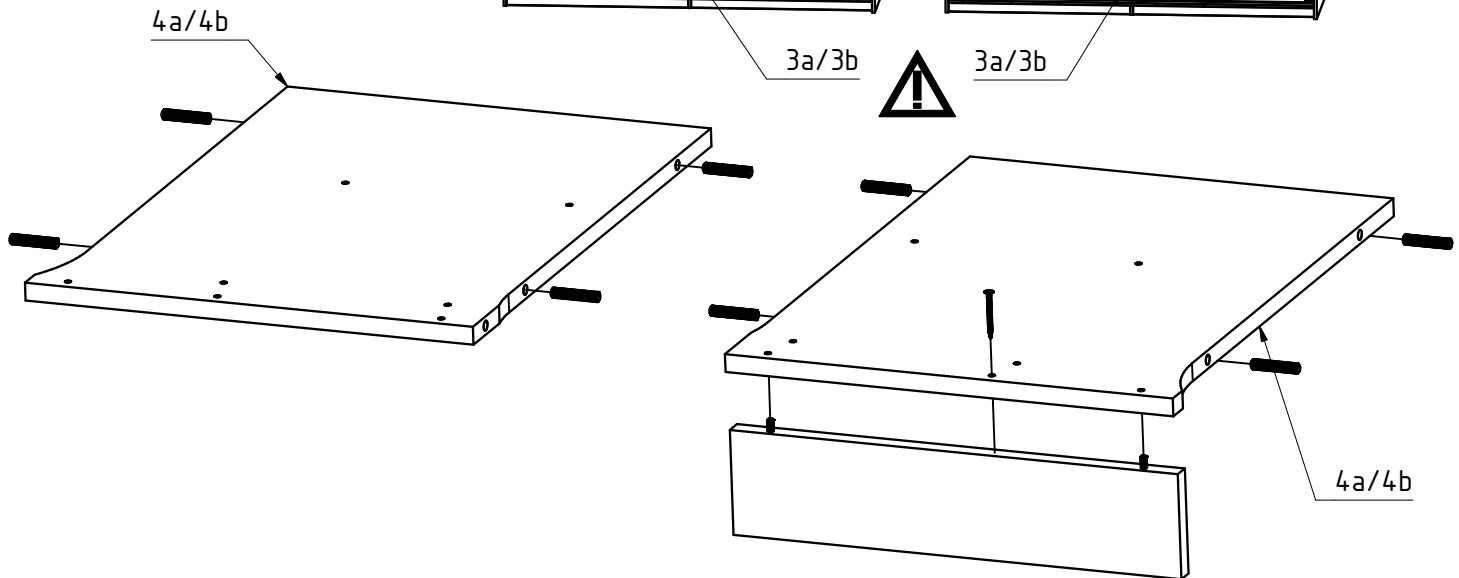
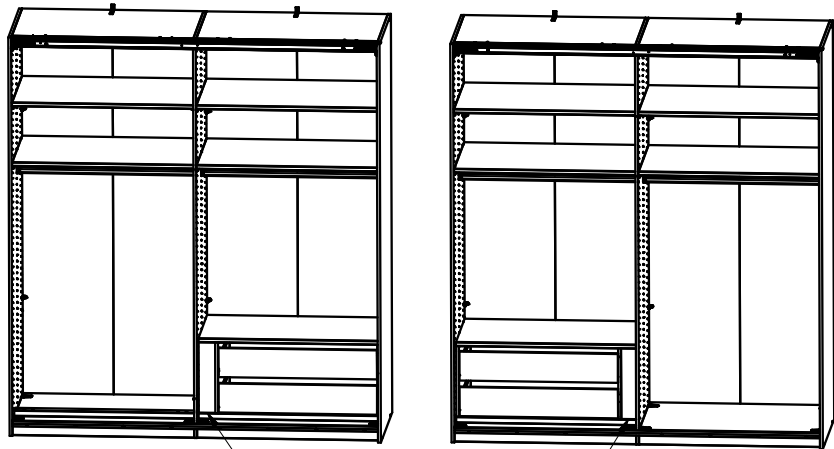
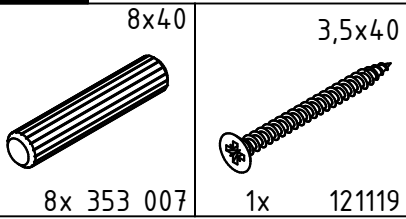

Q

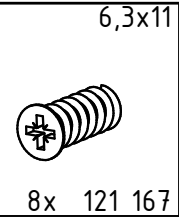
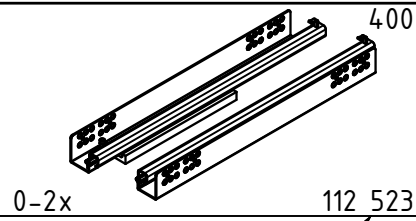
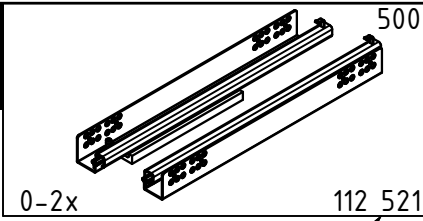

Typ a

Typ b

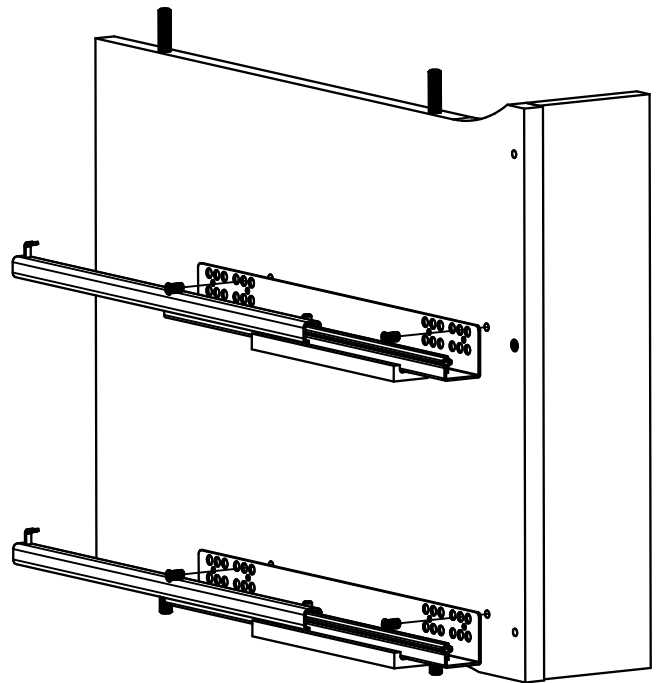
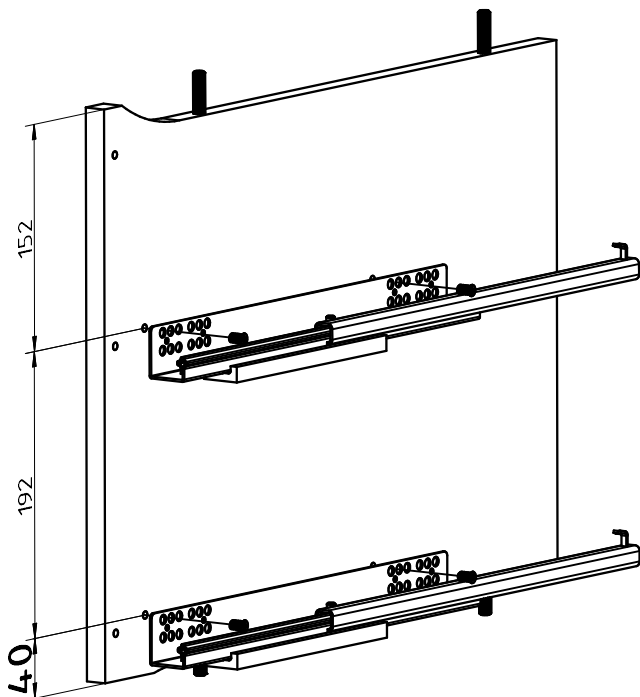
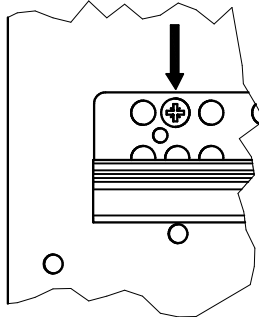

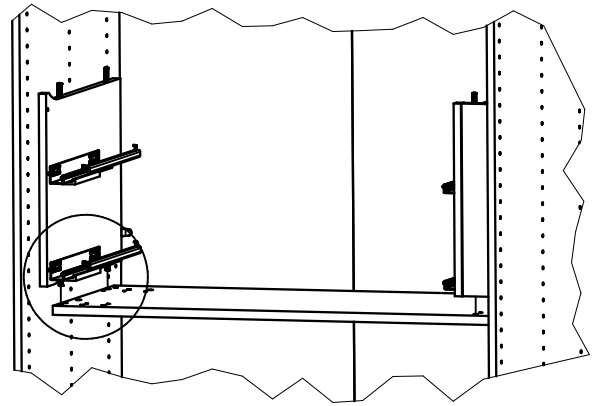
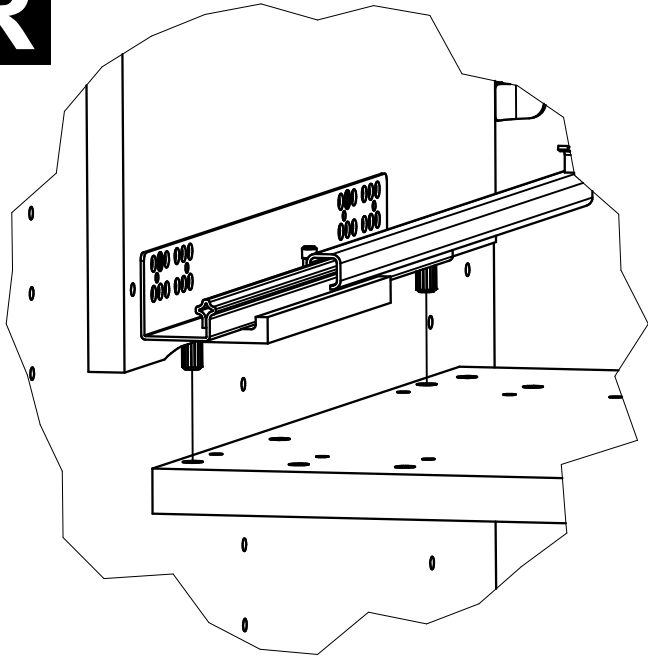
R**S**

3,5x40

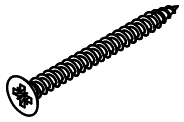

4x 121119

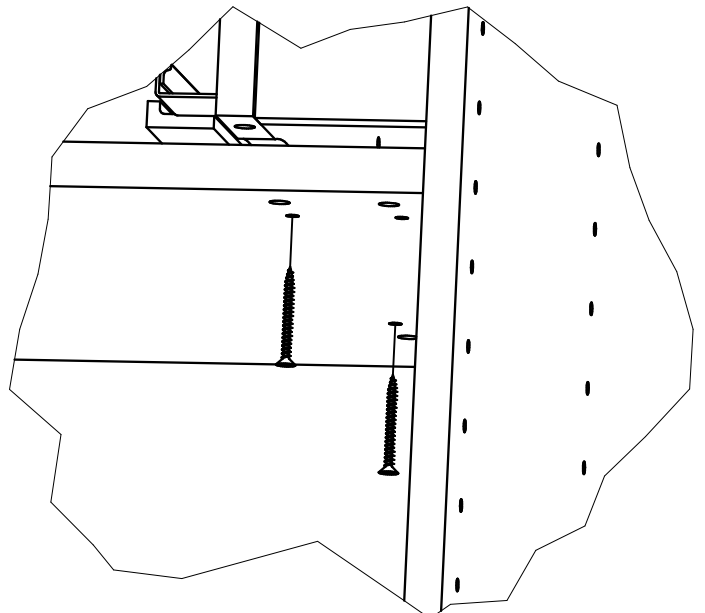
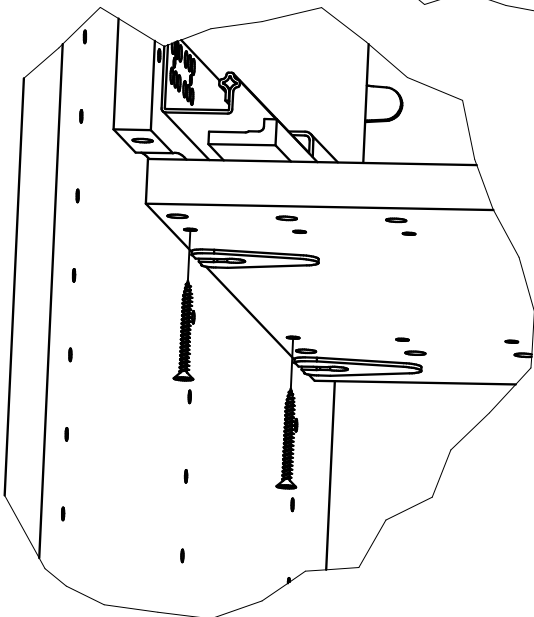
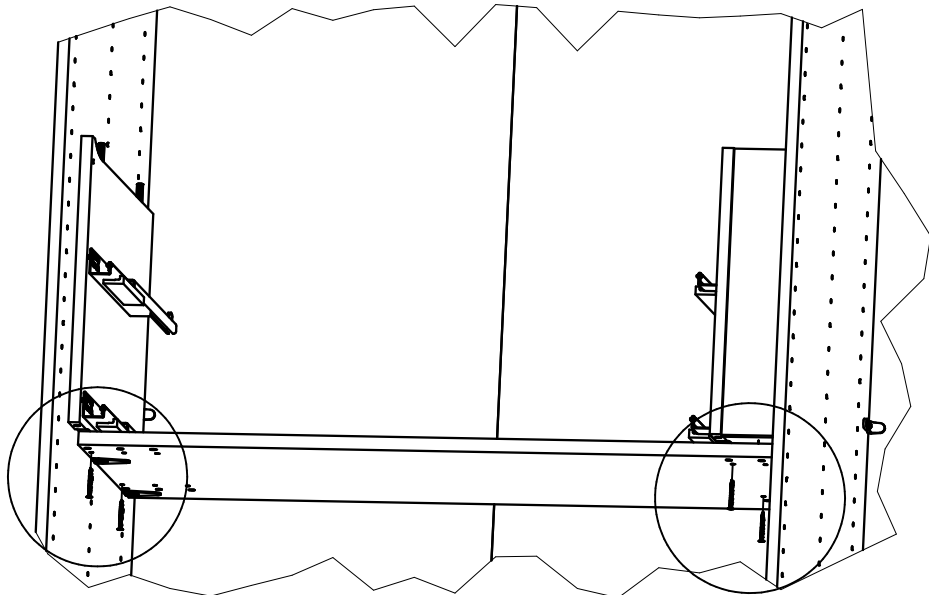

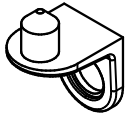
T

2x 111 049



10x 121 167

6,3x11

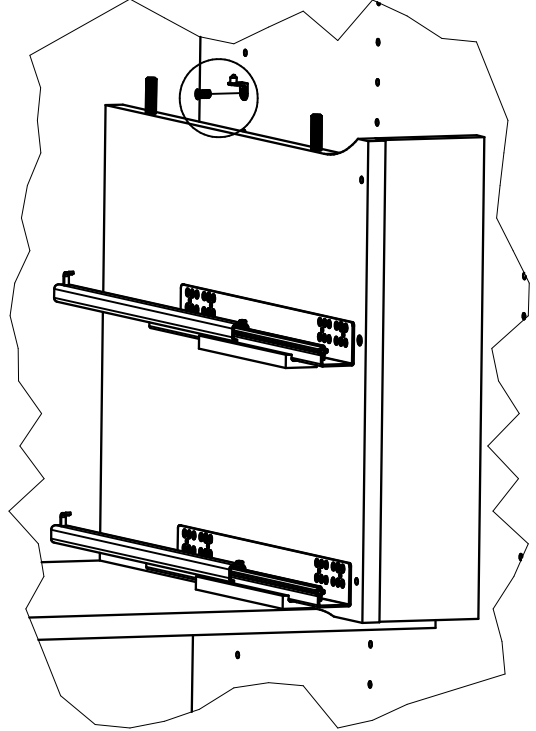
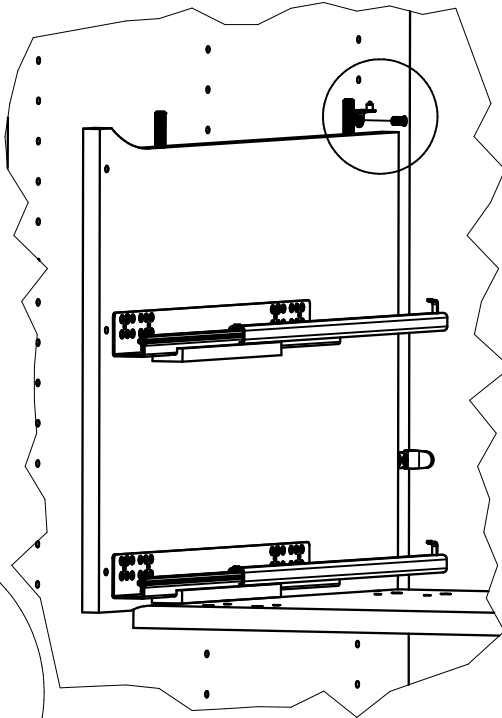
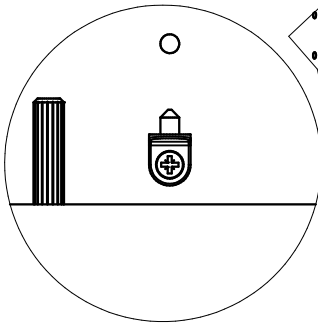
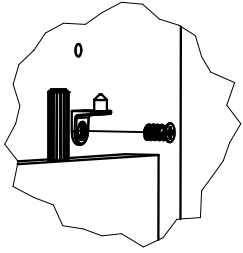
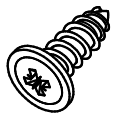
**U**

2x 121 098

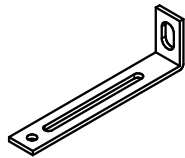

2x 111 036

4,5x15

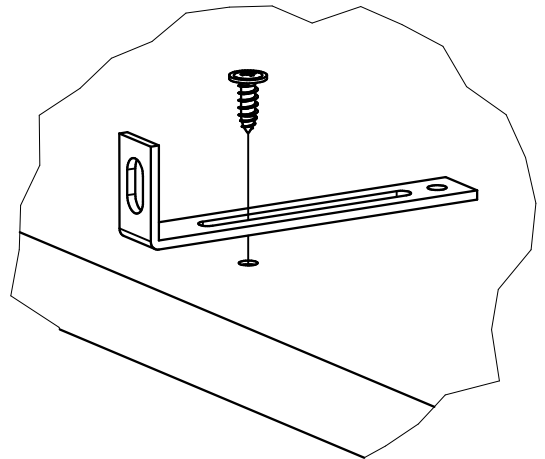

5a / 5b

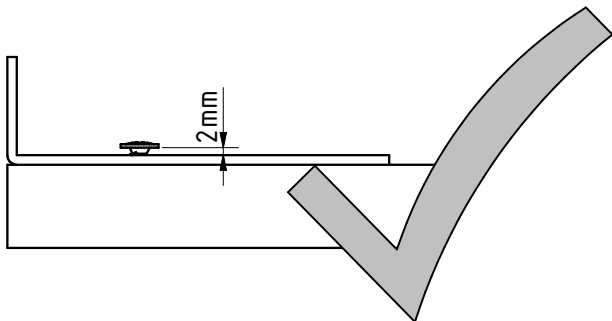
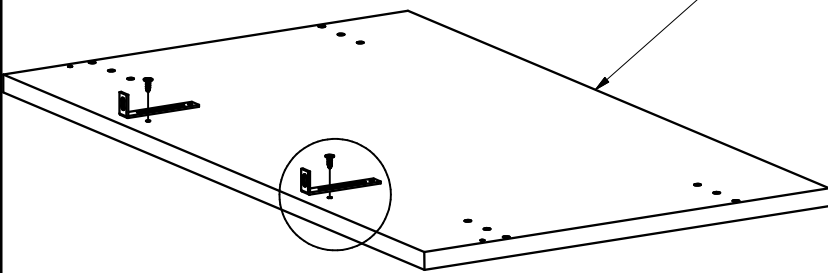

2mm

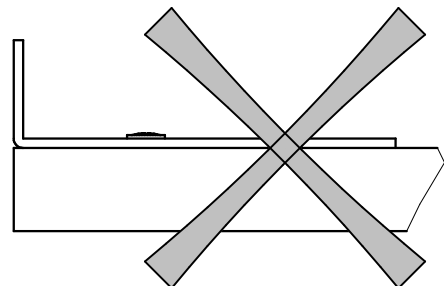

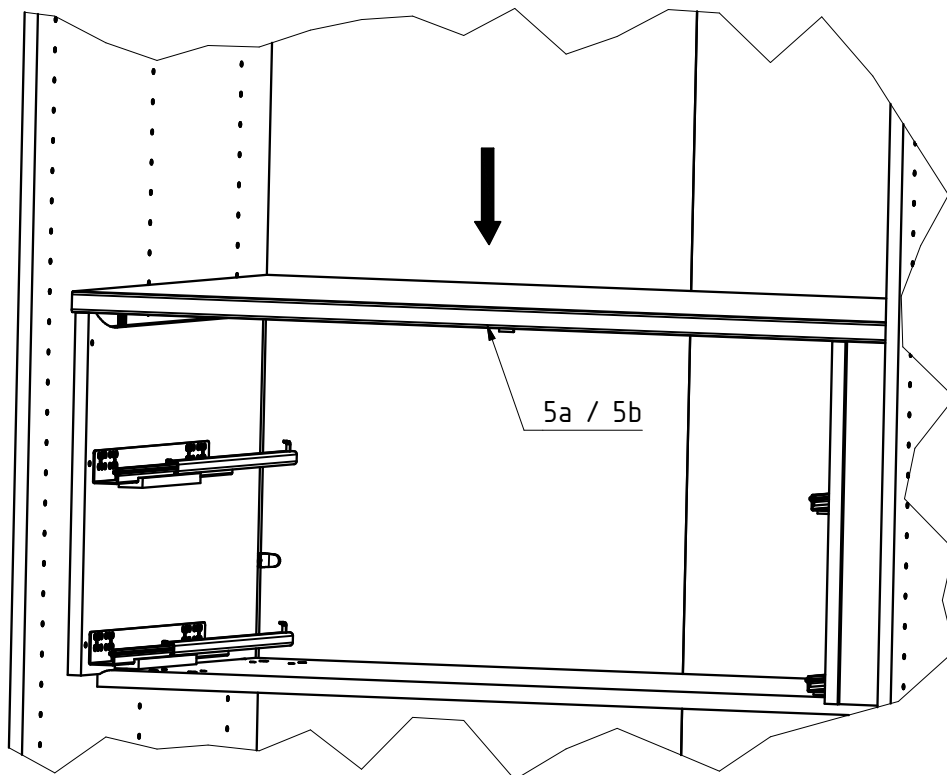
V**W**

4,5x15

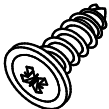

2x 121 098

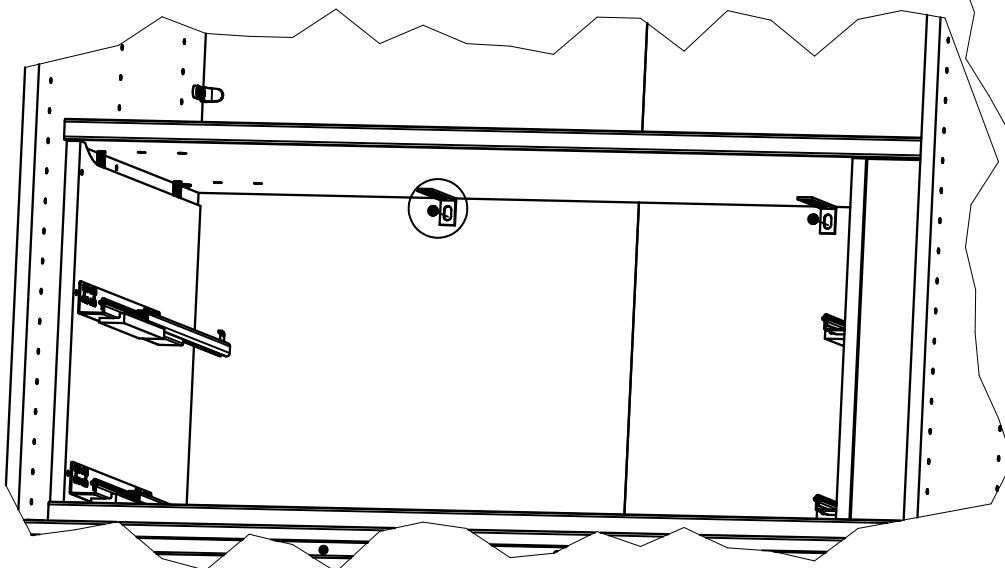
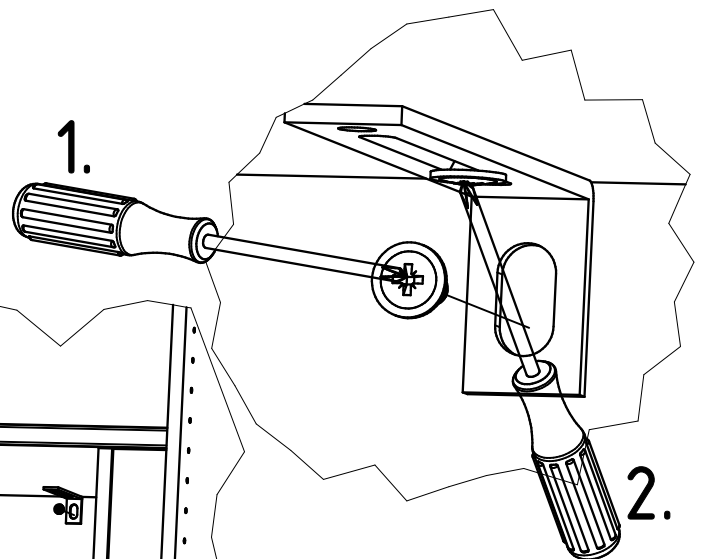

X

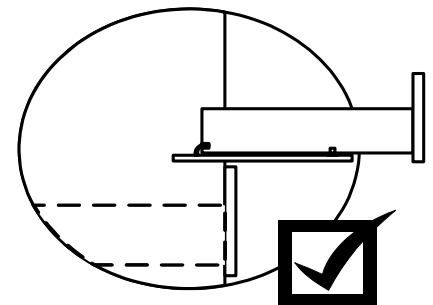
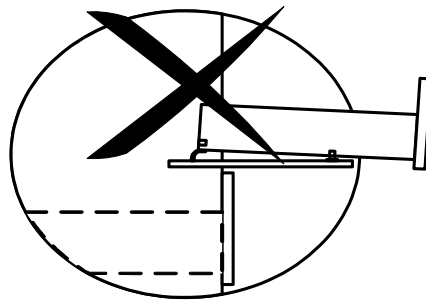
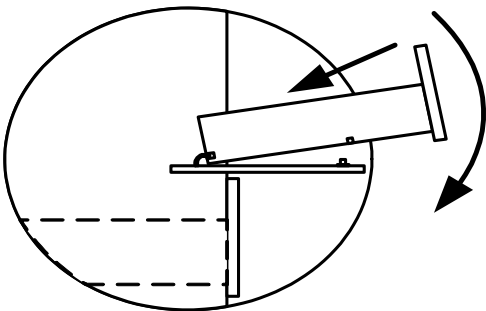
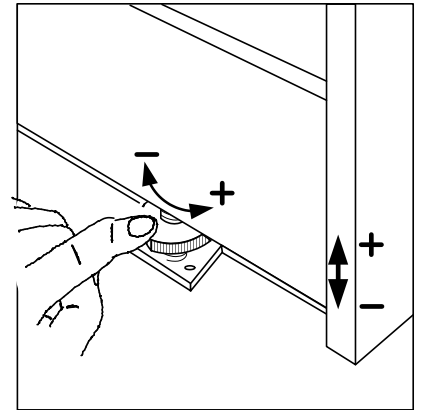
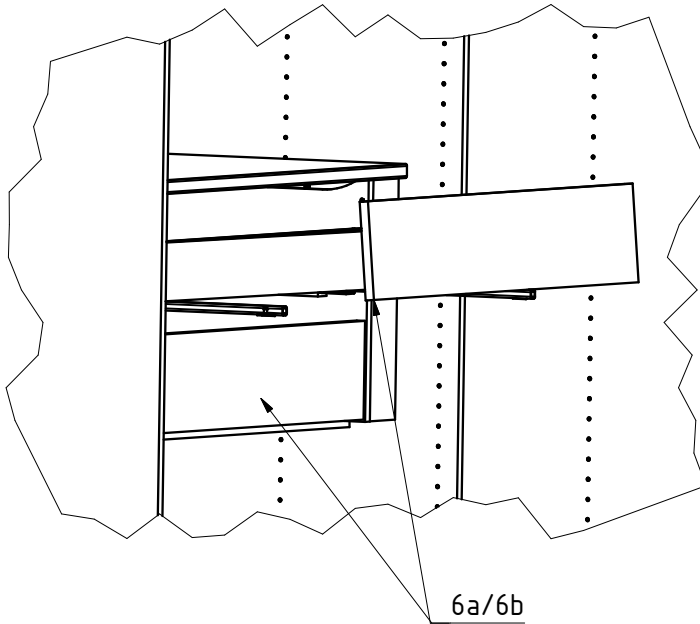

Y

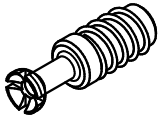

4x 111 229

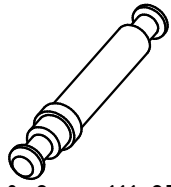

0-2x 111 235

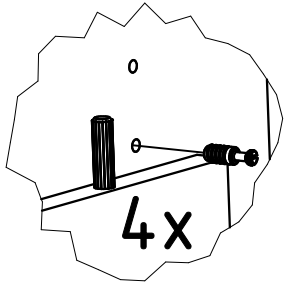

4x

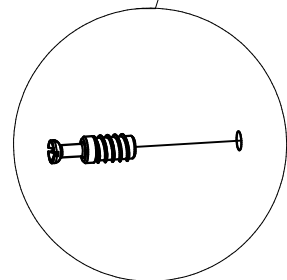
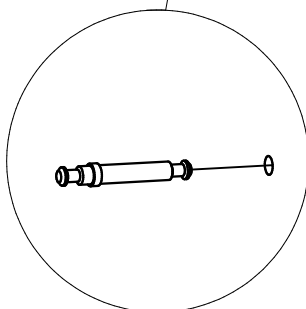
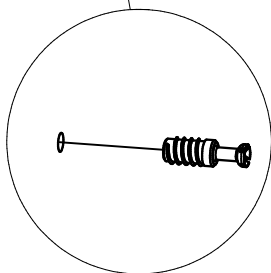
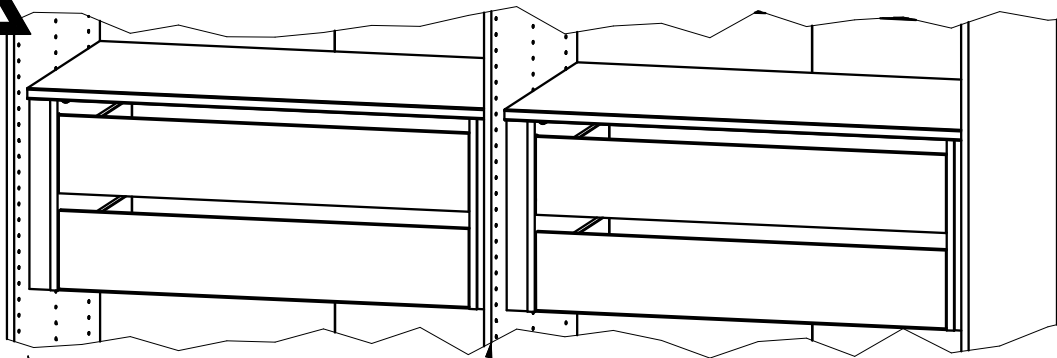
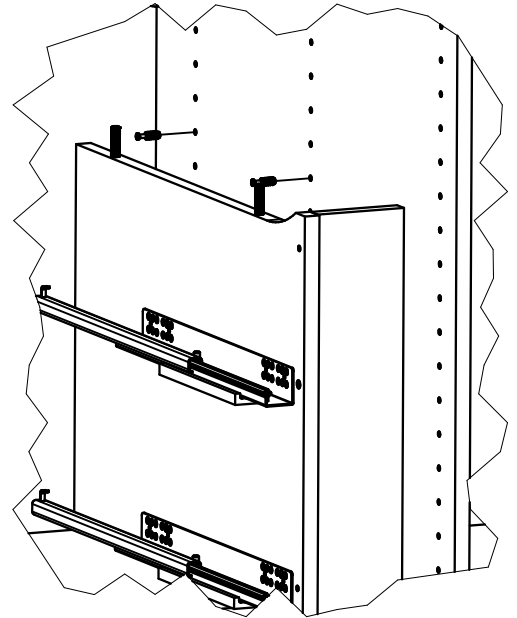
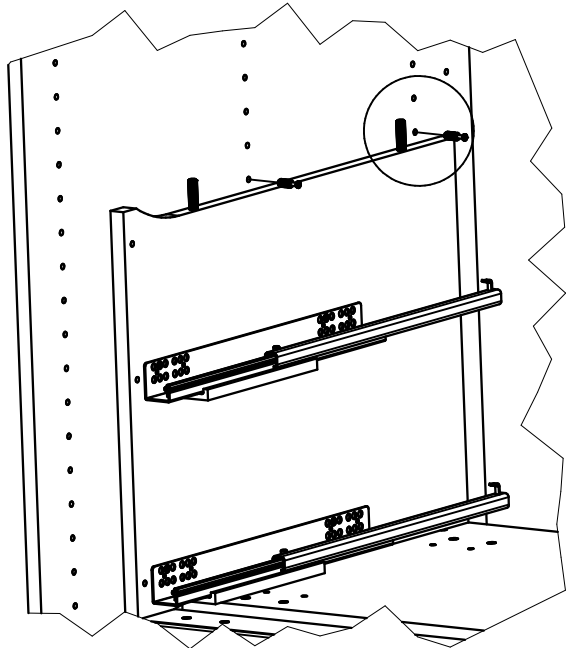
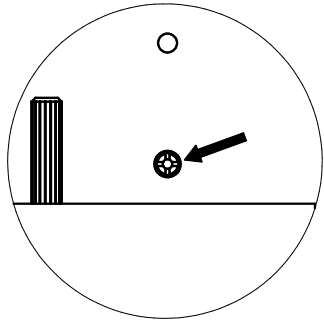

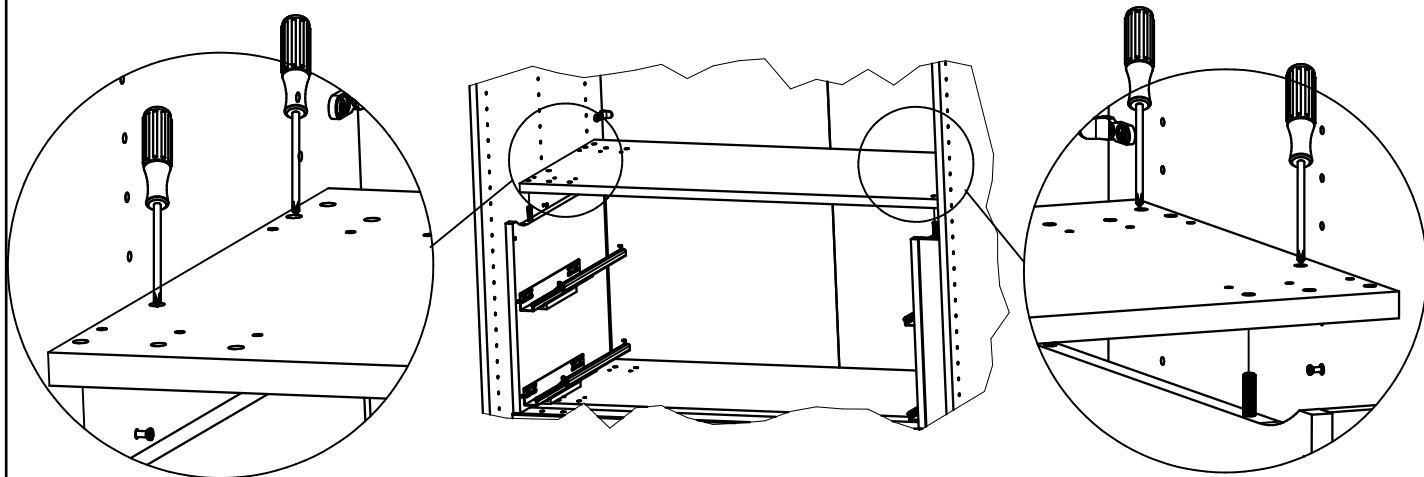
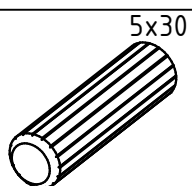
Z**A
A**

2x 353 005

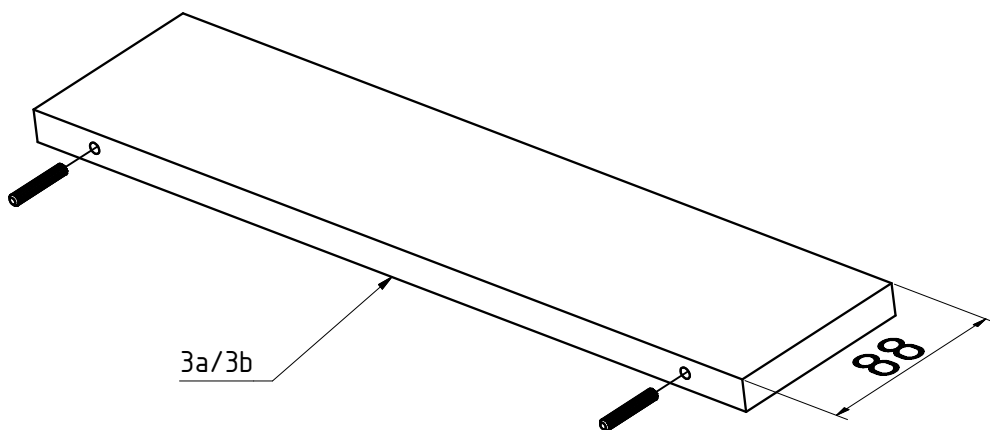
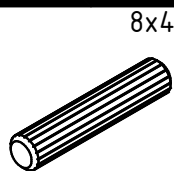
**A
B**

4x 353 007

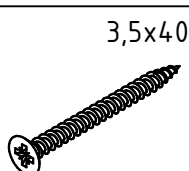

1x 121119

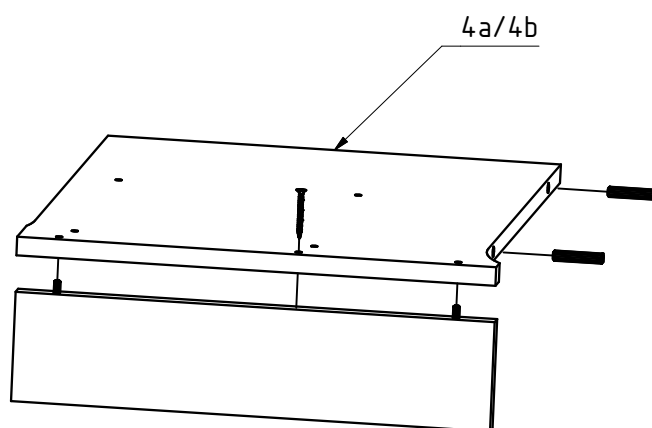
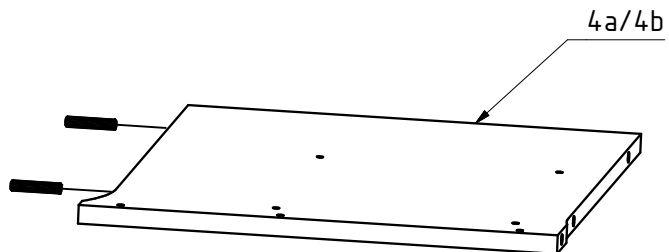

A
C

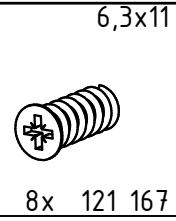
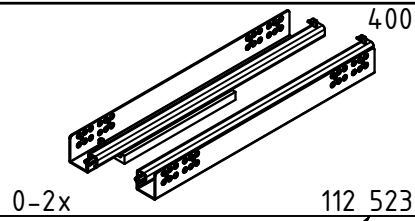
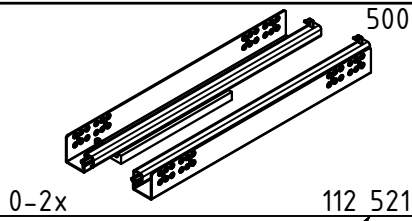

Typ a

Typ b

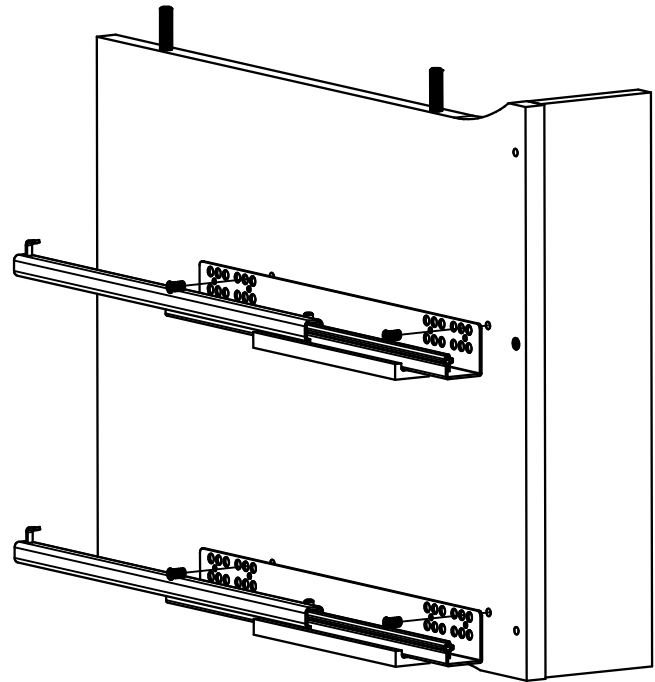
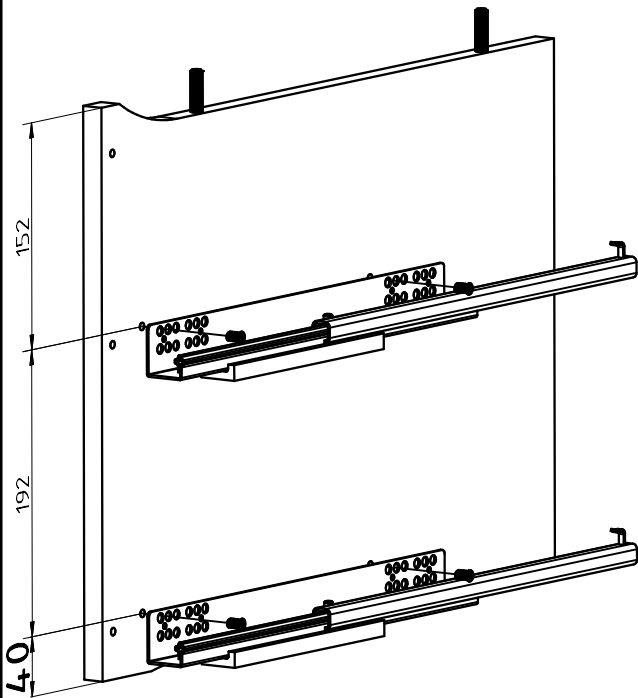
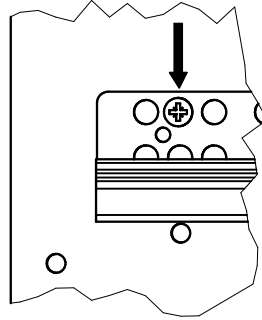

A
D

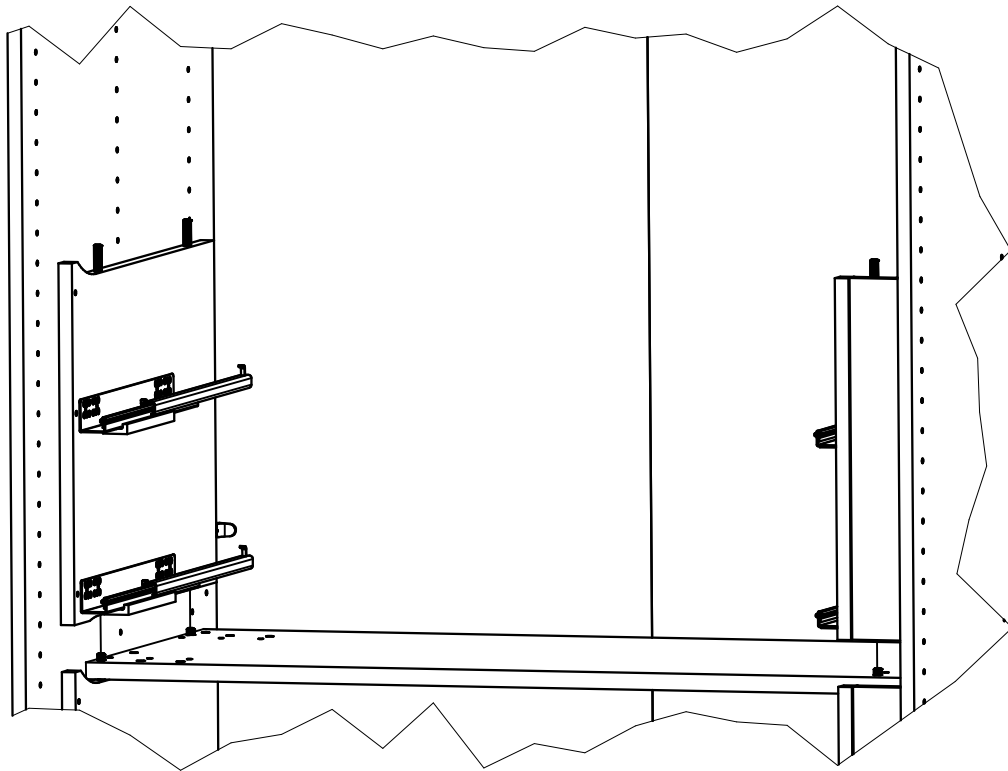

A
E

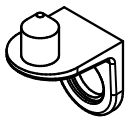

2x 111 049



10x 121 167

6,3x11

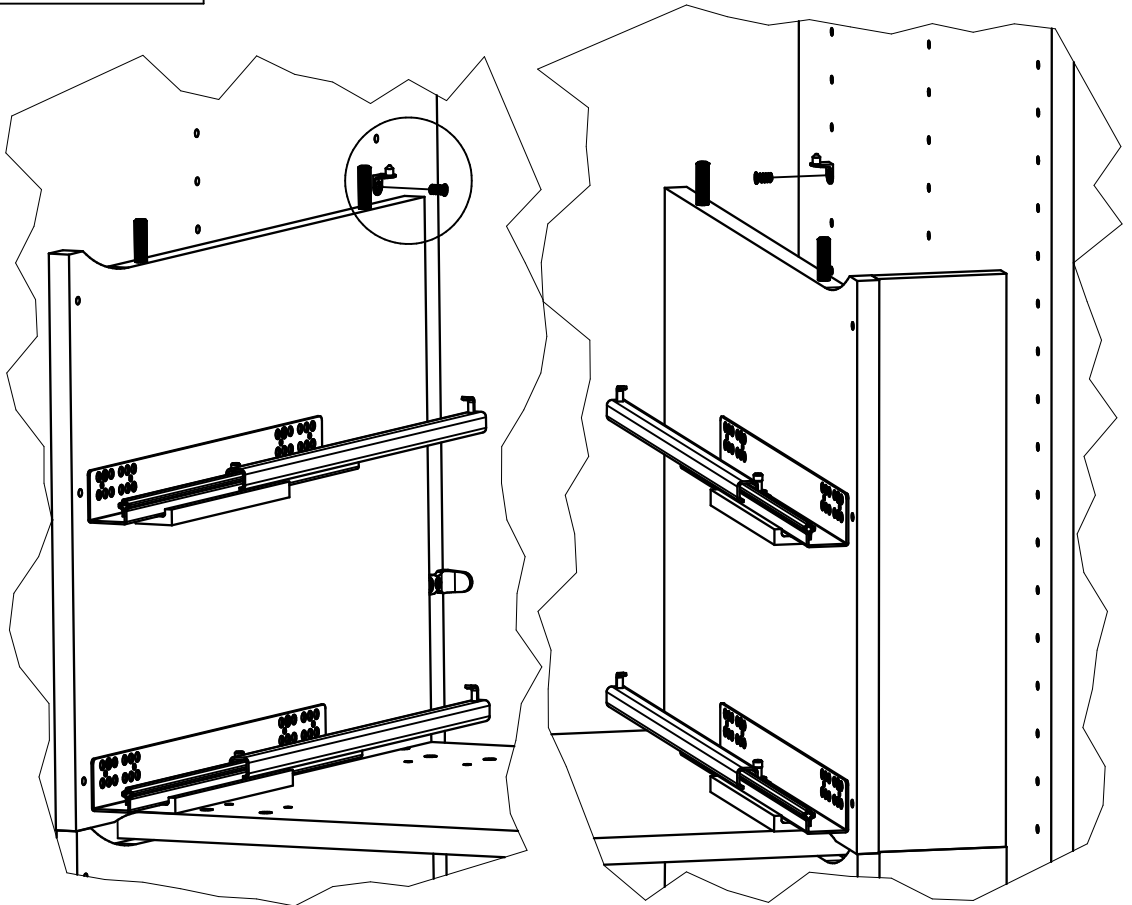
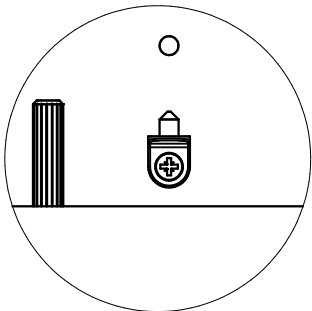
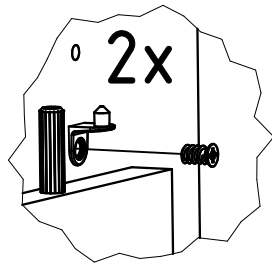

A
F

4,5x15



2x 121 098

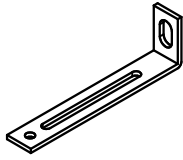

2x 111 036

5a / 5b

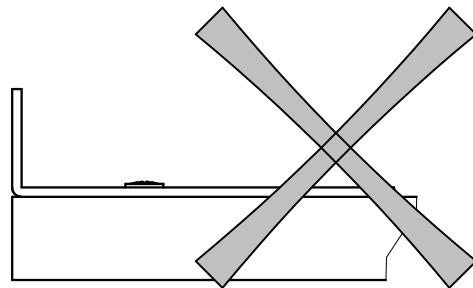
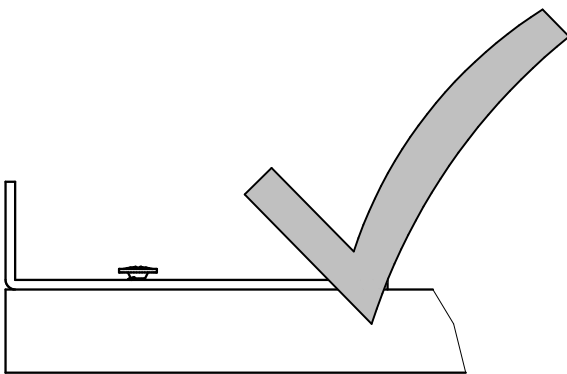
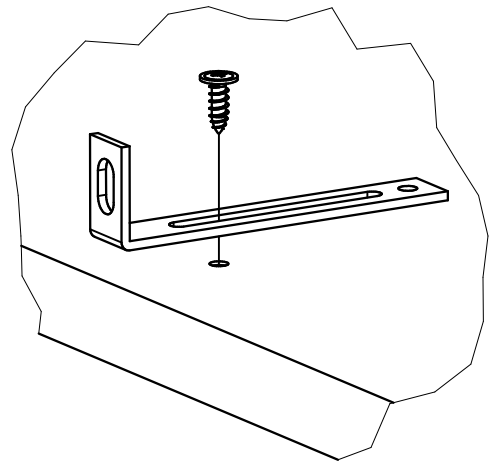
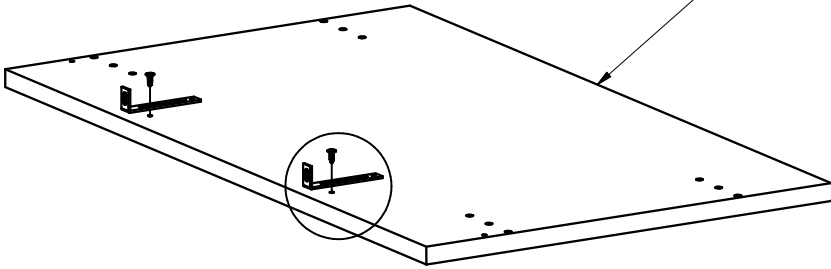

A
G



5a/5b

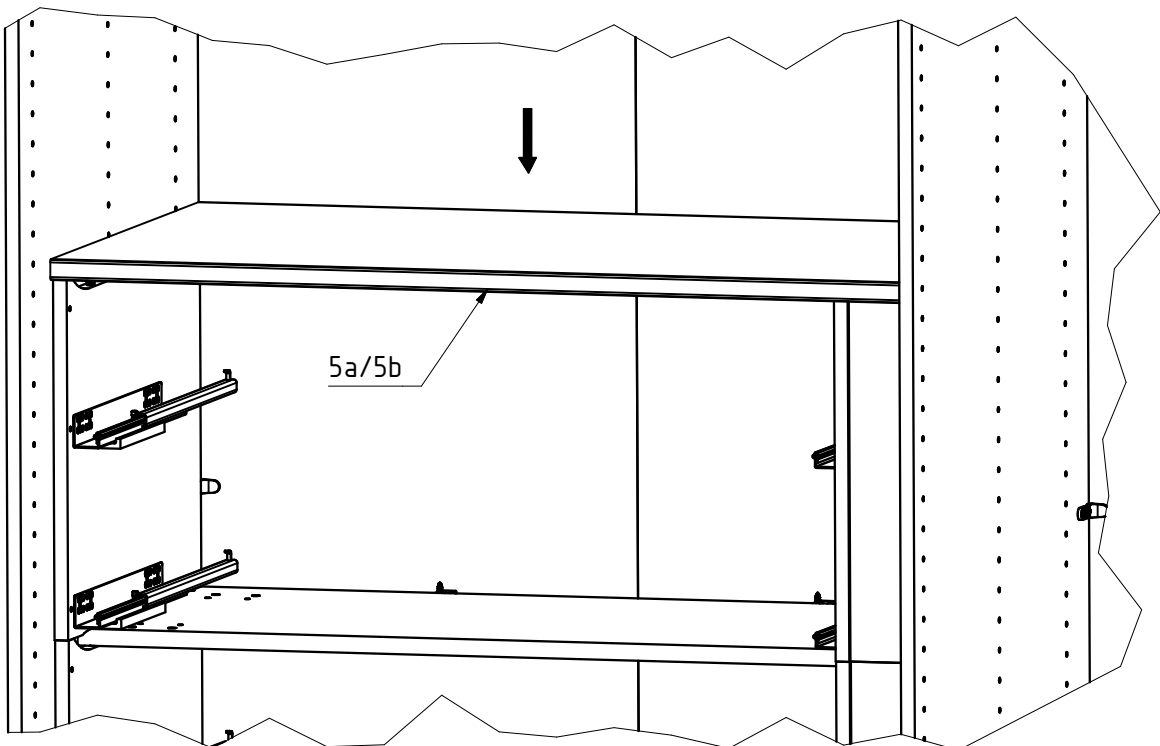

A
H

4,5x15

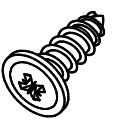



2x 121 098

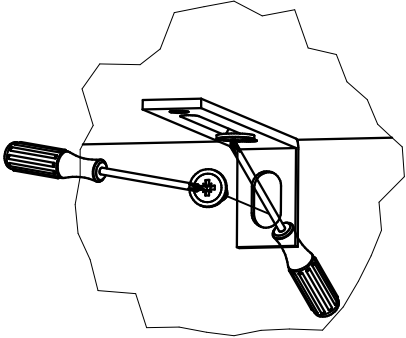
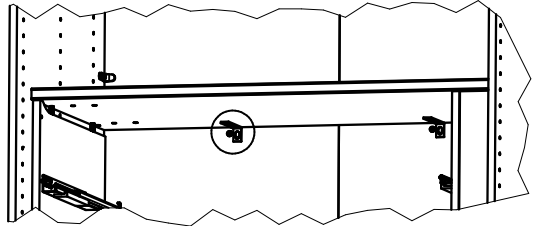

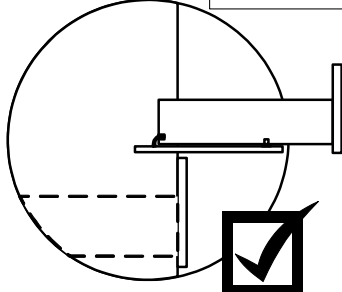
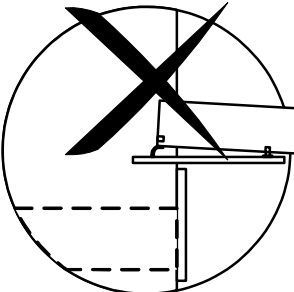
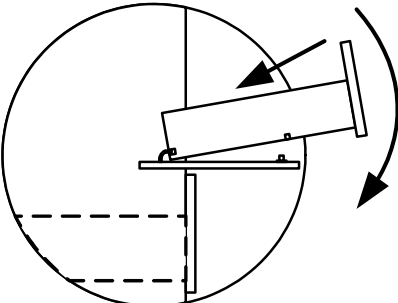
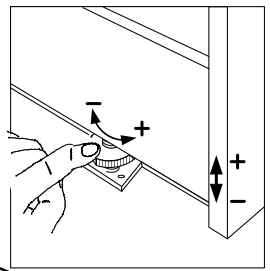
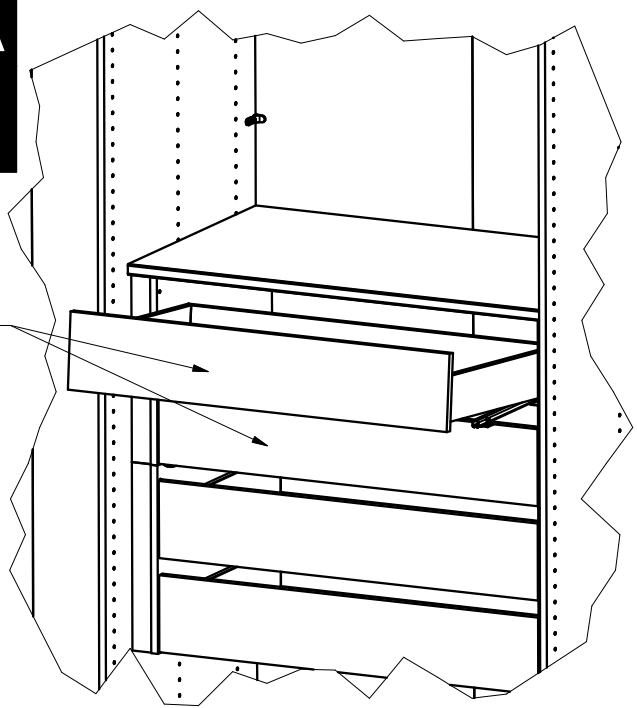

A
I

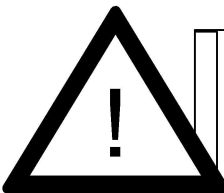

6a / 6b

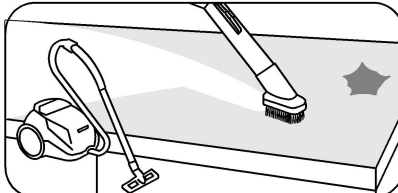
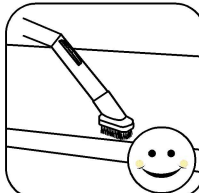
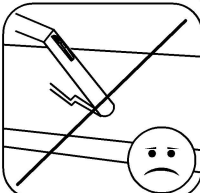
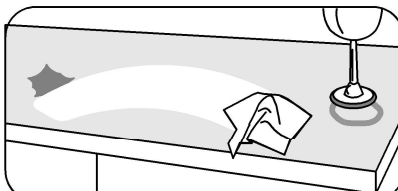
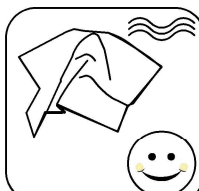

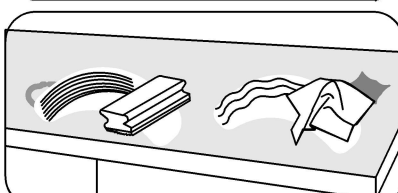

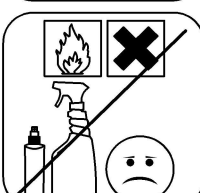
992 122

MONTAGEANLEITUNG INSTRUCTIONS DE MONTAGE ASSEMBLY INSTRUCTIONS MONTAGEAANWIJZING

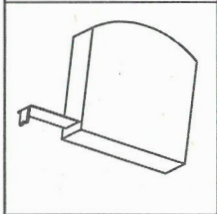
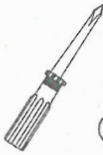
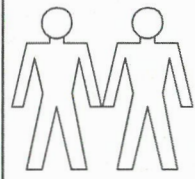

DEU - Beispiel
CZE - příklad
ESP - Ejemplo
FRA - exemple
GBR - example
HUN - példa
ITA - Esempio
NLD - voorbeeld
POL - Przykład
PRT - Exemplo
SVN - primer
ROU - Exemplu
RUS - пример
TUR - Örnek

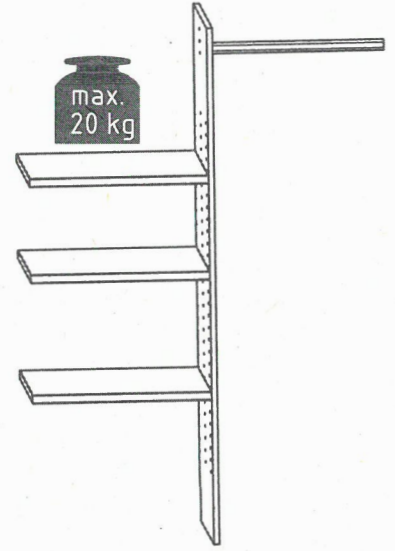
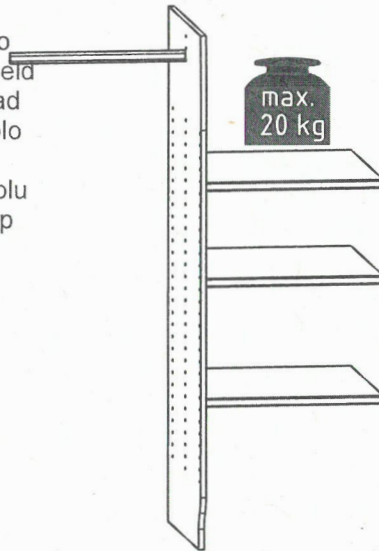

Deutsch - Alle Pakete öffnen und alle Aufbauanleitungen und Sicherheitshinweise lesen. Fachkundige Montage erforderlich. Unsachgemäße Montage kann zu Unfällen führen. Möbel/Gegenstand könnte kippen oder umfallen. **WICHTIG!** Achten Sie darauf, dass Sie Schrauben/Beschläge entsprechend der Wand-/Decken-beschaffenheit und mit ausreichender Tragfähigkeit verwenden. Erkundigen Sie sich ggf. beim Eisenwarenfachhandel.

Français - Ouvrir tous les paquets et lire toutes les instructions de montage et les consignes de sécurité. Montage par un spécialiste nécessaire. Un montage non conforme peut entraîner des accidents. Le meuble/l'objet pourrait basculer ou tomber. **IMPORTANT!** Veuillez à utiliser des vis/ferrures adaptées à la nature du mur/plafond et présentant une capacité de charge suffisante. Le cas échéant, renseignez-vous auprès d'une quincaillerie spécialisée.

Español - Abra todos los paquetes y lea todas las instrucciones de montaje y de seguridad. Se requiere un montaje cualificado. Un montaje incorrecto puede provocar accidentes. El mueble/objeto podría volcar o caerse. ¡**IMPORTANTE!** Asegúrese de utilizar tornillos/herrajes adecuados para la pared/techo y con suficiente capacidad de carga. En caso necesario, infórmese en una ferretería.

Português - Abrir todas as embalagens e ler todas as instruções de montagem e de segurança. É necessária uma montagem competente. Uma montagem incorrecta pode provocar acidentes. O móvel/objeto pode tombar ou cair. **IMPORTANTE!** Certifique-se de que utiliza parafusos/conexões adequados à parede/teito e com capacidade de carga suficiente. Se necessário, informe-se numa loja de ferragens.

Nederlands - Open alle verpakkingen en lees alle montage- en veiligheidsinstructies. Vakkundige montage vereist. Onjuiste montage kan leiden tot ongelukken. Meubels/voorwerpen kunnen kantelen of omvallen. **BELANGRIJK!** Zorg ervoor dat je schroeven/beslag gebruikt die geschikt zijn voor de muur/het plafond en voldoende draagkracht hebben. Informeer indien nodig bij een ijzerhandel.

Magyar - Nyissa ki az összes csomagot, és olvassa el az összes összeszerelési útmutatót és biztonsági utasítást. Szakképzett összeszerelés szükséges. A nem megfelelő összeszerelés balesethez vezethet. A bútortárgy felborulhat vagy eleshet. **FONTOS!** Ügyeljen arra, hogy a falhoz/mennyezethez megfelelő és megfelelő teherbírási csavarokat/szerelvényeket használjon. Szükség esetén érdeklődjön egy barkácsruházban.

Italiano - Aprire tutte le confezioni e leggere tutte le istruzioni di montaggio e di sicurezza. È necessario un montaggio esperto. Un montaggio non corretto può causare incidenti. Il mobile/oggetto potrebbe ribaltarsi o cadere. **IMPORTANTE!** Assicurarsi di utilizzare viti/raccordi adatti alla parete/soffitto e con una capacità di carico sufficiente. Se necessario, rivolgersi a un ferramenta.

Slovensky - Odprite vse pakete in preberite vsa navodila za montažo in varnostna navodila. Potrebno je kvalificirano sestavljanje. Nepravilna montaža lahko privede do nesreč. Pohištvo/predmet se lahko prevrne ali pade. **POMEMBNO!** Prepričajte se, da uporabljate vijake/priključke, ki so primerni za steno/strop in imajo zadostno nosilnost. Po potrebi se pozanimajte v trgovini s strojno opremo.

English - Open all packages and read all assembly instructions and safety instructions. Skilled assembly required. Improper assembly can lead to accidents. Furniture/object could tip or fall over. **IMPORTANT!** Make sure that you use screws/fittings that are suitable for the wall/ceiling and have sufficient load-bearing capacity. If necessary, enquire at a hardware store.

Polski - Otwórz wszystkie opakowania i przeczytaj wszystkie instrukcje montażu i instrukcje bezpieczeństwa. Wymagany jest wykwalifikowany montaż. Nieprawidłowy montaż może prowadzić do wypadków. Meble/przedmioty mogą się przewrócić lub spaść. **WAŻNE!** Upewnij się, że używasz śrub/złączek, które są odpowiednie do ściany/sufitu i mają wystarczającą nośność. W razie potrzeby należy skontaktować się ze sklepem z narzędziami.

Türkçe - Tüm paketleri açın ve tüm montaj talimatlarını ve güvenlik talimatlarını okuyun. Nitelikli montaj gereklidir. Yanlış montaj kazalara yol açabilir. Mobilya/nesne devrilebilir veya düşebilir. **ÖNEMLİ!** Duvara/tavana uygun ve yeterli yük taşıma kapasitesine sahip vidalar/ bağlantı parçaları kullandığınızdan emin olun. Gerekirse bir hirdavatçıdan bilgi alın.



Česky - Otevřete všechna balení a přečtěte si všechny montážní a bezpečnostní pokyny. Je nutná kvalifikovaná montáž. Nesprávná montáž může vést k nehodám. Nábytek/předmět by se mohl převrátit nebo spadnout. **DŮLEŽITÉ!** Dbejte na to, abyste použili šrouby/kování, které jsou vhodné pro stěnu/strop a mají dostatečnou nosnost. V případě potřeby se informujte v železářství.

Русский - Вскройте все упаковки и ознакомьтесь со всеми инструкциями по сборке и правилами техники безопасности. Требуется квалифицированная сборка. Неправильная сборка может привести к несчастным случаям. Мебель/предмет может опрокинуться или упасть. **ВАЖНО!** Убедитесь, что используемые винты/фурнитура подходят для стены/потолка и обладают достаточной несущей способностью. При необходимости обратитесь в хозяйственный магазин.

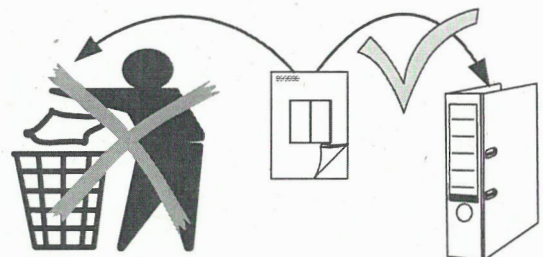
Română - Deschideți toate ambalajele și citiți toate instrucțiunile de asamblare și instrucțiunile de siguranță. Este necesară o asamblare calificată. O asamblare necorespunzătoare poate duce la accidente. Mobilă/obiectul s-ar putea răsturna sau cădea. **IMPORTANT!** Asigurați-vă că folosiți șuruburi/fitinguri adecvate pentru perete/plafon și că au o capacitate portantă suficientă. Dacă este necesar, interesați-vă la un magazin de feronerie.

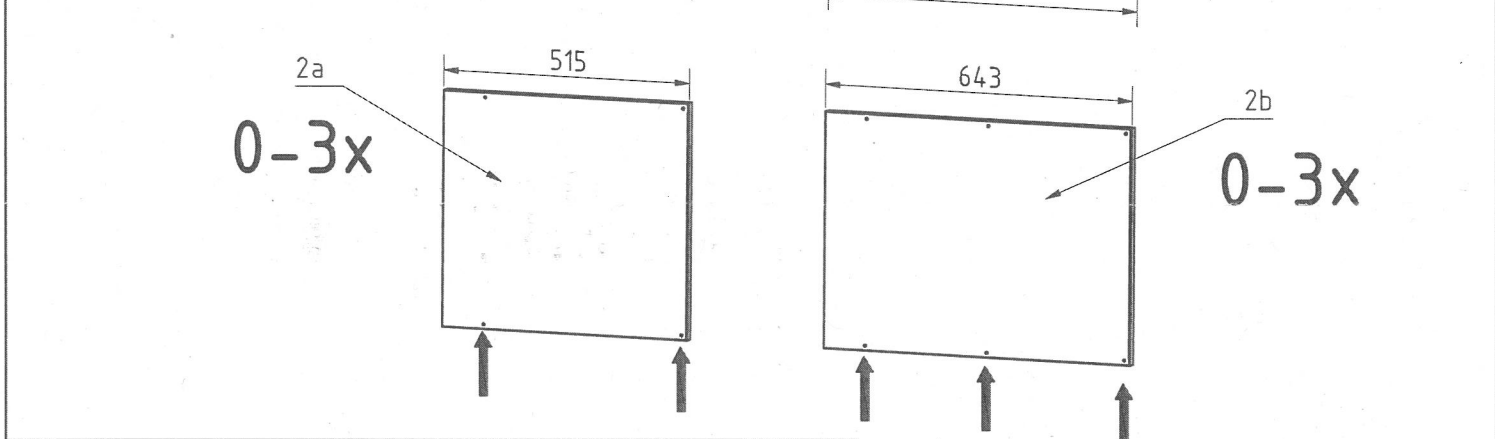
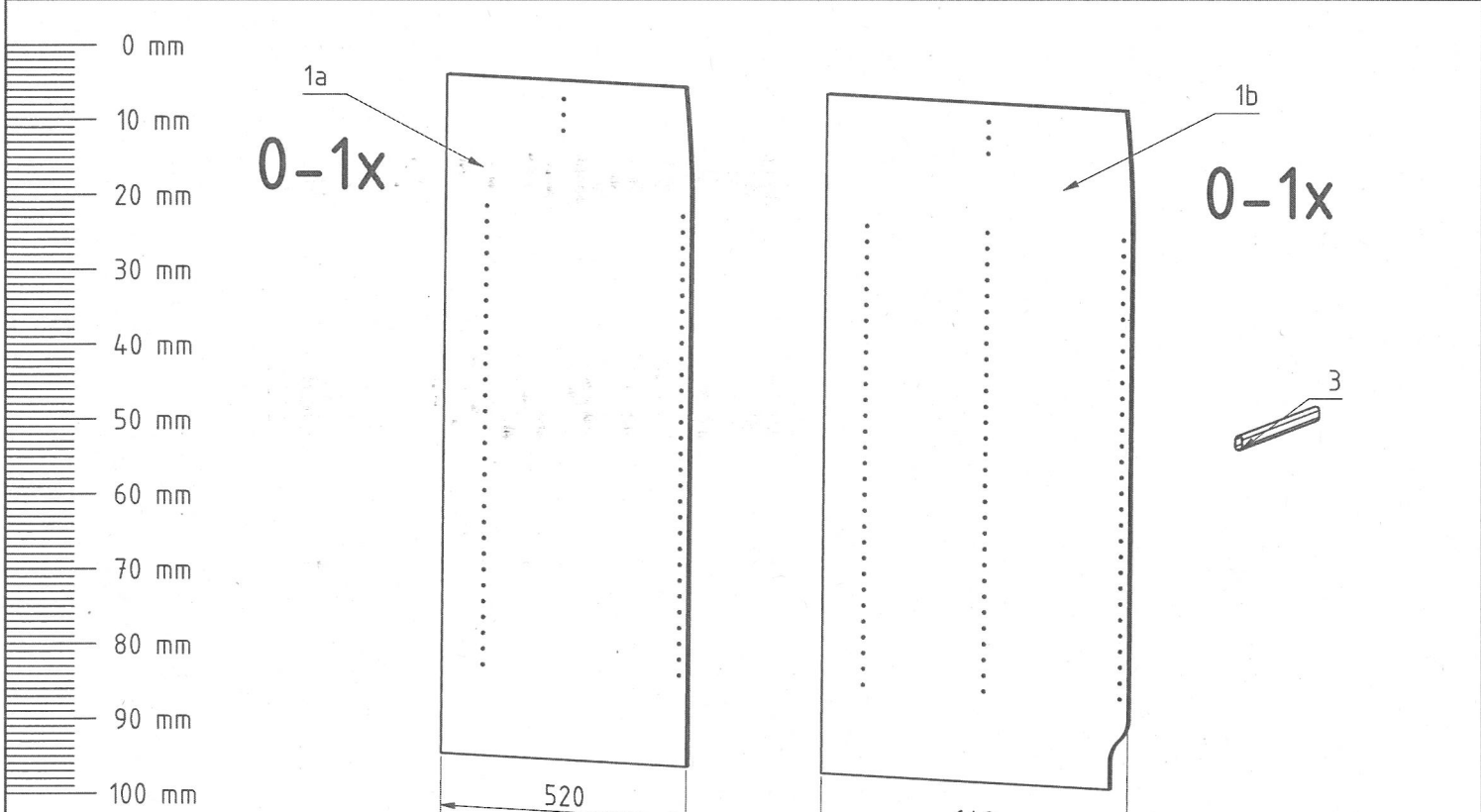

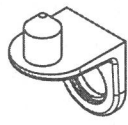

6,3x11  12-18x 121 167	 12-18x 111 049	3,5x15  2x 121 370	 2x 117 002
--	---	---	---



A

6,3x11



6-9x 121 167

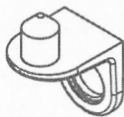

6-9x 111 049

3,5x15



1x 121 370



1x 117 002



520mm -> 6x 121167+111049

648mm -> 9x 121167+111049

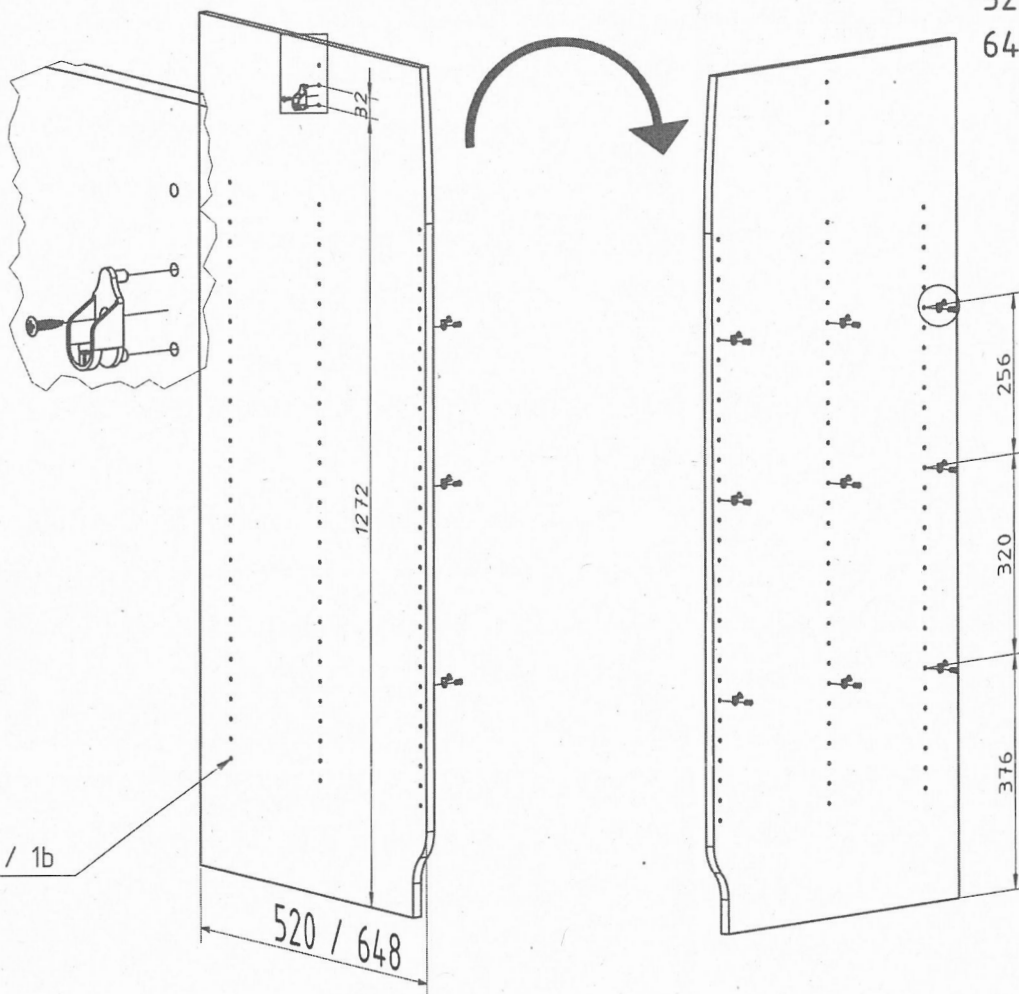

1a / 1b

520 / 648

1272

B2

256

320

376

B

6,3x11



6-9x 121 167

3,5x15



1x 121 370

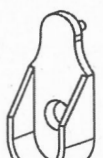

1x 117 002

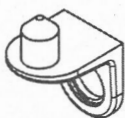

6-9x 111 049

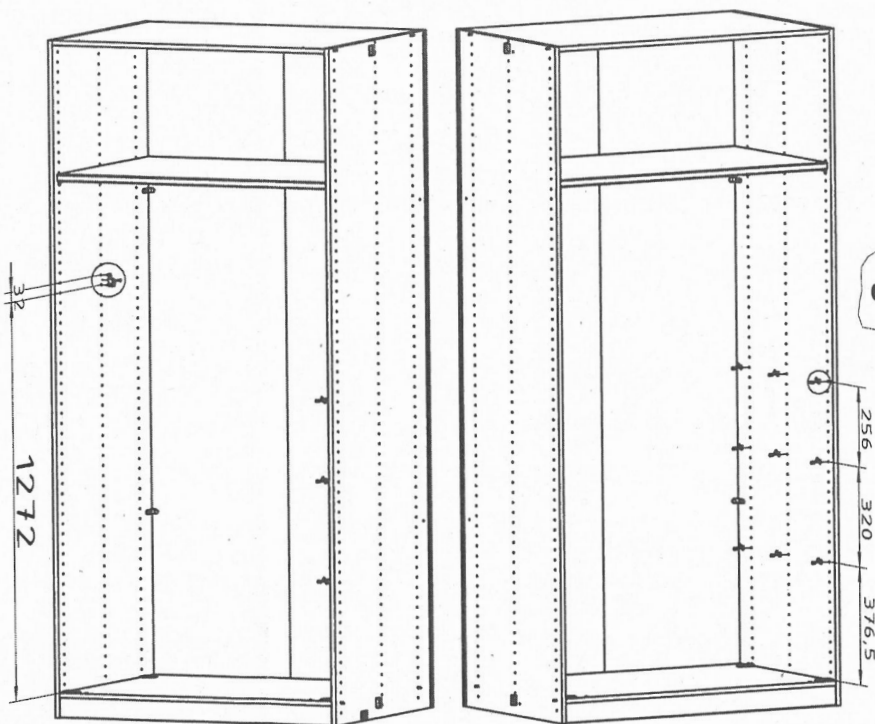

35

1272

256

320

376,5

C

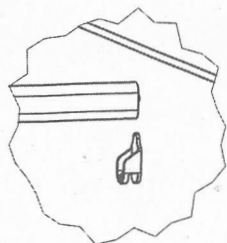

3

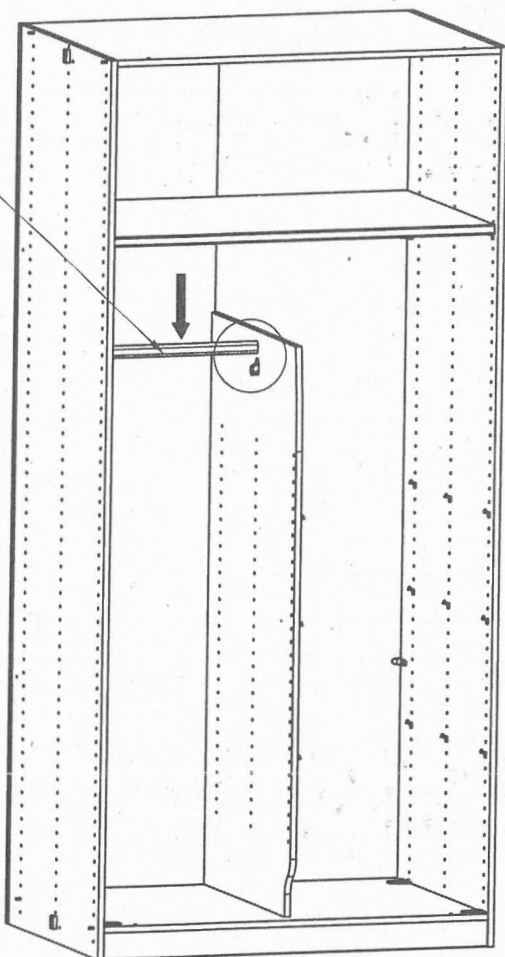

D

max.
20 kg

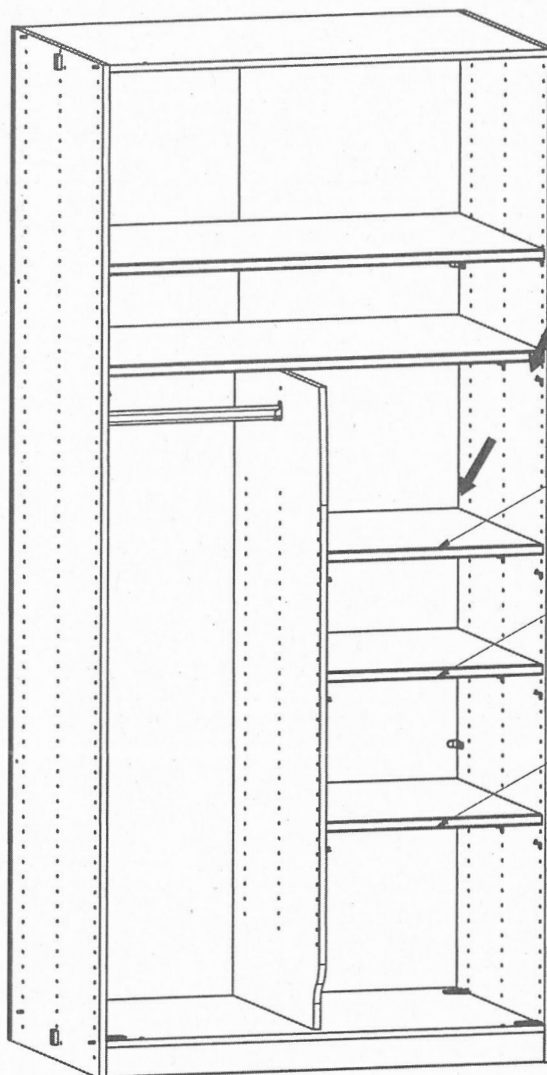

2a / 2b

2a / 2b

2a / 2b

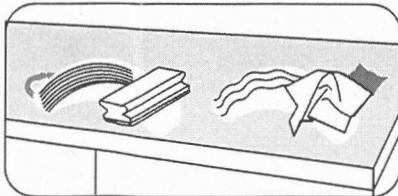
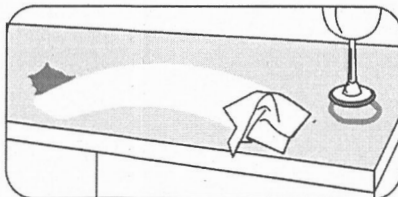
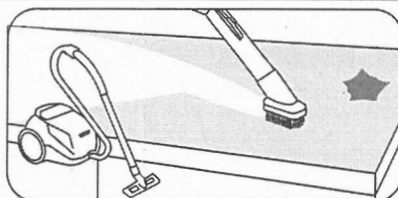

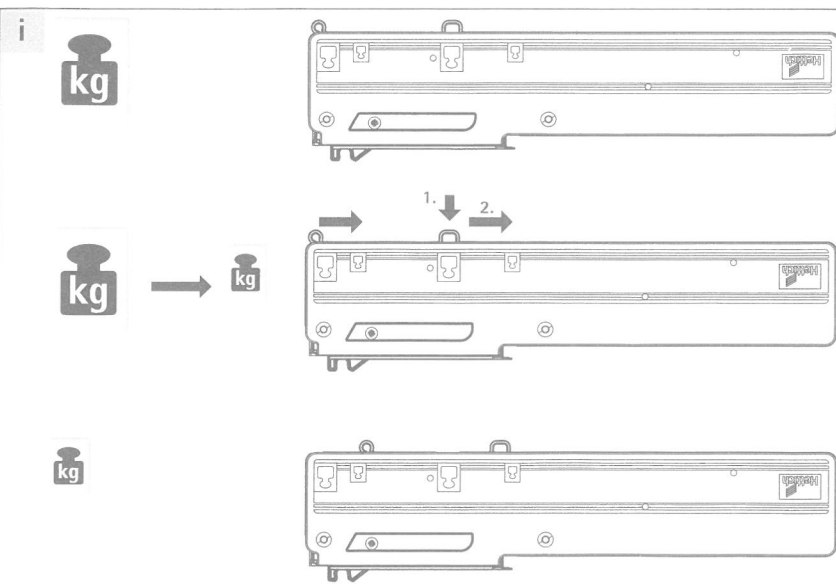
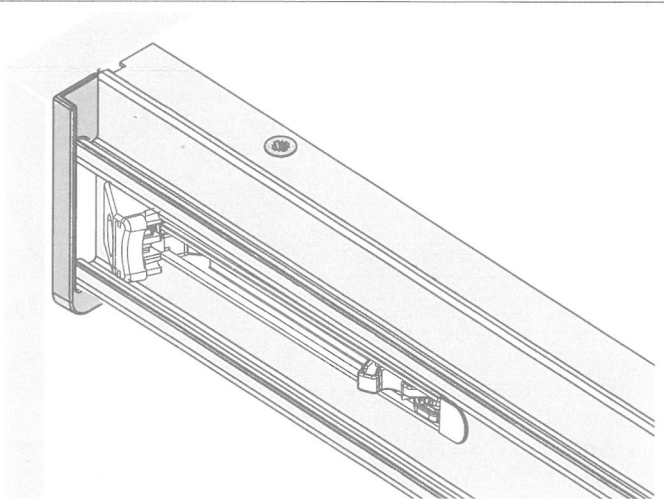
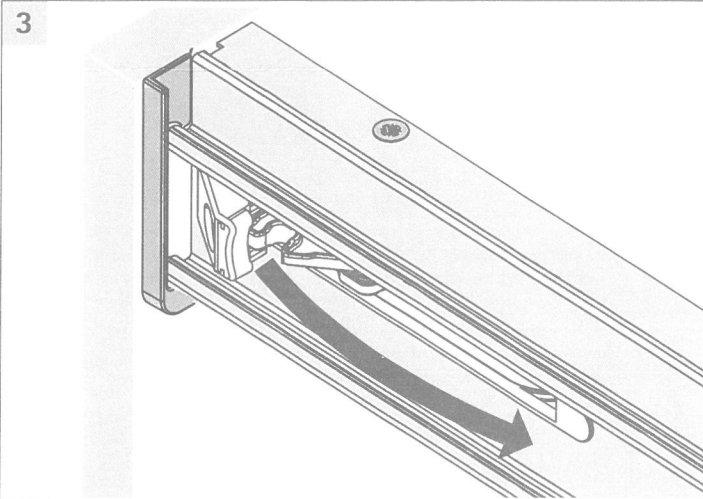
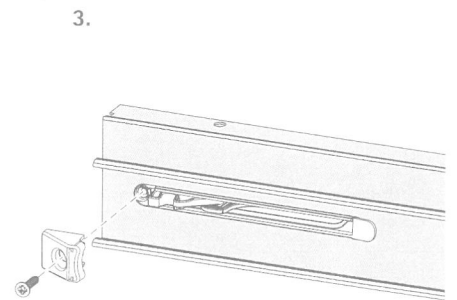
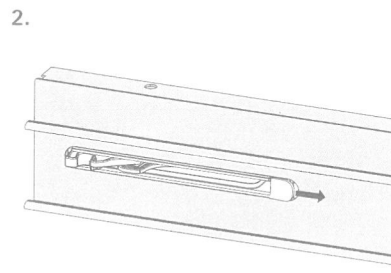
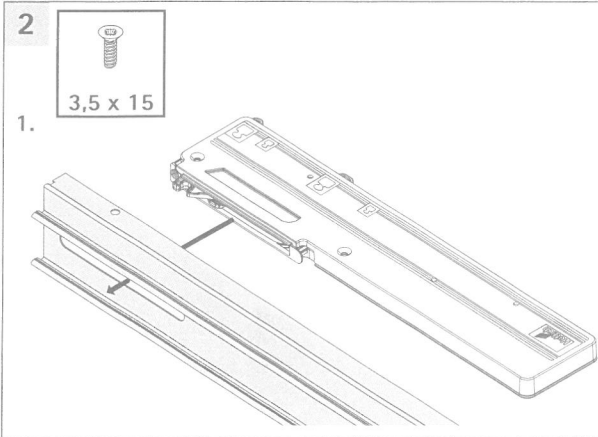
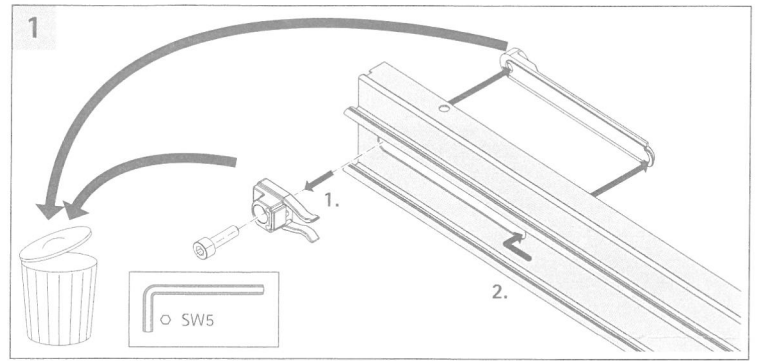
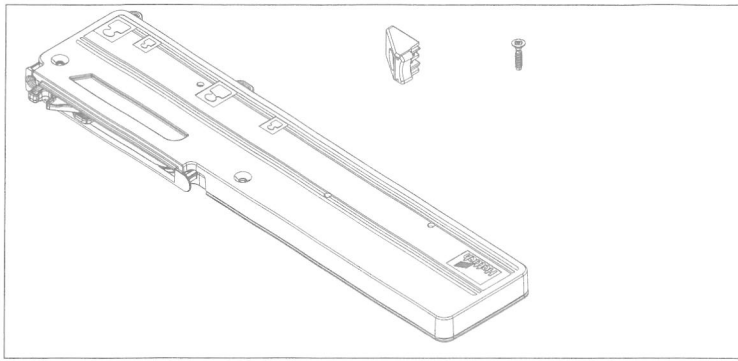

Bremskraft
Brake force
Force de freinage
Remkracht
Сила торможения

Schließkraft
Closing force
Force de fermeture
Sluitkracht
Сила закрывания

