

# TEAM 7

Dokument für  
die qualifizierte  
Fachkraft!



## Montagehandbuch

# Kids

## Korpussystem

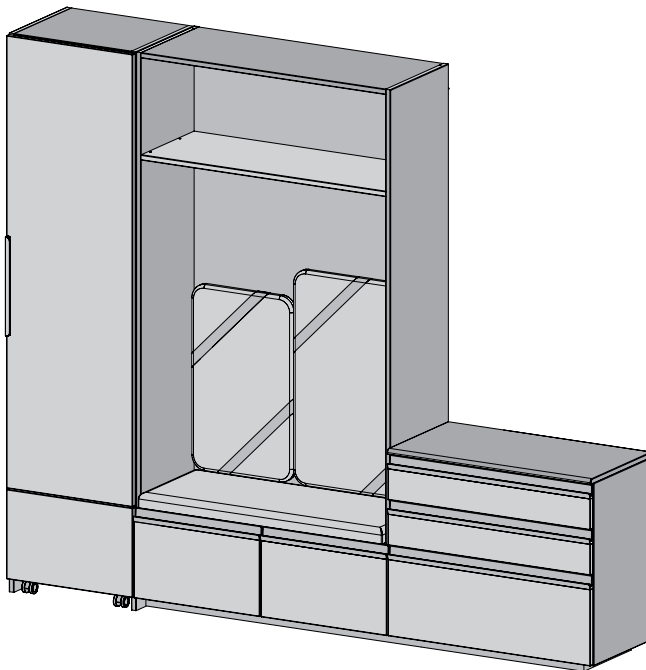

# DE

122022  
TD284010A

Nach der Montage  
zur Aufbewahrung für  
unsere Kunden!

## ! RAUMKLIMA

- Ideales Raumklima für Menschen, Pflanzen und Naturholzmöbel ist:

**rel. Luftfeuchtigkeit: 40 bis 60% und eine  
Raumtemperatur: 18° bis 23° Celsius.**

- Bei längeren Über- bzw. Unterschreitungen dieser Werte kommt es zu Schwind- bzw. Quellvorgängen. In Folge können Verzug, Risse, offene Leimfugen und raue Oberflächen auftreten.

## ! PFLEGE

- Pflegeanleitungen (Naturholz-, Leder-, Stoff-, Stricktex-, Stein-, Glas-, Filz-, Keramik-, Metall-, und Arbeitsplattenpflege) entnehmen Sie bitte der TEAM 7 Homepage.

- Wichtige produkt- und warentypische Eigenschaften der TEAM 7 Naturholzmöbel finden Sie auch in unserem Service- und Gütepass unter:

<https://www.team7-home.com/at/de/service/service-und-guetepass/>



## ! DOKUMENTATION

- Bewahren Sie alle Unterlagen zum Kauf Ihres Möbelstücks, auch über die gesetzliche Gewährleistungspflicht von zwei Jahren, sorgsam auf.
- Wenn Sie Ersatz- oder Ergänzungsstücke benötigen, erleichtern Ihnen die Kaufunterlagen die genaue Auskunft über das von Ihnen erworbene Produkt.
- Bei Transportschäden Ihres Möbelstücks, sind Fotos des beschädigten Teils in der Originalverpackung zwingend notwendig.

## ! ACHTUNG

- Beiliegendes Wandbefestigungs- Material eignet sich nur für Beton-, Vollziegel- und Hochlochziegel\*-Wände. Für andere Wandtypen müssen Spezialdübel verwendet werden.

\* bei Hochlochziegel ohne Schlag bohren!

- Dabei ist vom Fachmann die Eignung des Untergrundes zu prüfen und zu kontrollieren, ob die Befestigungsmittel den auftretenden Kräften standhalten! Gegebenenfalls sind andere, der Wandbeschaffenheit entsprechende Befestigungsmittel zu wählen!
- Wird dieser Sicherheitshinweis nicht durchgeführt, übernimmt TEAM 7 keine Produkthaftung!

## ! ACHTUNG

- Alle elektrischen Arbeiten sind von einer entsprechenden Fachkraft durchzuführen!
- Öffnen sie niemals ein Netzgerät. Es besteht Lebensgefahr!
- Die Summe der Wattanzahl der Spots, darf die Wattleistung des Trafos, beziehungsweise der Funkeinheit nicht übersteigen.
- Wenn kein Kabeldurchlass vorgesehen ist, mit Stichsäge einschneiden.

# Inhaltsverzeichnis

<b>1.</b>	<b>Raum-/ Planungskontrolle</b>	<b>5</b>
<b>2.</b>	<b>Typenübersicht</b>	<b>6-7</b>
<b>3.</b>	<b>Korpus Zusammenbau</b>	<b>8-13</b>
<b>4.</b>	<b>Korpusverbindungsmöglichkeiten</b>	<b>14</b>
4.1	Korpusse verbinden	14
4.2	Aufsatzkorpus	14
<b>5.</b>	<b>Sockelmontage</b>	<b>15-17</b>
5.1	Rückspringender Sockel	15
5.2	Sockelmontage bei wenig Platz	15-16
5.3	Ausrichten	16
5.4	Rolladenkorpus: Höhensteller	17
<b>6.</b>	<b>Platzierung</b>	<b>17-18</b>
<b>7.</b>	<b>Kippsicherung</b>	<b>19-21</b>
7.1	Montage Kippsicherung	19-20
7.2	Kippsicherung Rolladenkorpus	20
7.3	Kippsicherung Betttruhe	21
<b>8.</b>	<b>Montage Hängebeschlag</b>	<b>21-22</b>
7.1	Montage Hängebeschlag	21
7.2	Korpus einhängen und ausrichten	22
7.3	Beschlagseinstellungen	22
<b>9.</b>	<b>Seitenblenden- und Deckplattenmontage</b>	<b>23-24</b>
9.1	Seitenblende	23
9.2	Deckplatten verbinden	23
9.3	Deckplatte montieren	24
<b>10.</b>	<b>Rollen montieren</b>	<b>24</b>
<b>11.</b>	<b>Frontkomponenten</b>	<b>25-28</b>
11.1	Lade	25
11.2	Klappe	26
11.3	Drehtür	26
11.4	Rolllade	27-28
11.5	Wandpaneel	28
11.6	Licht ein- und ausschalten	29
<b>12.</b>	<b>Inneneinteilungen</b>	<b>29-31</b>
12.1	T-Einteilung	29
12.2	Kleiderstange	30
12.3	Fach mit Kleiderstange	30
12.4	Sicherheitsfach	31

# Werkzeuge

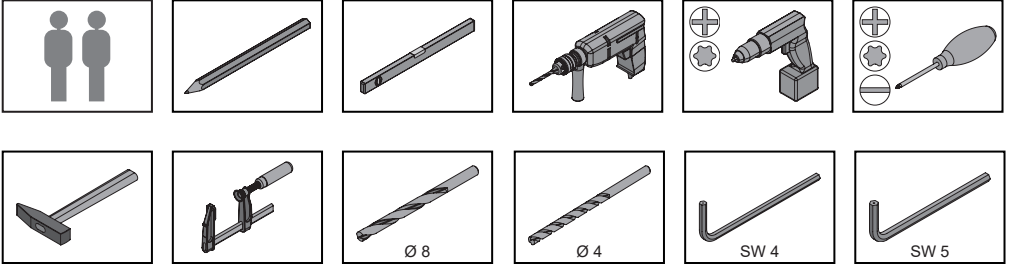

# Beschläge

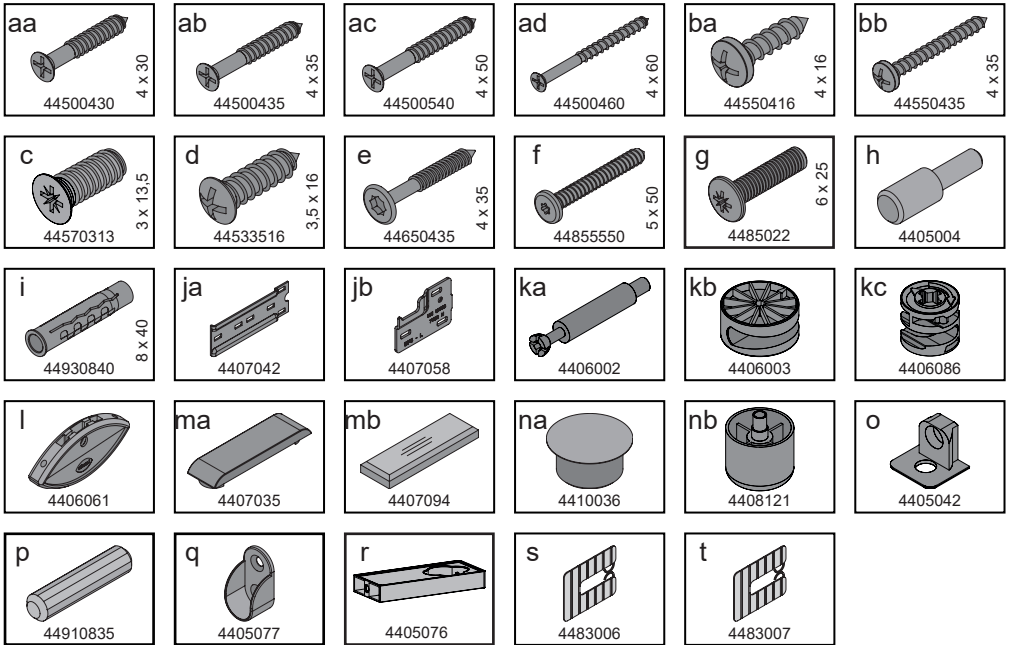

# 1. Raum- / und Planungskontrolle

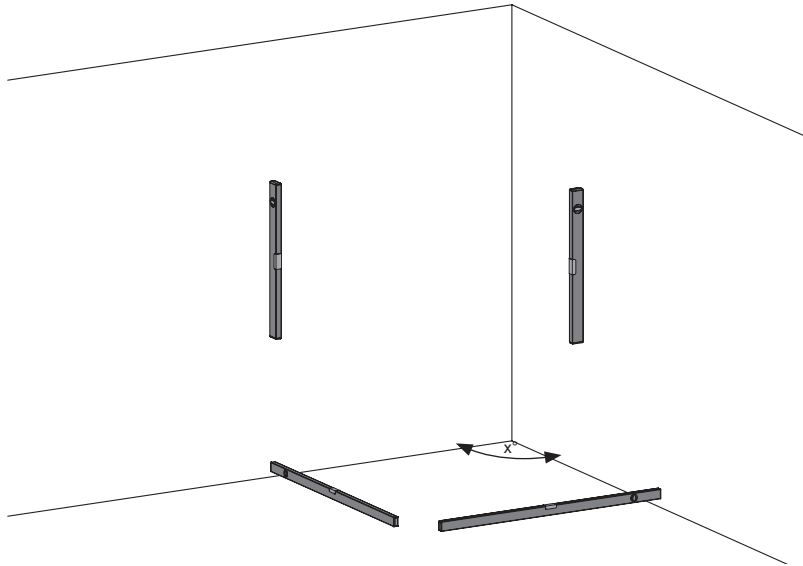

Notizen

.....

.....

.....

.....

.....

.....

## 2. Typenübersicht

### Basiskorpus

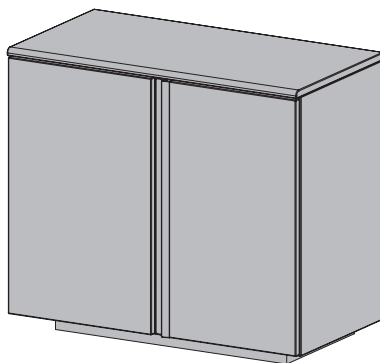
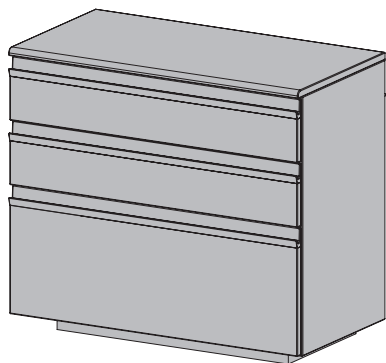

### Plattformkorpus

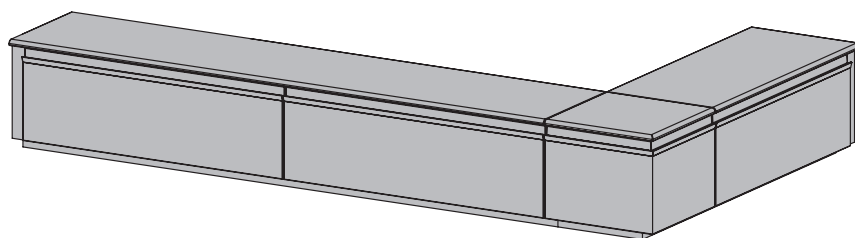

### Betttruhe

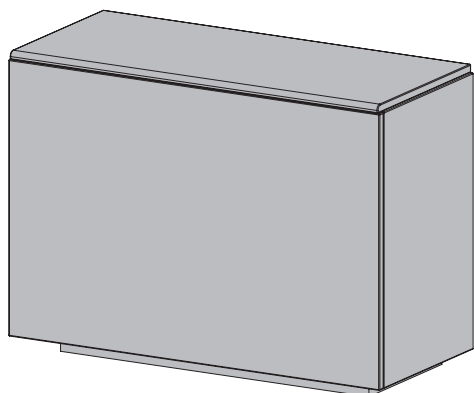

## Sitznische

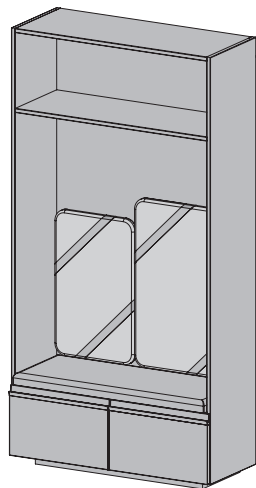

## Rolladenkorpus

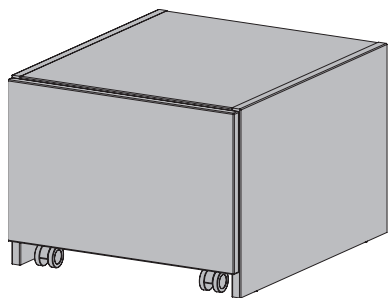

## Rollcontainer

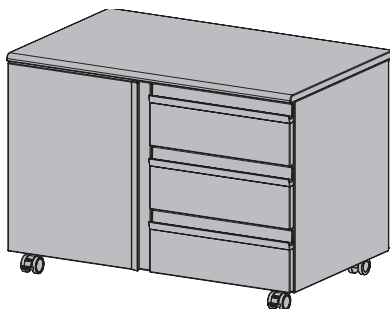
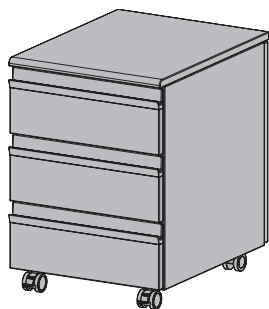

### 3. Optional: Korpus Zusammenbau

#### 3.1 Korpus zerlegt

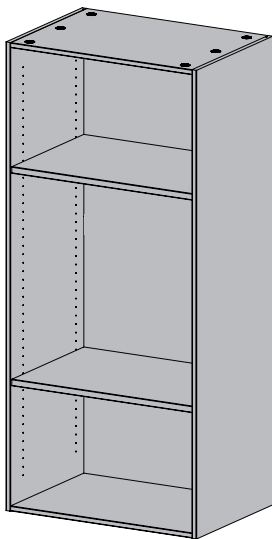

#### 3.2 Bolzen einschrauben

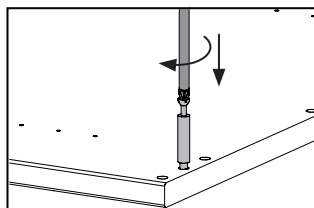
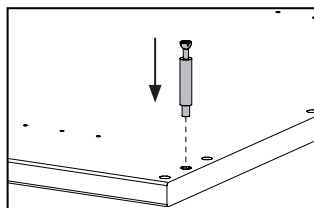
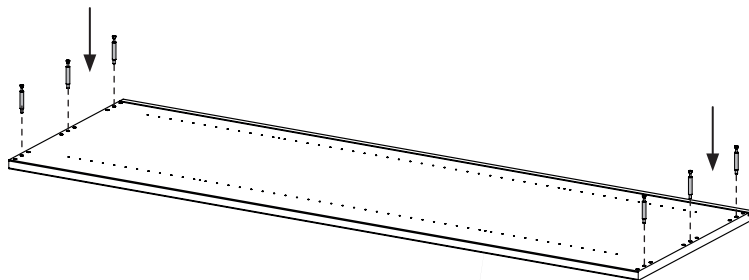
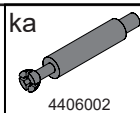



### 3.3 Gehäuse eindrücken

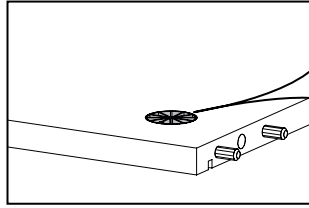
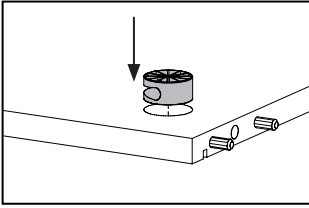
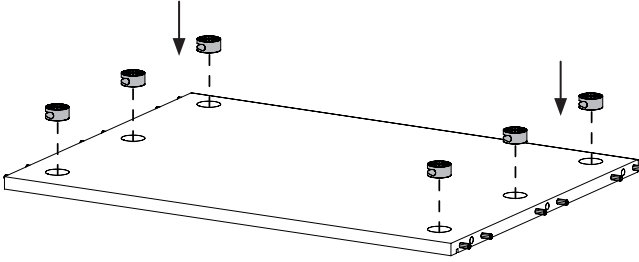
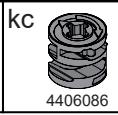
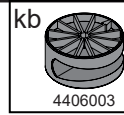

### 3.4 Ober- und Unterboden befestigen

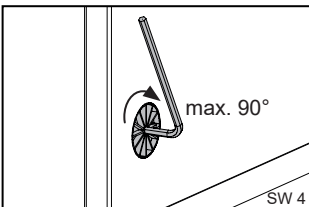
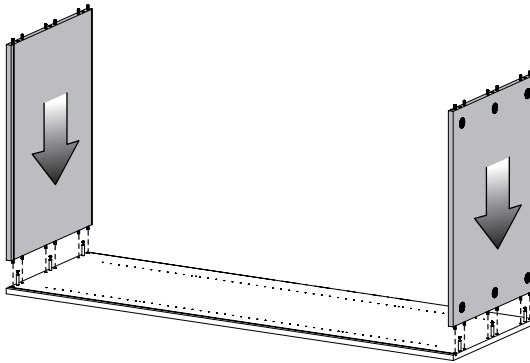

### 3.5 Optional: Bei Sitznische

#### 3.5.1 Sitzpolster von Zwischenboden abschrauben

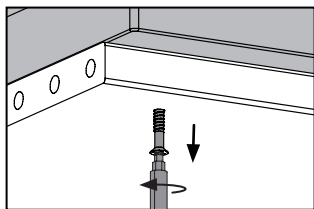
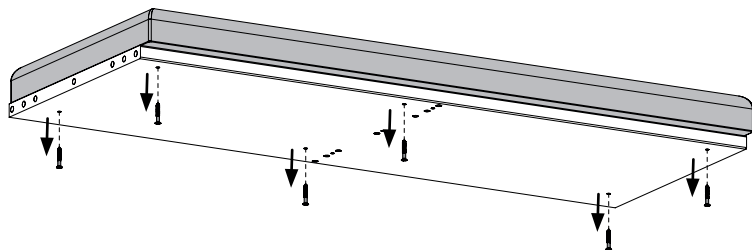

#### 3.5.2 Zwischenboden einbauen

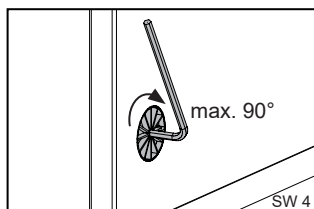
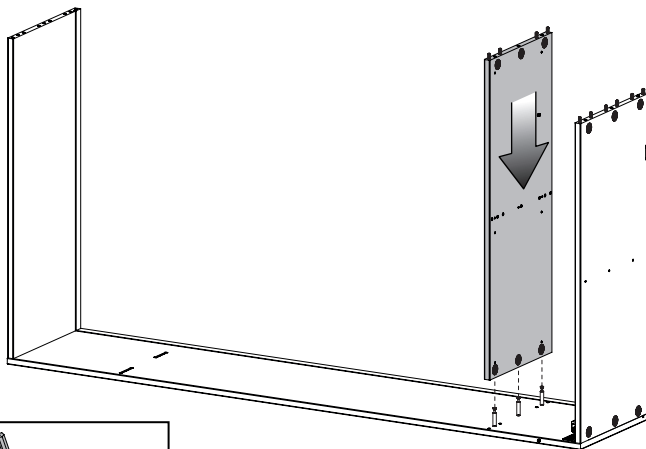

### 3.6 Rückwand einschieben

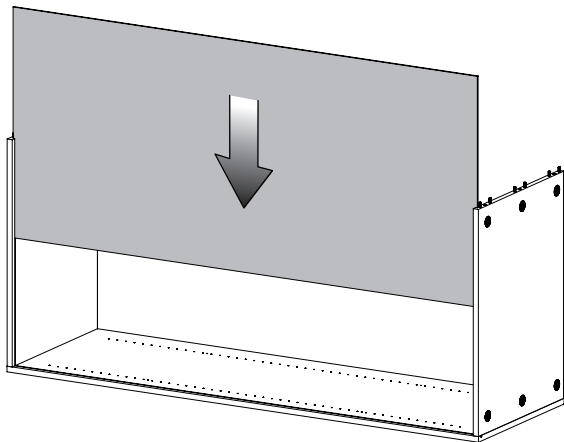

### 3.7 Außenseite befestigen

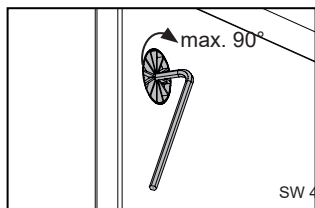
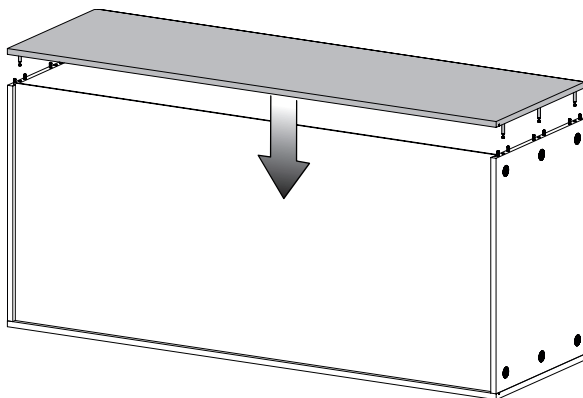

### 3.8.1 Optional: Bei Sitznische

Mittelseite mit unterem Boden und Zwischenboden verschrauben

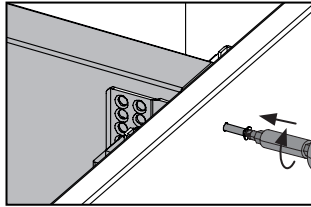
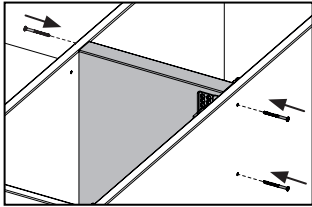
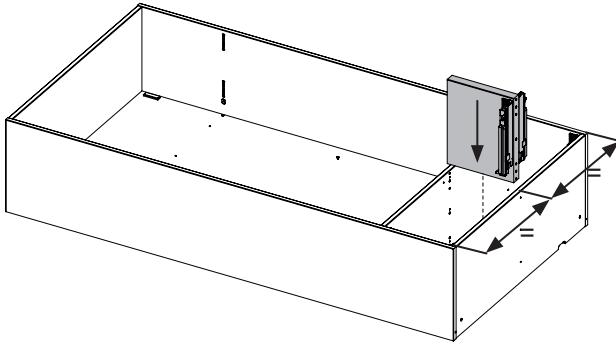

### 3.8.2 Sitzpolster wieder mit Zwischenboden verschrauben

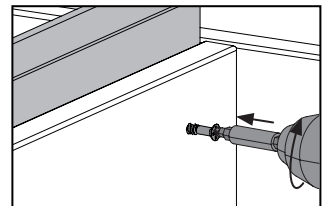
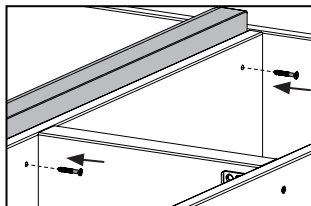
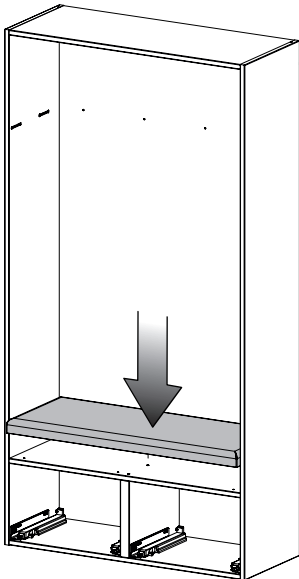

### 3.8.3 Rückwand verschrauben

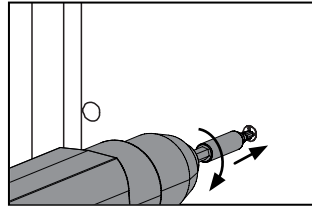
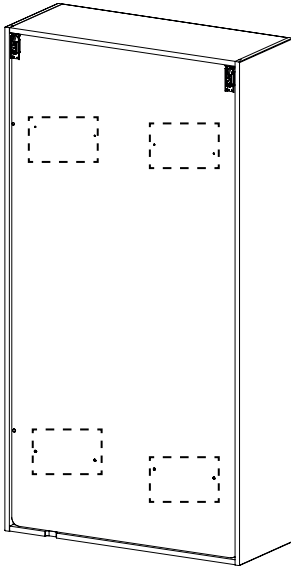

### 3.8.4 Zwischenboden einbauen

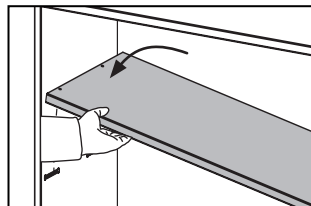
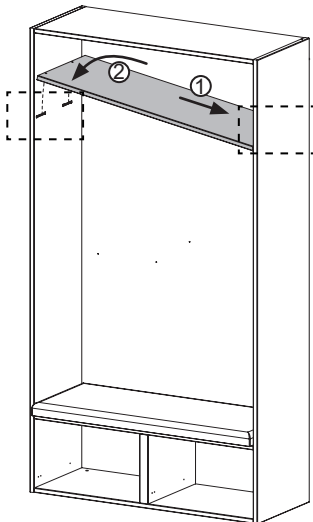

#### HINWEIS

- Den Boden immer rechts als erstes einhängen um das Kabel nicht einzuklemmen.

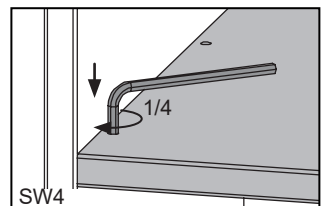

## 4. Korpusverbindungsmöglichkeiten

### 4.1 Korpusse verbinden

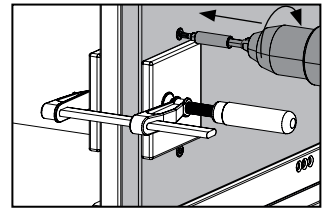
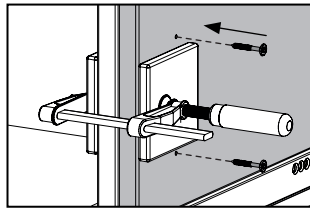
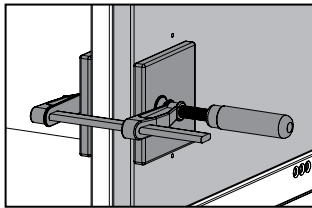
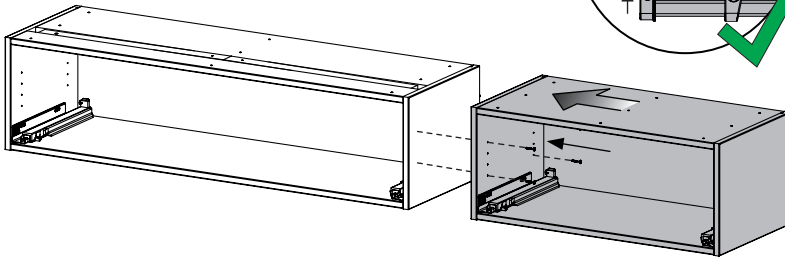
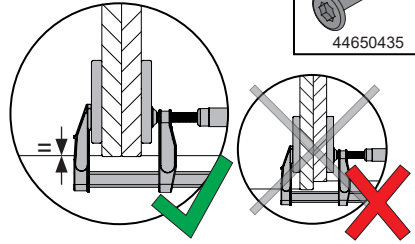

### 4.2 Optional: Bei Rollladenkorpus Aufsatzkorpus verschrauben

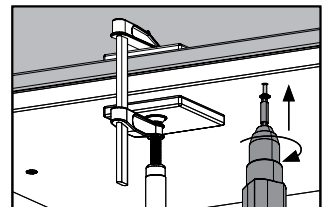
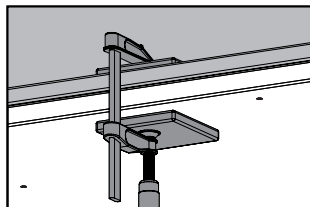
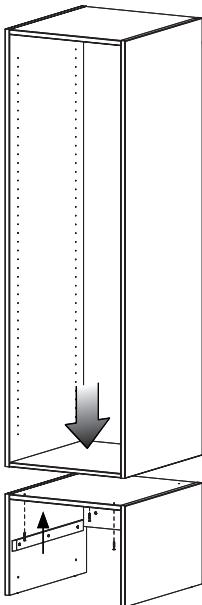
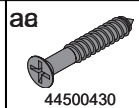

#### **! HINWEIS**

- Schrauben vorsichtig einschrauben.
- Seitlich und Vorne bündig ausrichten.

#### **! HINWEIS**

- Optional auch nur mit Deckplatte möglich. Montage siehe Punkt 9.
- Kippsicherung bei Aufsatzkorpus. Montage siehe Punkt 7.

## 5. Sockelvarianten

### 5.1 Rückspringender Sockelrahmen

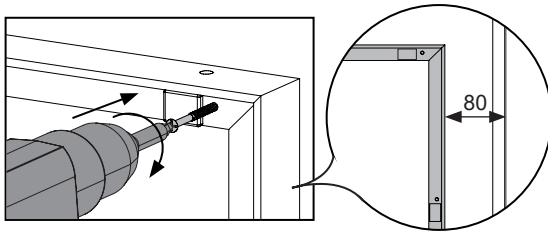
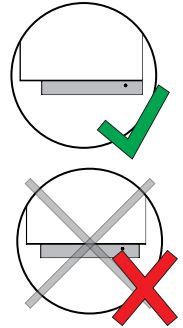
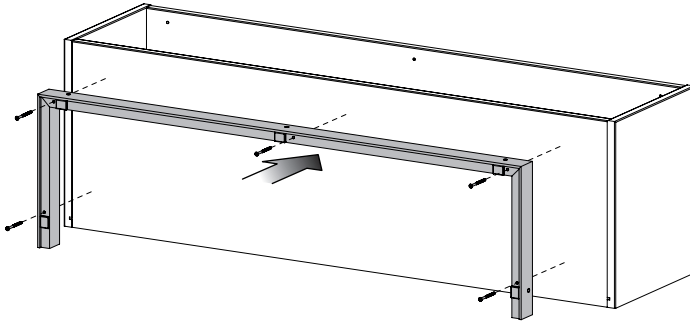
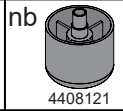
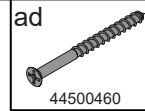

Optional: Bei Korpusstoß

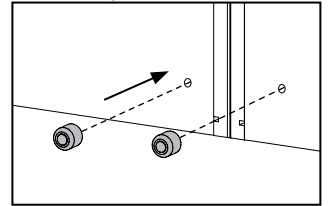

Alle Maße in Millimeter

### 5.2 Sockelmontage bei Platzproblem

#### 5.2.1 Korpus platzieren

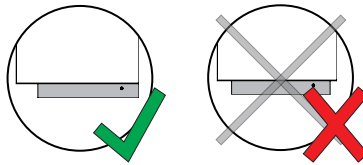
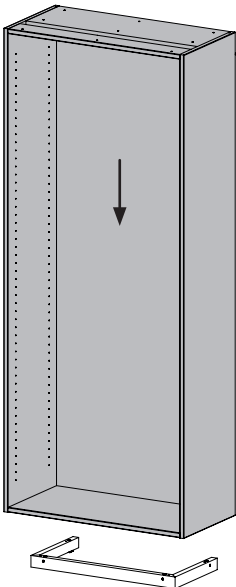
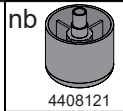

Optional: Bei Korpusstoß

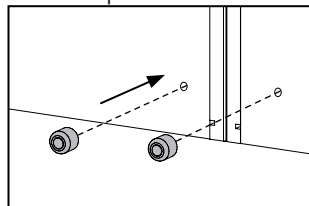

#### **HINWEIS**

- Schrauben sind später sichtbar. Sockelmontage von innen nur, wenn unbedingt notwendig!

### 5.2.2 Korpus mit Sockel verschrauben

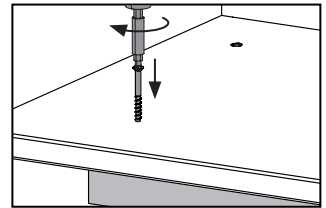
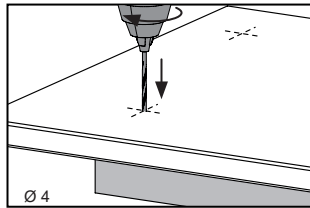
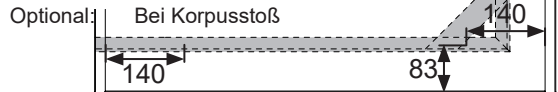
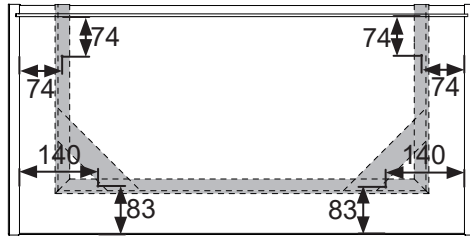
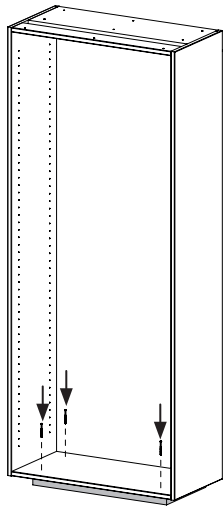
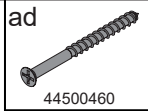

Alle Maße in Millimeter

### 5.3 Ausrichten

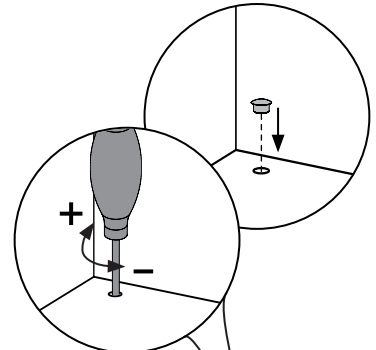
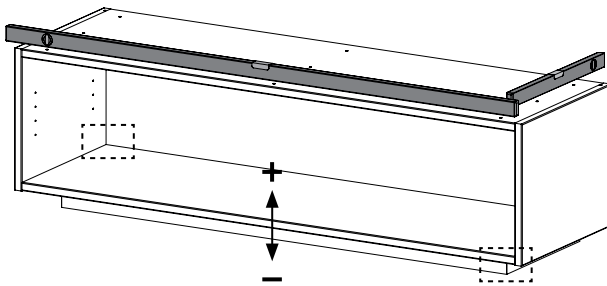
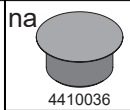

Optional:

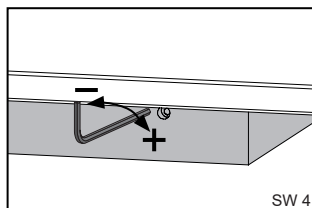
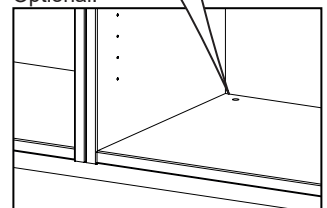



5.4 Optional: Bei Rollladenkorpus  
Korpus mittels Höhensteller ausrichten

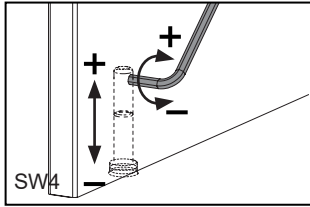
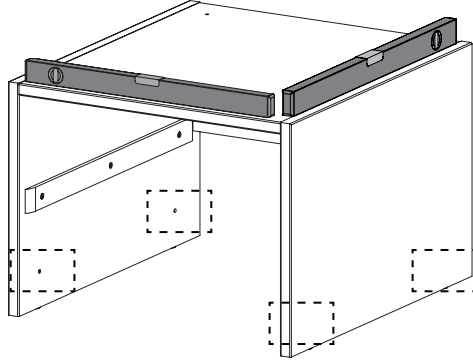

6. Platzierung

6.1 Plattformkorpus

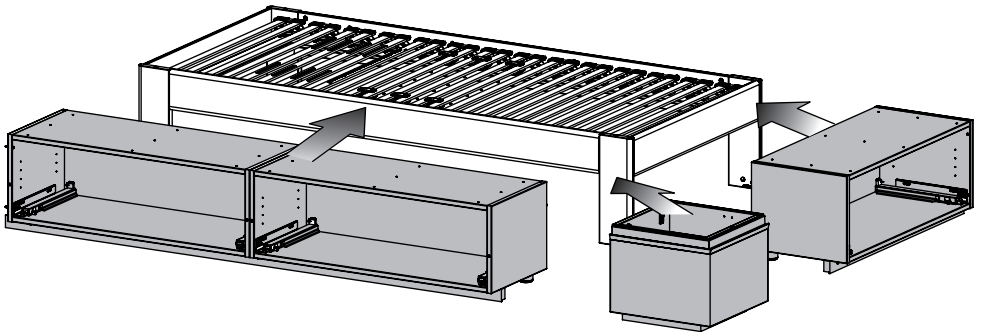

## 6.2 Eckkorpus verschrauben

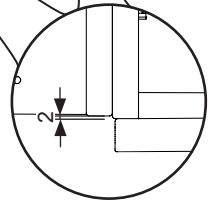
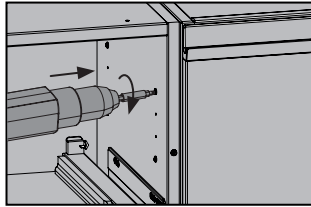
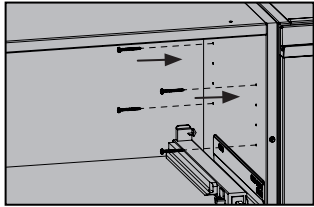
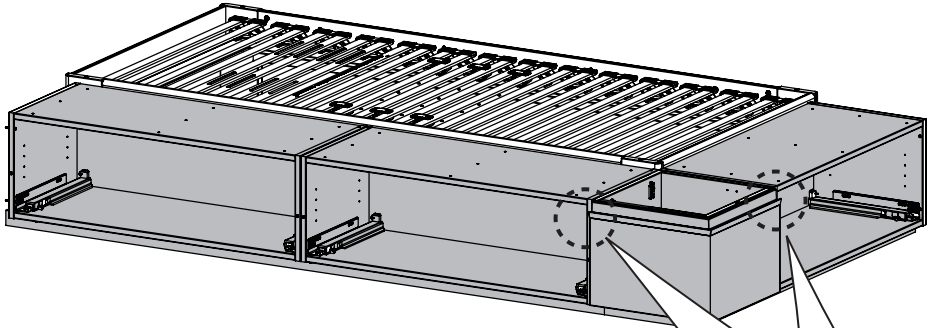
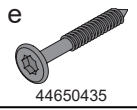

Alle Maße in Millimeter

## 6.3 Korpuse mit Bett verschrauben

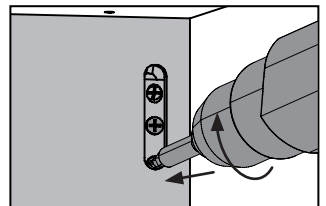
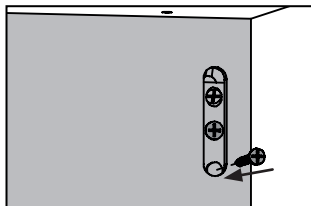
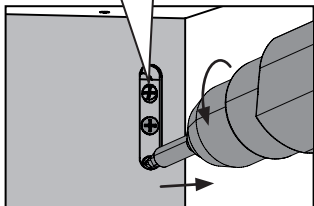
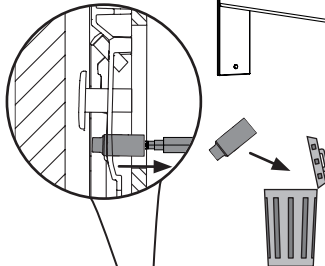
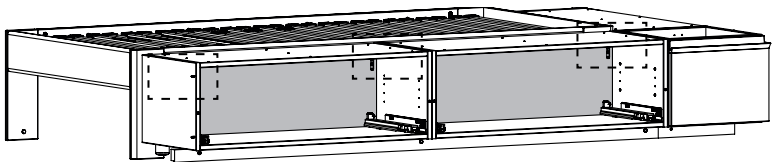

## 7. Kippsicherung

### 7.1.1 Montage Kippsicherung

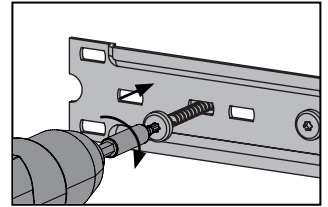
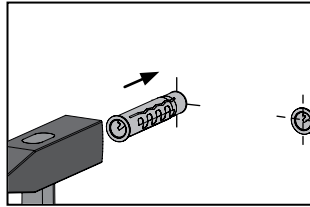
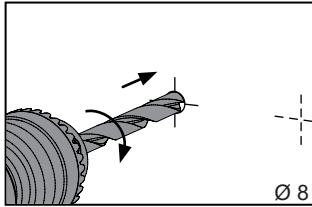
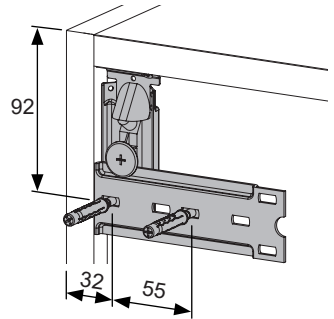
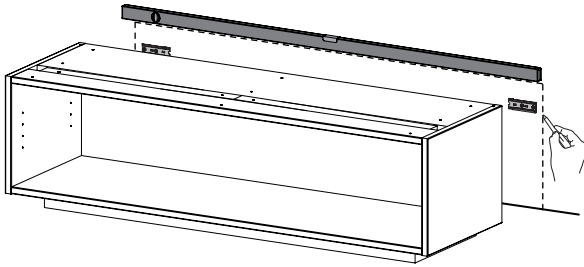
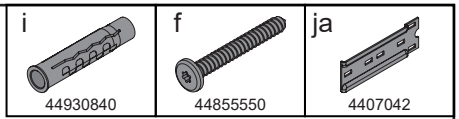

Alle Maße in Millimeter

### 7.1.2 Korpus einhängen

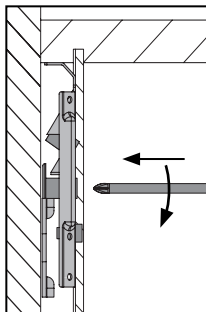
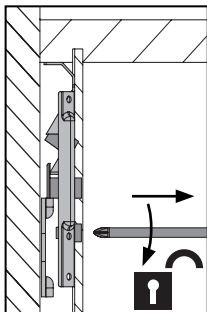
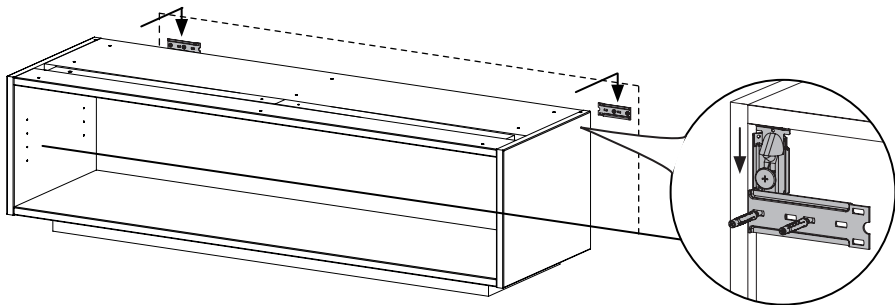

### 7.1.3 Beschlagseinstellungen

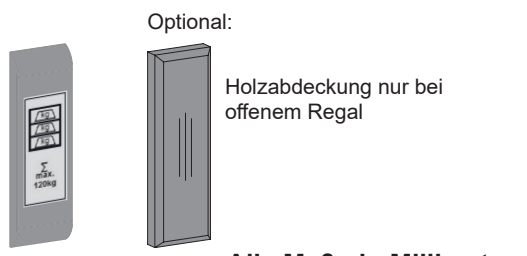
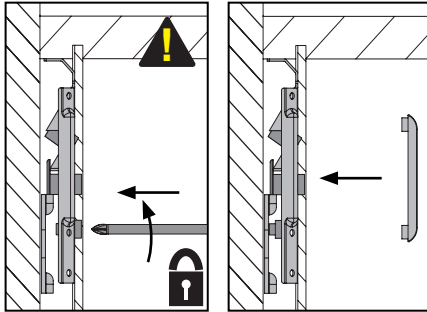
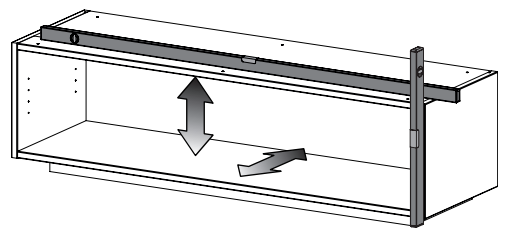
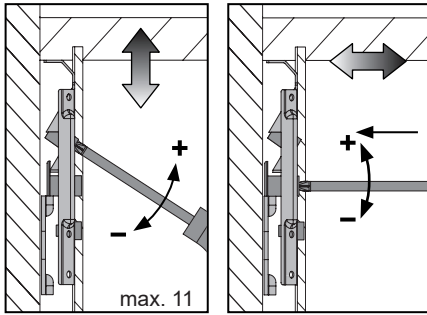
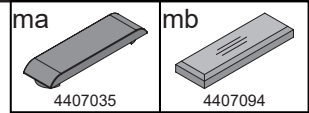

### 7.2 Optional: Bei Rolladenkorpus ohne Aufsatzschrank Variante mit Deckplatte

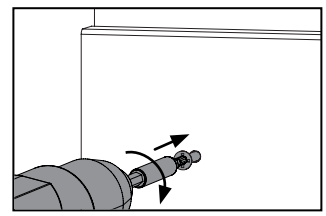
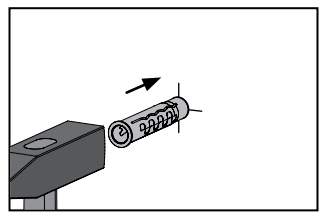
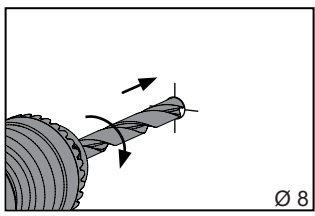
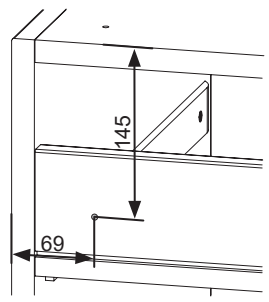
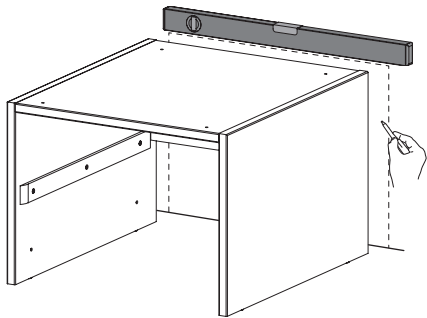
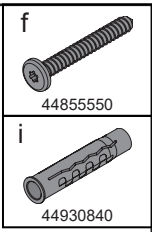

**Alle Maße in Millimeter**

### 7.3 Optional: Bei Bettruhe

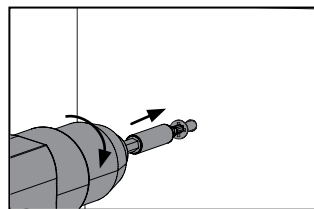
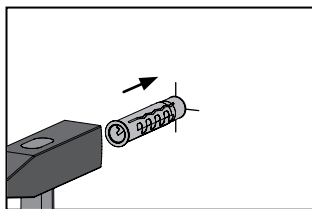
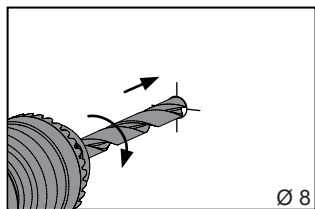
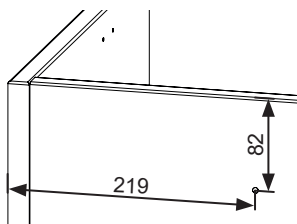
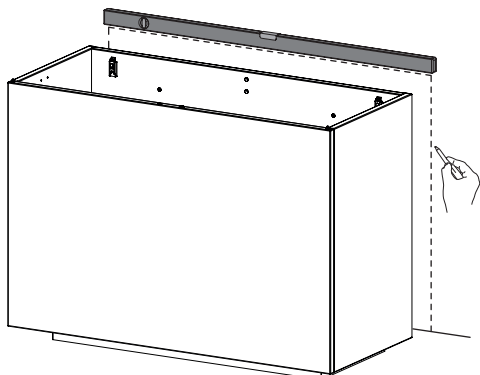
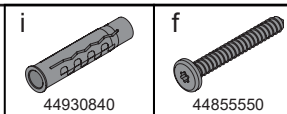

Alle Maße in Millimeter

### 8. Hängebeslag

#### 8.1 Montage Hängebeslag

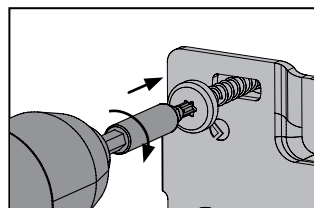
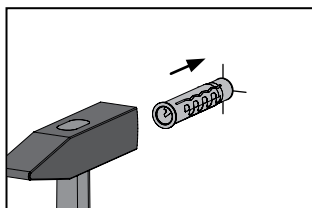
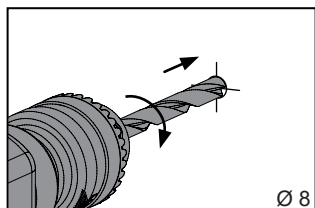
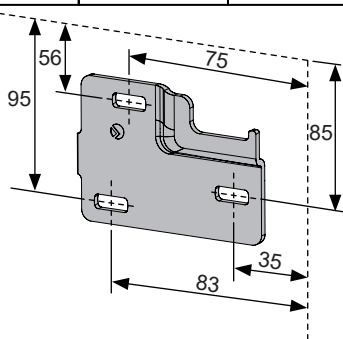
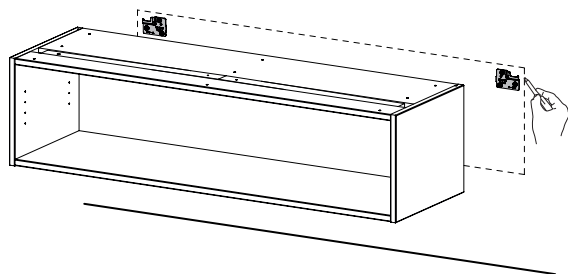
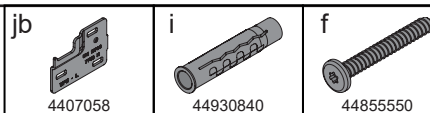

Alle Maße in Millimeter

## 8.2 Korpus einhängen und ausrichten

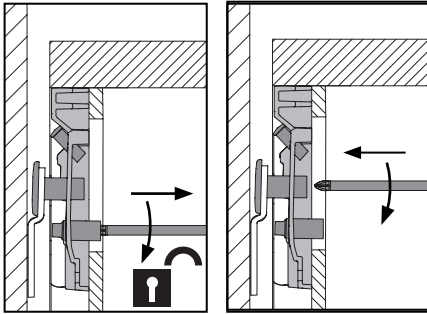
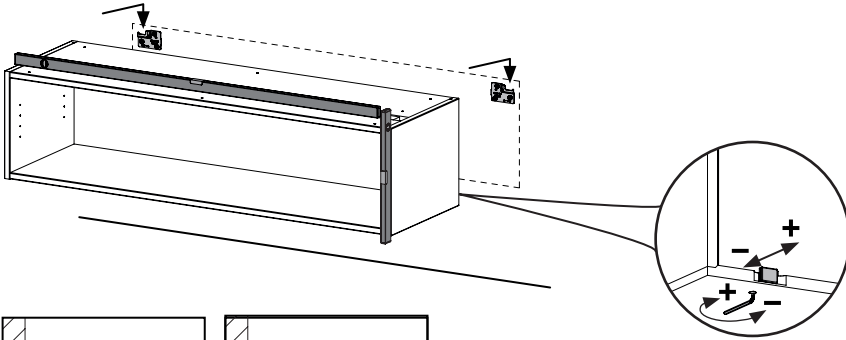

### **HINWEIS**

- Belastung max. 120kg.

## 8.3 Beschlagseinstellungen

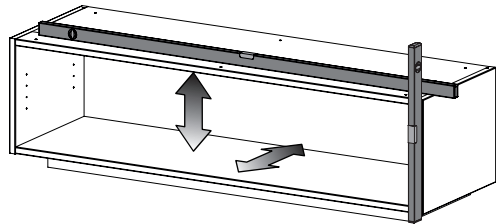
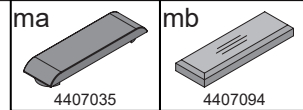
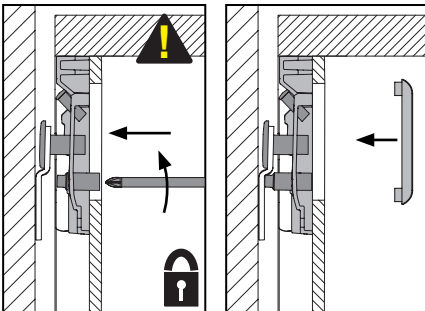
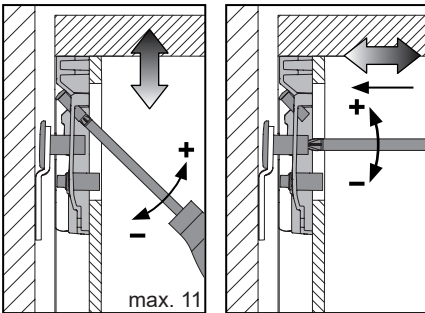

Optional:  
Holzabdeckung nur bei  
offenem Regal

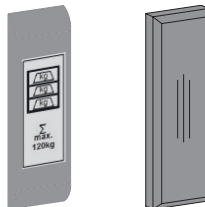

**Alle Maße in Millimeter**

## 9. Seitenblenden- und Deckplattenmontage

### 9.1 Seitenblende

ab

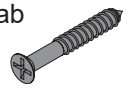

44500435

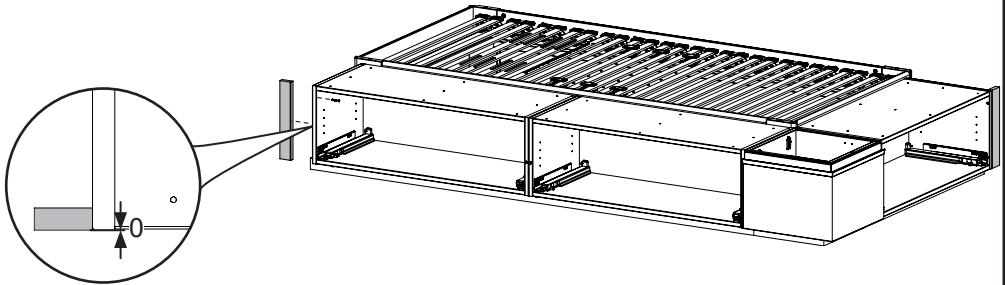

#### **⚠ HINWEIS**

- Blenden müssen zur Wand angepasst werden.

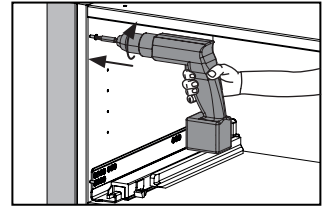
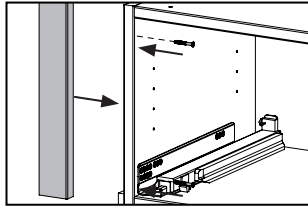

### 9.2 Deckplatten verbinden



4406061

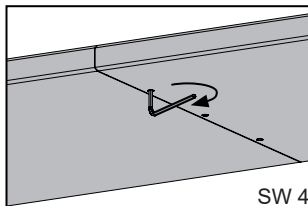
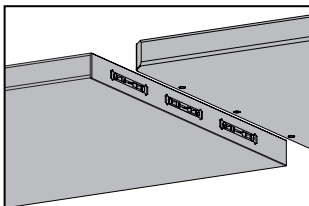
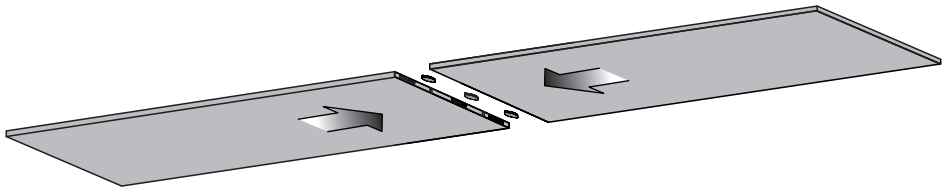

### 9.3 Deckplatte montieren

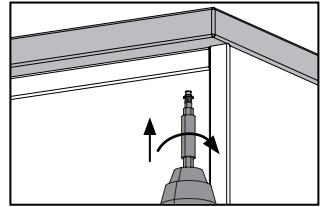
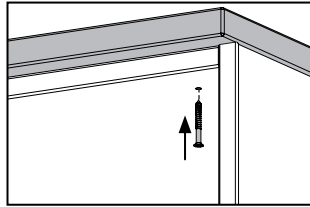
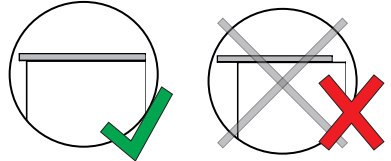
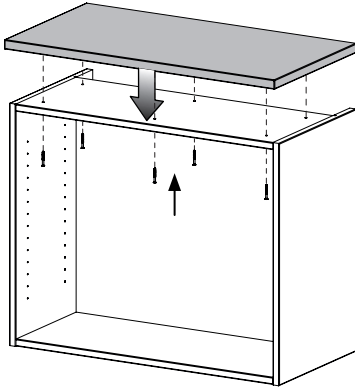
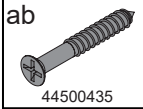

### 10. Rollen montieren

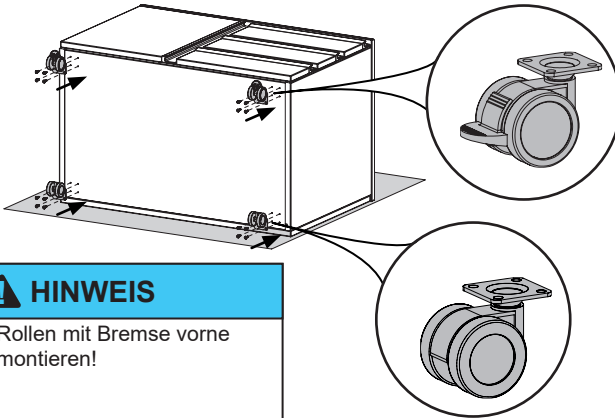

#### **HINWEIS**

- Rollen mit Bremse vorne montieren!

#### **HINWEIS**

- Unterlage verwenden!
- Die Unterlage muss sauber und frei von spitzen und scharfkantigen Gegenständen sein.

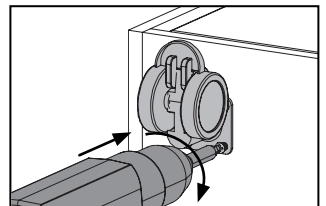
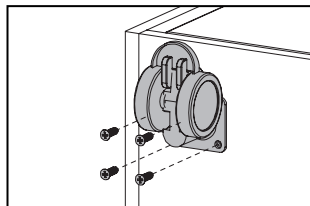
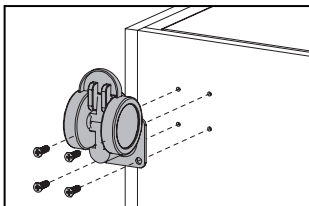



# 11. Frontkomponenten

## 11.1 Lade

Lade aushängen

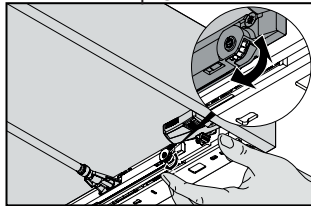
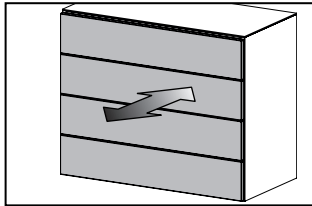
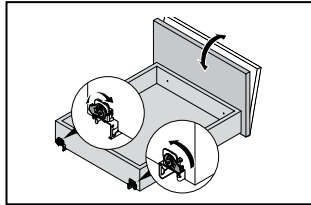
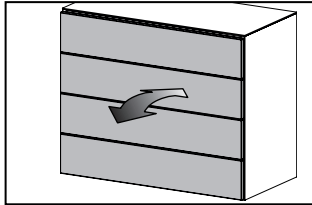
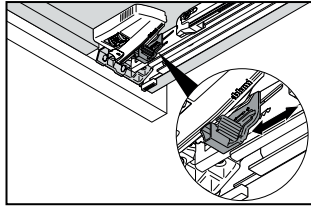
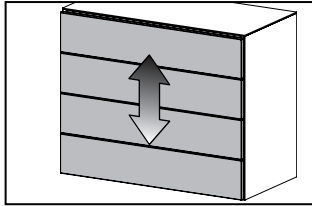
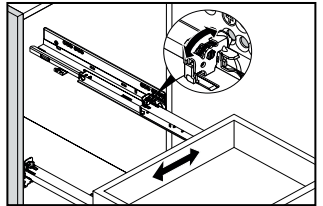
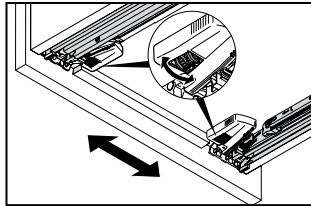
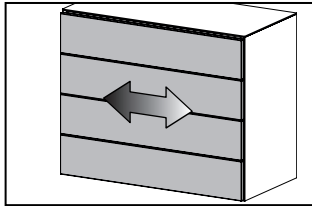
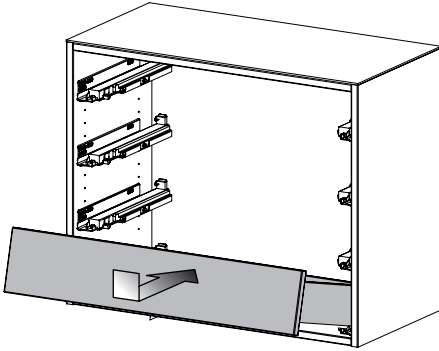
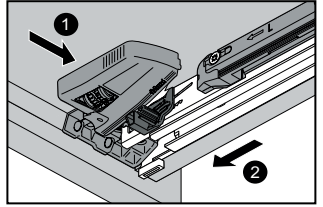
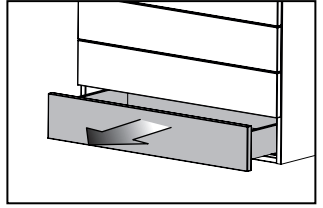

bei Variante Tip-On



## 11.2 Klappenposition einstellen

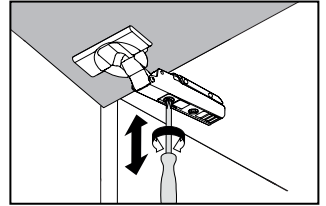
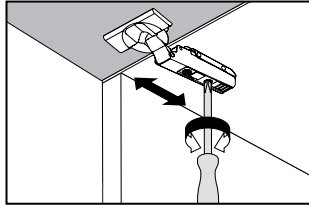
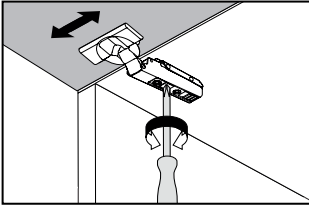
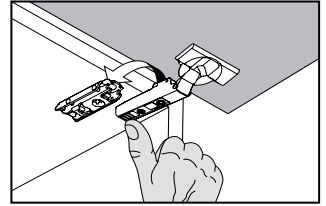
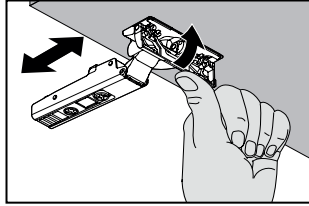
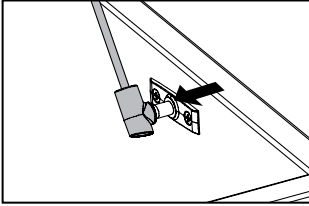
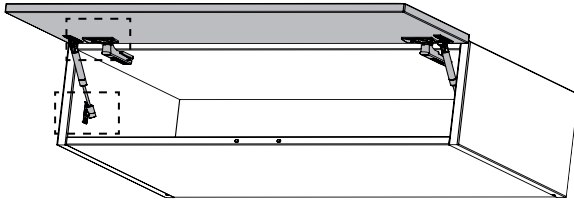

## 11.3 Drehtür

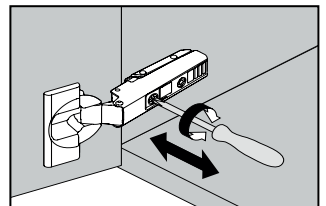
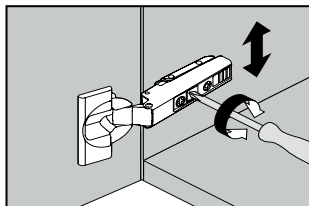
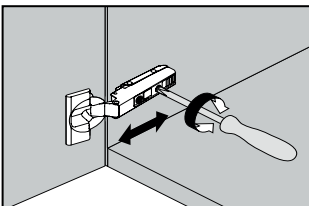
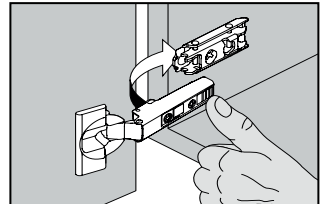
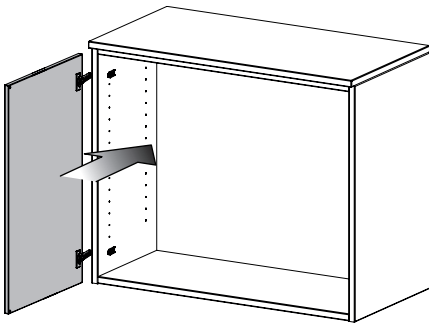

# 11.4.1 Rolllade

## Rollen montieren

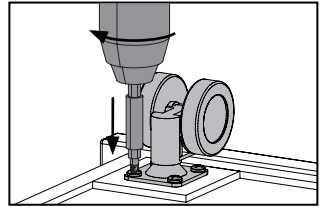
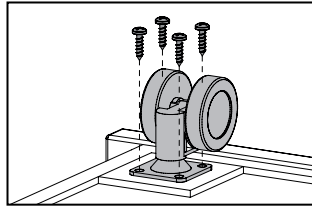
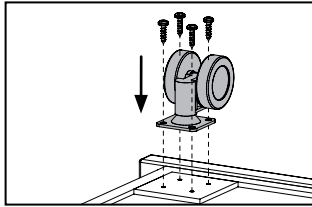
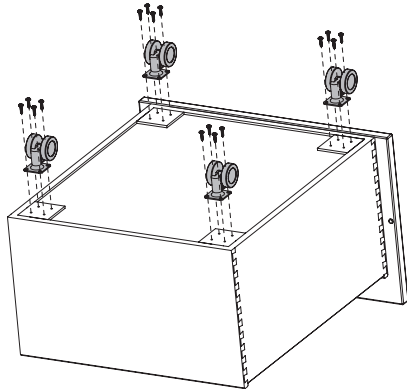
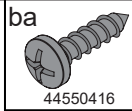

# 11.4.2 Optional: Bei großem Frontabstand

## Distanzplatte einlegen

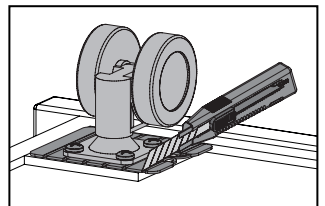
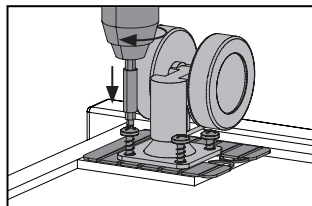
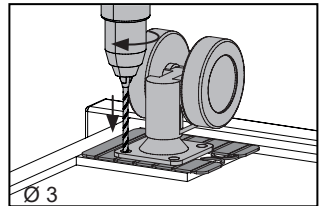
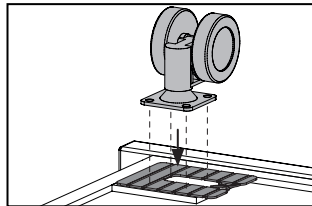
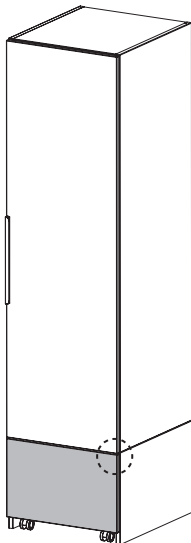
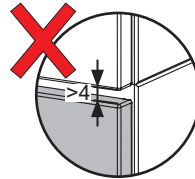
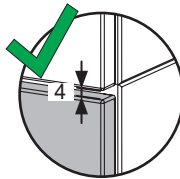
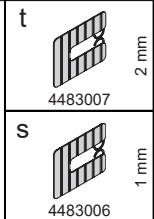

Alle Maße in Millimeter

### 11.4.3 Rolllade einstellen

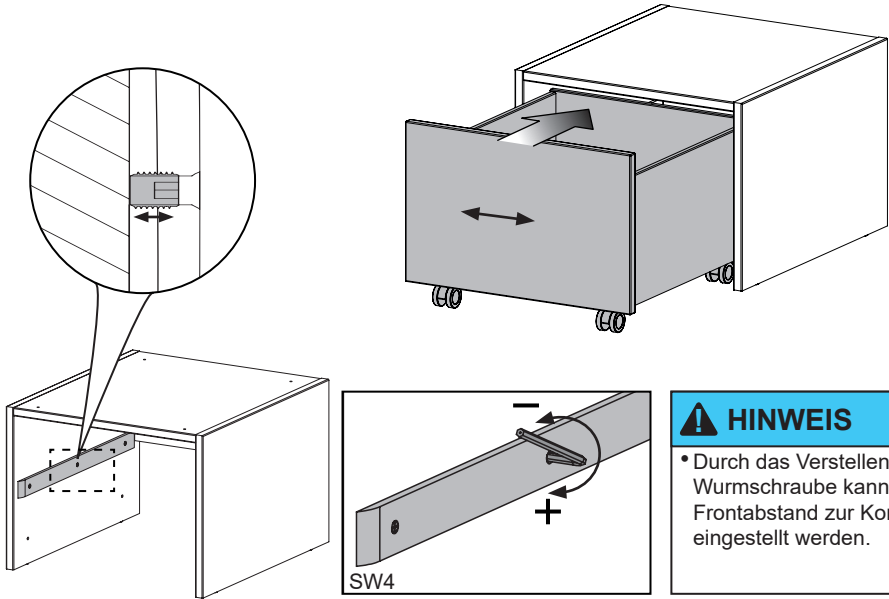

### 11.5 Wandpaneel einhängen

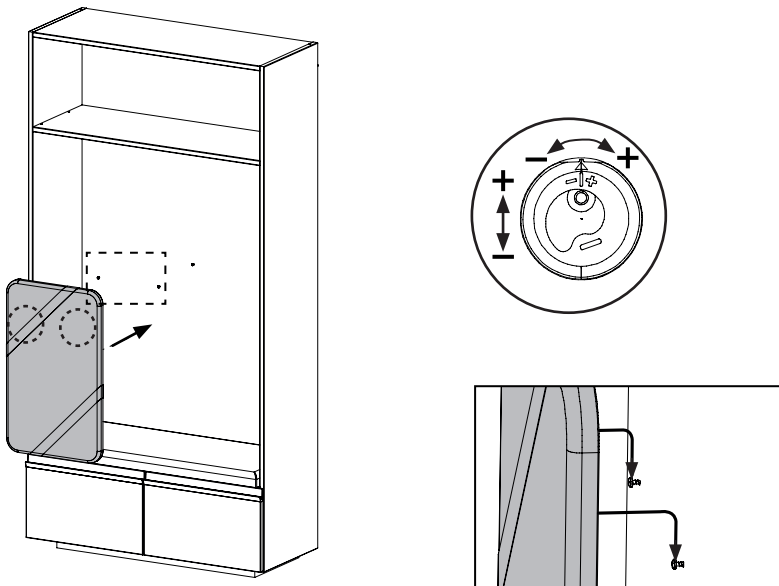

## 11.6 Licht ein- und ausschalten

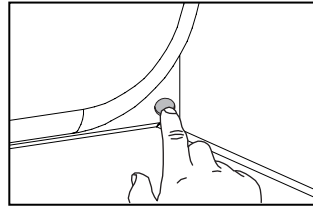
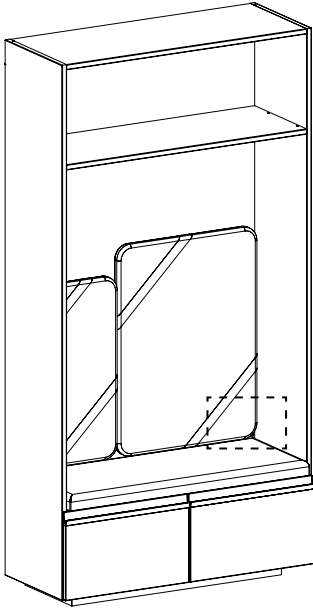

## 12. Inneneinteilungen

### 12.1 T-Einteilung

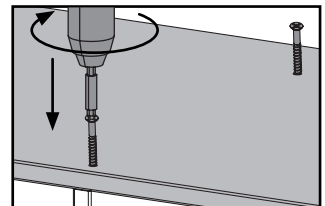
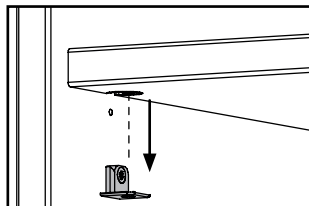
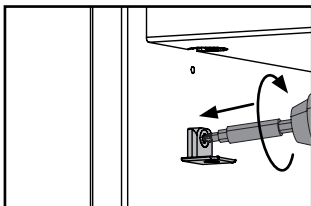
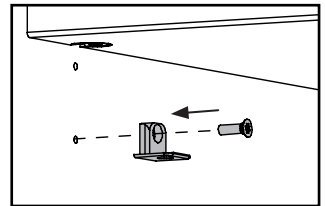
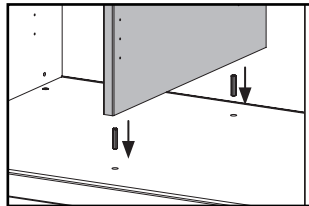
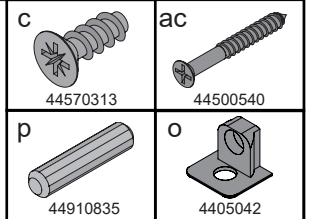
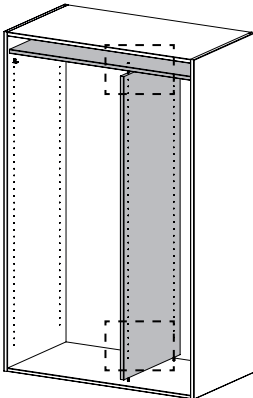

## 12.2 Kleiderstange

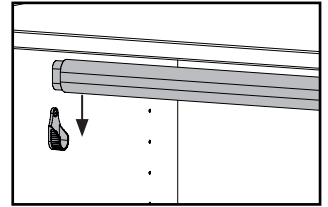
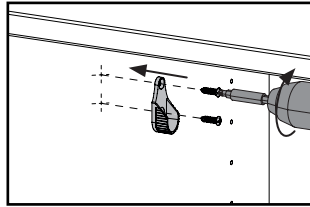
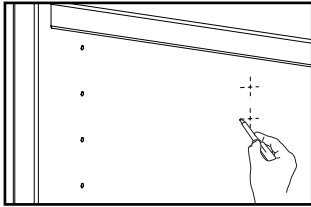
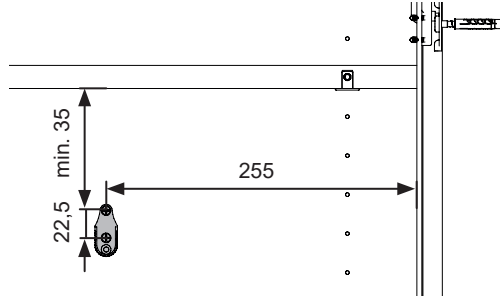
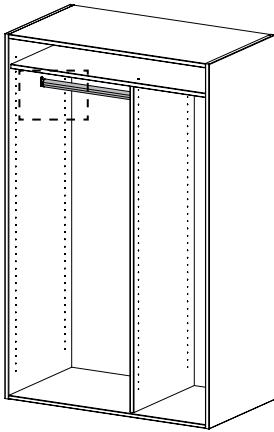
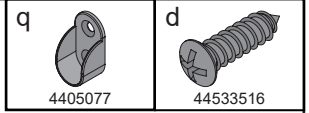

Alle Maße in Millimeter

## 12.3 Fach mit Kleiderstange

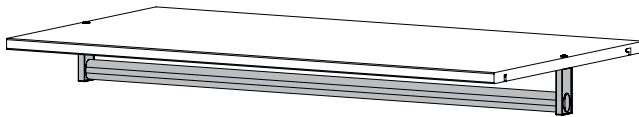
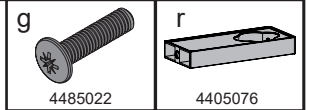

**Hinweis**

- Fach mit Bohrloch ist für die Montage der Kleiderstange vorgesehen.
- Ausklüngen für Fächerträger müssen auf der Unterseite sein.

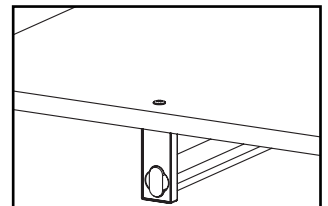
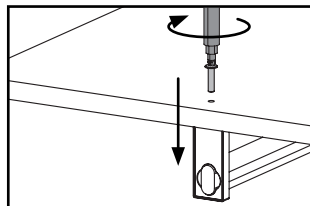
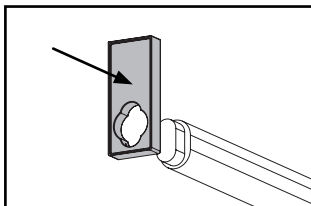

## 12.4 Sicherheitsfach

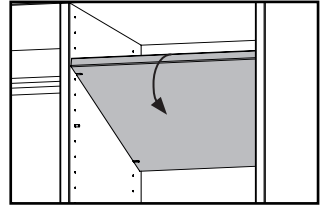
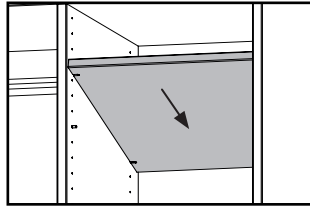
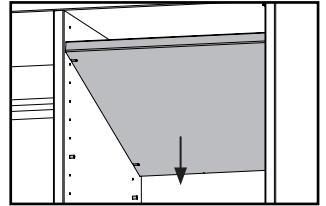
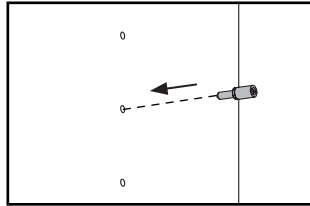
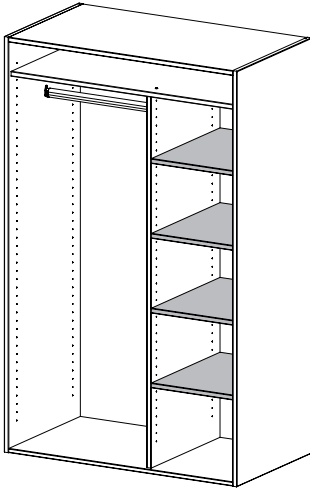
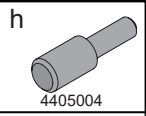

# TEAM 7

## **TEAM 7 Natürlich Wohnen GmbH**

Braunauer Str. 26  
4910 Ried im Innkreis, AUSTRIA

**Montagehotline: +43/7752-977321**

[www.team7-home.com](http://www.team7-home.com)

Änderungen, Irrtümer, Druck- und Satzfehler vorbehalten

### Urheberrecht

Das Werk einschließlich aller Teile ist urheberrechtlich geschützt. Jede Verwertung außerhalb der engen Grenzen des Urheberrechtsgesetzes ist ohne Zustimmung der Firma TEAM 7 GmbH unzulässig und strafbar. Das gilt insbesondere für Vervielfältigung, Mikroverfilmung und die Einspeicherung und Verarbeitung in elektrische Systeme.



# TEAM 7

Dokument für  
die qualifizierte  
Fachkraft!



## Instructions de montage

# *Kids*

## Corps modulaire

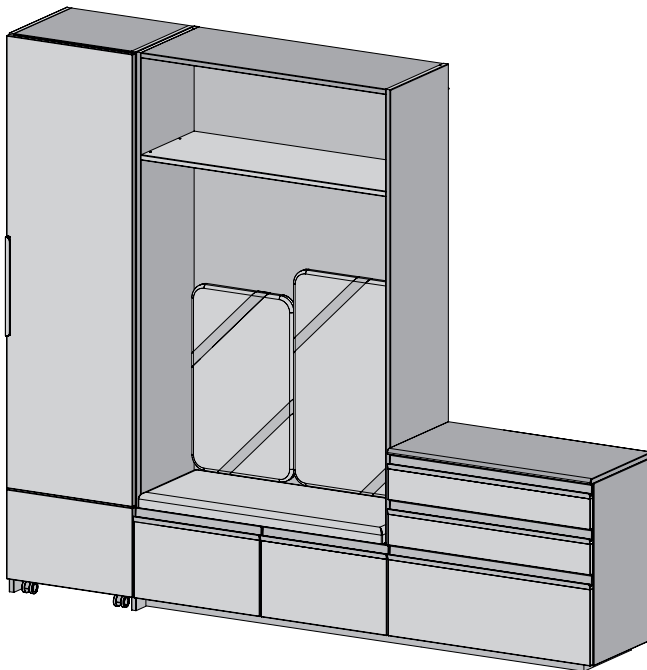

122022  
TD284010A

# FR

Nach der Montage  
zur Aufbewahrung für  
unsere Kunden!

## ! CLIMAT INTERIEUR

- Climat intérieur idéal pour les personnes, les plantes et les meubles en bois naturel :

**une humidité relative comprise entre 40 et 60 % et  
Température ambiante : de 18 à 23 °C.**

- Le dépassement supérieur et/ou inférieur prolongé de ces valeurs entraîne une rétraction ou un gonflement de ce matériau. Risque de déformation, fissure, joint décollé et surface rugueuse.

## ! ENTRETIEN

- Les consignes d'entretien sont disponibles sur le site Internet TEAM 7 (entretien du bois naturel, du cuir, de l'étoffe, du Stricktex, de la pierre, du verre, métal, céramique du feutre et des plans de travail)

- Vous trouverez d'importantes caractéristiques des meubles en bois naturel TEAM 7 également dans le certificat de service et de qualité à l'adresse suivante :

<https://www.team7-home.com/at/de/service/service-und-guetepass/>



## ! DOCUMENTATION

- Veuillez conserver soigneusement tous les documents d'achat de votre meuble, même au-delà de la garantie légale de deux ans.
- S'il vous faut des pièces de rechange ou des accessoires, tous les renseignements concernant le produit que vous aurez acheté figurent sur ces documents.
- Si votre meuble a été endommagé durant le transport, joindre impérativement des photos de la partie endommagée dans l'emballage d'origine.

## ! ATTENTION

- Les accessoires de fixation murale, compris dans l'étendue de la livraison, sont conçus pour les murs en béton, en brique pleine et creuse\*. Pour tous les autres types de mur, utiliser impérativement des chevilles spéciales.  
\* Ne pas utiliser de percussion pour les briques perforées !
- Un spécialiste est tenu de vérifier et de contrôler l'aptitude des accessoires de fixation à supporter les charges ! Le cas échéant, utiliser d'autres accessoires de fixation adaptés au mur !
- En cas de non-respect de cette consigne de sécurité, TEAM 7 se dégage de toute responsabilité !

## ! ATTENTION

- Tous les travaux électriques doivent être effectués par un spécialiste approprié!
- Ne jamais ouvrir le bloc d'alimentation. Il y a danger de mort !
- Le nombre total de watts des spots ne doit pas être supérieur aux watts du transfo ou de la télécommande.
- Si un passe-câbles n'est pas prévu, en couper un avec une scie sauteuse.

## Sommaire

<b>1.</b>	<b>Contrôle pièce / planification</b>	<b>5</b>
<b>2.</b>	<b>Aperçu des différents modèles</b>	<b>6-7</b>
<b>3.</b>	<b>Assemblage corps</b>	<b>8-13</b>
<b>4.</b>	<b>Assemblages de corps possibles</b>	<b>14</b>
4.1	Raccorder les corps	14
4.2	Corps à poser	14
<b>5.</b>	<b>Montage du socle</b>	<b>15-17</b>
5.1	Socle en retrait	15
5.2	Montage du socle en cas d'espace restreint	15-16
5.3	Ajuster	16
5.4	Corps tiroir sur roulettes : vérin	17
<b>6.</b>	<b>Mise en place</b>	<b>17-18</b>
<b>7.</b>	<b>sécurité anti-bascule</b>	<b>19-21</b>
7.1	Montage sécurité anti-bascule	19-20
7.2	Sécurité anti-basculement corps tiroir sur roulettes	20
7.3	Sécurité anti-basculement coffre	21
<b>8.</b>	<b>Montage ferrure de suspension</b>	<b>21-22</b>
7.1	Montage ferrure de suspension	21
7.2	Accrocher et aligner corps	22
7.3	Réglages de la ferrure	22
<b>9.</b>	<b>Montage des caches latéraux et du panneau de finition</b>	<b>23-24</b>
9.1	Cache latéral	23
9.2	Raccorder les panneaux de finition	23
9.3	Monter le panneau de finition	24
<b>10.</b>	<b>Monter les roulettes</b>	<b>24</b>
<b>11.</b>	<b>Composants façade</b>	<b>25-28</b>
11.1	Tiroir	25
11.2	Abattant	26
11.3	Porte pivotante	26
11.4	Roulette	27-28
11.5	Panneau mural	28
11.6	Allumer et éteindre la lumière	29
<b>12.</b>	<b>Compartimentages intérieurs</b>	<b>29-31</b>
12.1	Compartimentage en T	29
12.2	Tringle à habits	30
12.3	étagère avec tringle à habits	30
12.4	Compartiment de sécurité	31

# Outils

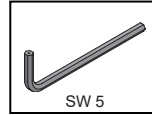
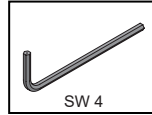
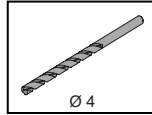
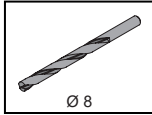
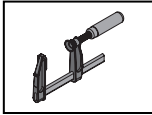
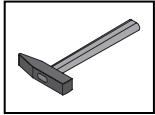
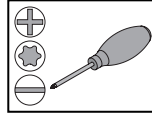
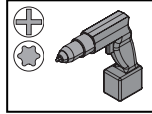
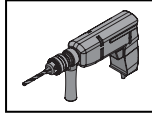
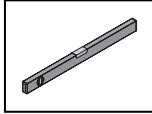
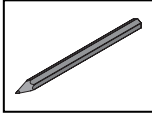

# Ferrures

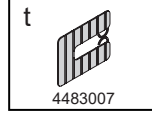
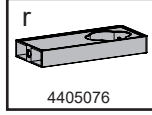
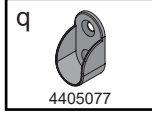
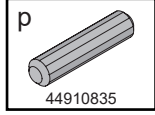
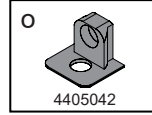
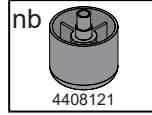
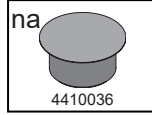
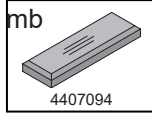
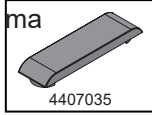
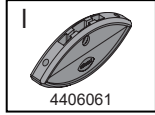
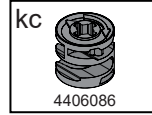
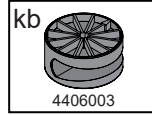
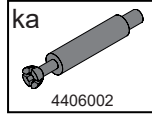
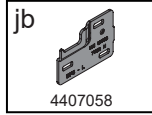
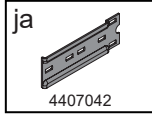
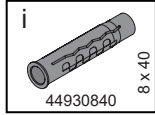
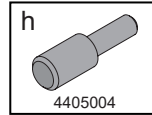
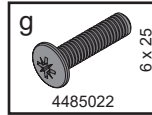
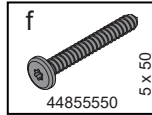
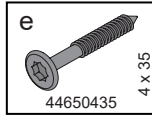
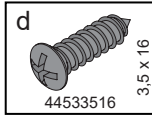
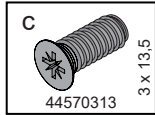
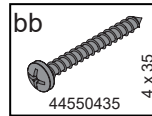
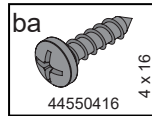
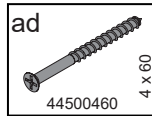
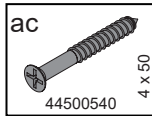
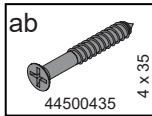
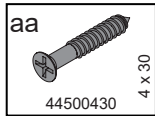

# 1. Contrôle pièce / planification

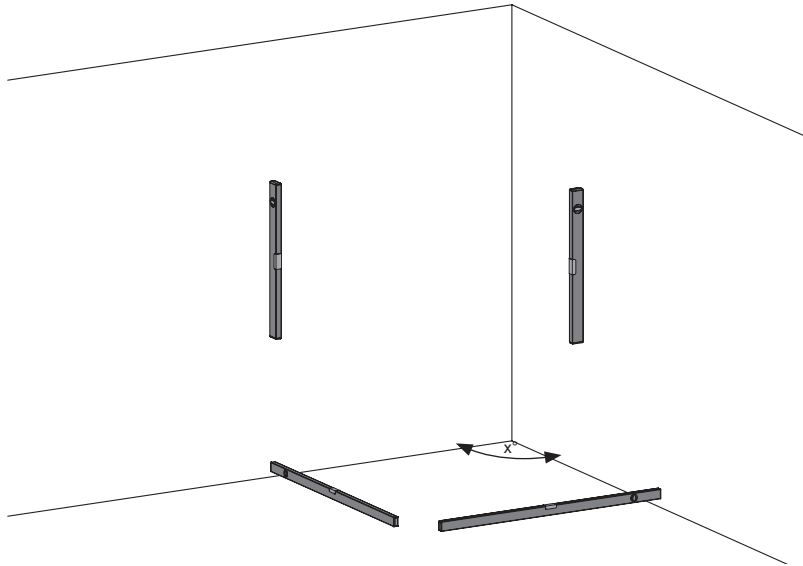

Notices

.....

.....

.....

.....

.....

.....

## 2. Aperçu des différents modèles

### Corps de base

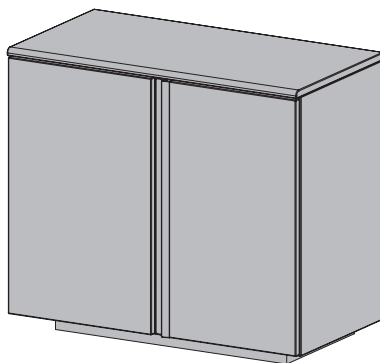
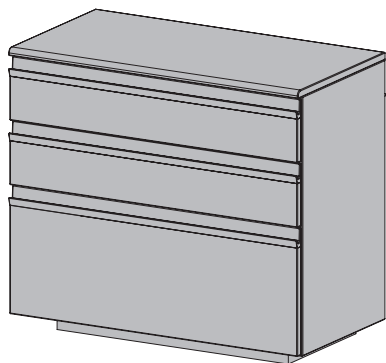

### Corps plateforme

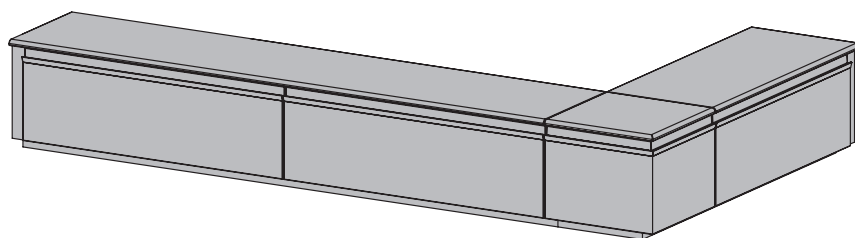

### Coffre

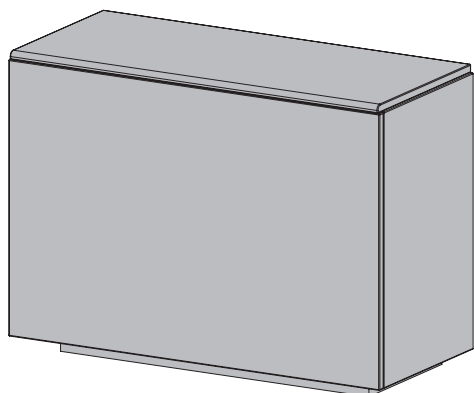

## Niche

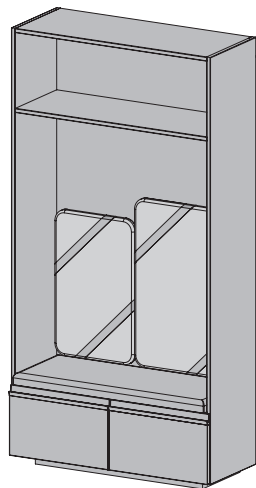

## Corps tiroir sur roulettes

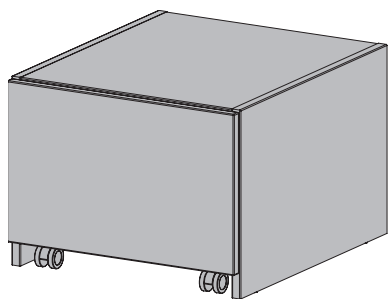

## Caisson à roulettes

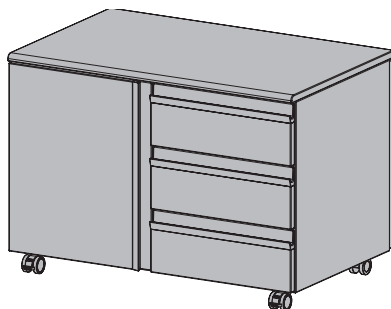
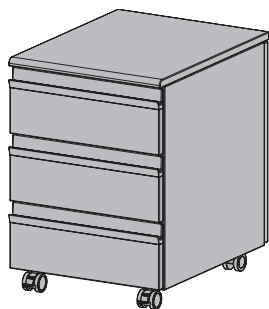

### 3. En option : Assemblage corps

#### 3.1 Corps en pièces détachées

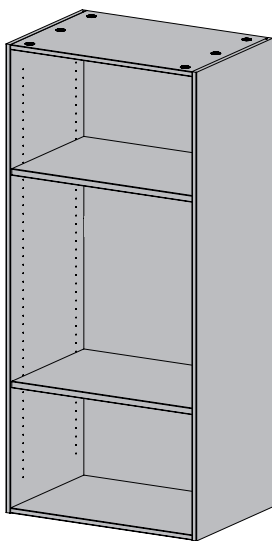

#### 3.2 Visser boulon

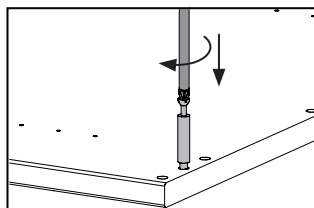
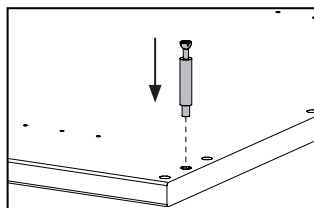
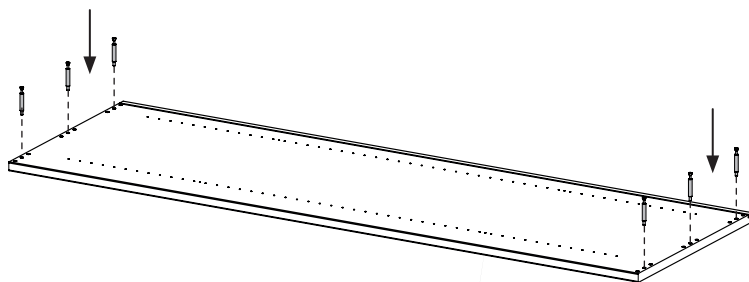
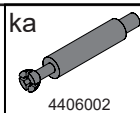



### 3.3 Enfonceur boîtier

kb



4406003

kc



4406086

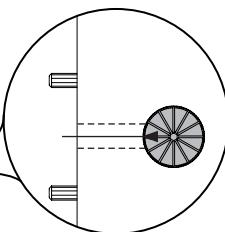
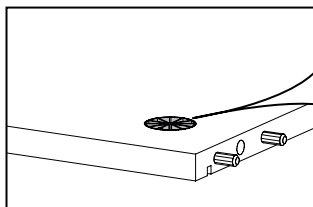
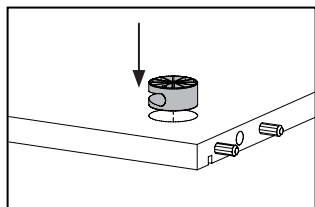
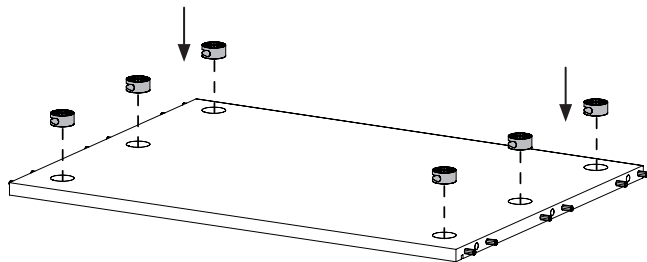

### 3.4 Fixer les fond et panneau supérieur

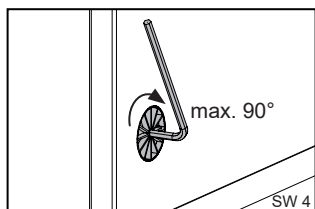
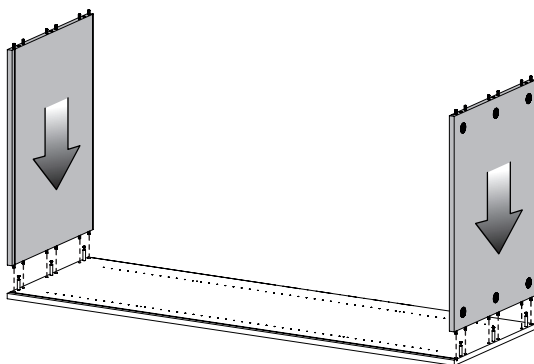

### 3.5 En option : Pour les niches

#### 3.5.1 Dévisser l'assise capitonnée de la tablette intermédiaire

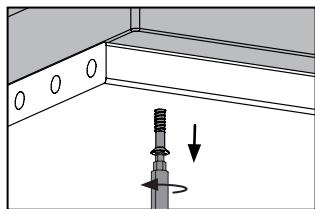
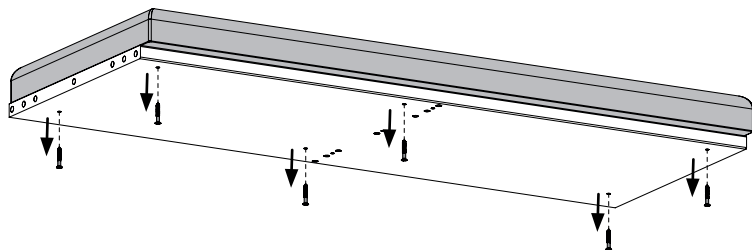

#### 3.5.2 Installer la tablette intermédiaire

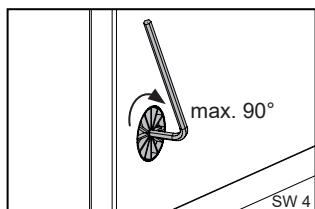
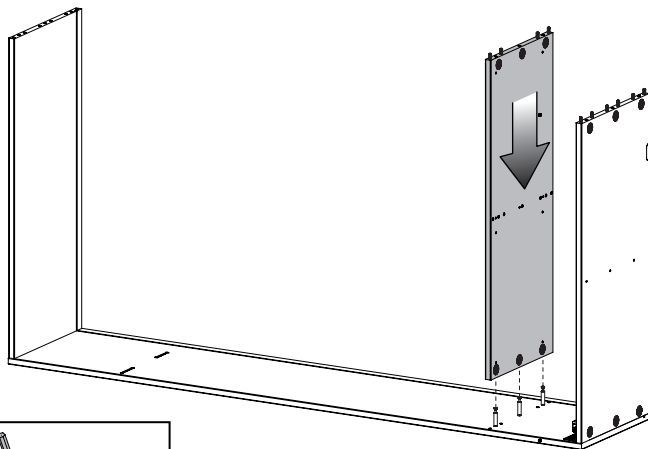

### 3.6 Pousser paroi arrière

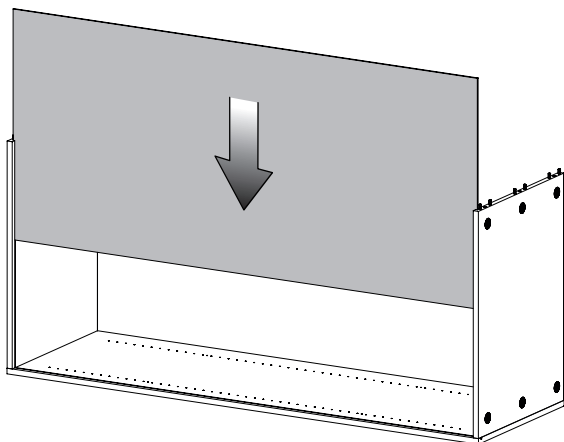

### 3.7 Fixer paroi extérieure

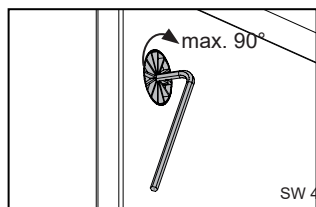
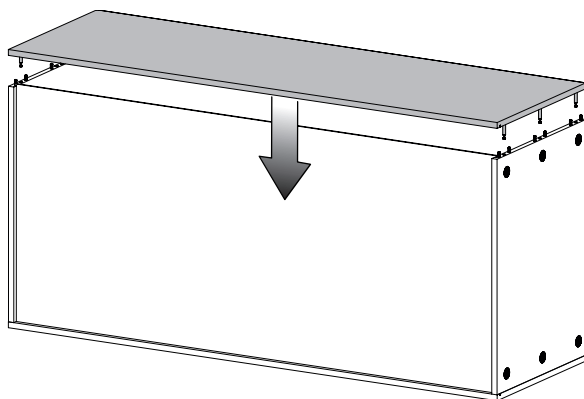

### 3.8.1 En option : Pour les niches

Visser la paroi médiane au fond inférieur et à la tablette intermédiaire

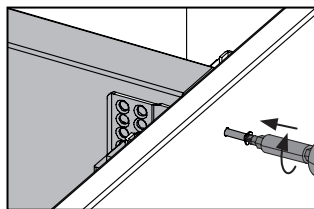
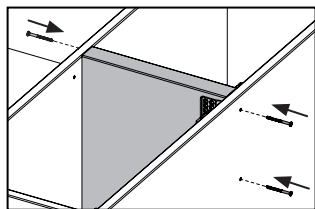
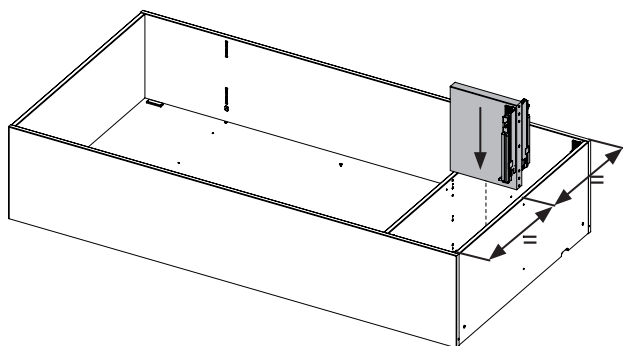

### 3.8.2 Revisser l'assise capitonnée à la tablette intermédiaire

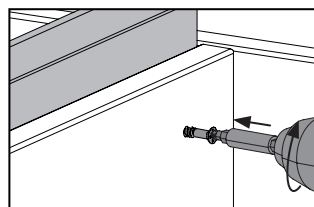
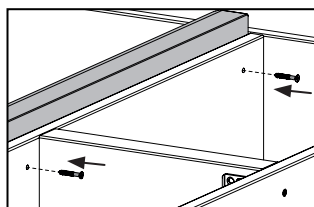
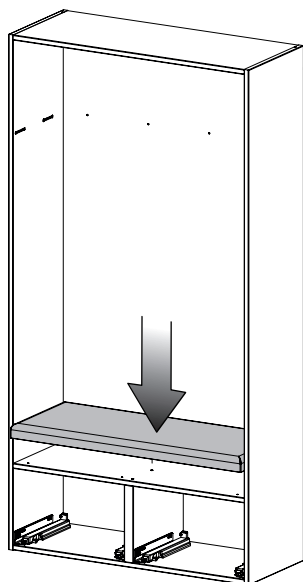

### 3.8.3 Visser la paroi arrière

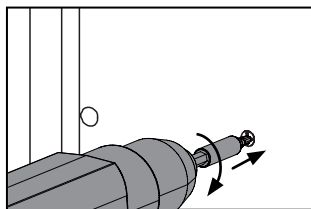
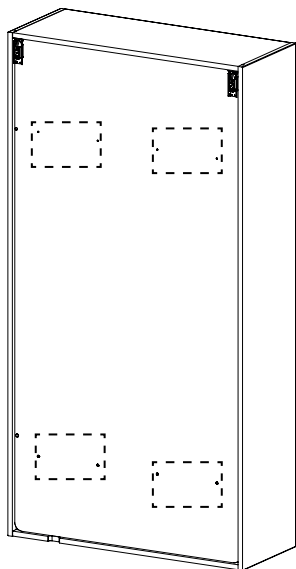

### 3.8.4 Installer la tablette intermédiaire

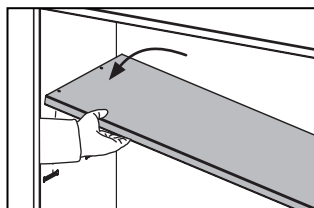
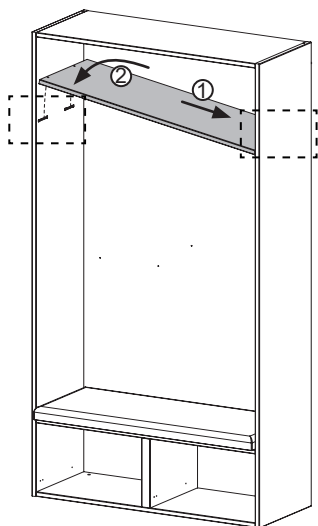

#### HINWEIS

- Accrocher toujours le fond en premier à droite pour ne pas coincer le câble.

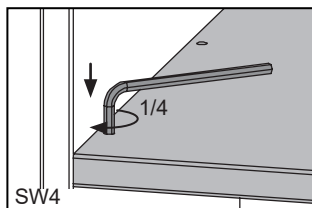

## 4. Assemblages de corps possibles

### 4.1 Raccorder les corps

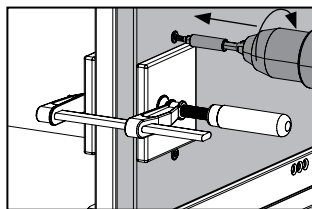
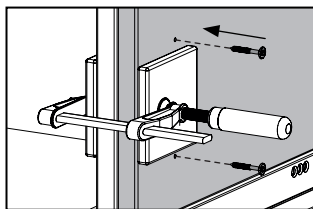
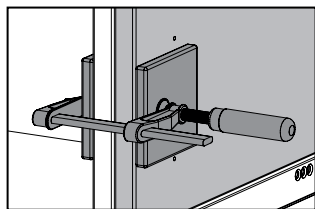
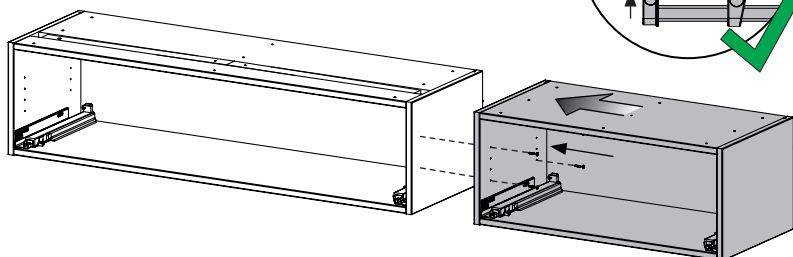

### 4.2 En option : Pour corps tiroir sur roulettes

Visser le corps à poser

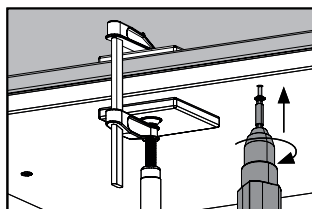
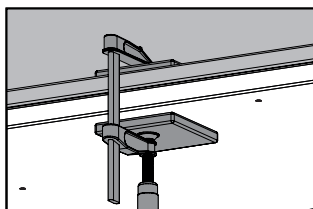
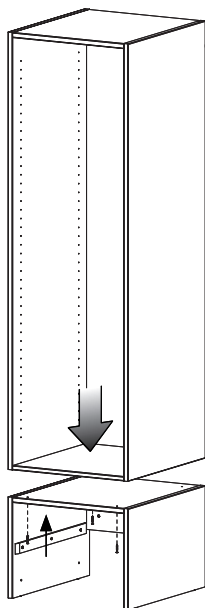

#### **! HINWEIS**

- Visser les vis avec la plus grande prudence.
- Aligner sur le côté et à l'avant à fleur.

#### **! HINWEIS**

- En option, aussi uniquement avec panneau de finition. Montage, voir point 9.
- Sécurité anti-basculement pour corps à poser. Montage, voir point 7.

## 5. Variantes de socle

### 5.1 Cadre de socle en retrait

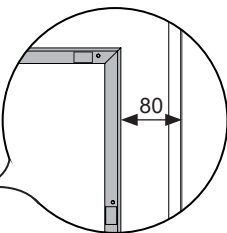
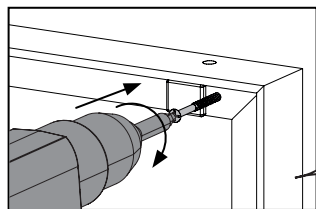
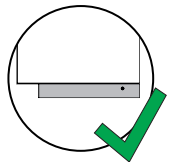
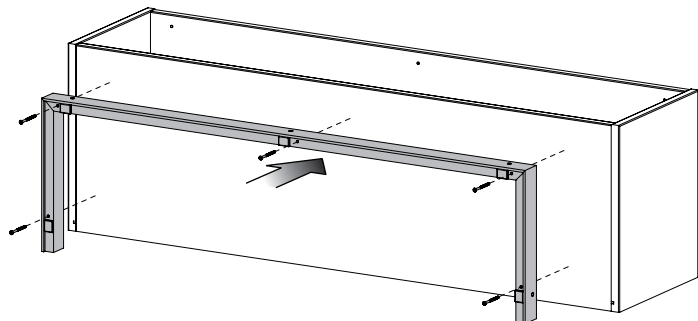
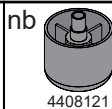
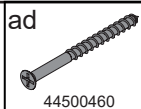

En option : En cas de joint de corps

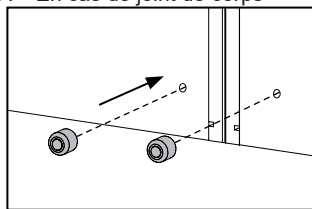

Alle Maße in Millimeter

### 5.2 Montage du socle en cas de problème de place

#### 5.2.1 Mettre en place le corps

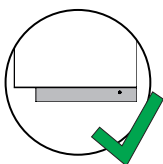
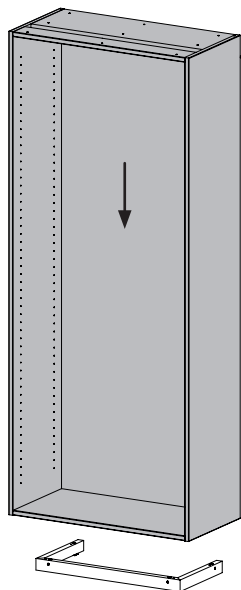
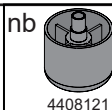

En option : En cas de joint de corps

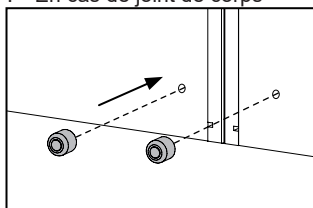

#### **HINWEIS**

- Les vis seront visibles. Montage du socle de l'intérieur, uniquement en cas d'absolue nécessité !

### 5.2.2 Visser le corps au socle

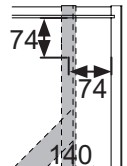
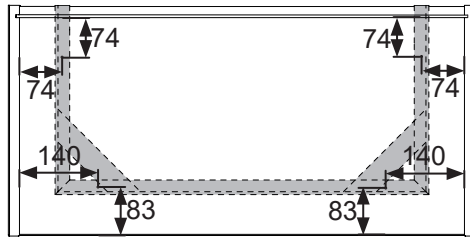
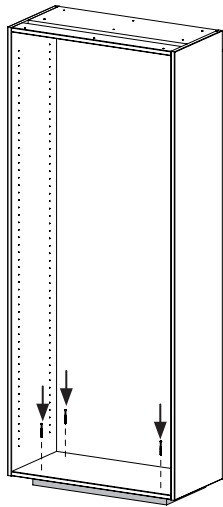
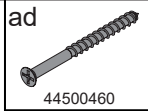

En option : En cas de joint de corps

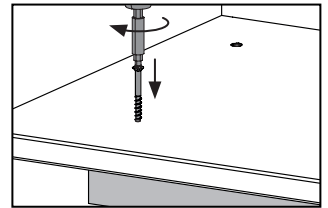
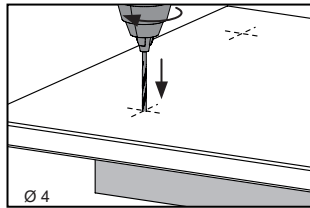
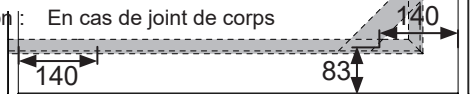

**Toutes les mesures sont en millimètres!**

### 5.3 Ajuster

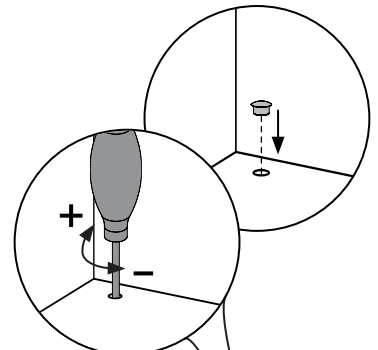
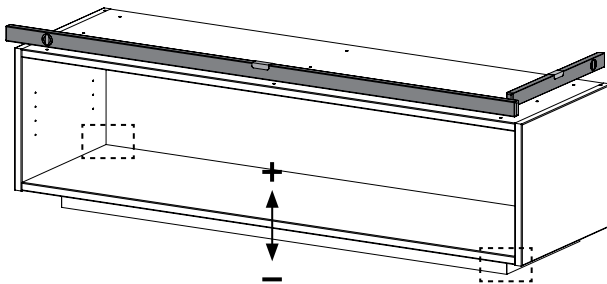
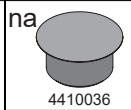

En option :

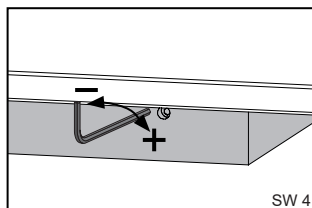
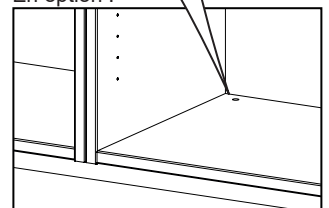



- 5.4 En option : Pour corps tiroir sur roulettes  
Aligner le corps à l'aide du vérin

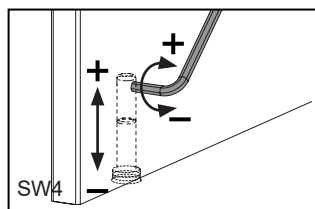
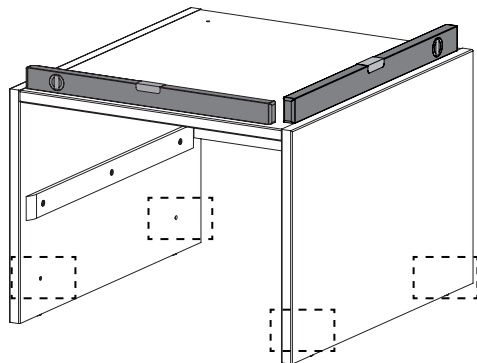

## 6. Mise en place

### 6.1 Corps plateforme

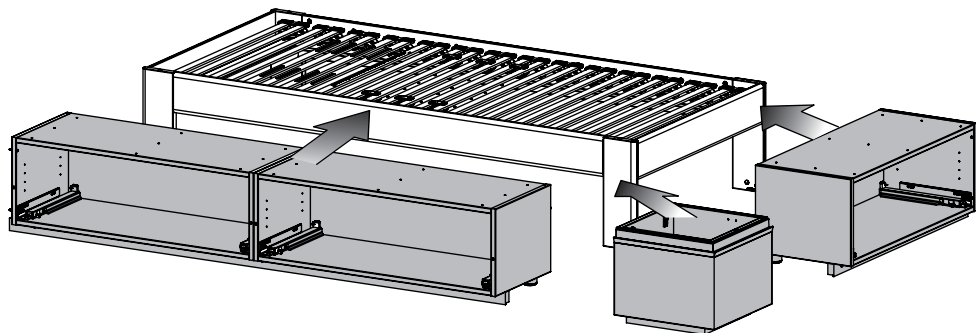

## 6.2 Visser le corps d'angle

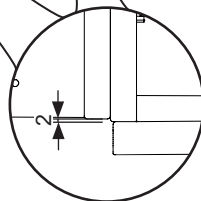
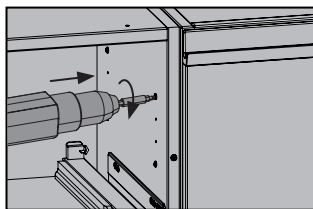
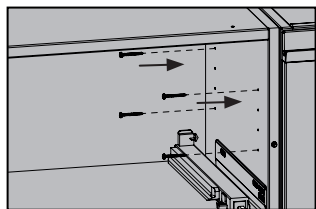
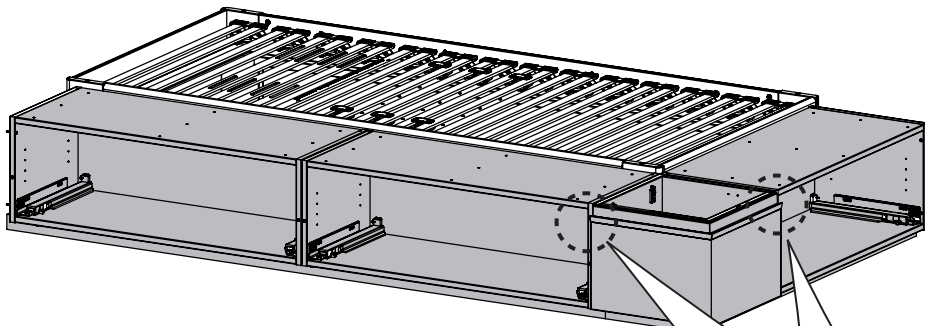

Toutes les mesures sont en millimètres!

## 6.3 Visser les corps au lit

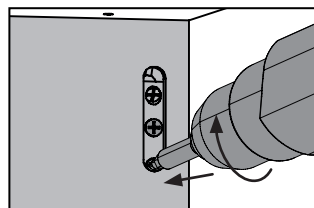
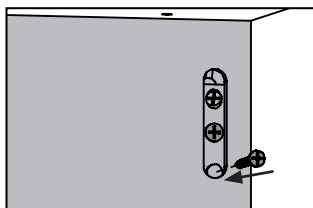
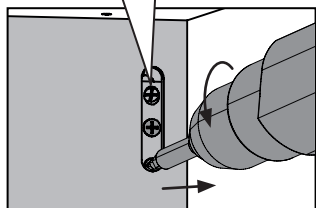
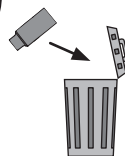
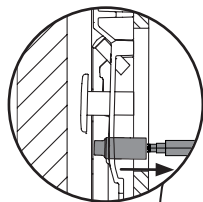
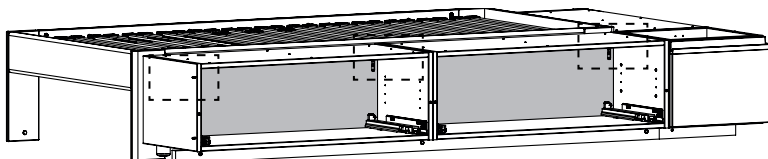
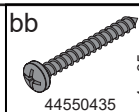

## 7. sécurité anti-bascule

### 7.1.1 Montage sécurité anti-bascule

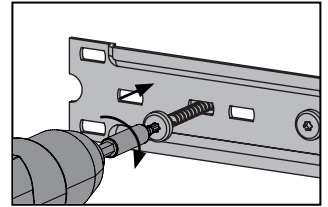
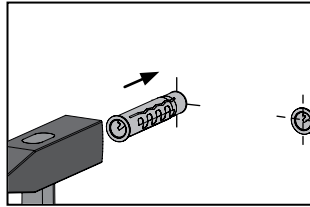
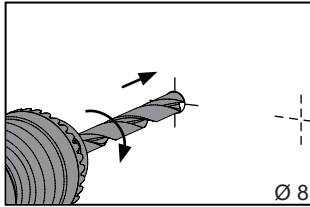
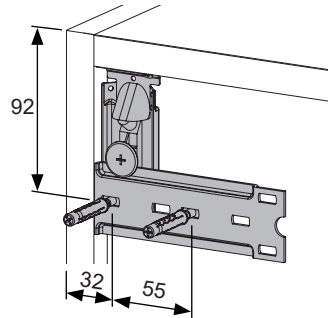
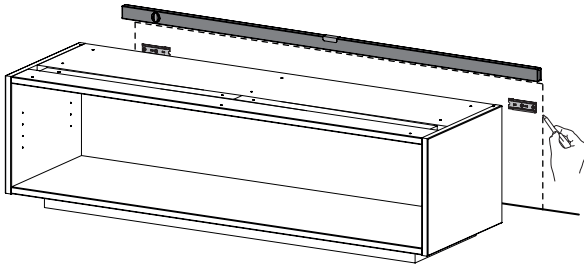
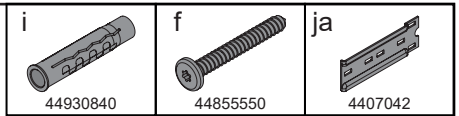

Toutes les mesures sont en millimètres!

### 7.1.2 Accrocher le corps

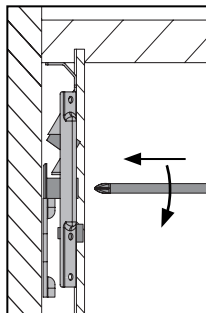
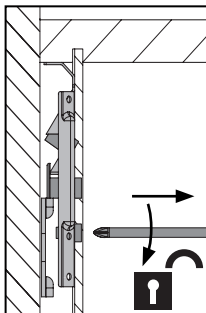
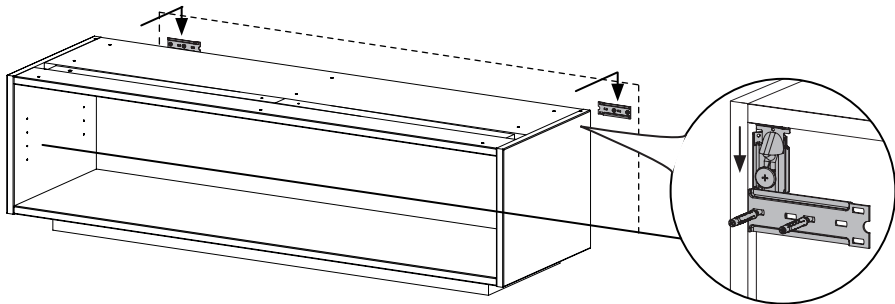

### 7.1.3 Réglages de la ferrure

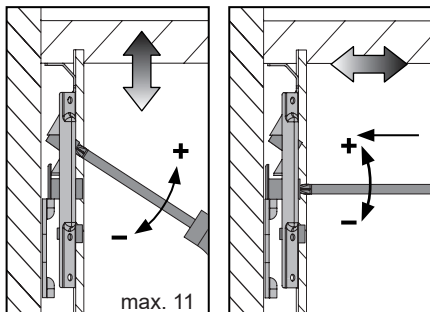
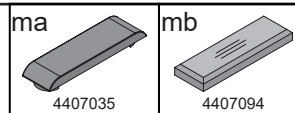

max. 11

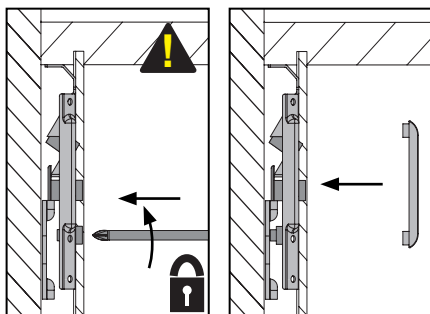
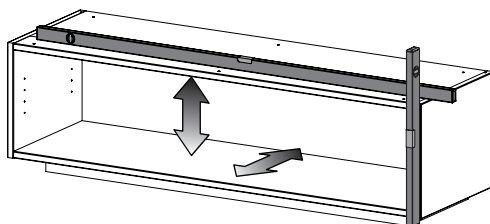

En option :



Couvercle en bois uniquement pour rayonnage ouvert

Toutes les mesures sont en millimètres!

### 7.2 En option : Pour corps tiroir sur roulettes sans élément à poser Variante avec panneau de finition

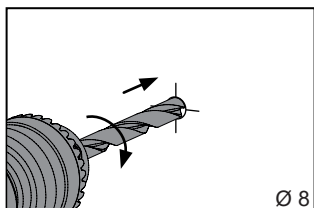
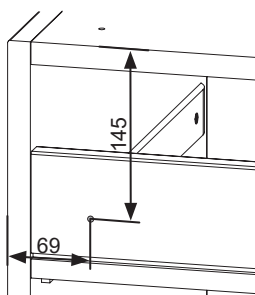
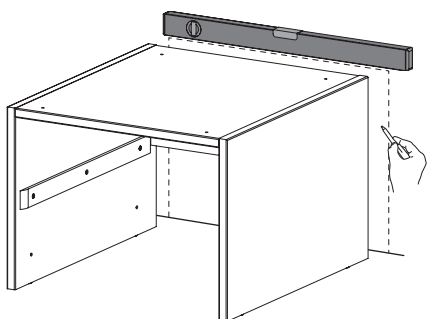
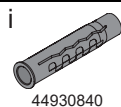
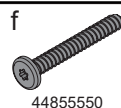

Ø 8

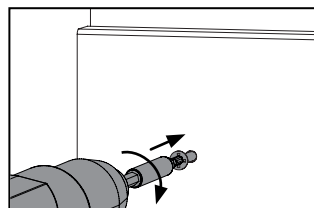
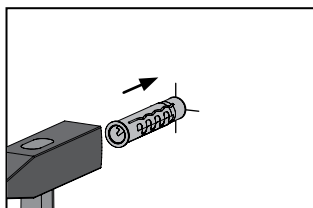

Toutes les mesures sont en millimètres!

### 7.3 En option : Pour coffre

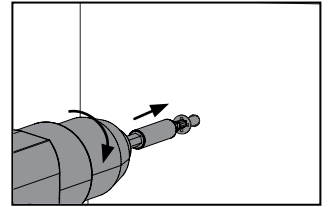
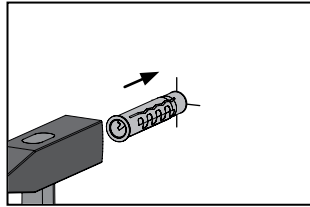
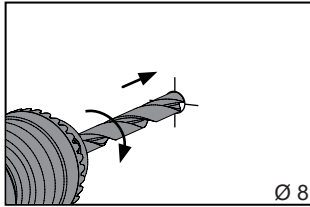
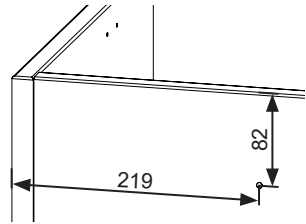
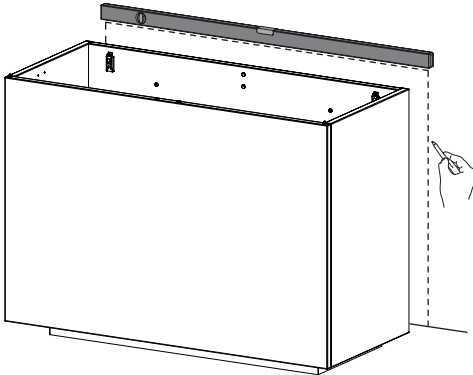
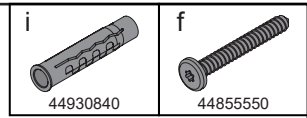

Toutes les mesures sont en millimètres!

## 8. ferrure de suspension

### 8.1 Montage ferrure de suspension

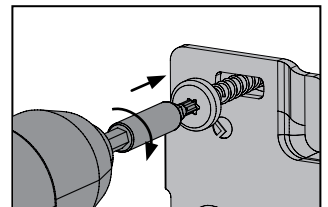
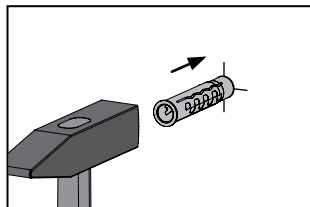
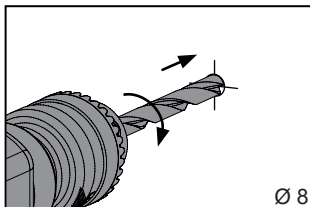
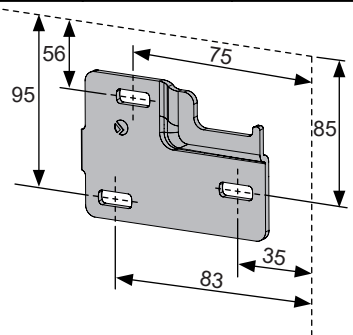
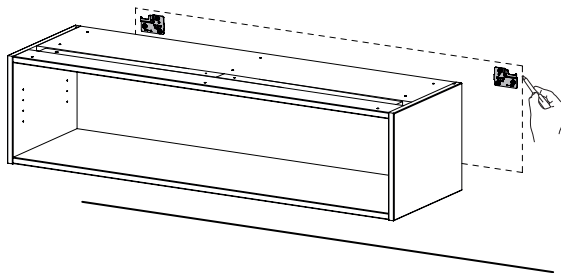
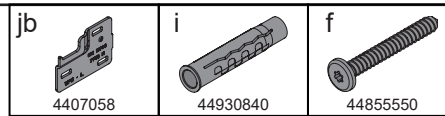

Toutes les mesures sont en millimètres!

## 8.2 Accrocher et aligner corps

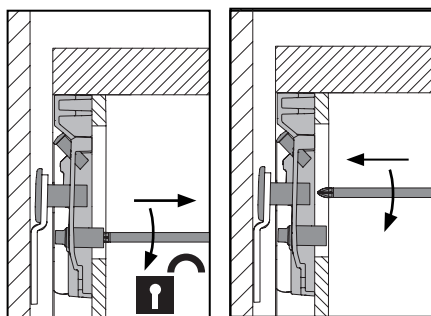
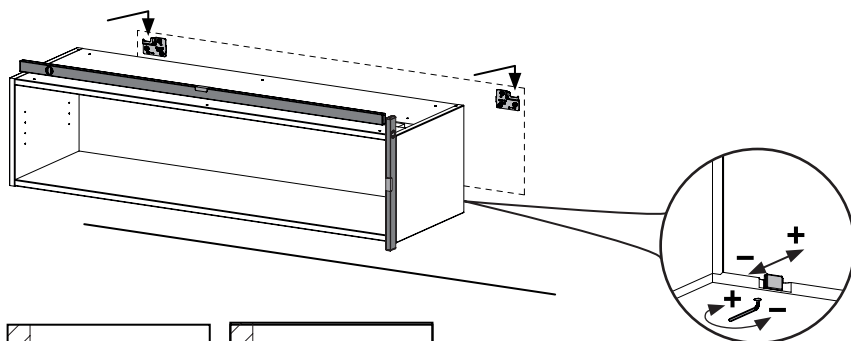

### **HINWEIS**

• Charge : 120 kg max.

## 8.3 Réglages de la ferrure

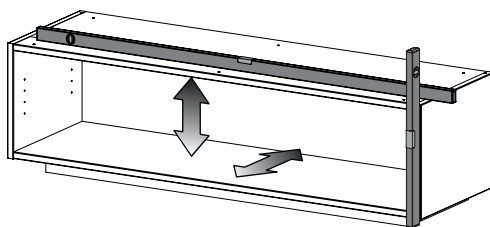
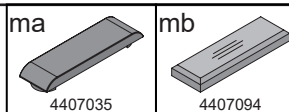
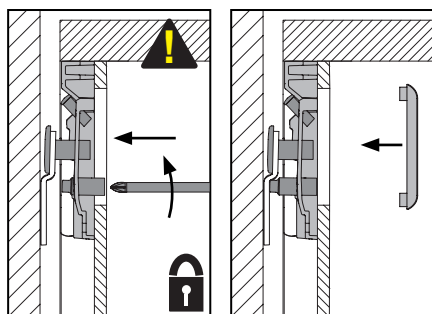
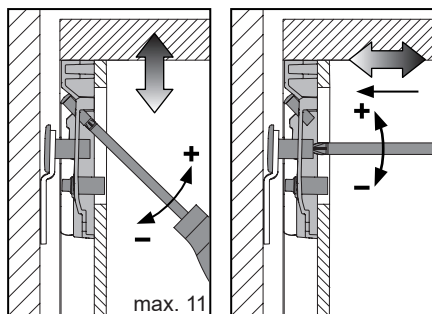

En option :

Couvercle en bois  
uniquement pour ray-  
onnage ouvert

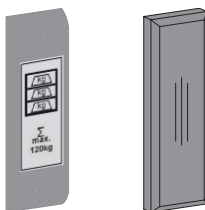

Toutes les mesures sont en millimètres!

## 9. Montage des caches latéraux et du panneau de finition

### 9.1 Cache latéral

ab

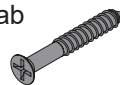

44500435

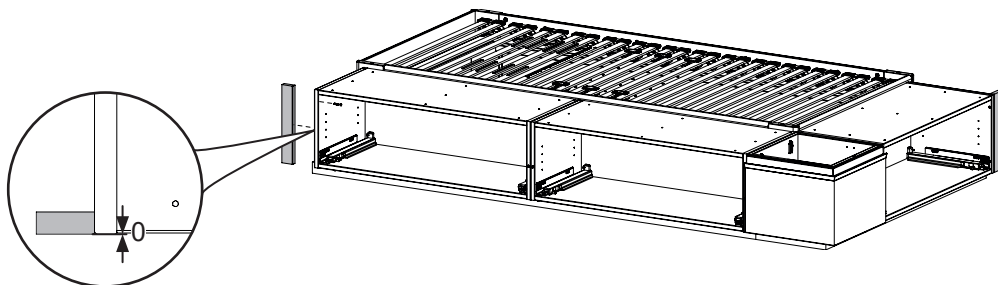

#### **! HINWEIS**

- Les caches doivent être adaptés au mur.

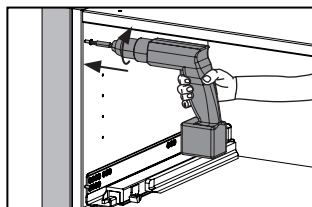
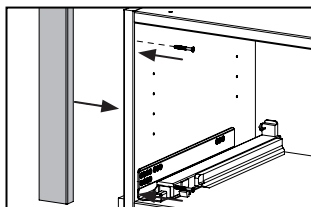

### 9.2 Raccorder les panneaux de finition



4406061

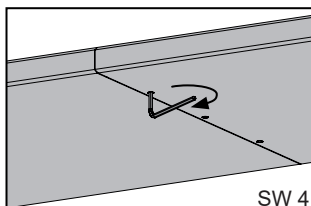
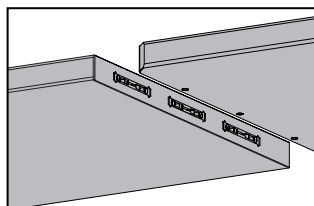
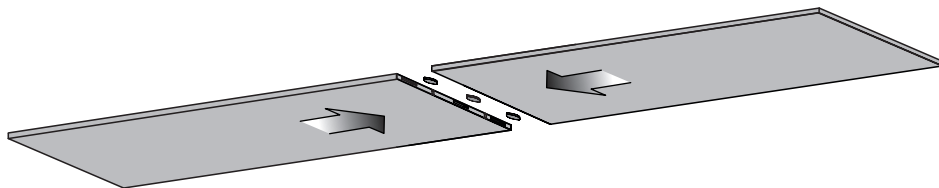

SW 4

### 9.3 Monter le panneau de finition

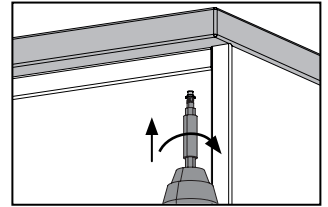
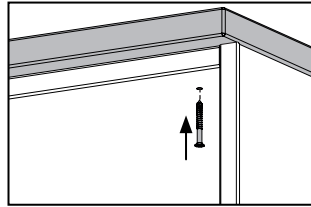
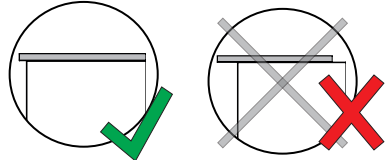
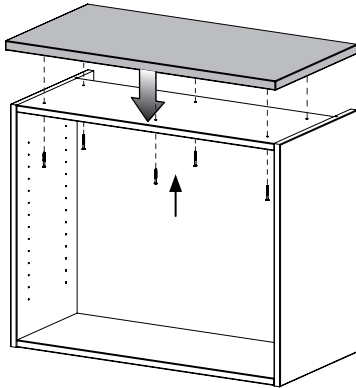
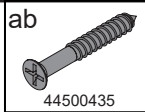

### 10. Monter les roulettes

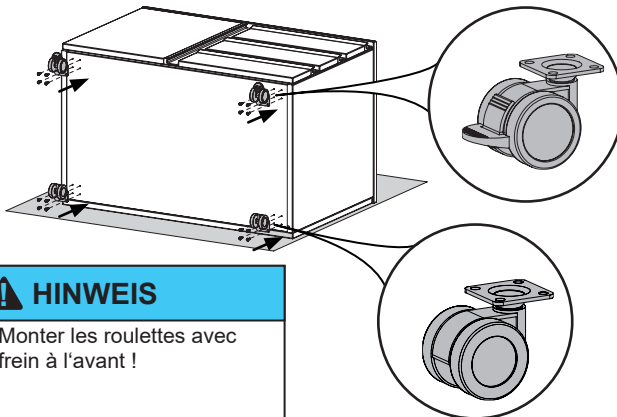
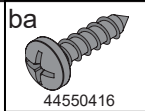

#### HINWEIS

- Monter les roulettes avec frein à l'avant !

#### HINWEIS

- mettre une protection
- Le support doit être propre et exempt d'objets pointus ou tranchants.

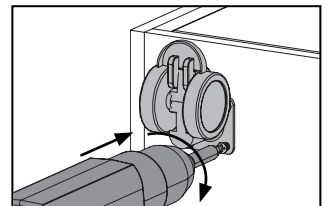
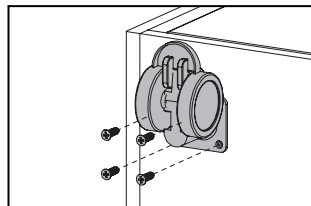
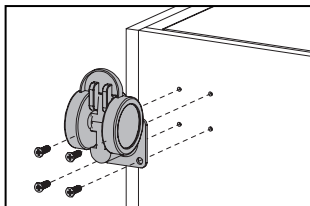



# 11. Composants façade

## 11.1 Tiroir

charge Décrocher

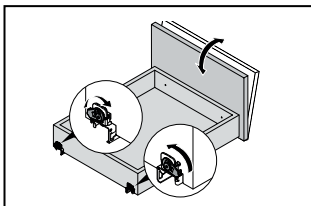
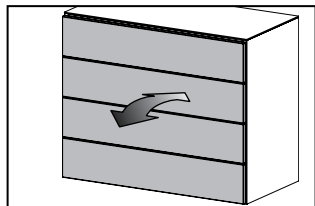
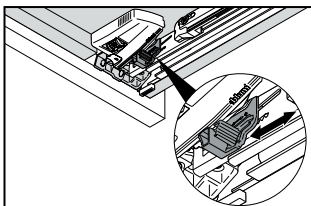
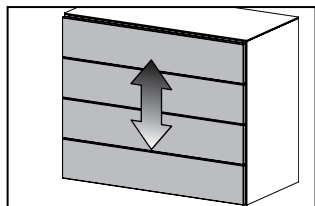
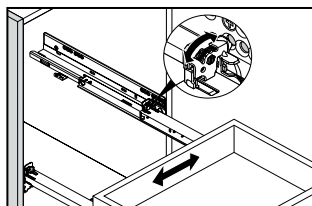
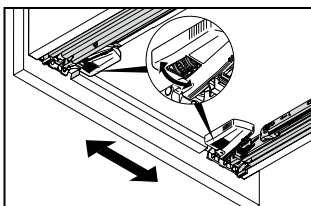
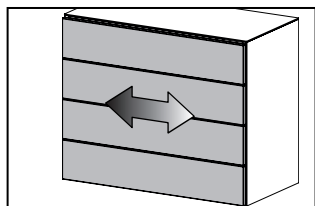
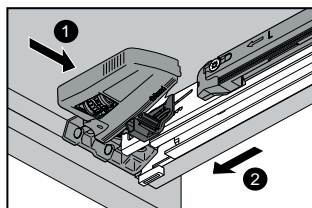
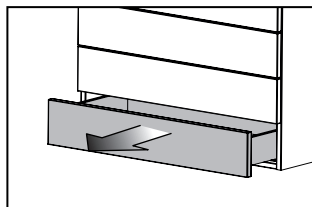
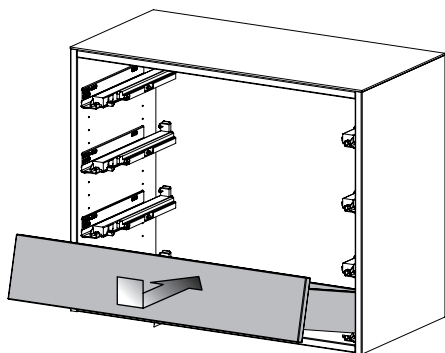

si variante Tip-On

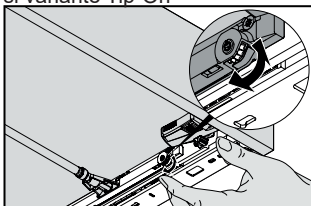
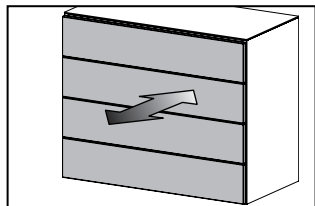

## 11.2 Régler position de l'abattant

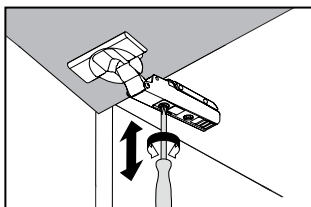
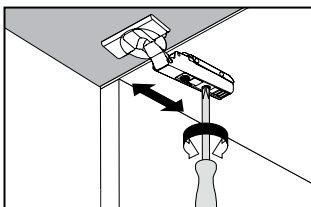
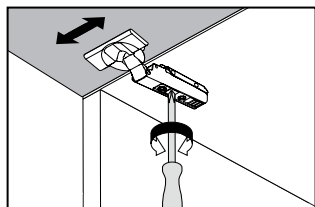
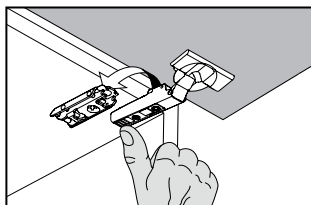
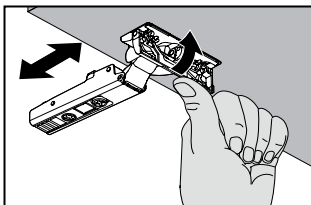
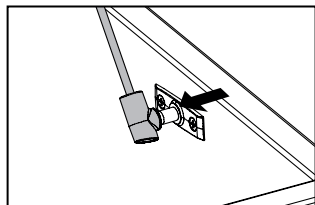
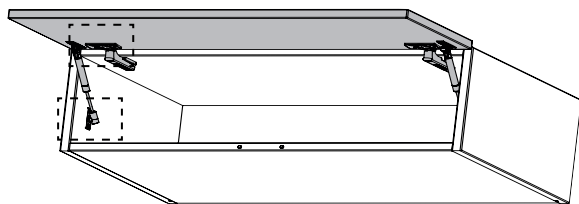

## 11.3 Porte pivotante

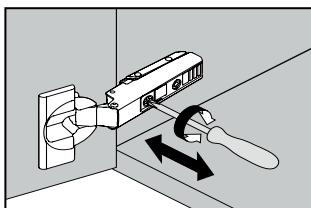
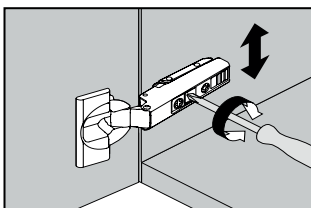
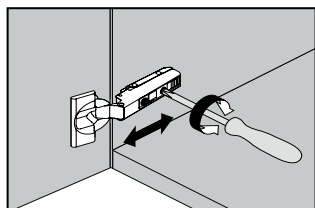
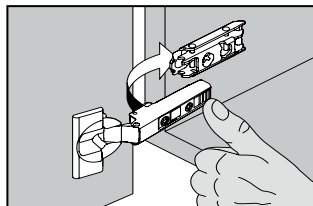
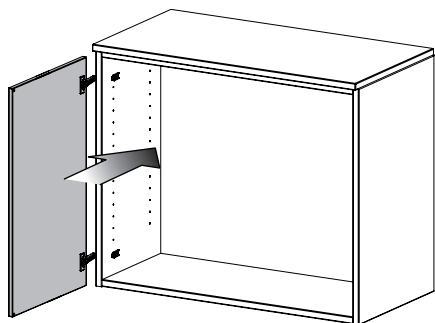

### 11.4.1 Roulette

Monter les roulettes

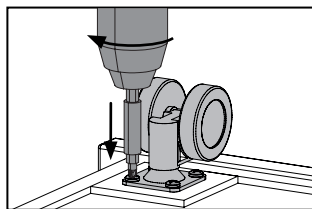
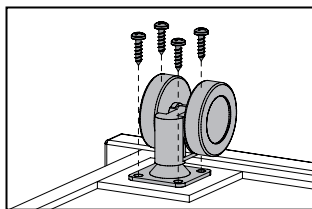
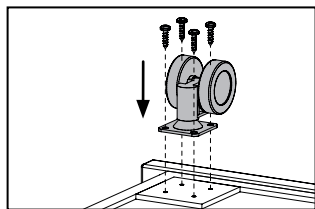
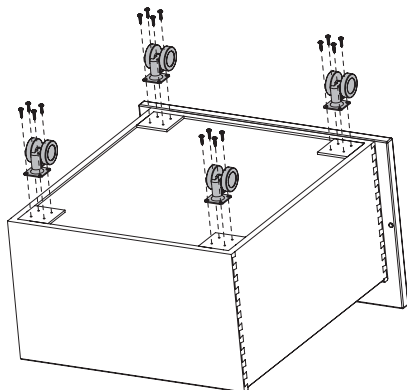
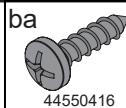

### 11.4.2 En option : En cas de grande distance de la façade

Monter la plaque d'écartement

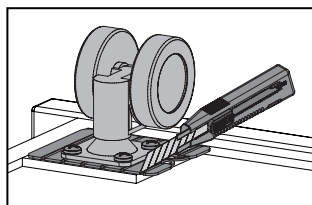
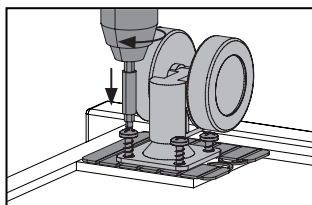
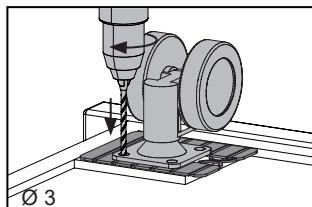
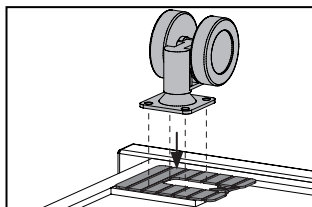
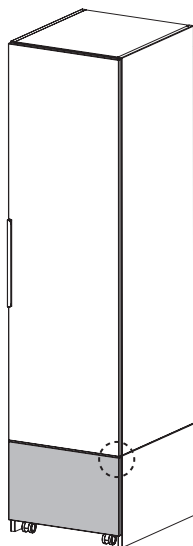
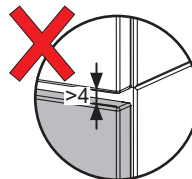
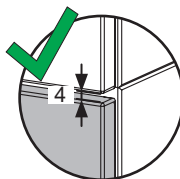
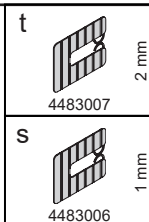

Toutes les mesures sont en millimètres!

### 11.4.3 Régler le tiroir sur roulettes

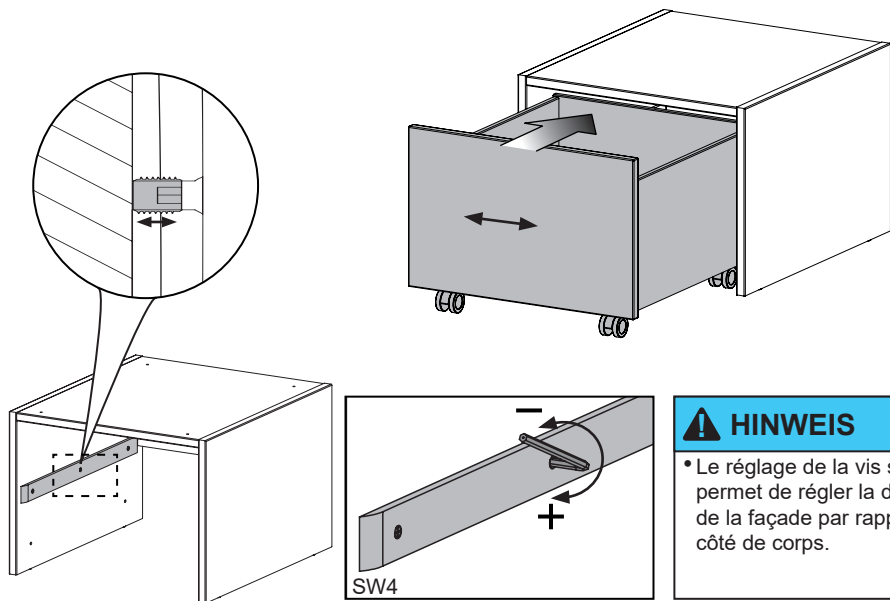

#### **HINWEIS**

- Le réglage de la vis sans tête permet de régler la distance de la façade par rapport au côté de corps.

### 11.5 Accrocher le panneau mural

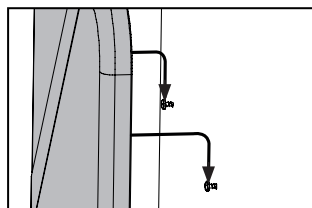
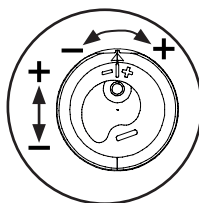
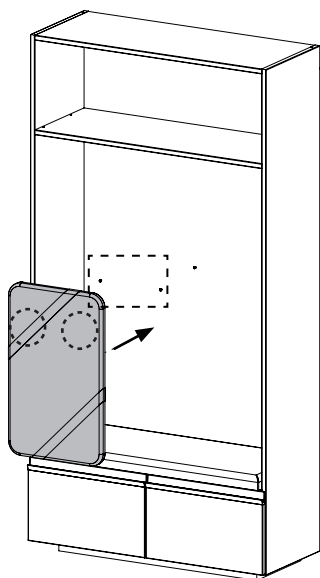

## 11.6 Allumer et éteindre la lumière

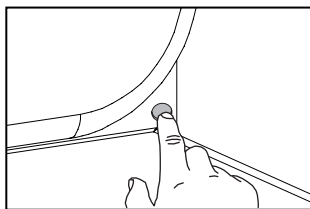
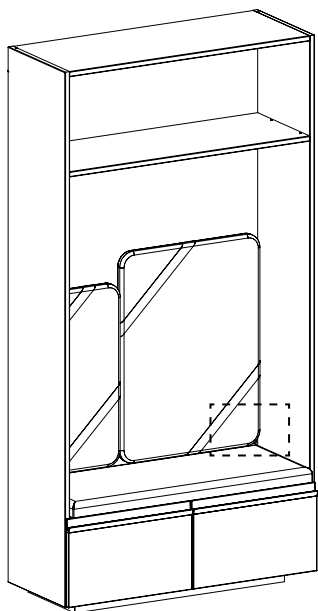

## 12. Compartimentages intérieurs

### 12.1 Compartimentage en T

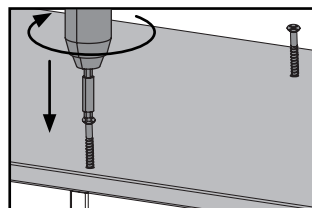
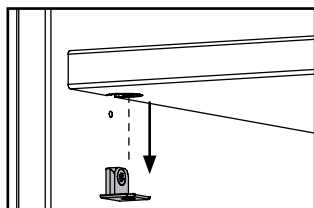
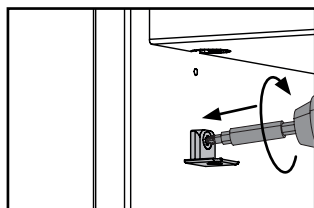
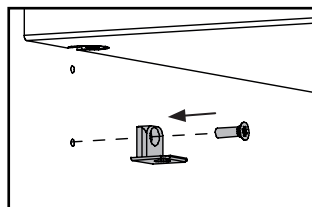
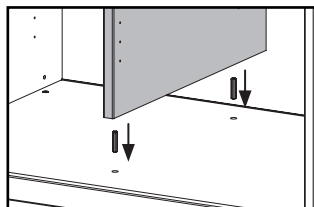
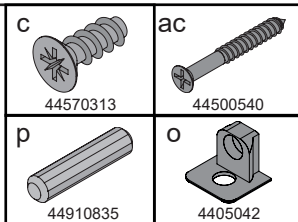
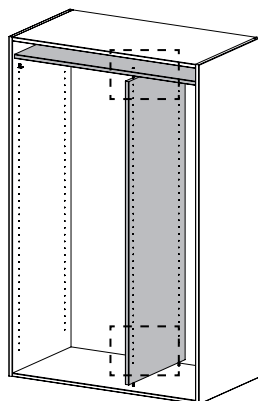

## 12.2 Tringle à habits

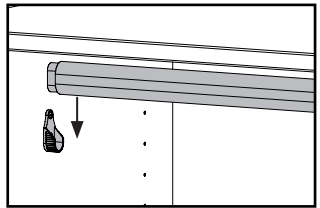
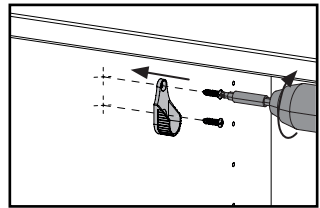
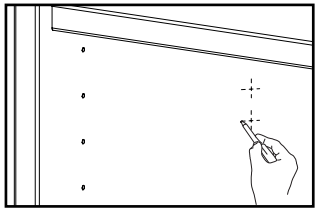
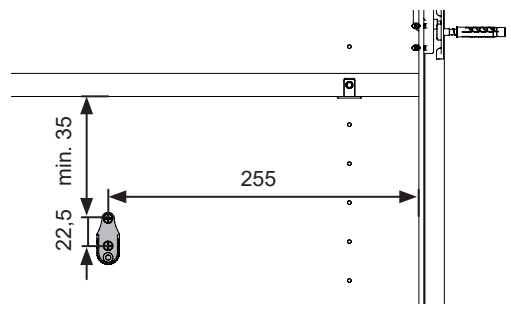
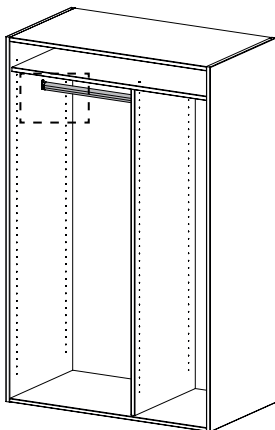
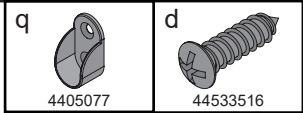

**Toutes les mesures sont en millimètres!**

## 12.3 étagère avec tringle à habits

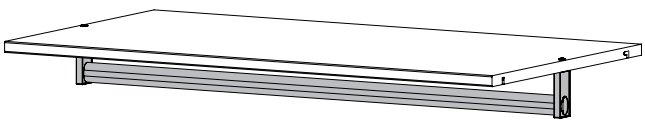
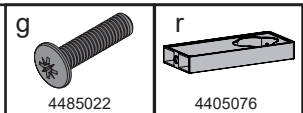

**Hinweis**

- L'étagère avec trou de perçage est prévue pour le montage de la tringle à habits.
- Les encoches pour les taquets doivent se situer sur la face inférieure.

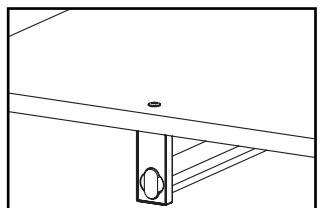
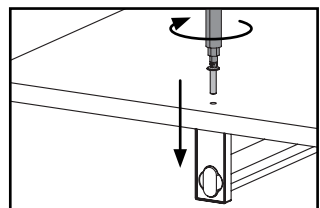
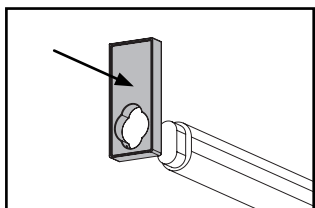

## 12.4 Compartiment de sécurité

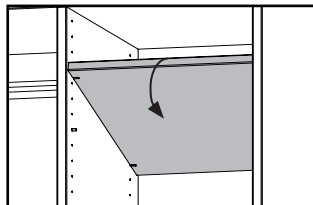
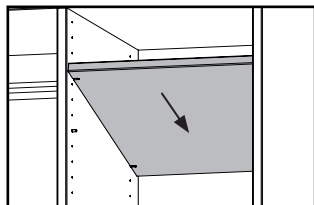
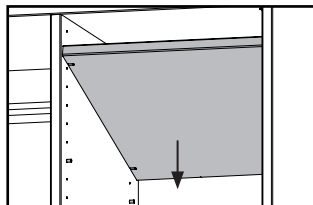
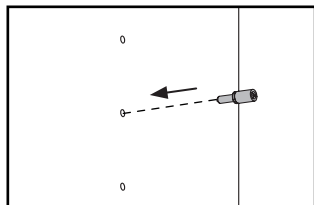
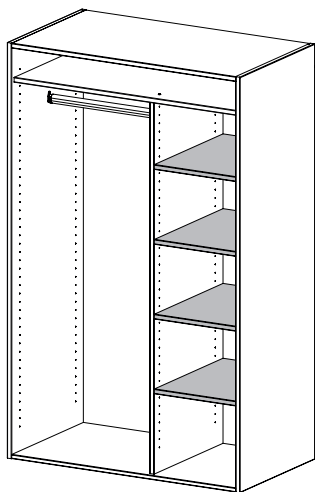
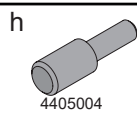

# TEAM 7

## **TEAM 7 Natürlich Wohnen GmbH**

Braunauer Str. 26  
4910 Ried im Innkreis, AUSTRIA

**Montagehotline: +43/7752-977321**

[www.team7-home.com](http://www.team7-home.com)

Sous réserve de modification, d'erreur et de coquille

### Droit d'auteur

L'œuvre et toutes ses parties sont protégées par le droit d'auteur. Toute utilisation, en dehors des limites strictes prévues par la loi sur le droit d'auteur, faite sans le consentement de l'entreprise TEAM 7 GmbH, est illicite et passible de poursuites judiciaires. Ladite clause s'applique notamment à la reproduction, au microfilmage, ainsi qu'à la sauvegarde et au traitement par voie électronique.



# TEAM 7

Dokument für  
die qualifizierte  
Fachkraft!



## Manuale montaggio

# *Kids*

## Sistema di corpi

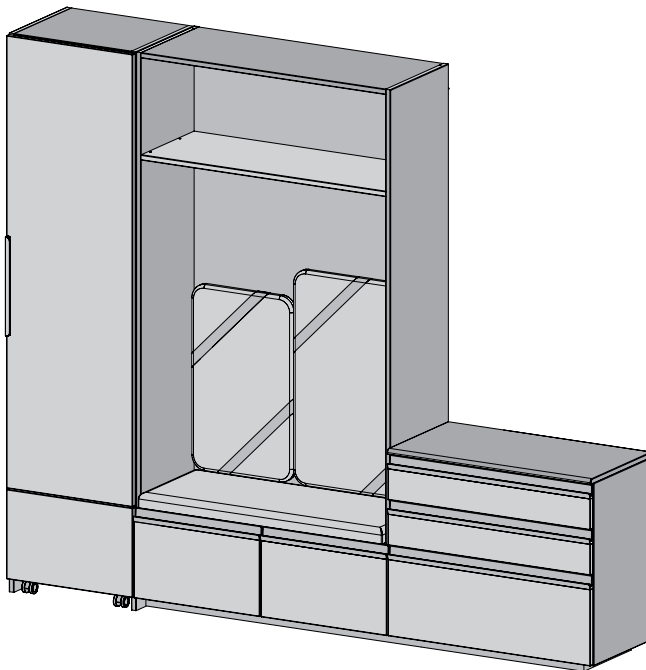

# IT

122022  
TD284010A

Nach der Montage  
zur Aufbewahrung für  
unsere Kunden!

## CLIMA DELL'AMBIENTE

- Il clima ambiente ideale per persone, piante e mobili in legno naturale è:

**Umidità atmosferica rel. 40 - 60% e una  
Temperatura ambiente: fra 18 e 23° Celsius.**

- In caso di superamento in eccesso o in difetto di questi valori per lungo tempo, si verificano ritiri o rigonfiamenti. In seguito possono verificarsi svirgolamento, crepe, scollamento di fughe e irruvidimento delle superfici.

## MANUTENZIONE

- Per le istruzioni di manutenzione (cura di pannelli in legno naturale, pelle, stoffa, Stricktex, pietra, vetro, Metallo, ceramica feltro e piani di lavoro) consultare il sito web di TEAM 7.

- Troverete importanti caratteristiche dei mobili in legno naturale TEAM 7 anche nel nostro pass assistenza e qualità qui:

<https://www.team7-home.com/at/de/service/service-und-guetepass/>



## DOCUMENTAZIONE

- Conservare accuratamente tutta la documentazione relativa all'acquisto di questo mobile, anche oltre la garanzia di due anni obbligatoria per legge.
- Quando si richiedono parti di ricambio o di integrazione, la documentazione d'acquisto facilita la ricerca di informazioni precise sul prodotto acquistato.
- In caso di danni ai mobili causati dal trasporto, è assolutamente necessario produrre foto della parte danneggiata nell'imballaggio originale.

## ATTENZIONE

- Il materiale accluso per il fissaggio alla parete è idoneo per pareti in calcestruzzo, mattoni pieni e mattoni forati alti\*. Per altri tipi di parete, utilizzare tasselli speciali.  
\* per i mattoni forati, non usare la percussione!
- Il tecnico deve controllare l'idoneità del sottofondo e verificare se i mezzi usati per il fissaggio sono in grado di sopportare le forze generate! Scegliere eventualmente mezzi di fissaggio diversi che siano idonei per le caratteristiche della parete!
- TEAM 7 non si assume alcuna responsabilità del prodotto in caso di mancato rispetto di questa avvertenza!

## ATTENZIONE

- Tutti i lavori elettrici devono essere eseguiti da uno specialista adatto!
- Non aprire mai un alimentatore. Pericolo di morte!
- La somma dei watt dei faretto non deve essere superiore alla potenza in watt del trasformatore o dell'unità radio.
- Se è previsto un foro passacavi, praticarlo con sega a gattuccio

## Indice

<b>1.</b>	<b>Controlli ambiente / progettazione</b>	<b>5</b>
<b>2.</b>	<b>Panoramica dei tipi</b>	<b>6-7</b>
<b>3.</b>	<b>Assemblaggio corpo</b>	<b>8-13</b>
<b>4.</b>	<b>Possibilità di collegamento del corpo</b>	<b>14</b>
4.1	Unire i corpi	14
4.2	Aufsatzkorpus	14
<b>5.</b>	<b>Montaggio zoccolo</b>	<b>15-17</b>
5.1	Zoccolo rientrante	15
5.2	Montaggio dello zoccolo in caso di poco spazio	15-16
5.3	Allineare	16
5.4	Corpo con serrandina: regolatore altezza	17
<b>6.</b>	<b>Posizionamento</b>	<b>17-18</b>
<b>7.</b>	<b>Antiribaltamento</b>	<b>19-21</b>
7.1	montaggio dispositivo antiribaltamento	19-20
7.2	Antiribaltamento corpo con serrandina	20
7.3	Antiribaltamento cassettoni sotto rete	21
<b>8.</b>	<b>montaggio meccanismo di sospensione</b>	<b>21-22</b>
7.1	montaggio meccanismo di sospensione	21
7.2	Appendere e allineare il corpo	22
7.3	Regolazioni del meccanismo	22
<b>9.</b>	<b>Montaggio pannelli laterali e top</b>	<b>23-24</b>
9.1	Fascia laterale	23
9.2	Collegare i piani top	23
9.3	Montare il top	24
<b>10.</b>	<b>Montare ruotine</b>	<b>24</b>
<b>11.</b>	<b>Componenti frontali</b>	<b>25-28</b>
11.1	Cassetto	25
11.2	Ribaltina	26
11.3	Anta battente	26
11.4	Cassetto su ruote	27-28
11.5	Pannello a parete	28
11.6	Accensione e spegnimento della luce	29
<b>12.</b>	<b>Divisioni interne</b>	<b>29-31</b>
12.1	Suddivisione T	29
12.2	Asta appendiabiti	30
12.3	Piano con asta appendiabiti	30
12.4	Vano di sicurezza	31

## Attrezzi

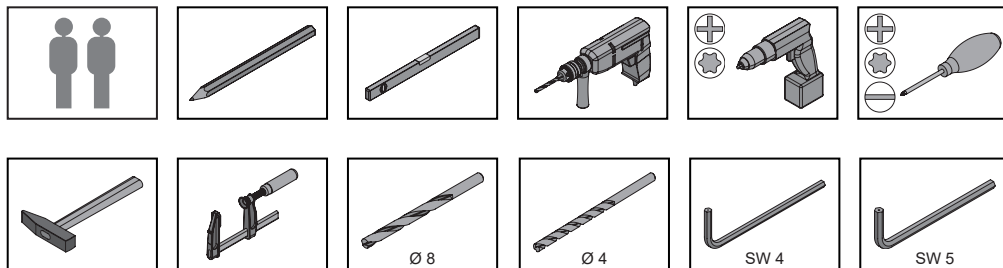

## Ferramenta

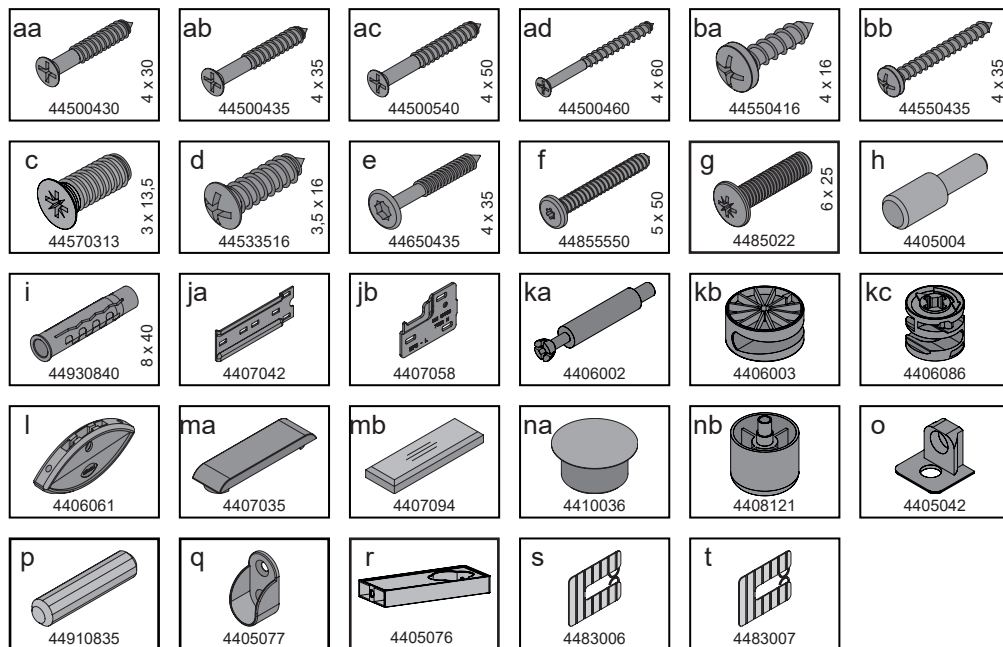

# 1. Controllo ambiente / progettazione

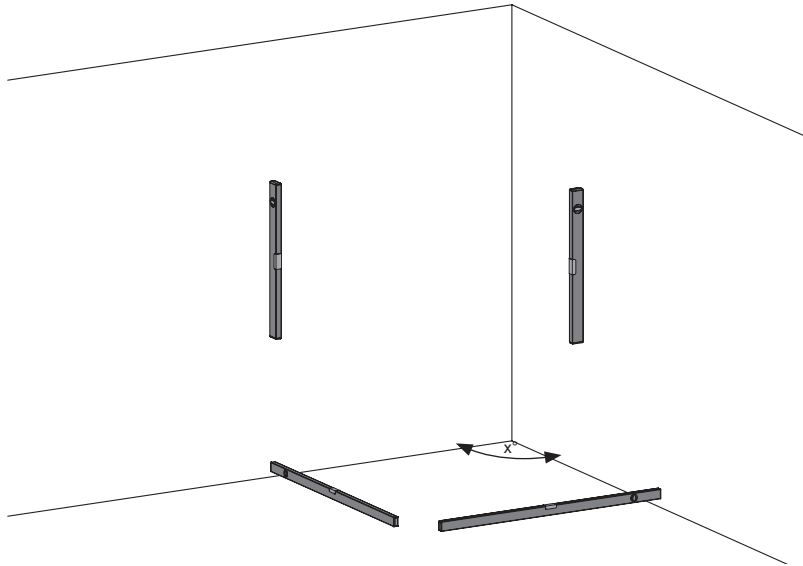

Appunti

.....

.....

.....

.....

.....

.....

## 2. Panoramica dei tipi

### Basiskorpus

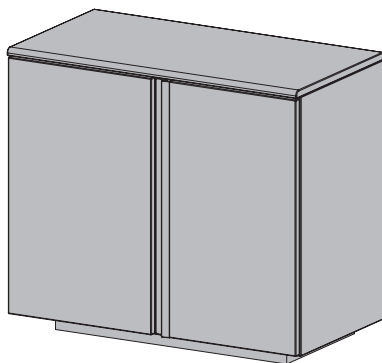
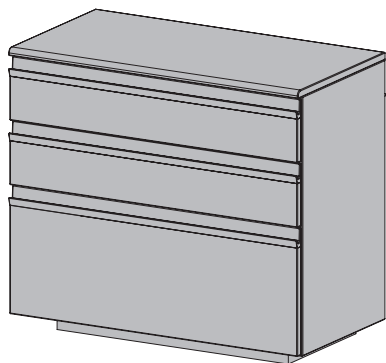

### Corpo piattaforma

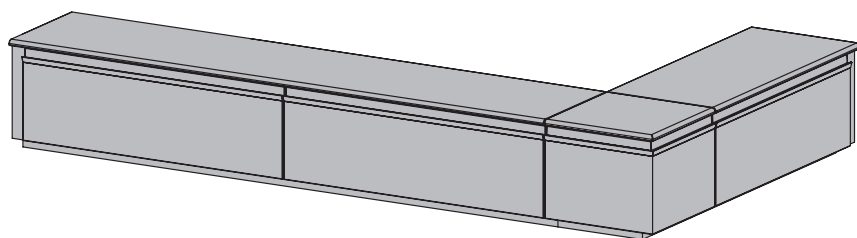

### Cassettone testata letto

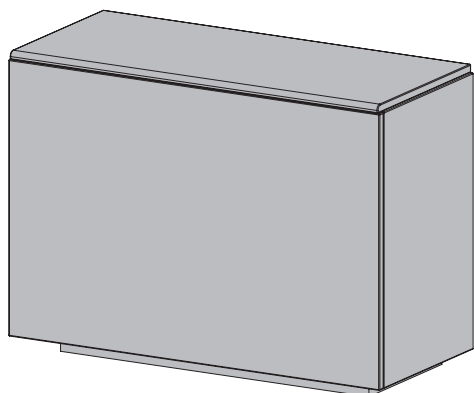

Nicchia con seduta

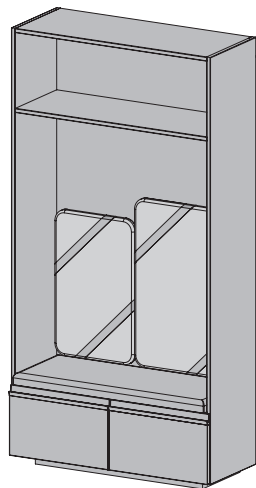

Corpo con serrandina

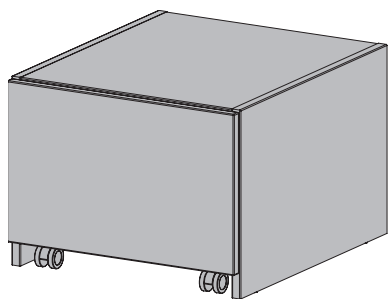

Contenitore su ruote

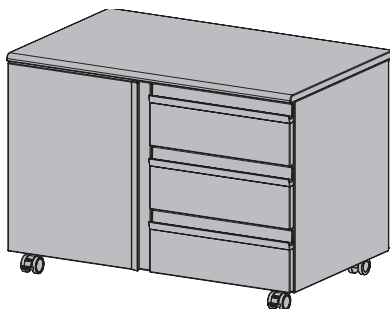
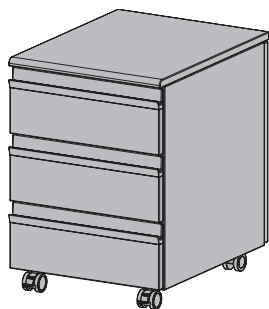

### 3. Opzionale: Assemblaggio corpo

#### 3.1 corpo smontato

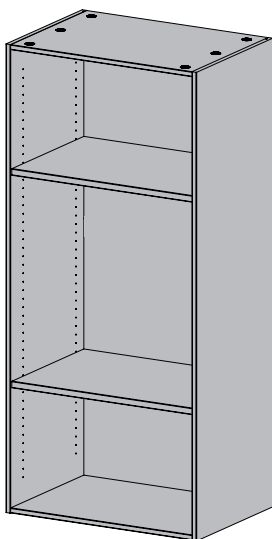

#### 3.2 Avvitare i bulloni

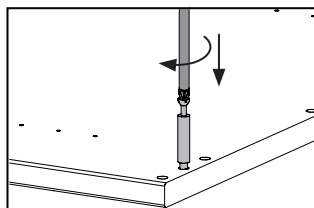
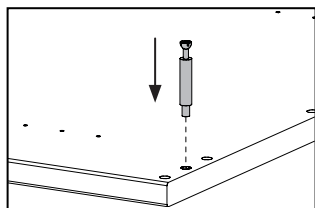
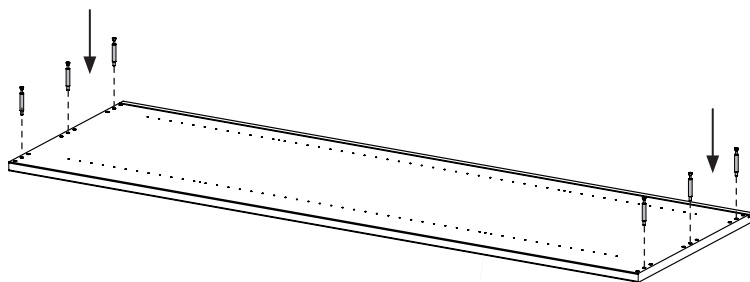
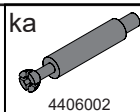



### 3.3 Inserire la scatola

kb



4406003

kc



4406086

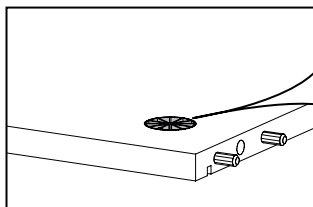
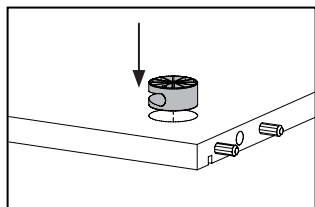
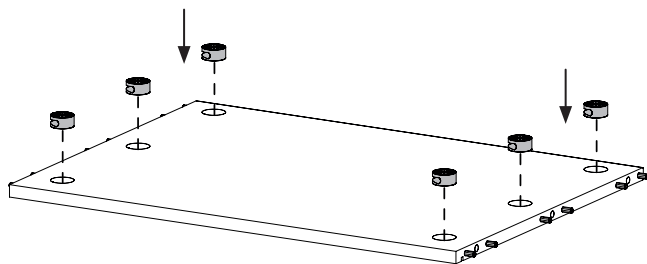

### 3.4 Fissare ripiano superiore e inferiore

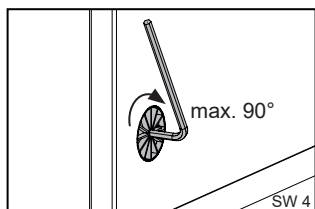
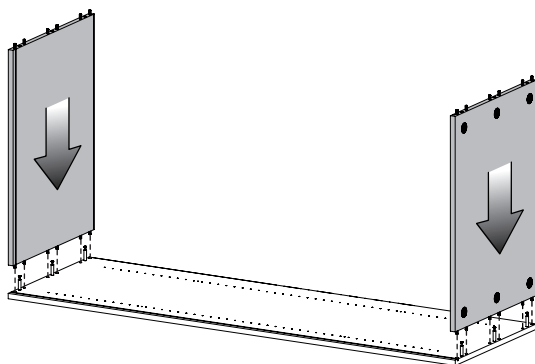

### 3.5 Opzionale: Con nicchia con seduta

#### 3.5.1 Svitare il sedile imbottito dal ripiano intermedio

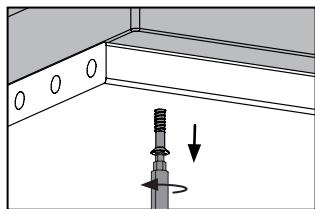
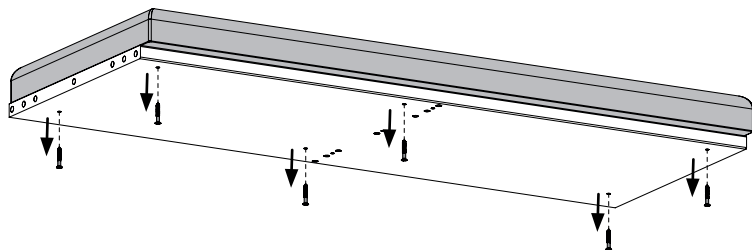

#### 3.5.2 Installare ripiano intermedio

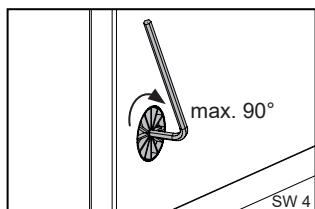
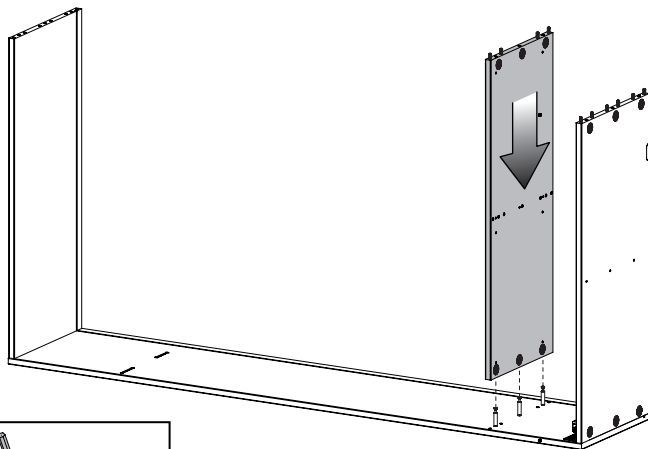

### 3.6 Inserire lo schienale

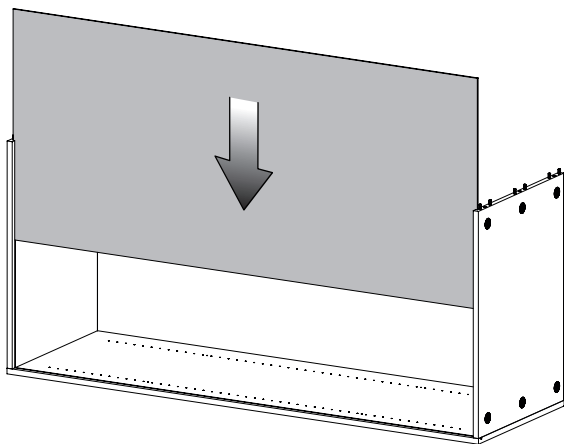

### 3.7 Fissare lato esterno

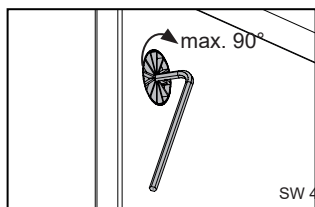
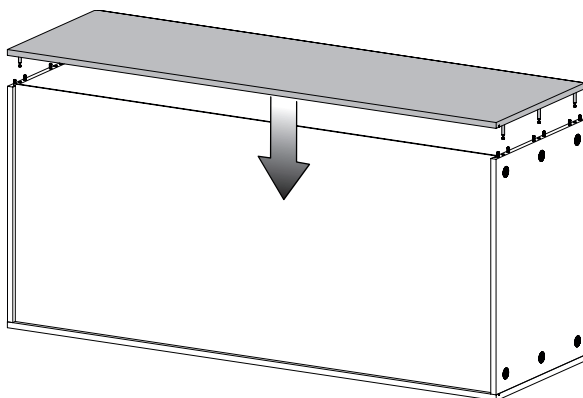

### 3.8.1 Opzionale: Con nicchia con seduta

Avvitare il lato centrale al ripiano inferiore e al ripiano intermedio

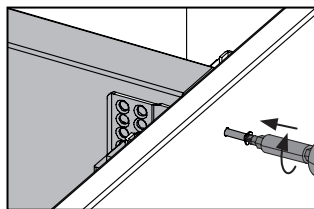
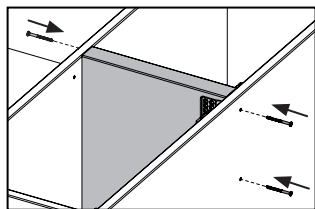
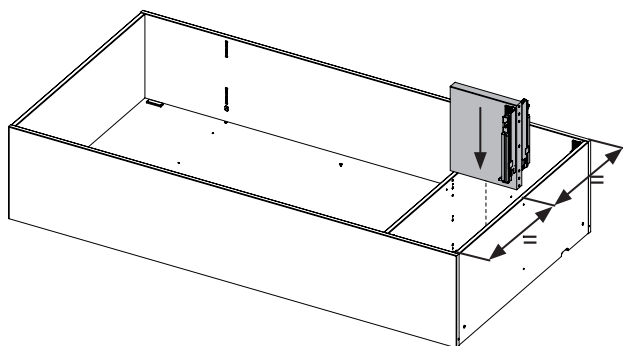

### 3.8.2 Avvitare nuovamente il sedile imbottito al ripiano intermedio

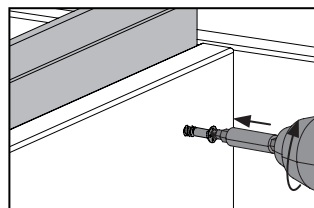
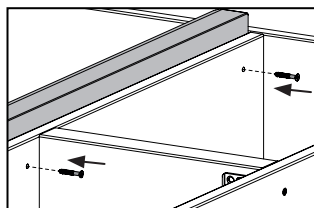
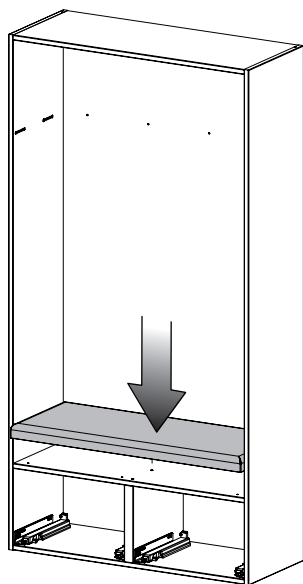

### 3.8.3 Avvitare la parete posteriore

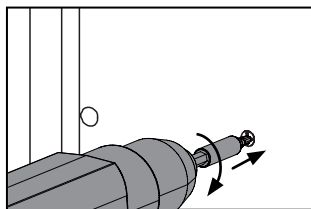
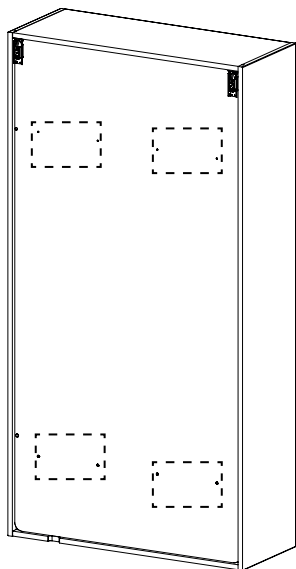

### 3.8.4 Installare ripiano intermedio

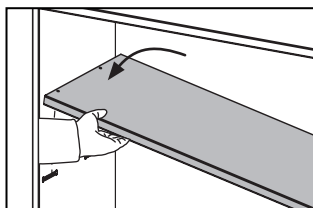
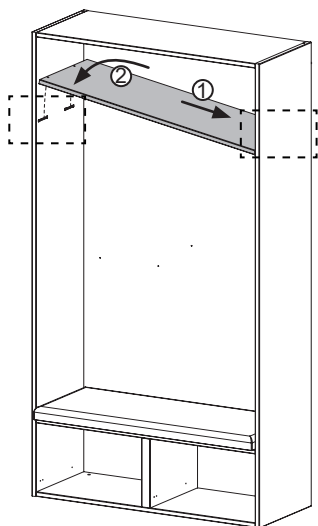

#### **⚠ HINWEIS**

- Agganciare sempre prima il ripiano a destra per evitare di incastrare il cavo.

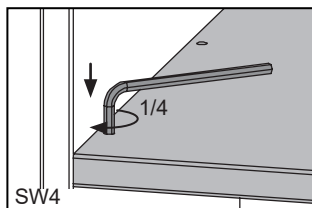

## 4. Possibilità di collegamento del corpo

### 4.1 Unire i corpi

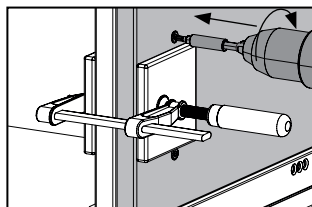
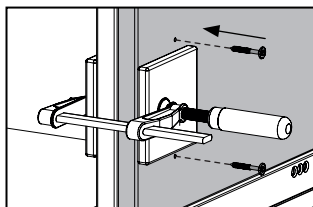
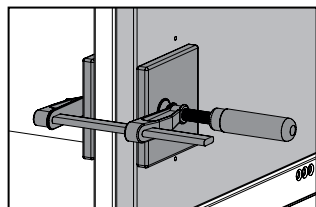
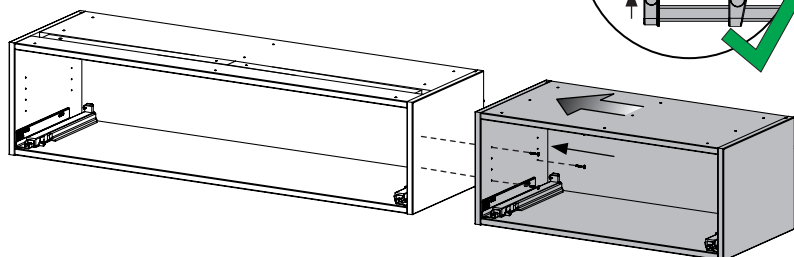

### 4.2 Opzionale: Con corpo con serrandina

Avvitare il corpo sopra

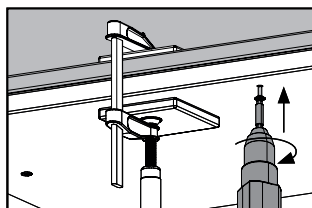
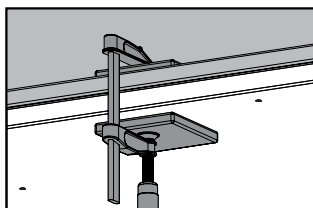
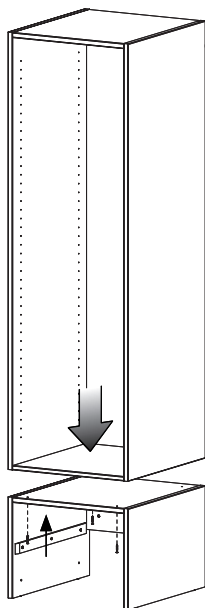

#### **! HINWEIS**

- Avvitare le viti con cautela.
- Allineare lateralmente e frontalmente a filo.

#### **! HINWEIS**

- Opzionale possibile anche solo con top. Per il montaggio si veda il punto 9.
- Antiribaltamento per corpo sopra. Per il montaggio si veda il punto 7.

## 5. Varianti zoccolo

### 5.1 Telaio zoccolo rientrante

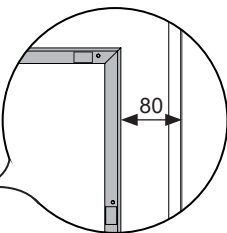
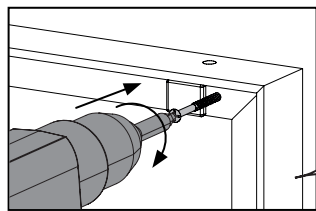
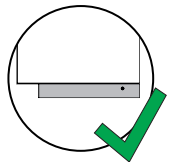
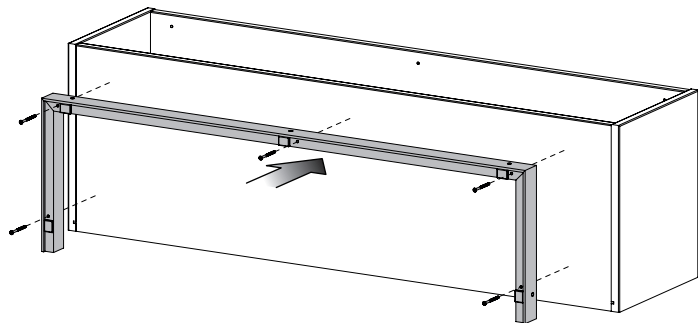
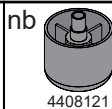
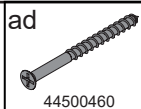

Opzionale: Per corpo giuntato di testa

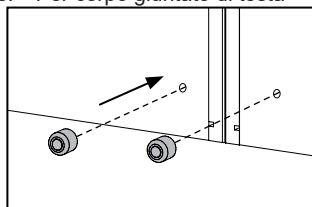

Alle Maße in Millimeter

### 5.2 Montaggio su zoccolo in caso di problemi di spazio

#### 5.2.1 Posizionare il corpo

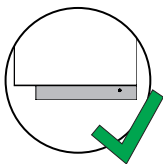
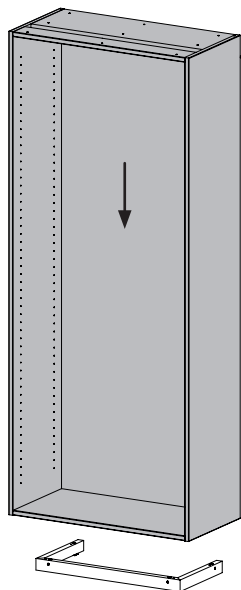
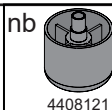

Opzionale: Per corpo giuntato di testa

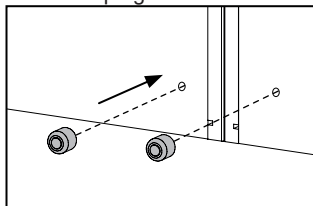

#### **HINWEIS**

- Le viti successivamente sono visibili. Montare lo zoccolo dall'interno solo se assolutamente necessario!

### 5.2.2 Avvitare il corpo con lo zoccolo

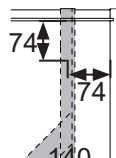
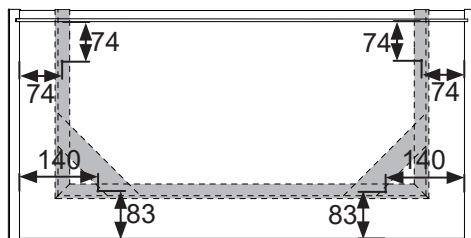
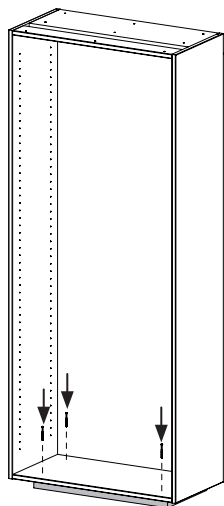
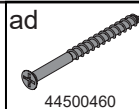

Opzionale: Per corpo giuntato di testa

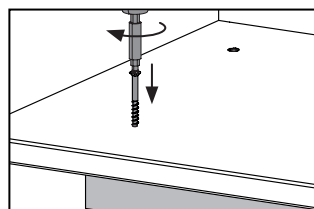
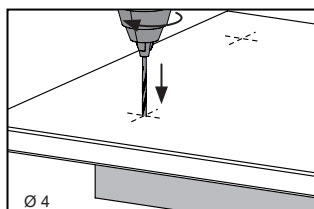
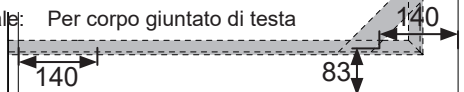

**Tutte le misure sono in millimetri!**

### 5.3 Allineare

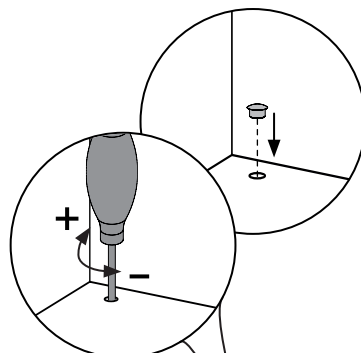
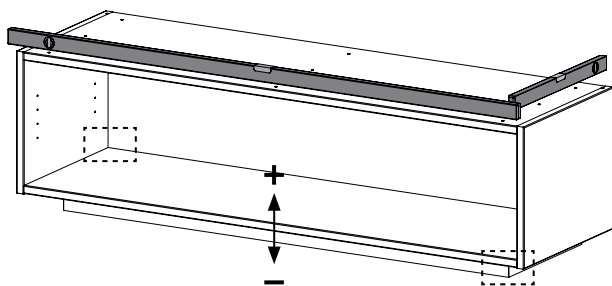
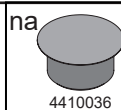

Opzionale:

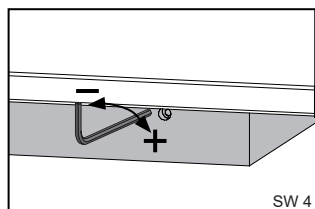
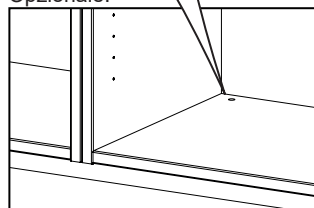



- 5.4 Opzionale: Con corpo con serrandina  
Allineare il corpo mediante i regolatori di altezza

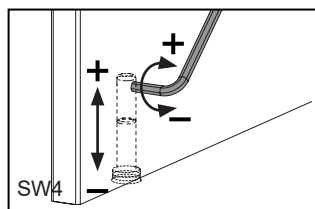
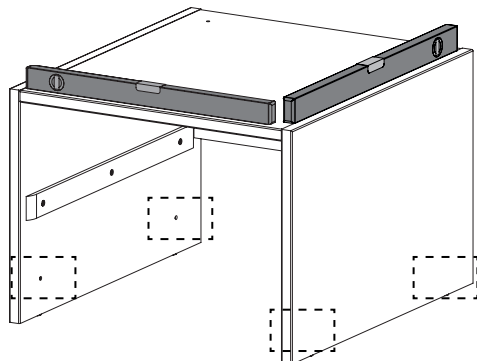

## 6. Posizionamento

### 6.1 Corpo piattaforma

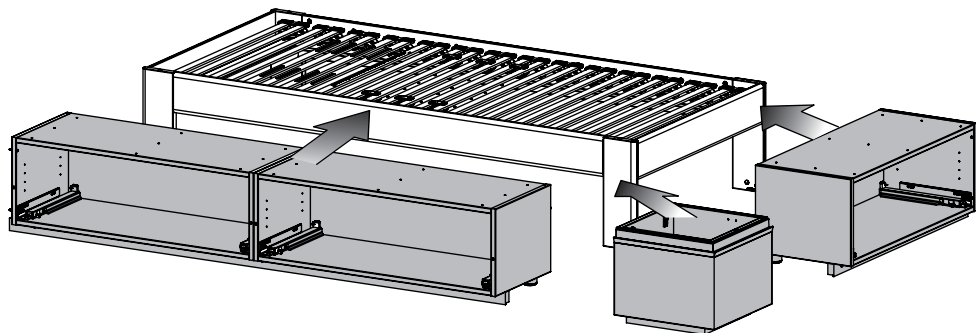

## 6.2 Avvitare il corpo angolato

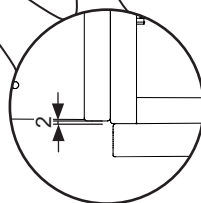
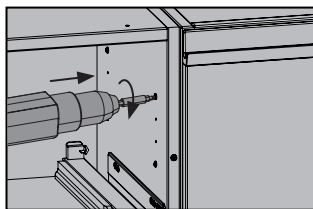
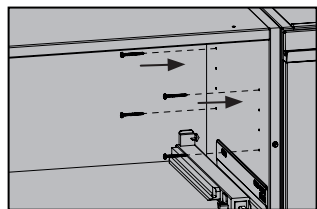
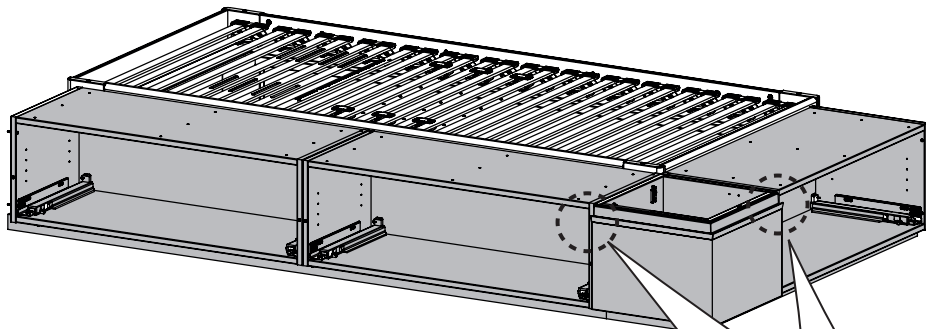

**Tutte le misure sono in millimetri!**

## 6.3 Avvitare i corpi al letto

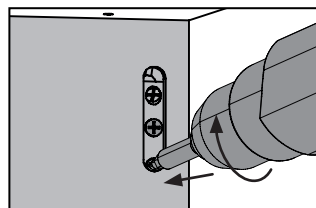
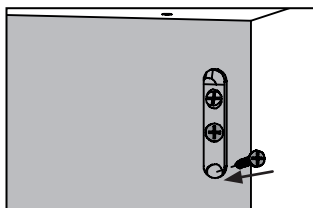
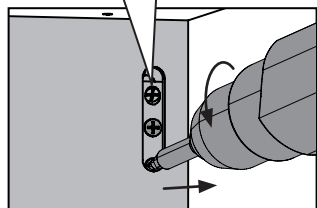
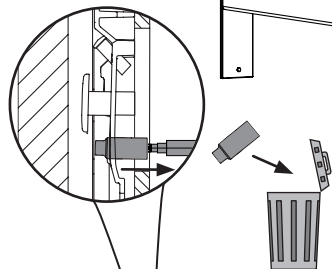
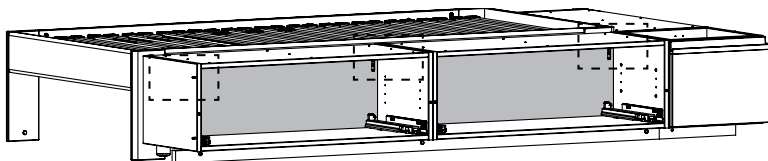
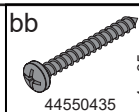

## 7. Antiribaltamento

### 7.1.1 montaggio dispositivo antiribaltamento

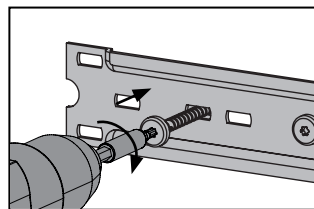
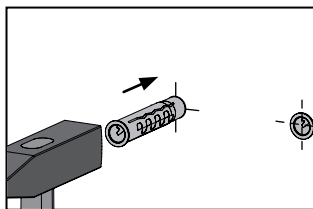
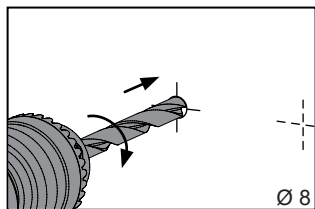
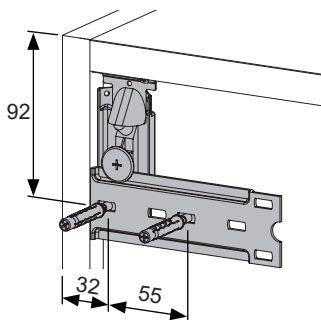
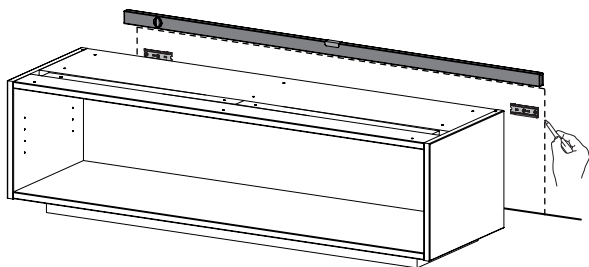
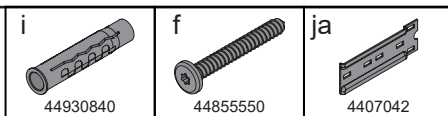

**Tutte le misure sono in millimetri!**

### 7.1.2 Agganciare il corpo

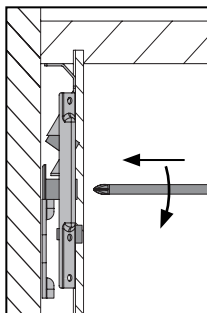
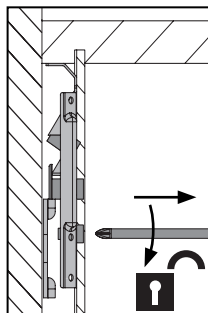
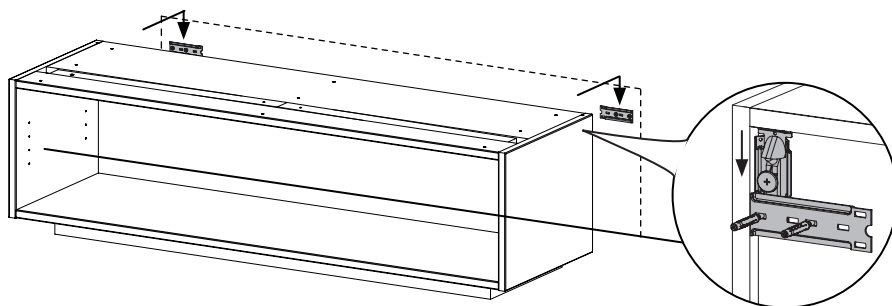

### 7.1.3 Regolazioni del meccanismo

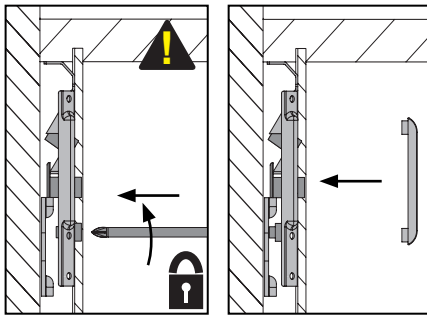
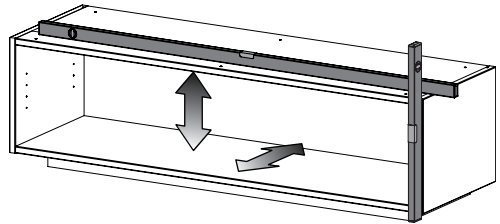
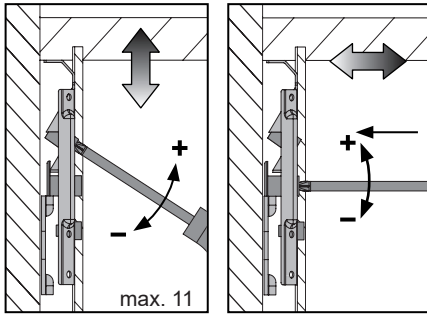
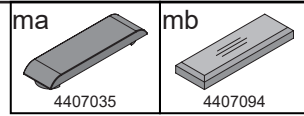

**Tutte le misure sono in millimetri!**

### 7.2 Opzionale: Con corpo con serrandina senza sovrappensile Variante con top

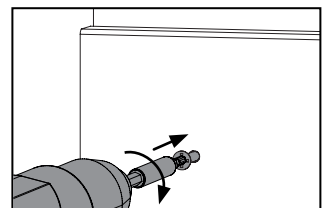
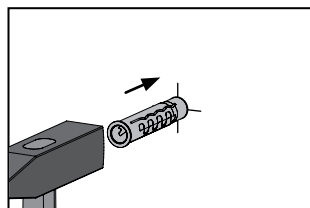
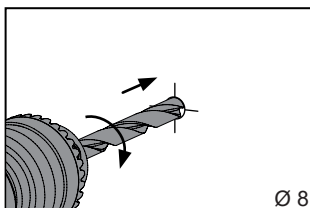
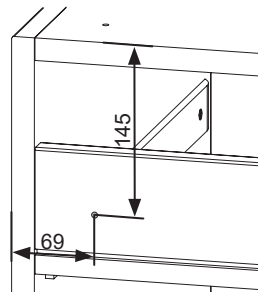
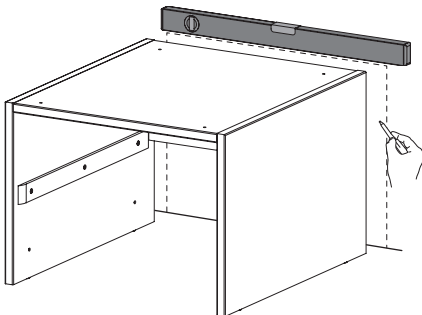
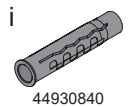

**Tutte le misure sono in millimetri!**

### 7.3 Opzionale: Con cassettone sotto rete

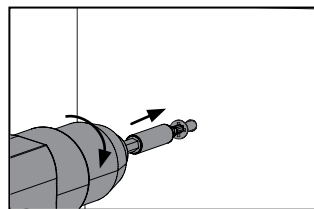
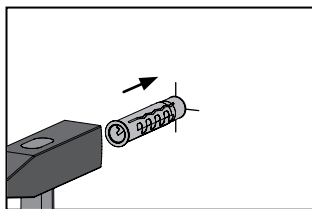
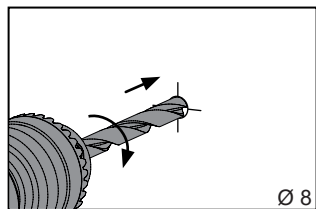
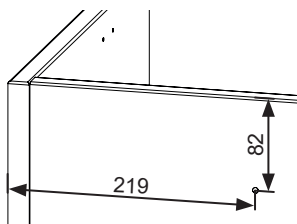
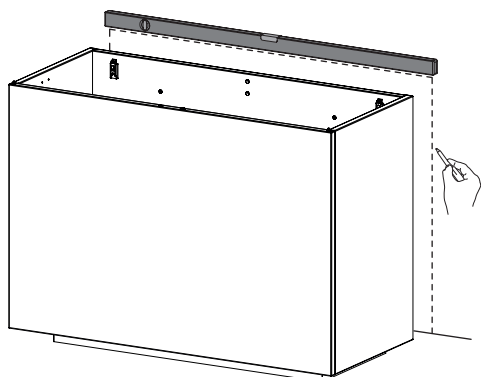
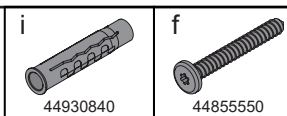

Tutte le misure sono in millimetri!

## 8. Meccanismo di sospensione

### 8.1 montaggio meccanismo di sospensione

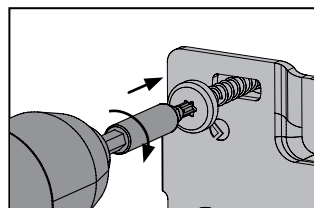
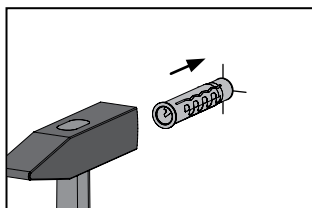
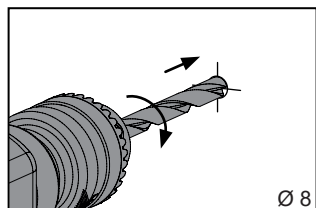
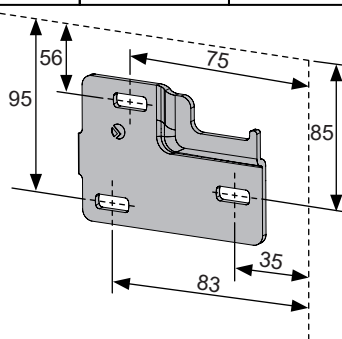
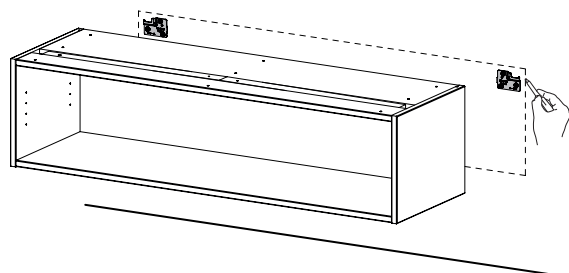
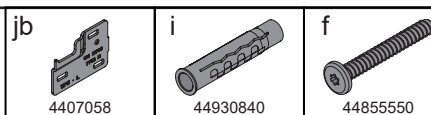

Tutte le misure sono in millimetri!

## 8.2 Appendere e allineare il corpo

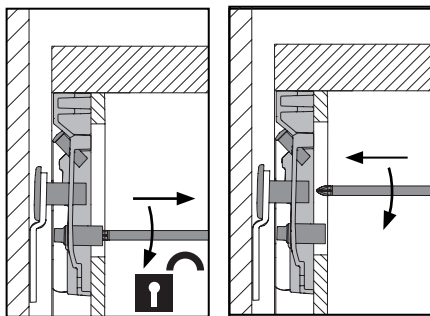
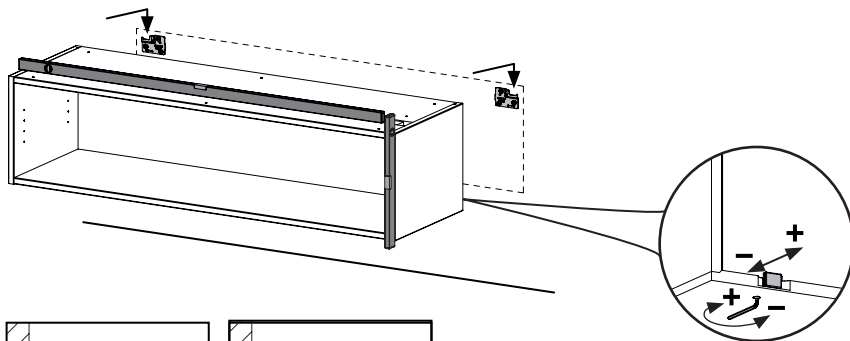

### **HINWEIS**

- Portata max. 120 kg.

## 8.3 Regolazioni del meccanismo

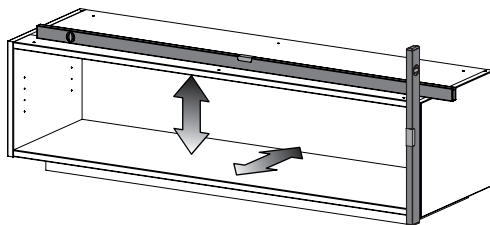
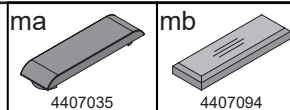
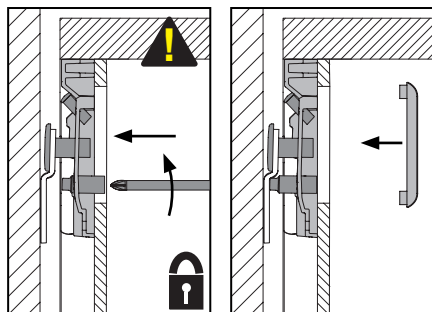
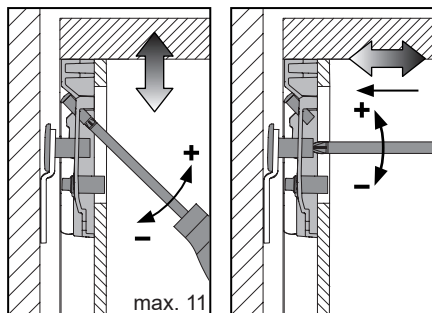

Opzionale:

Copertura in legno solo  
con scaffale aperto

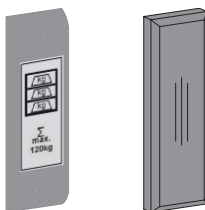

**Tutte le misure sono in millimetri!**

## 9. Montaggio pannelli laterali e top

### 9.1 Fascia laterale

ab

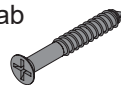

44500435

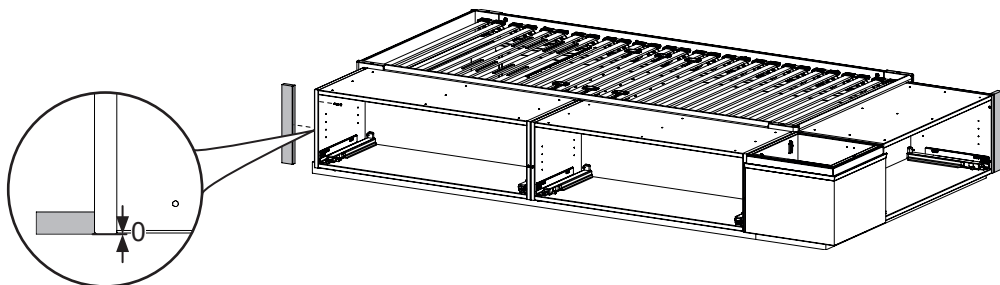

#### **⚠ HINWEIS**

- I pannelli devono essere adattati alla parete.

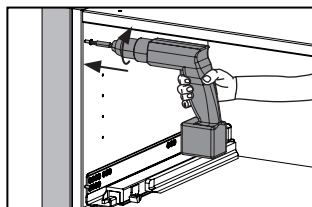
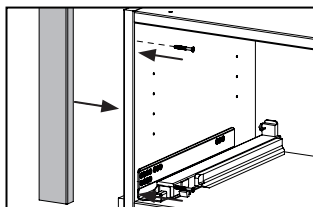

### 9.2 Collegare i piani top



4406061

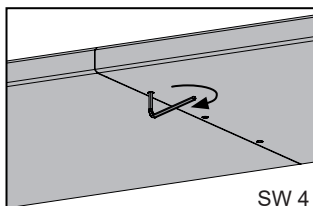
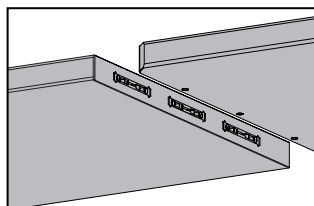
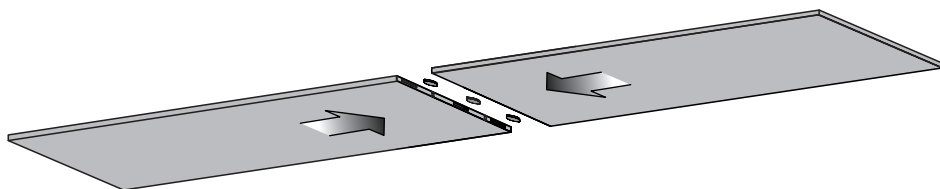

### 9.3 Montare il top

ab

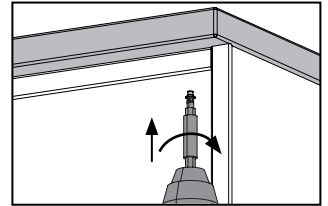
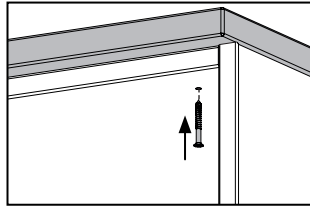
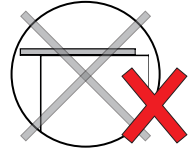
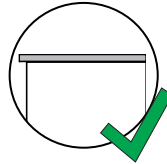
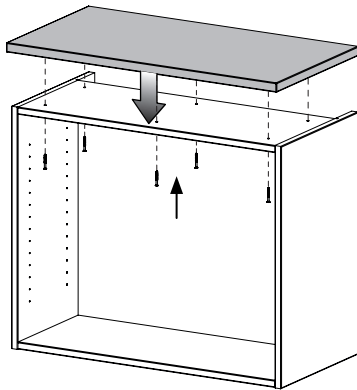
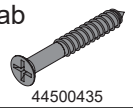

### 10. Montare ruote

ba

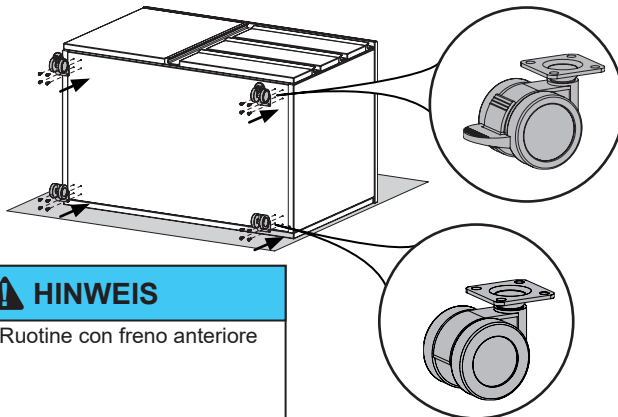

#### **HINWEIS**

- Ruotine con freno anteriore

#### **HINWEIS**

- non appoggiare il piano del tavolo
- La base deve essere pulita e priva di oggetti appuntiti o taglienti.

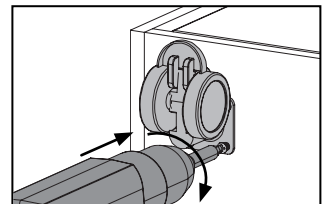
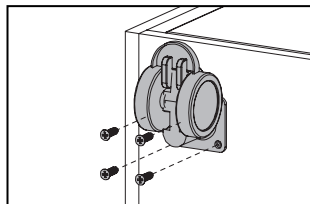
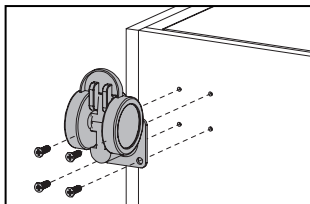



# 11. Componenti frontali

## 11.1 Cassetto

Lade aushängen

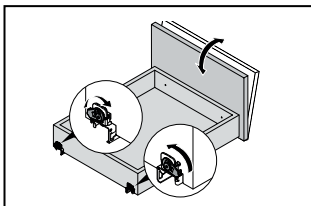
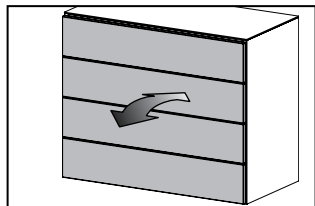
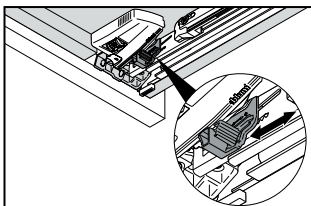
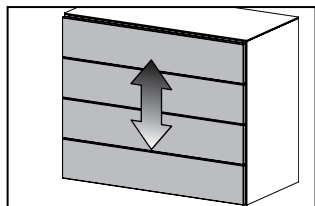
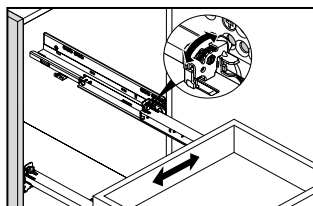
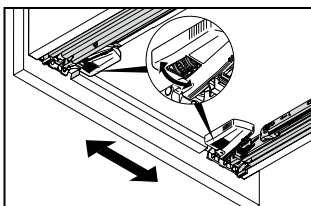
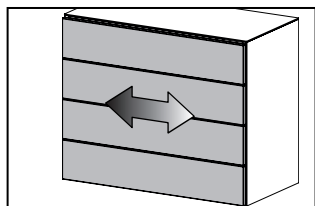
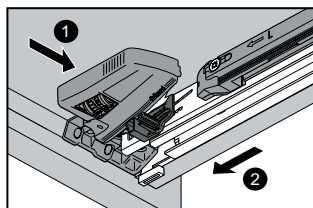
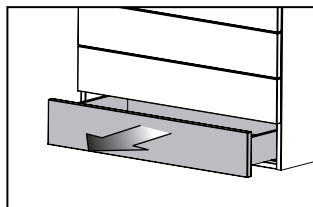
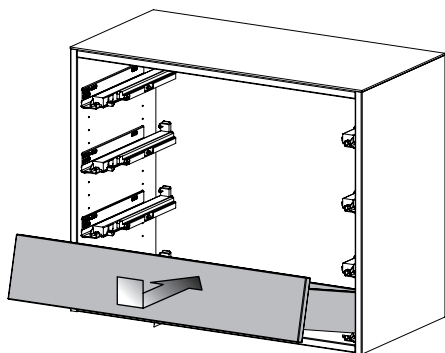

nella variante Tip-On

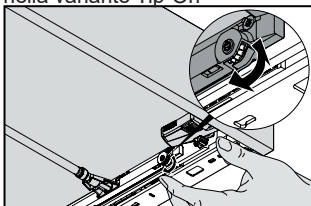
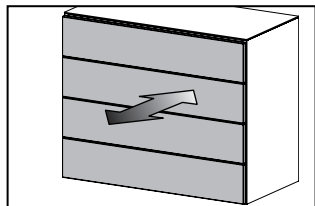

## 11.2 Regolare la profondità della ribaltina

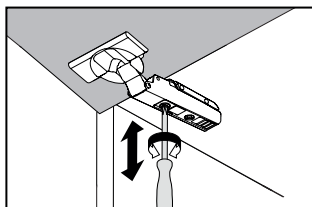
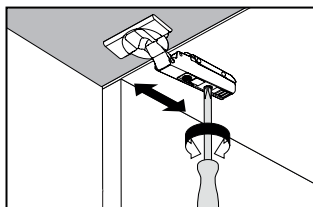
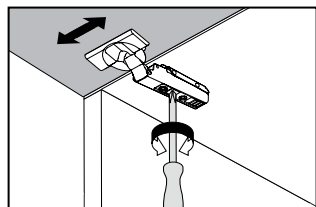
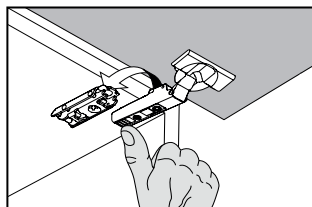
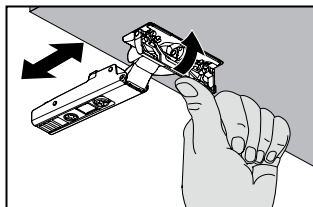
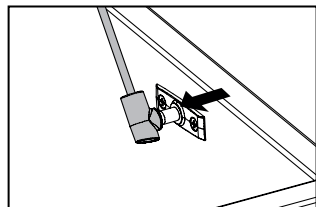
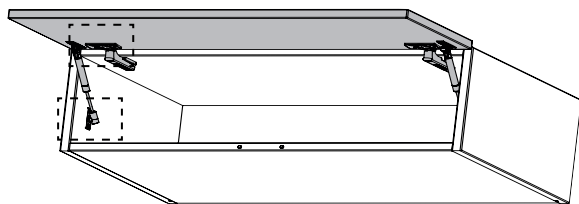

## 11.3 Anta battente

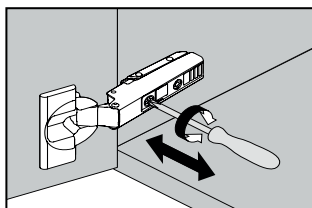
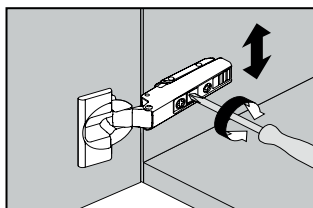
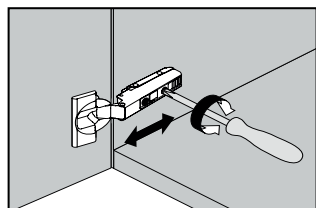
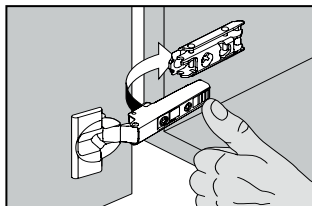
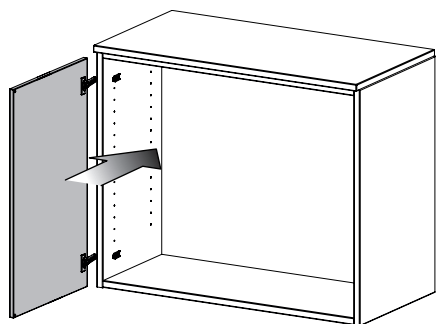

11.4.1 Cassetto su ruote  
Montare ruote

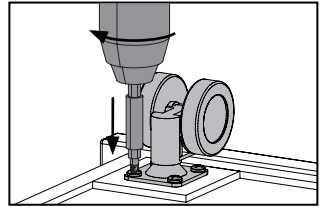
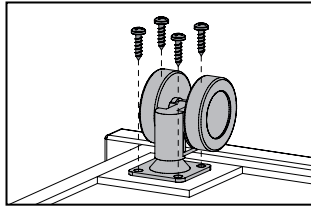
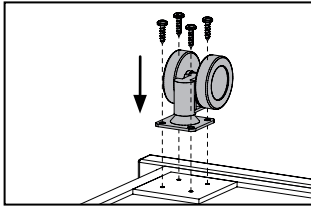
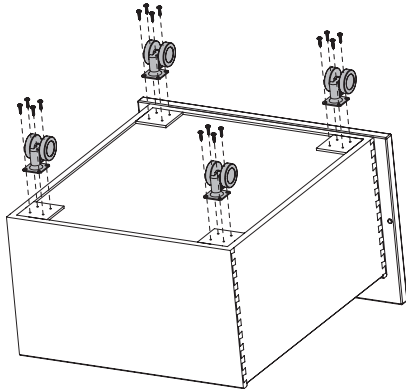
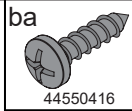

11.4.2 Opzionale: Con elevata distanza frontale  
Inserire il distanziale

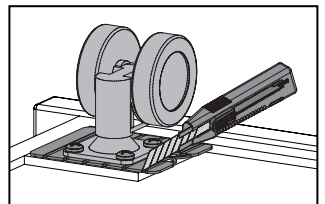
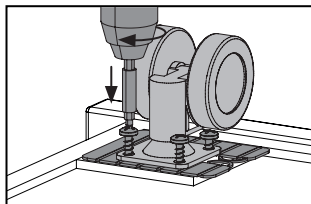
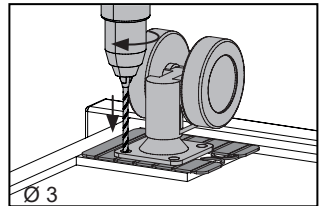
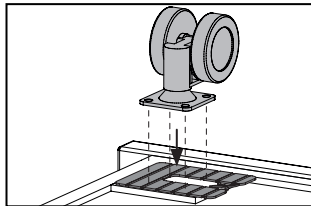
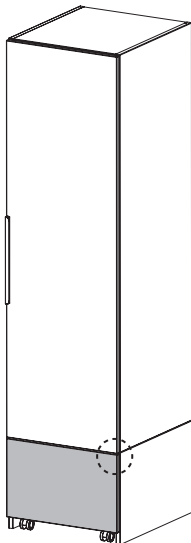
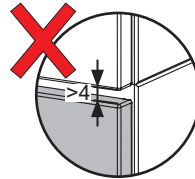
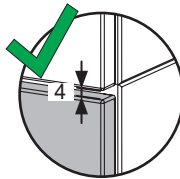
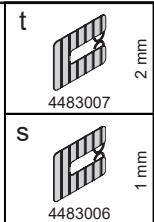

Tutte le misure sono in millimetri!

### 11.4.3 Regolare il cassetto su ruote

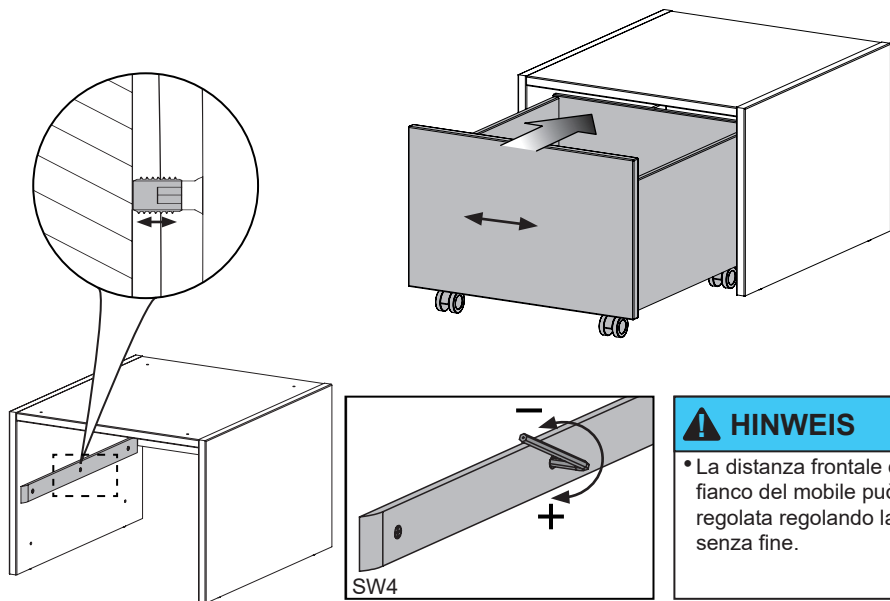

### 11.5 Appendere il pannello a parete

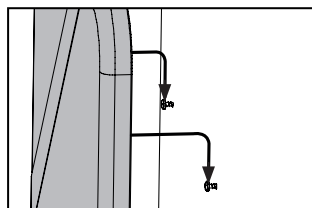
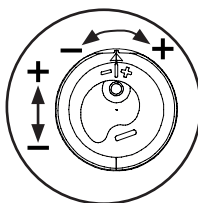
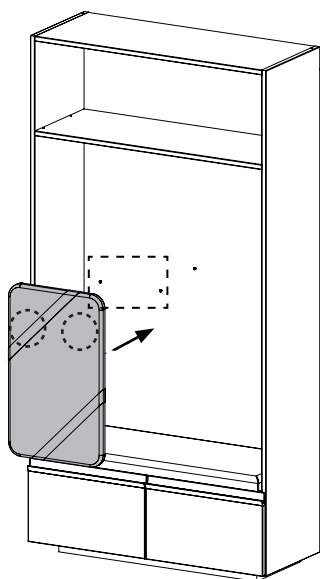

## 11.6 Accensione e spegnimento della luce

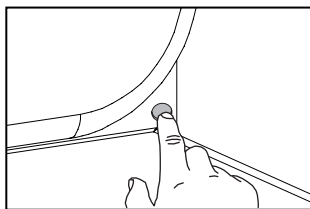
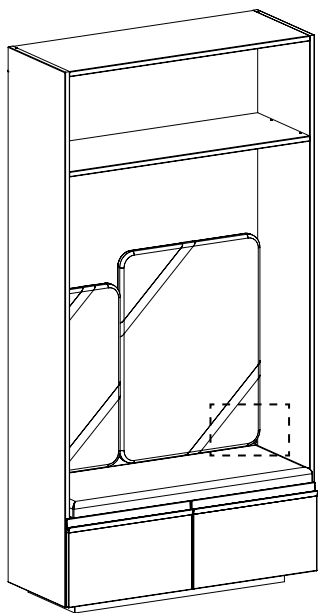

## 12. Divisioni interne

### 12.1 Suddivisione T

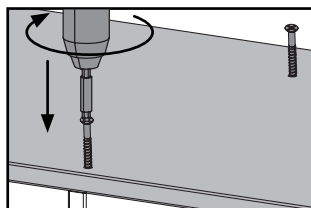
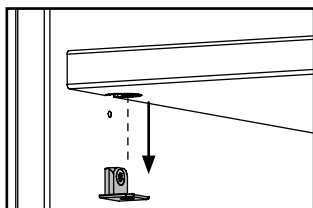
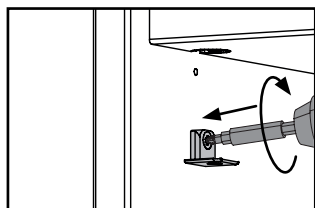
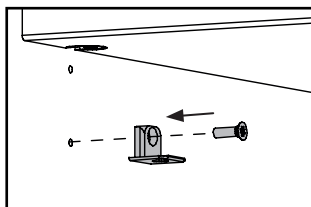
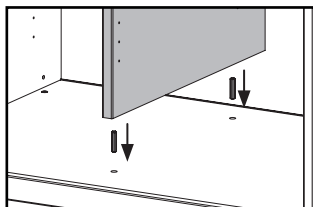
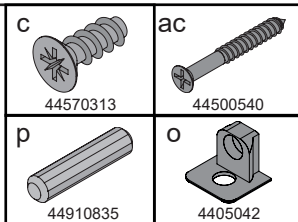
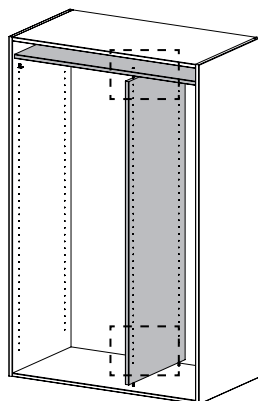

## 12.2 Asta appendiabiti

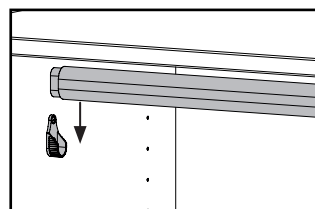
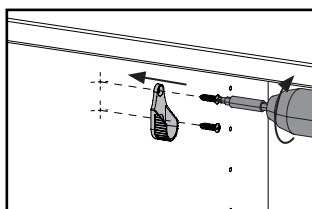
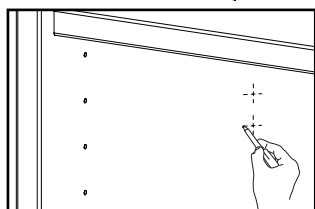
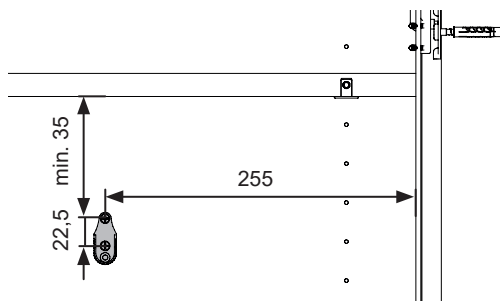
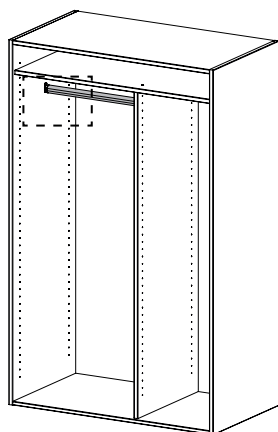
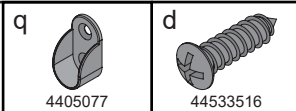

**Tutte le misure sono in millimetri!**

## 12.3 Piano con asta appendiabiti

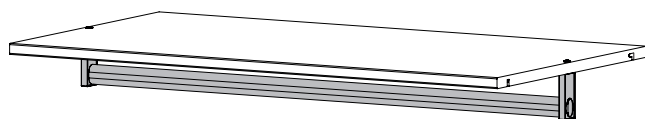
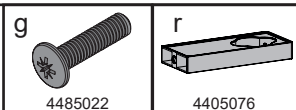

**Hinweis**

- Ripiano con foro previsto per il montaggio dell'asta appendiabiti.
- Le tacche per i supporti dei ripiani devono essere sul lato inferiore.

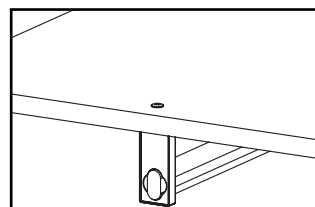
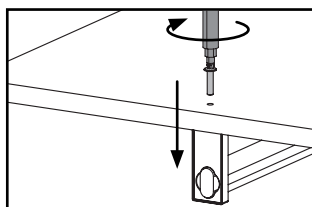
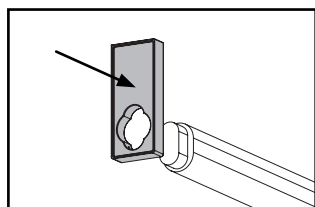

## 12.4 Vano di sicurezza

h

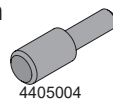

4405004

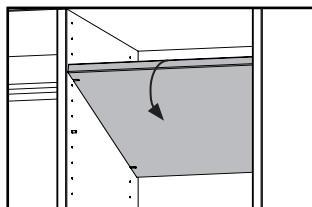
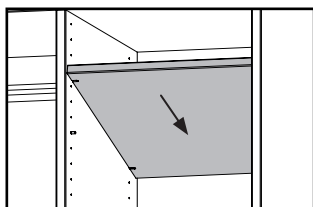
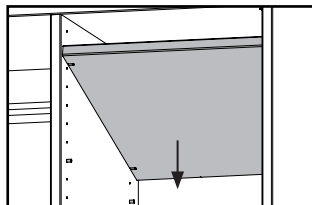
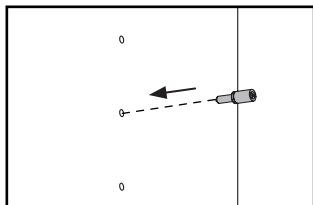
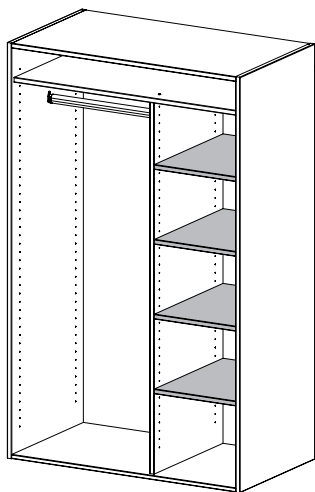

# TEAM 7

## **TEAM 7 Natürlich Wohnen GmbH**

Braunauer Str. 26  
4910 Ried im Innkreis, AUSTRIA

**Montagehotline: +43/7752-977321**

[www.team7-home.com](http://www.team7-home.com)

Con riserva di modifiche, errori, errori di stampa e impaginazione

### Diritto d'autore

La pubblicazione è tutelata da diritto d'autore in tutte le sue componenti. Qualsiasi utilizzo che esuli dagli stretti limiti imposti dalla legge sul diritto d'autore è vietato e perseguibile ai fini di legge senza l'approvazione della ditta TEAM 7 GmbH. Questo vale in particolare per la copia, la riproduzione con microfilm e la memorizzazione ed elaborazione in sistemi elettrici.



# TEAM 7

Dokument für  
die qualifizierte  
Fachkraft!



## Assembly manual

# *Kids*

## Element system

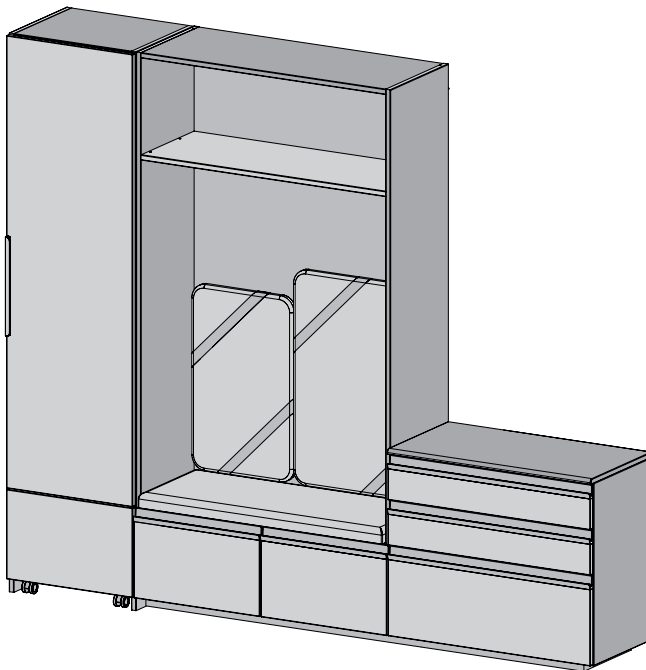

# GB

122022  
TD284010A

Nach der Montage  
zur Aufbewahrung für  
unsere Kunden!

## ! INDOOR CLIMATE

- Ideal indoor climate for human beings, plants and furniture made of natural wood is:

**rel. humidity: 40 to 60% and a  
Room temperature: 18° to 23° Celsius.**

- If these levels are exceeded or not reached for any prolonged period, swelling or shrinkage will occur. This may result in warping, cracking and rough surfaces.

## ! CARE

- Care instructions (care of natural wood, leather, fabric, Stricktex, stone, glass, felt, metal, ceramics and worktops) can be found on the TEAM 7 website.

- Major typical product properties of natural wood furniture from TEAM 7 can also be found in our service and quality certificate on:

<https://www.team7-home.com/at/de/service/service-und-guetepass/>



## ! DOCUMENTATION

- Keep all documents relating to the purchase of your item of furniture in a safe place, also beyond the statutory warranty period of two years.
- If you need replacement or additional parts, please refer to the purchase documentation as this will give you exact information on the product you have purchased and make the process easier.
- If your item of furniture is damaged in transit, it is imperative that you provide photographs of the damaged part while it is still in the original packaging.

## ! IMPORTANT

- The enclosed wall fixing material can only be used for concrete walls, solid brick walls and walls made from vertically perforated bricks\*. Special wall plugs must be used for all other wall types.  
  
\* Work without impact when drilling into vertically perforated bricks!
- The suitability of the substrate must be examined by a qualified person to establish whether the mounting hardware can withstand the applied forces! If necessary, select other mounting hardware that is suitable for the particular nature of the wall.
- TEAM 7 cannot accept any liability for the product if this safety instruction is disregarded!

## ! IMPORTANT

- All electrical work must be carried out by a suitable specialist!
- Never open a power pack. Danger of fatal electric shocks!
- The total of the watt number of spots must not exceed the watt performance of the transformer or the radio unit.
- Cut an opening with a keyhole saw if a cable opening has not been provided.

## Table of contents

<b>1.</b>	<b>Room / planning check</b>	<b>5</b>
<b>2.</b>	<b>Type overview</b>	<b>6-7</b>
<b>3.</b>	<b>Assembling and fitting elements</b>	<b>8-13</b>
<b>4.</b>	<b>Ways of connecting elements</b>	<b>14</b>
4.1	Connect elements	14
4.2	Aufsatzkorpus	14
<b>5.</b>	<b>Plinth installation</b>	<b>15-17</b>
5.1	Recessed plinth	15
5.2	Installing plinth where place is limited	15-16
5.3	Alignment	16
5.4	Tambour-door element: Height adjuster	17
<b>6.</b>	<b>Placement</b>	<b>17-18</b>
<b>7.</b>	<b>Anti-tilt guard</b>	<b>19-21</b>
7.1	Assembly of anti-tilt guard	19-20
7.2	Anti-tilt guard for tambour-door element	20
7.3	Anti-tilt guard for bed chest	21
<b>8.</b>	<b>Assembly of wall-mount fitting</b>	<b>21-22</b>
7.1	Assembly of wall-mount fitting	21
7.2	Hooking in and aligning element	22
7.3	Adjustment of fittings	22
<b>9.</b>	<b>Mounting side panels and top boards</b>	<b>23-24</b>
9.1	Side panel	23
9.2	Connect top boards	23
9.3	Fit top panel	24
<b>10.</b>	<b>Install castors</b>	<b>24</b>
<b>11.</b>	<b>Front components</b>	<b>25-28</b>
11.1	Drawer	25
11.2	Flap door	26
11.3	Hinged door	26
11.4	Castor-mounted drawer	27-28
11.5	Wall panel	28
11.6	Switching light ON and OFF	29
<b>12.</b>	<b>Interior partitioning</b>	<b>29-31</b>
12.1	T-partitioning	29
12.2	Clothes rail	30
12.3	Shelf with clothes rod	30
12.4	Theft-proof compartment	31

## Tools

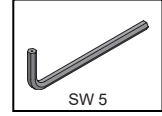
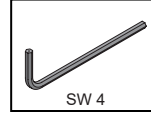
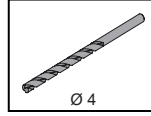
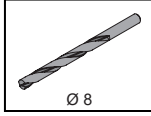
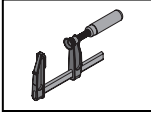
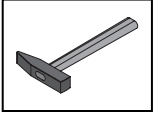
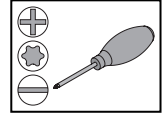
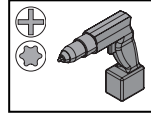
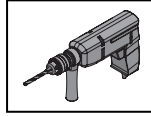
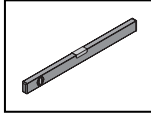
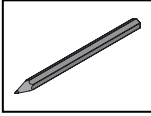

## Fittings

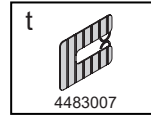
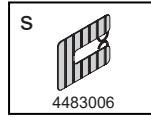
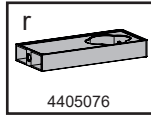
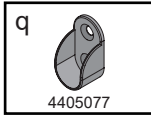
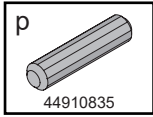
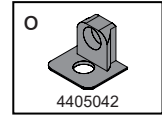
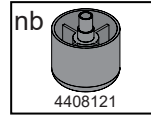
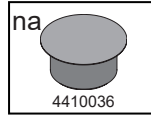
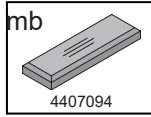
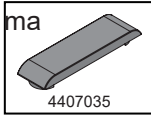
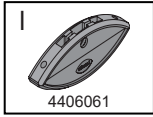
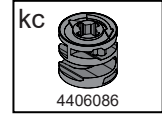
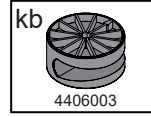
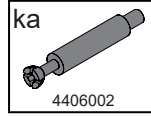
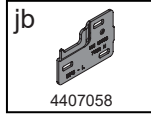
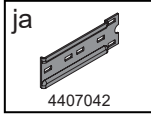
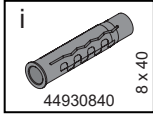
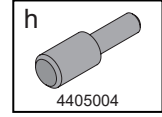
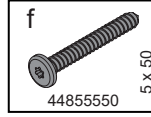
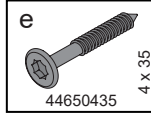
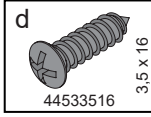
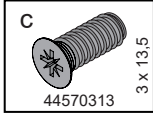
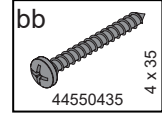
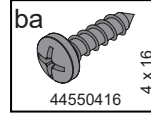
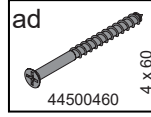
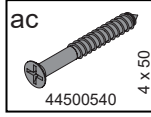
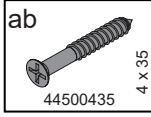
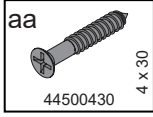

# 1. Room and planning check

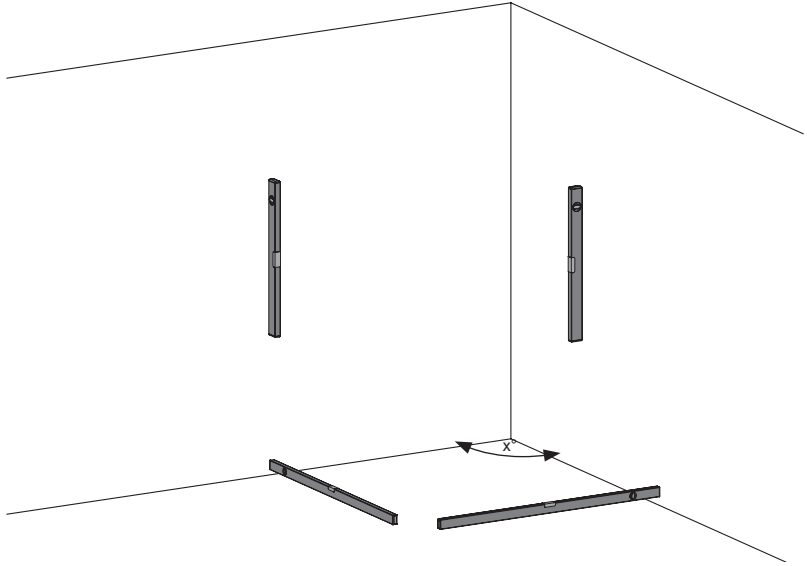

Notes

.....

.....

.....

.....

.....

.....

## 2. Type overview

### Basic element

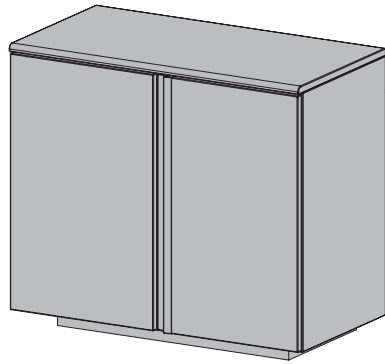
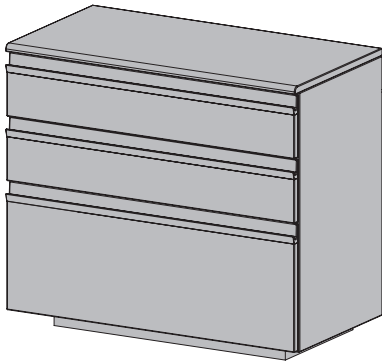

### Platform element

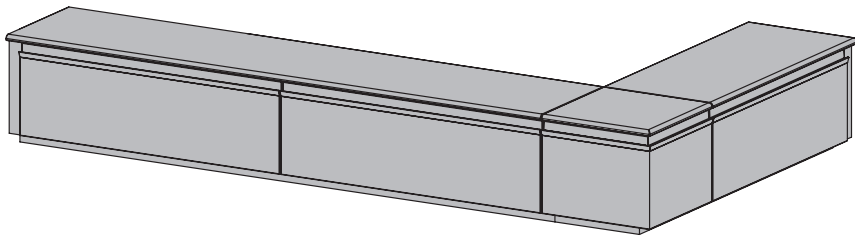

### Bed chest

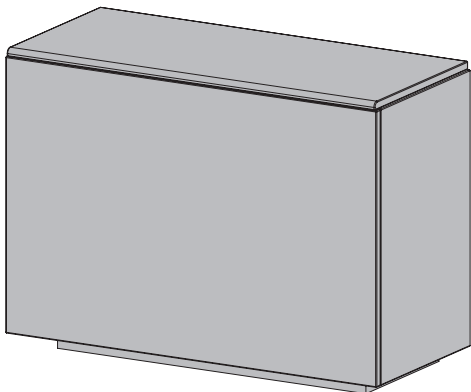

### Alcove seating

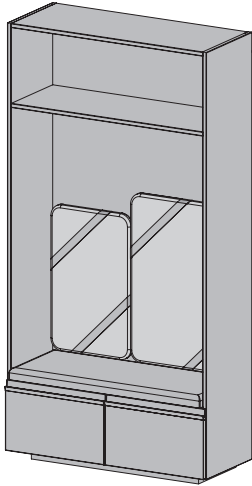

### Tambour-door element

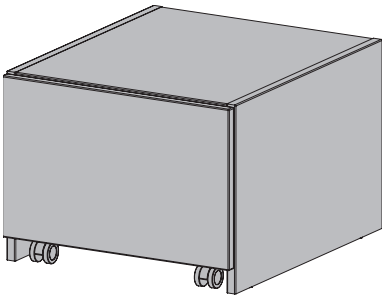

### Mobile pedestal

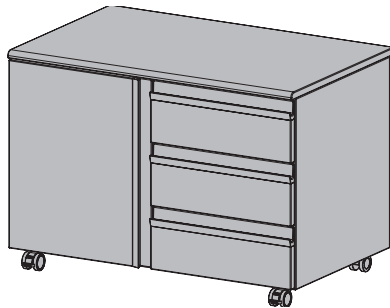
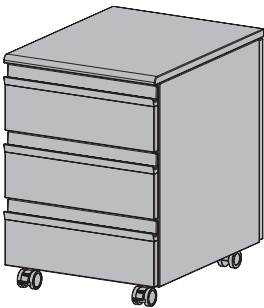

### 3. Optional: Assembling and fitting elements

#### 3.1 Element disassembled

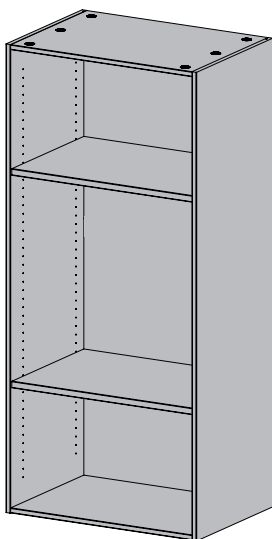

#### 3.2 Screwing in bolts

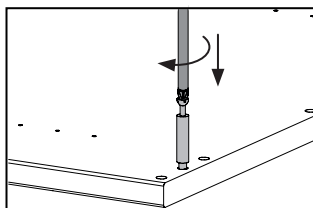
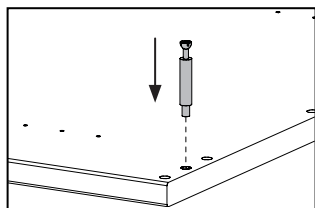
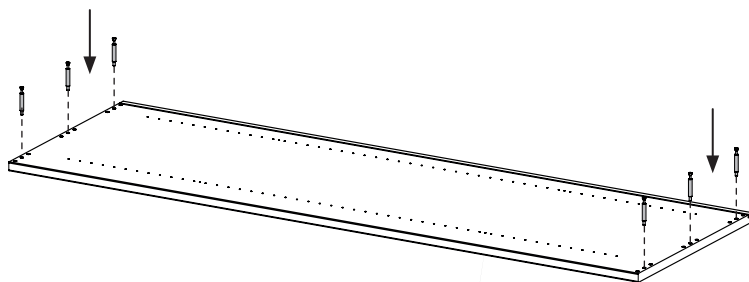
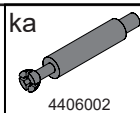



### 3.3 Press in housing

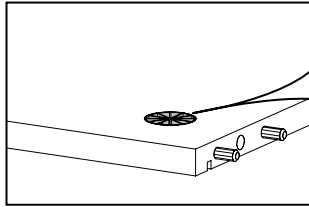
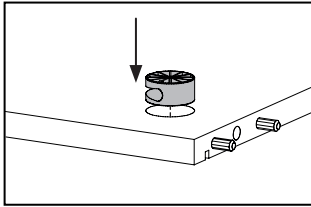
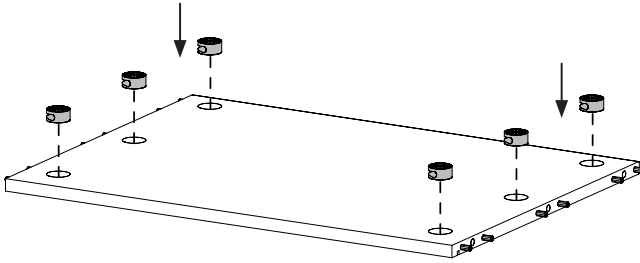
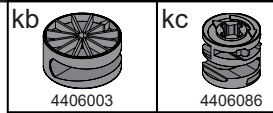

### 3.4 Attaching top and bottom panel

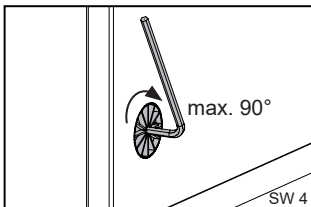
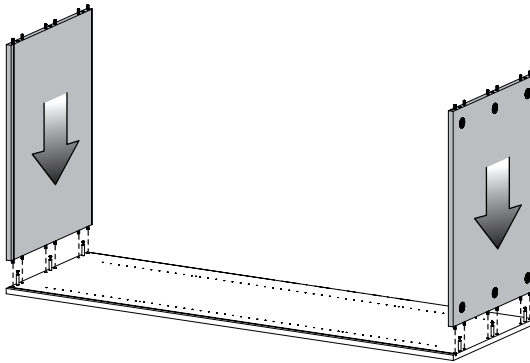

### 3.5 Optional: For alcove seating

#### 3.5.1 Unscrewing upholstered seat from intermediate panel

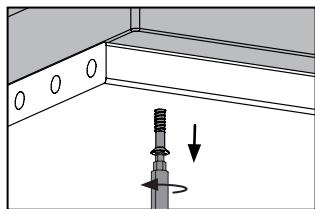
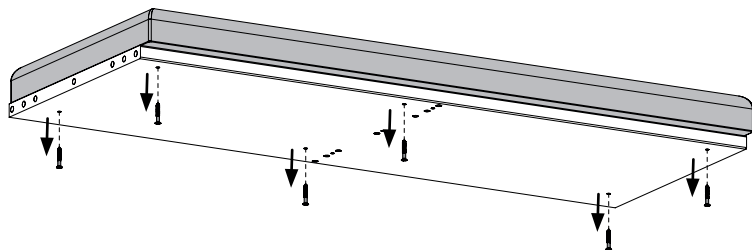

#### 3.5.2 Fitting intermediate shelf

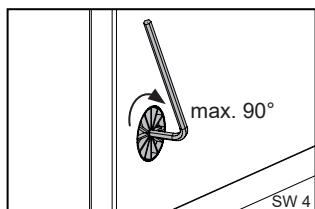
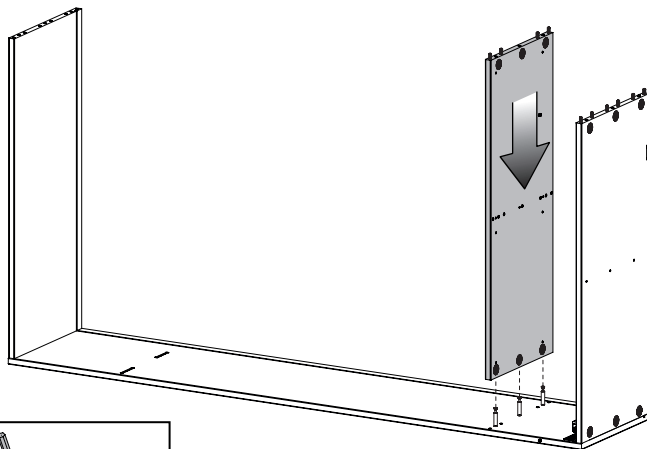

### 3.6 Insert back wall

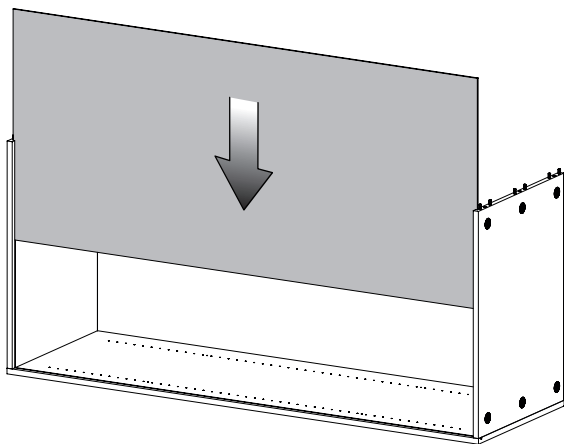

### 3.7 Securing outer side

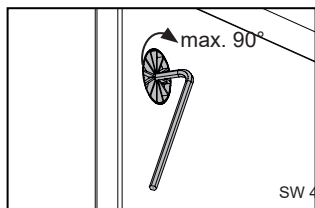
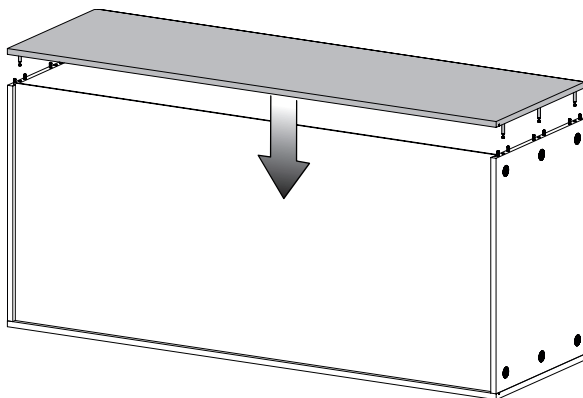

### 3.8.1 Optional: For alcove seating

Screw-mounting middle panel to bottom shelf and intermediate shelf

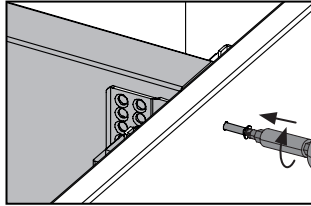
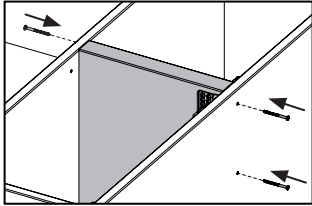
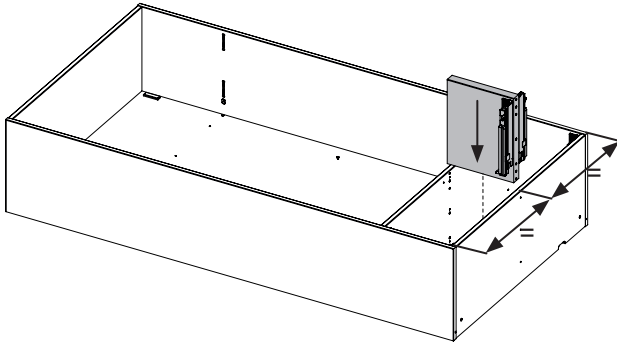

### 3.8.2 Screwing upholstered seat back to intermediate panel

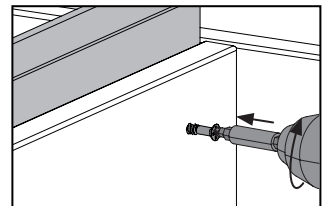
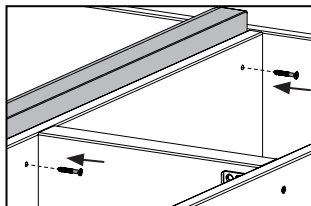
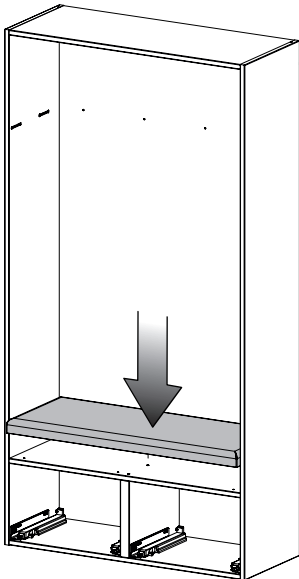

### 3.8.3 Screw back board in place

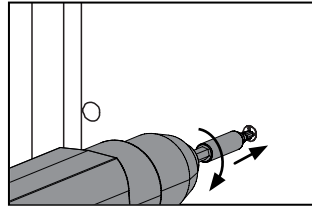
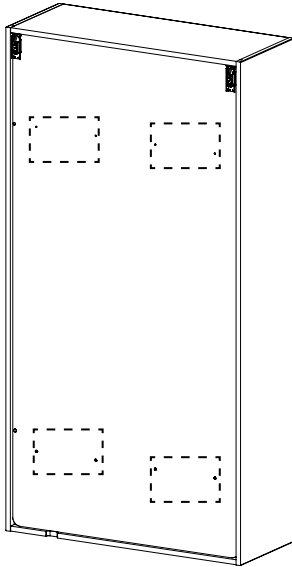

### 3.8.4 Fitting intermediate shelf

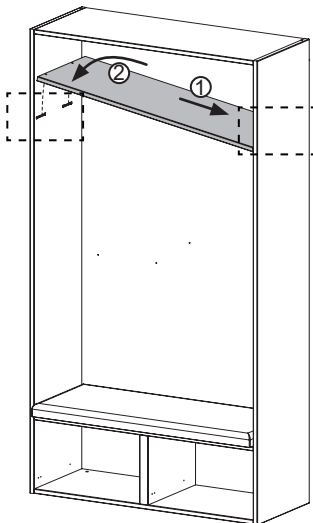

#### HINWEIS

- Always fit shelf on right first so as not to get the cable caught.

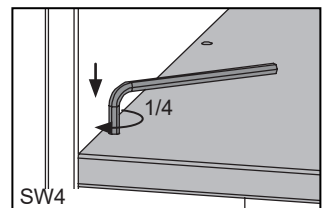
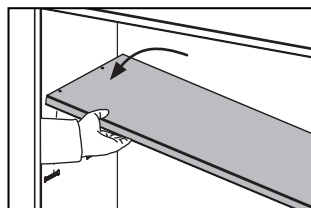

## 4. Ways of connecting elements

### 4.1 Connect elements

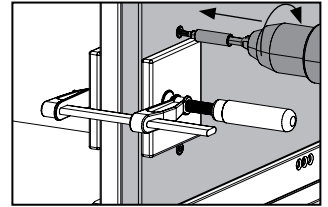
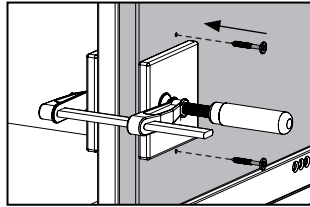
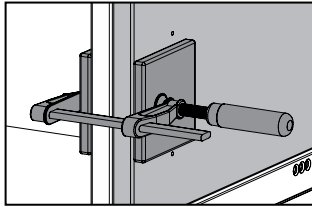
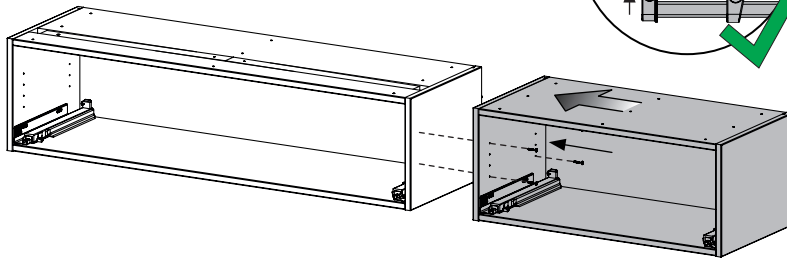

### 4.2 Optional: For tambour-door element Screwing top-mounted element in place

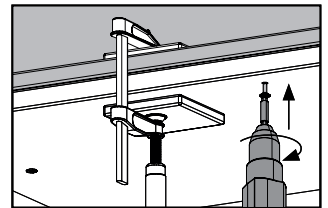
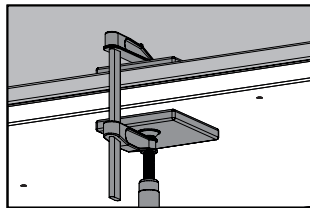
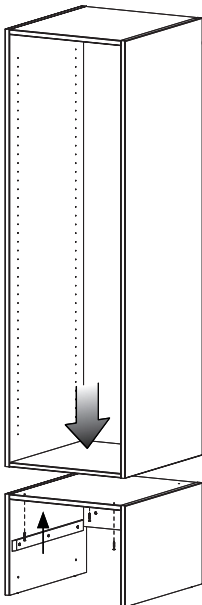
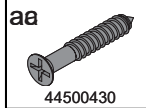

#### **! HINWEIS**

- Carefully screw in screws.
- Aligning for flush fit at sides and front.

#### **! HINWEIS**

- By way of option, also available with top board only. For fitting, see point 9.
- Anti-tilt guard for top-mounted element. For fitting, see point 7.

## 5. Plinth variants

### 5.1 Back-set plinth frame

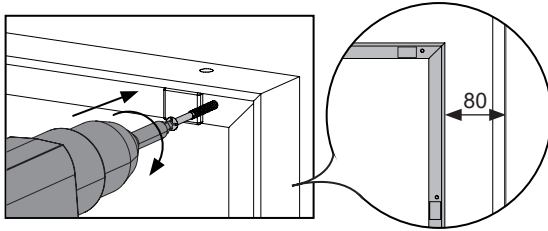
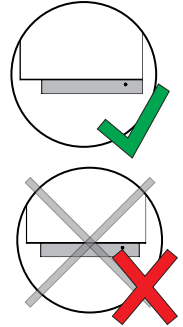
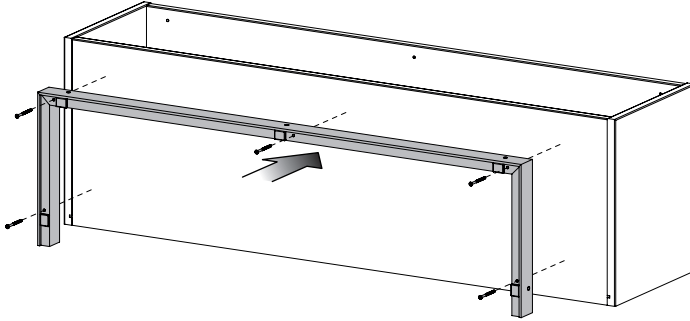
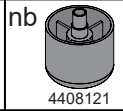
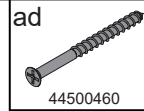

Optional: Where elements are butt-jointed

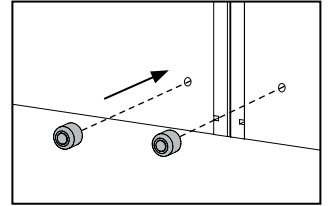

Alle Maße in Millimeter

### 5.2 Installing plinth where place is a problem

#### 5.2.1 Placing element

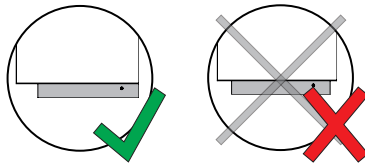
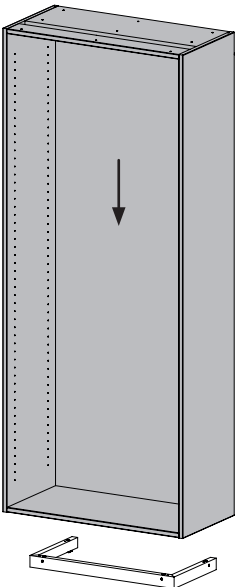
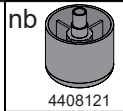

Optional: Where elements are butt-jointed

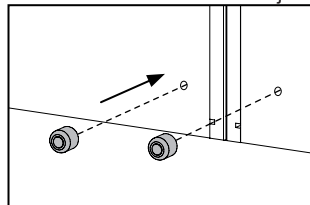

#### **HINWEIS**

- Screws will be visible later on. Only fit plinth from the inside if absolutely necessary!

### 5.2.2 Screwing element to plinth

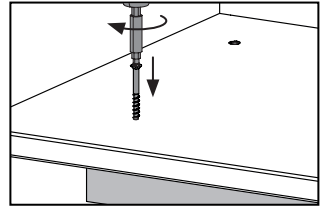
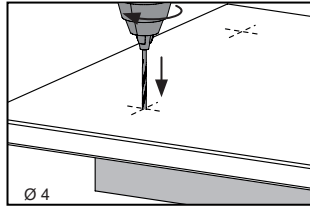
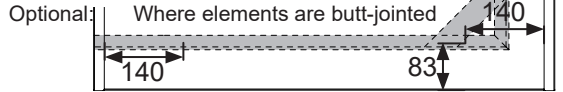
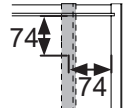
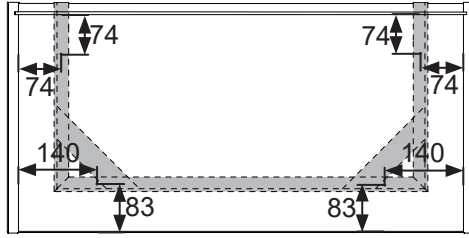
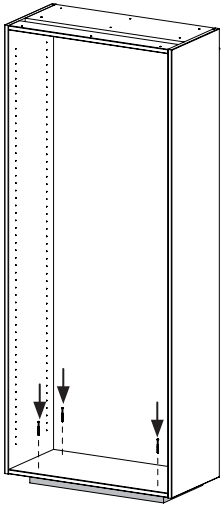
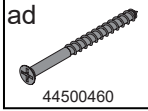

All dimensions in millimeters

### 5.3 Alignment

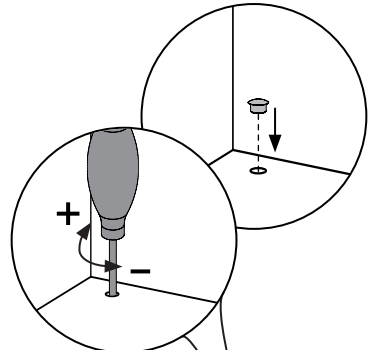
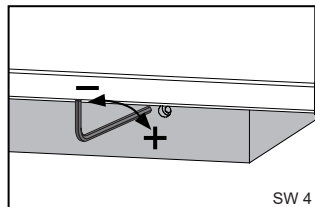
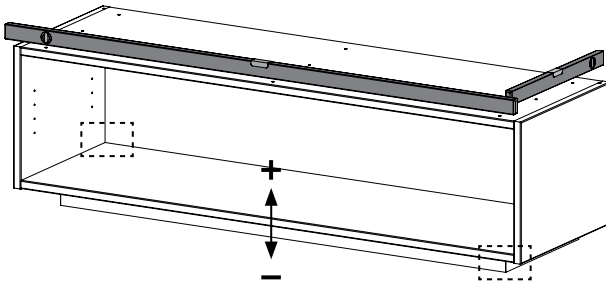
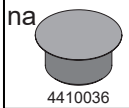

Optional:

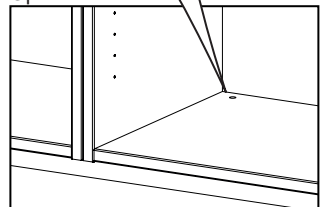



5.4 Optional: For tambour-door element  
Aligning element by means of height adjusters

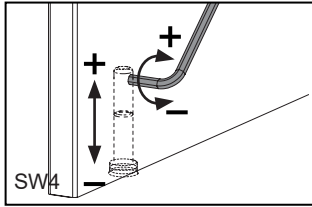
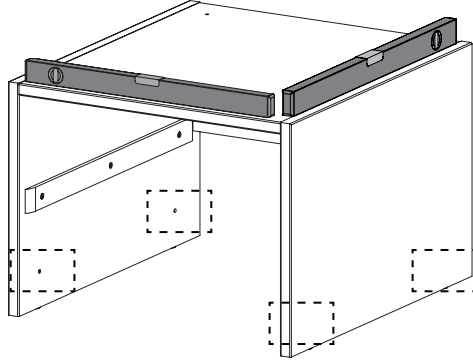

**6. Placement**

6.1 Platform element

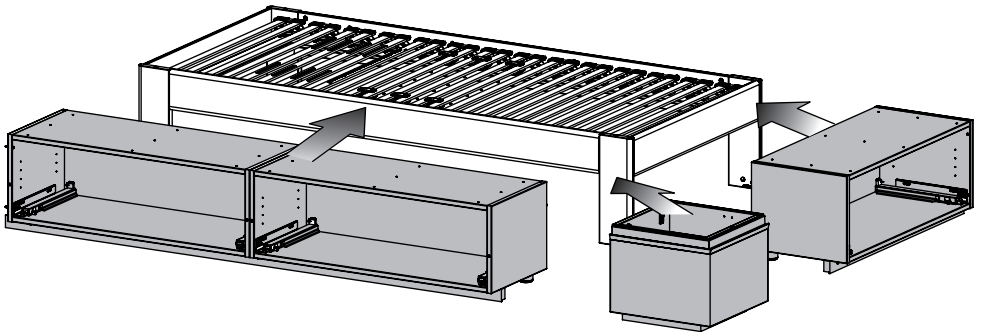

## 6.2 Screw-mounting corner element

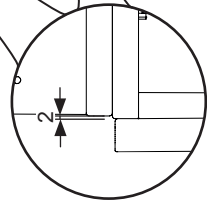
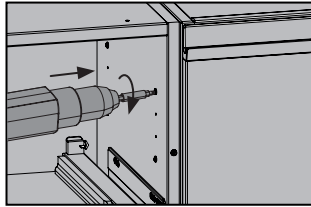
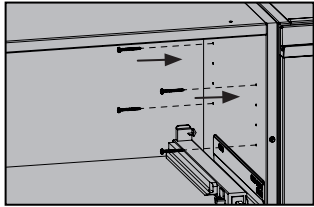
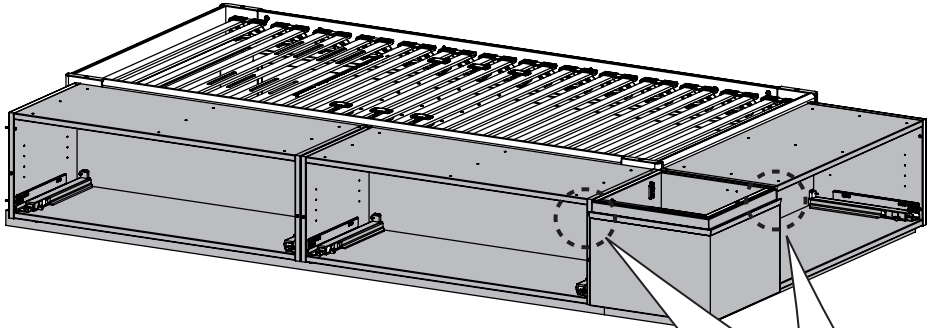

All measurements in millimetres!

## 6.3 Screw-mounting elements to bed

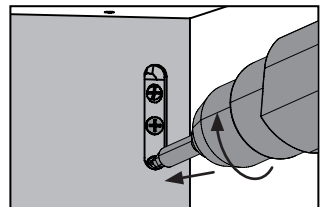
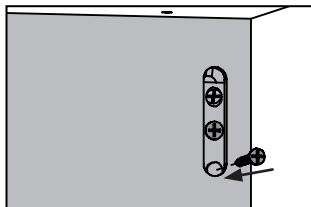
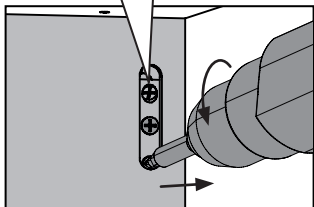
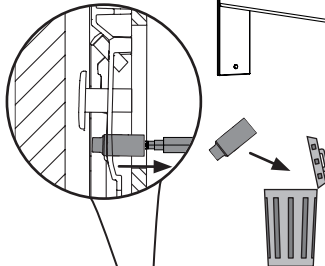
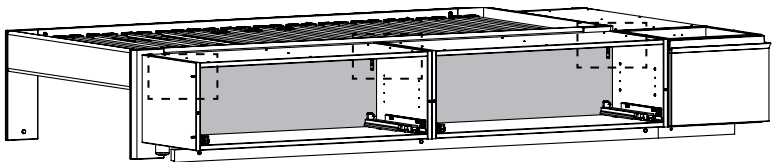

## 7. Anti-tilt guard

### 7.1.1 Assembly of anti-tilt guard

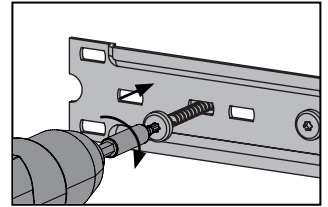
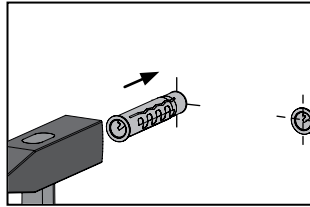
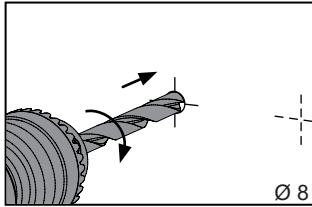
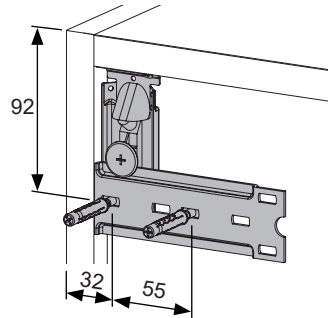
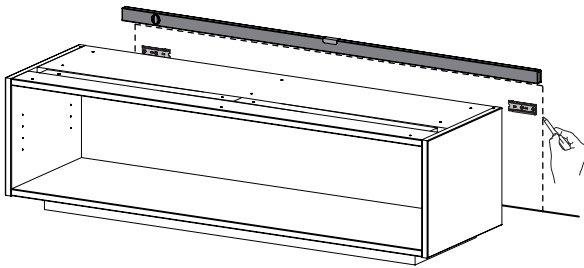
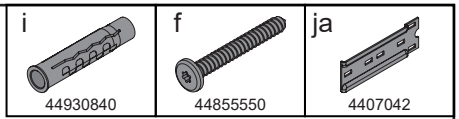

**All measurements in millimetres!**

### 7.1.2 Hook in element

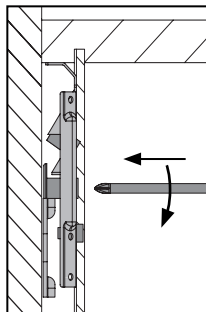
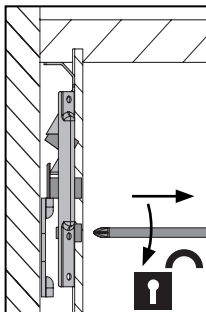
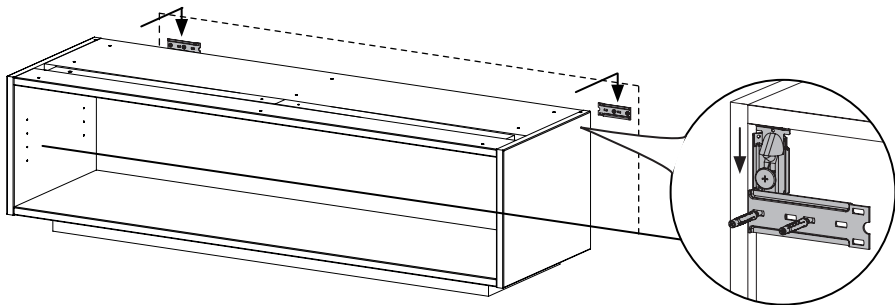

### 7.1.3 Adjustment of fittings

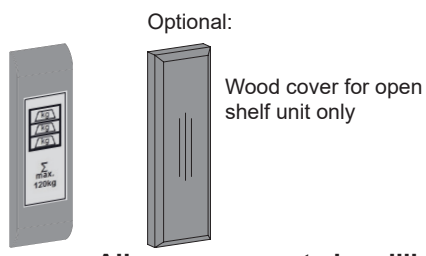
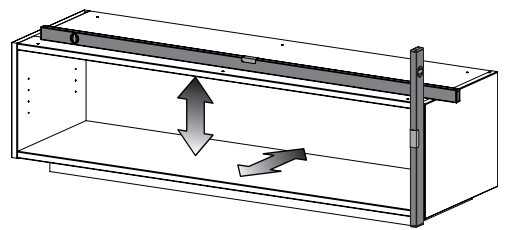
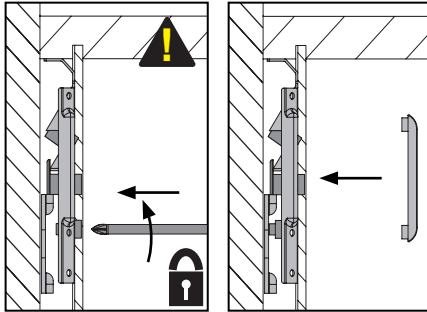
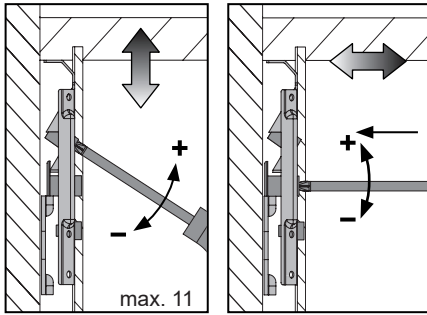
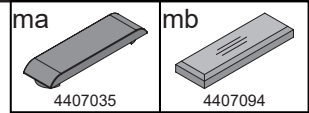

**All measurements in millimetres!**

### 7.2 Optional: For tambour-door element without top-mounted element Option with top board

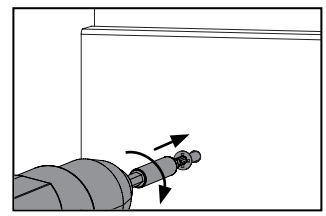
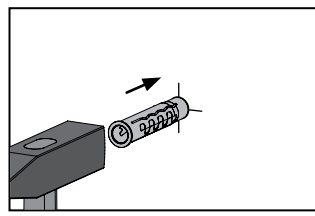
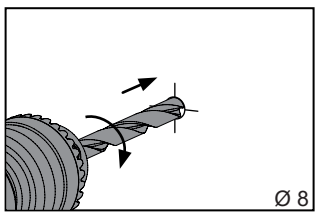
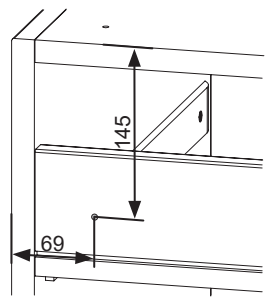
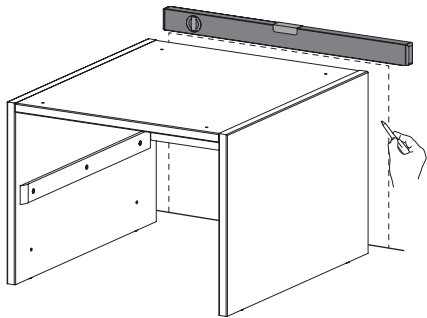
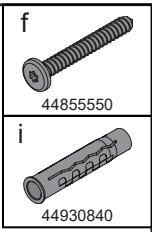

**All measurements in millimetres!**

### 7.3 Optional: For bed chest

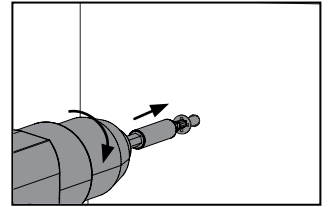
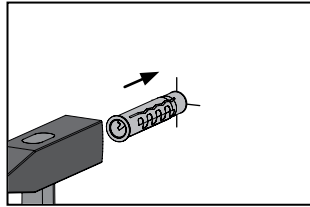
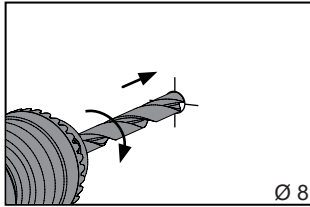
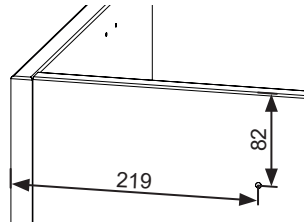
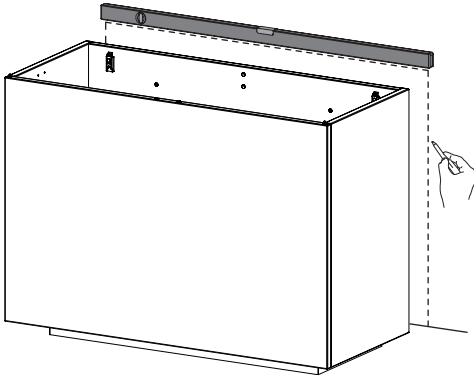
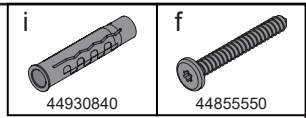

All measurements in millimetres!

## 8. Wall-mount fitting

### 8.1 Assembly of wall-mount fitting

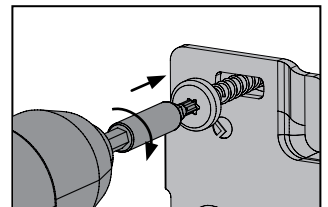
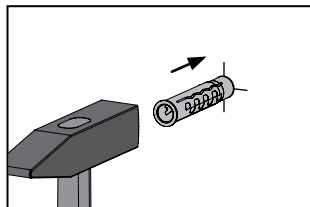
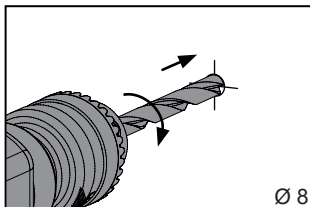
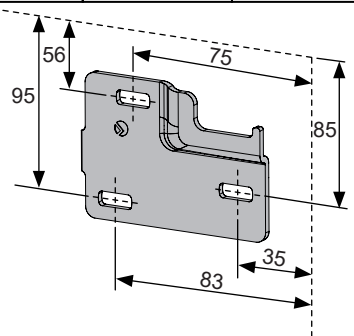
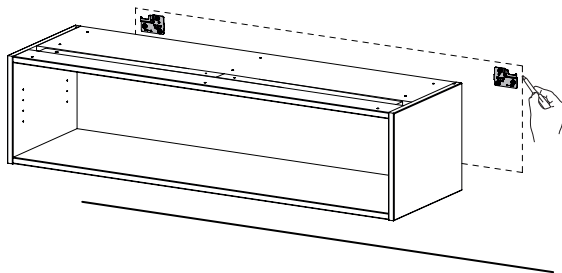
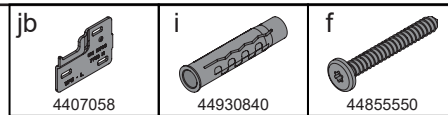

All measurements in millimetres!

## 8.2 hooking in and aligning element

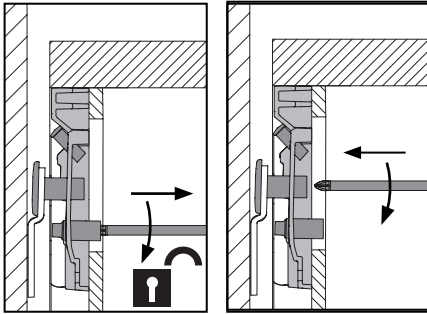
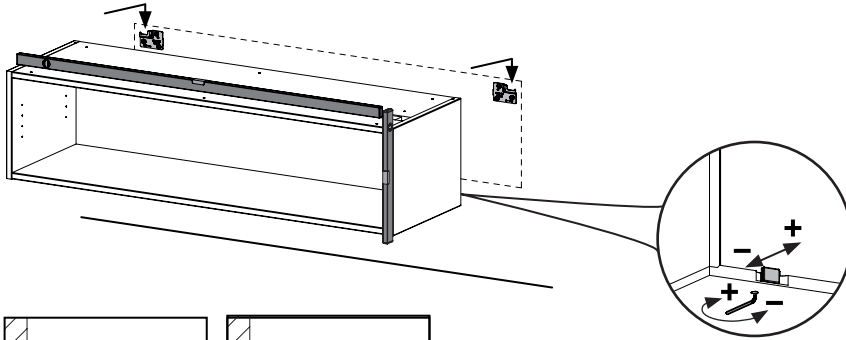

### **HINWEIS**

- Max. load-bearing capacity 120 kg.

## 8.3 Adjustment of fittings

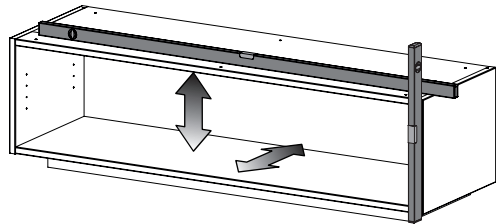
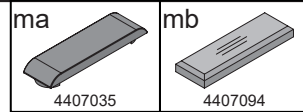
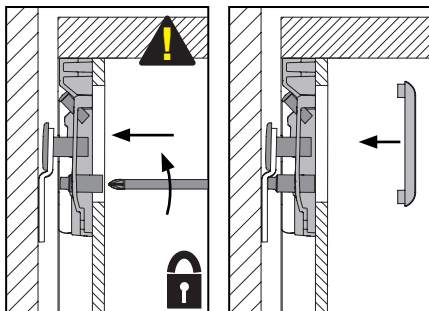
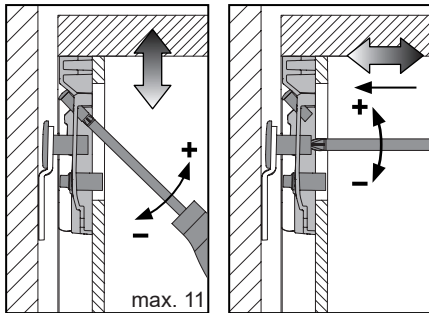

Optional:  
Wood cover for open  
shelf unit only

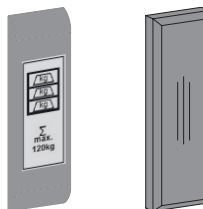

**All measurements in millimetres!**

## 9. Mounting side panels and top boards

### 9.1 Side panel

ab

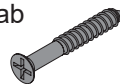

44500435

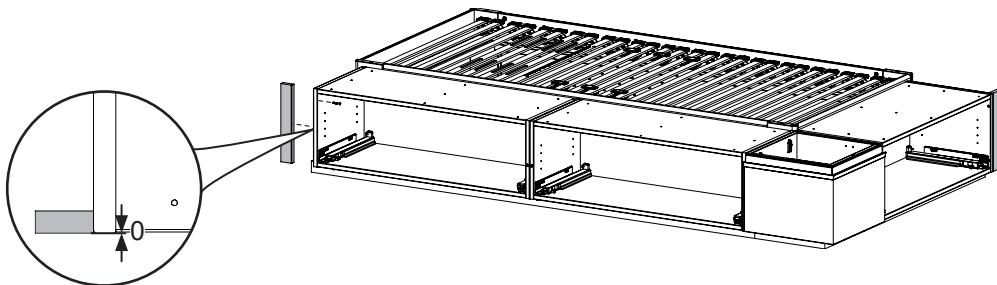

#### **! HINWEIS**

- Panels must be made to fit the wall.

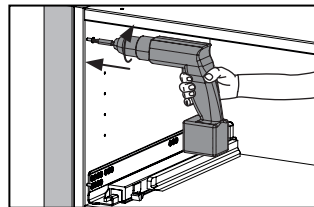
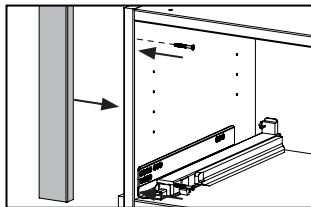

### 9.2 Connect top boards



4406061

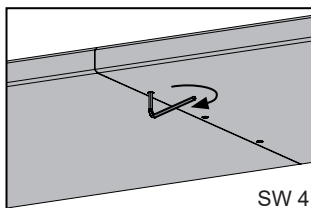
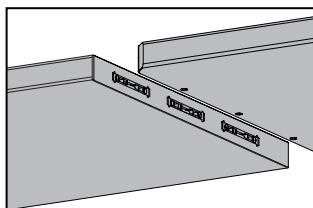
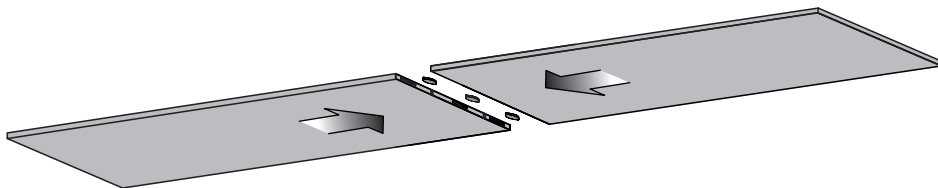

### 9.3 Fit top panel

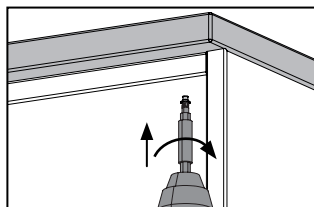
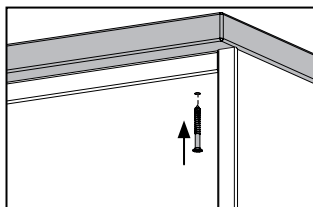
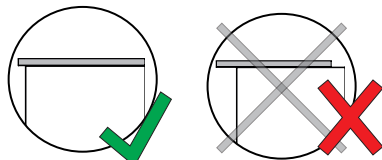
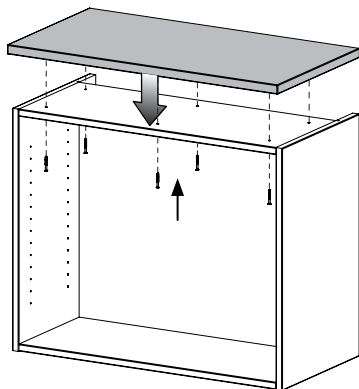
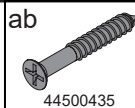

### 10. Install castors

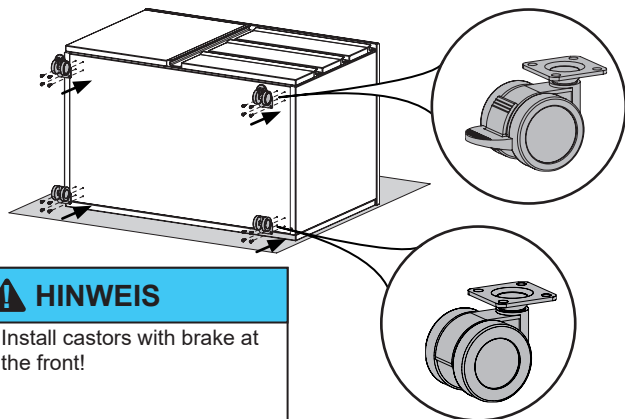

**HINWEIS**

- Install castors with brake at the front!

**HINWEIS**

- assemble on a mat or
- The base surface must be clean and free from pointed or sharp-edged objects.

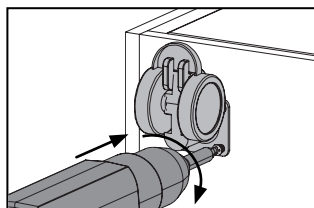
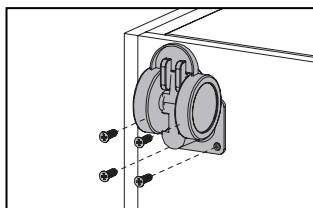
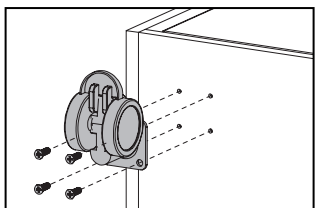



# 11. Front components

## 11.1 Drawer

Lade aushängen

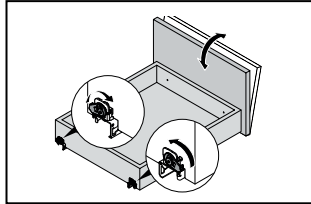
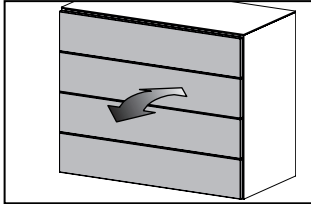
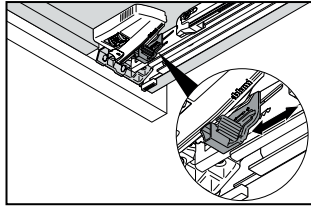
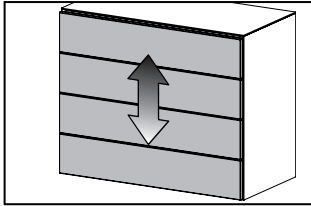
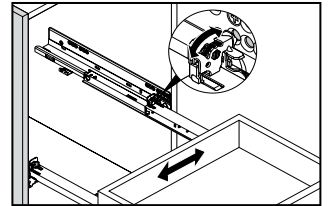
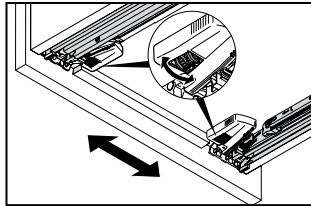
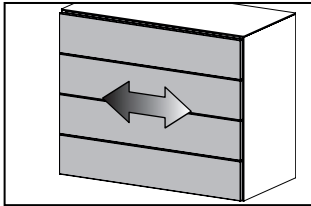
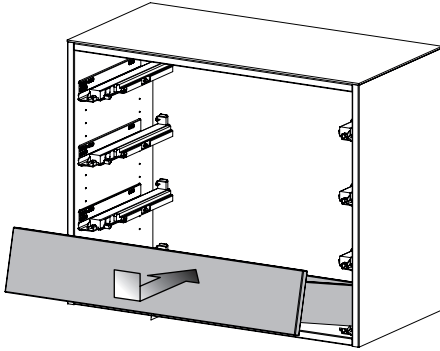
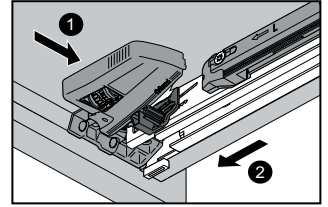
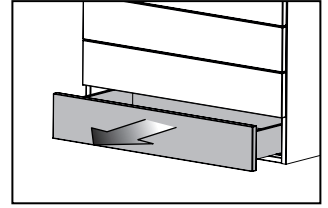

Variante Tip-On

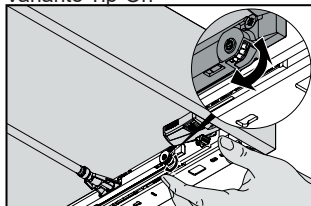
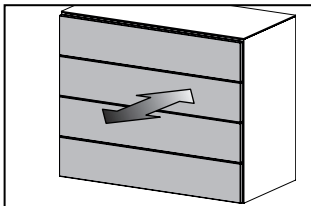

## 11.2 Adjusting flap-door position

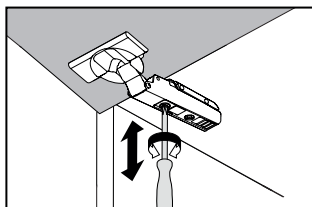
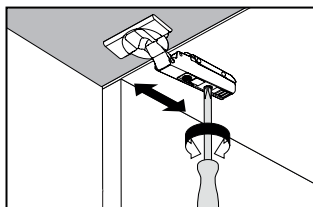
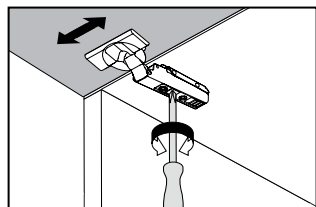
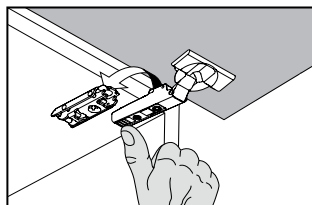
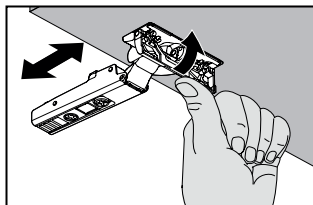
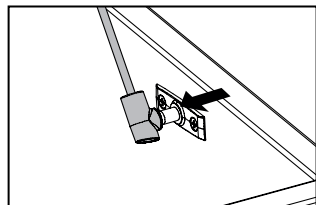
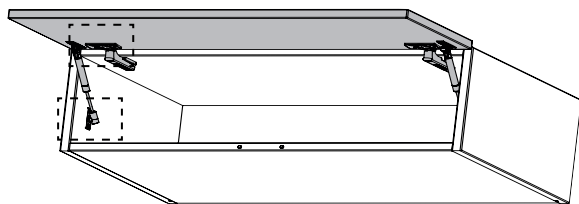

## 11.3 Hinged door

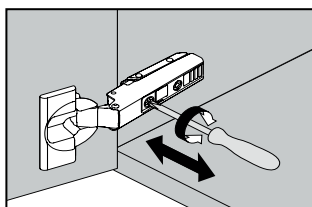
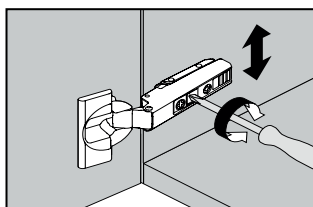
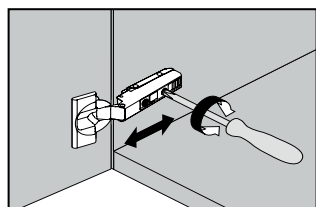
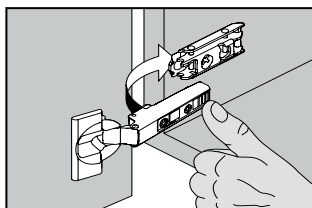
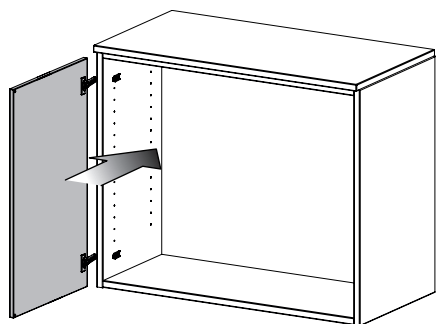

### 11.4.1 Castor-mounted drawer

Install castors

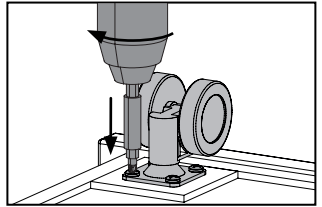
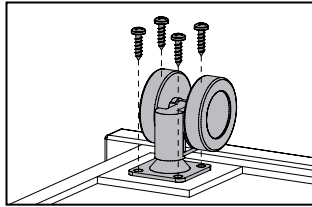
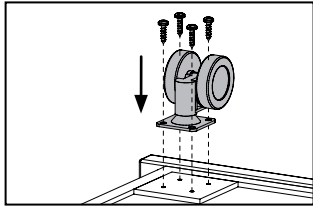
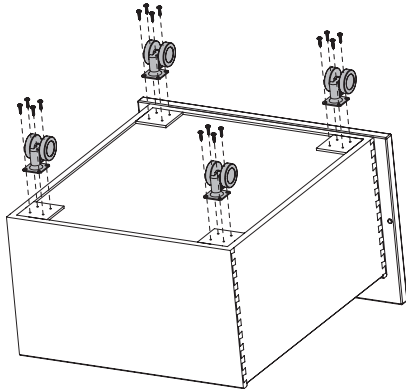

### 11.4.2 Optional: With large distance from front

Fit spacer plate

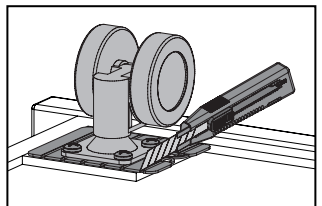
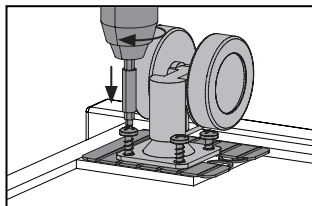
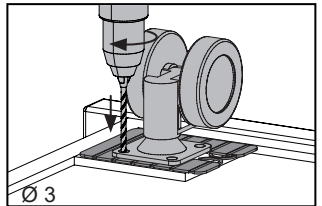
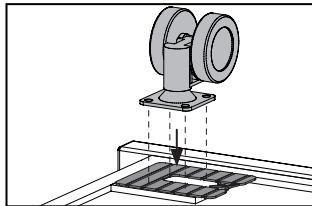
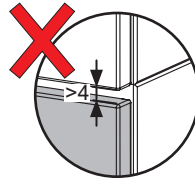
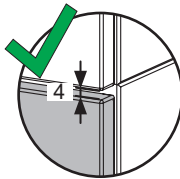
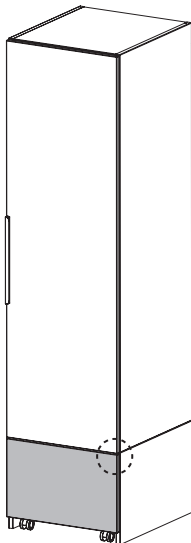
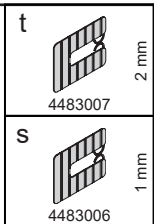

All measurements in millimetres!

### 11.4.3 Adjusting tambour door

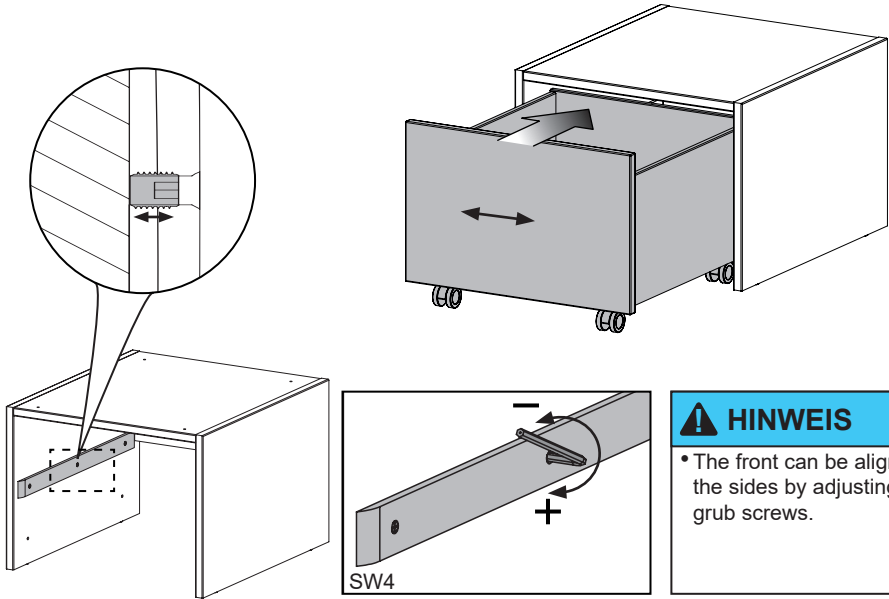

#### **HINWEIS**

- The front can be aligned with the sides by adjusting the grub screws.

### 11.5 Fit wall panel

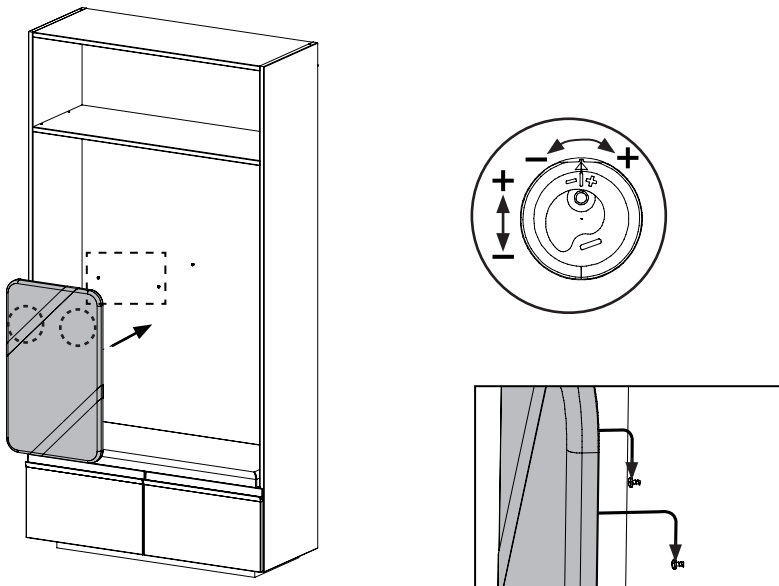

## 11.6 Switching light ON and OFF

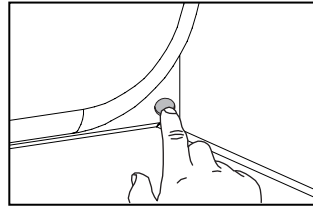
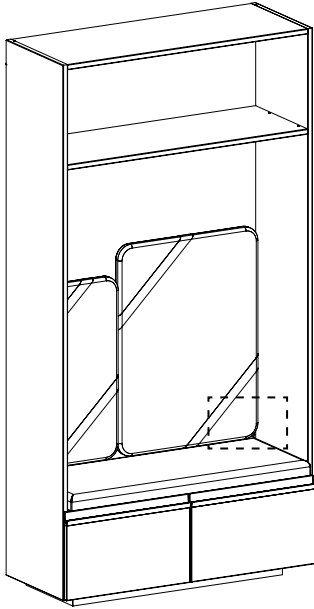

## 12. Interior partitioning

### 12.1 T-partitioning

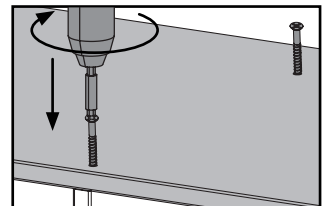
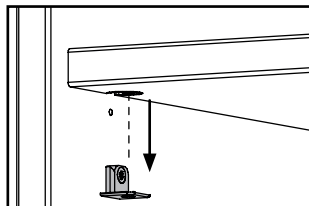
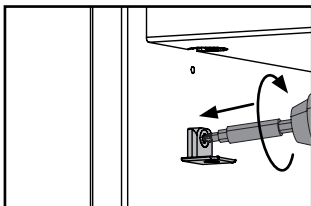
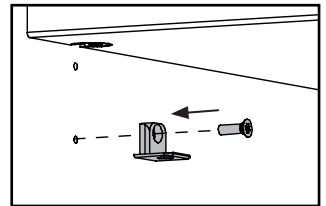
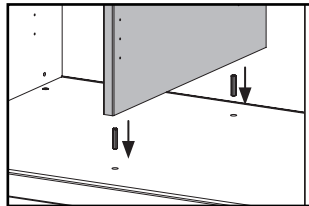
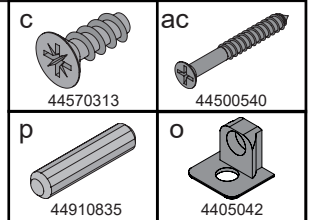
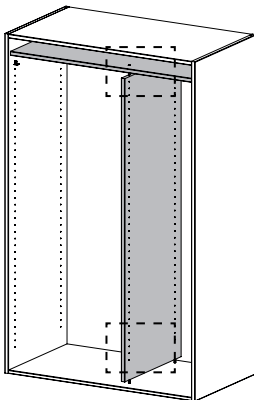

## 12.2 Clothes rail

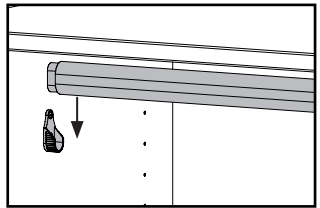
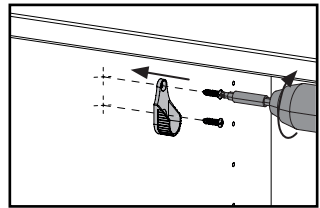
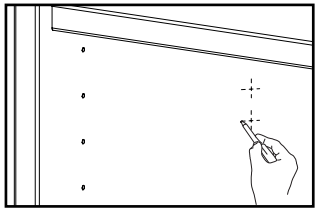
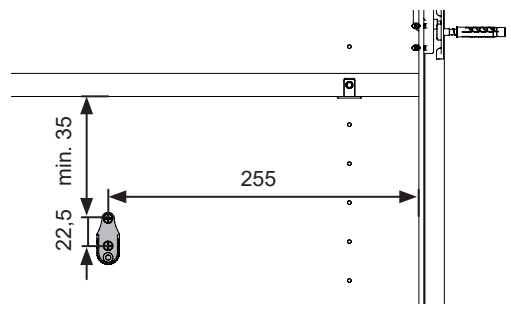
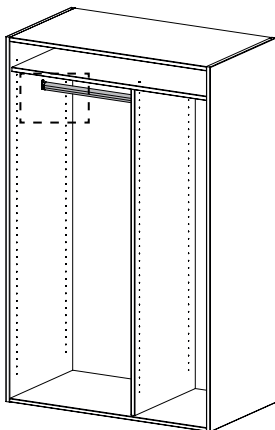
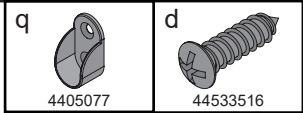

**All measurements in millimetres!**

## 12.3 Shelf with clothes rod

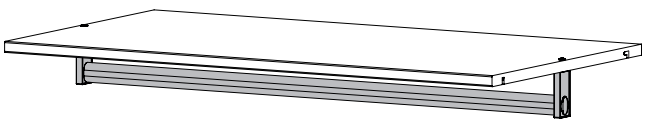
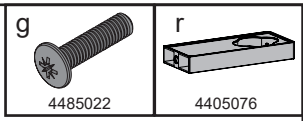

**Hinweis**

- Shelf with hole is provided for installation of the clothes rod.
- Recesses for shelf supports must be underneath.

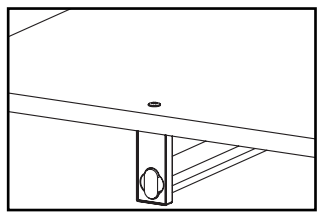
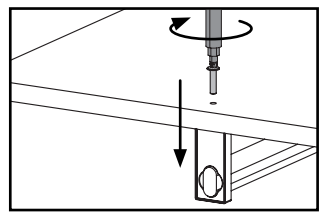
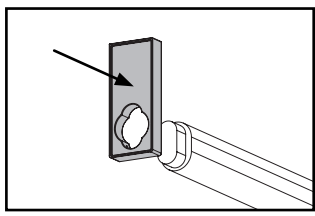

## 12.4 Theft-proof compartment

h

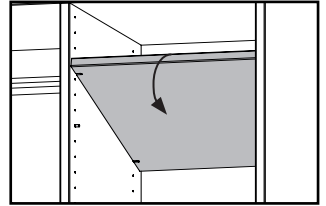
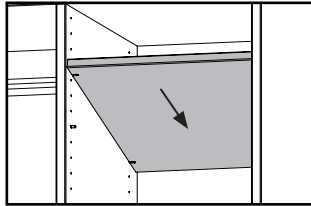
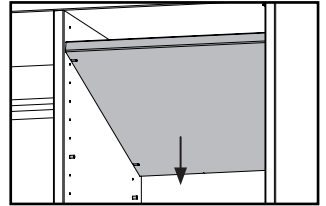
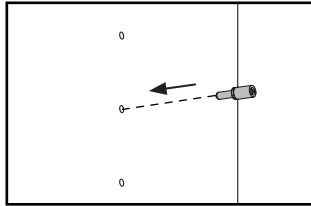
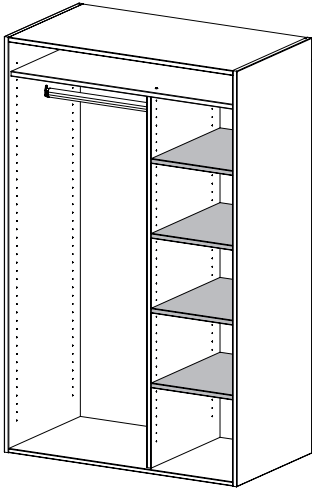
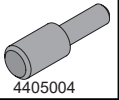

# TEAM 7

## **TEAM 7 Natürlich Wohnen GmbH**

Braunauer Str. 26  
4910 Ried im Innkreis, AUSTRIA

**Montagehotline: +43/7752-977321**

[www.team7-home.com](http://www.team7-home.com)

Errors and omissions excepted. All rights reserved for printing and typesetting errors.

### Copyright

All parts of this document are protected by copyright. Any use above and beyond the narrow confines of copyright law is not permitted without the consent of TEAM 7 GmbH and is a punishable offence. This applies in particular to reproduction, microfilming as well as saving and processing in electronic systems.