

TEAM 7



NR 00034

DIN EN 1725:1998-02

DIN EN 747-1:2012+A1:2015

Montageanleitung *Kids* Bettsystem

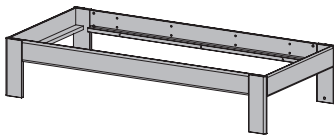

Einzelbett Basis

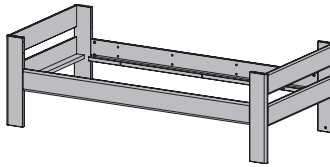

Einzelbett ohne Brüstung

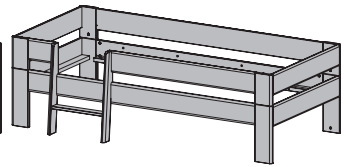

Einzelbett mit Brüstung

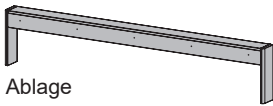

Ablage

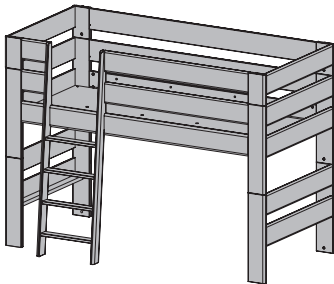

Höhlenbett

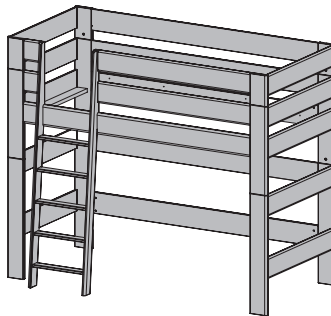

Hochbett

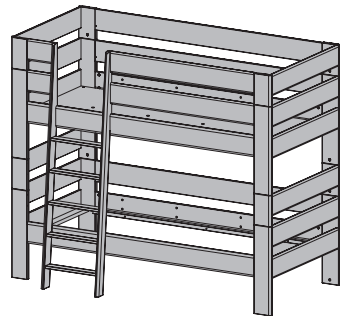

Etagenbett

DE

022023
TD280811B

Nach der Montage
zur Aufbewahrung für
unsere Kunden!

! RAUMKLIMA

- Ideales Raumklima für Menschen, Pflanzen und Naturholzmöbel ist:

**rel. Luftfeuchtigkeit: 40 bis 60% und eine
Raumtemperatur: 18° bis 23° Celsius.**

- Bei längeren Über- bzw. Unterschreitungen dieser Werte kommt es zu Schwind- bzw. Quellvorgängen. In Folge können Verzug, Risse, offene Leimfugen und raue Oberflächen auftreten.

! PFLEGE

- Pflegeanleitungen (Naturholz-, Leder-, Stoff-, Stricktex-, Stein-, Glas-, Filz-, Keramik-, Metall-, und Arbeitsplattenpflege) entnehmen Sie bitte der TEAM 7 Homepage.

- Wichtige produkt- und warentypische Eigenschaften der TEAM 7 Naturholzmöbel finden Sie auch in unserem Service- und Gütepass unter:

<https://www.team7-home.com/at/de/service/service-und-guetepass/>



! DOKUMENTATION

- Bewahren Sie alle Unterlagen zum Kauf Ihres Möbelstücks, auch über die gesetzliche Gewährleistungspflicht von zwei Jahren, sorgsam auf.
- Wenn Sie Ersatz- oder Ergänzungsteile benötigen, erleichtern Ihnen die Kaufunterlagen die genaue Auskunft über das von Ihnen erworbene Produkt.
- Bei Transportschäden Ihres Möbelstücks, sind Fotos des beschädigten Teils in der Originalverpackung zwingend notwendig.

Inhaltsverzeichnis

	Seite
1. WICHTIGE SICHERHEITSTECHNISCHE HINWEISE	3
2. Werkzeuge	4
3. Beschläge	4
4. Einzelbett	4 - 5
5. Ablage	5
6. Lattenrost	6
7. Brüstung	6 - 7
8. Aufsatz	8
9. Oberes Bett	9 - 10
10. Leiter	11
11. Brüstung mit Leiter	12 - 14
12. Abdeckschrauben	15
13. Abdeckstoppel	16

1. WICHTIGE SICHERHEITSTECHNISCHE HINWEISE

WICHTIG - SORGFÄLTIG LESEN UND AUFBEWAHREN!

- Bitte lesen Sie die mitgelieferte Dokumentation vor der Montage durch und bewahren Sie die Anleitungen für den späteren Gebrauch auf.
- **WARNUNG:** Hochbetten und das obere Bett von Etagenbetten sind für Kinder unter 6 Jahren aufgrund von Verletzungsgefahr durch Herabfallen nicht geeignet.
- **WARNUNG:** Bei unsachgemäßem Gebrauch können Etagenbetten und Hochbetten eine ernste Verletzungsgefahr durch Strangulation darstellen. Gegenstände, die nicht für den Gebrauch mit dem Bett bestimmt sind, dürfen niemals an einem Teil des Etagenbettes befestigt oder aufgehängt werden, dies gilt z.B., aber nicht ausschließlich, für Seile, Schnüre, Kordeln, Haken, Gürtel und Taschen.
- **WARNUNG:** Kinder können zwischen dem Bett und der Wand eingeklemmt werden. Um ernste Verletzungsgefahren zu vermeiden, darf der Abstand zwischen der Oberkante der Absturz-Sicherung und der Wand höchstens 75 mm betragen oder der Abstand muss größer sein als 230 mm.
- **WARNUNG:** Das Etagenbett darf nicht benutzt werden, wenn Teile beschädigt oder defekt sind, ausgerissen sind oder fehlen.
- Alle Verbindungselemente müssen bei der Montage fest angezogen werden und dürfen während des Gebrauchs nicht gelöst werden. Alle Verbindungsmittel sind regelmäßig auf festen Sitz zu Prüfen.
- Sämtliche Ersatzteile und zusätzliche Anbauteile dürfen nur über TEAM 7 bezogen werden.
- Die Anleitung und Hinweise von Team 7 sind stets zu befolgen.
- Empfohlene Matratzengröße(n): 2000mm x 900mm / 2000mm x 1000mm
2000mm x 1400mm
- Die maximale Matratzenhöhe darf auf keinen Fall überschritten werden!
- Um die Luftfeuchte niedrig zu halten, um damit Schimmelbildung in und um das Bett zu vermeiden, ist ausreichend Raumbelüftung notwendig.

2. Werkzeuge

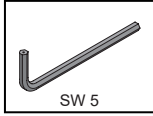
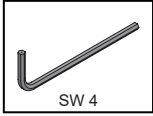
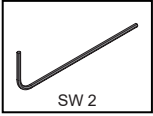
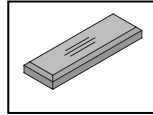
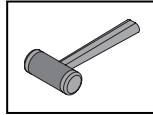
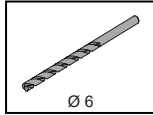
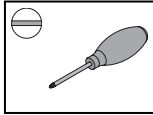
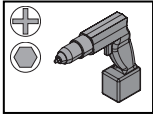

3. Beschläge

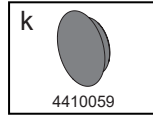
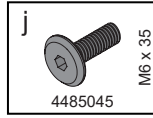
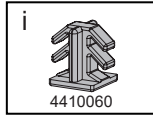
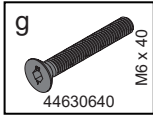
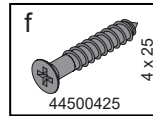
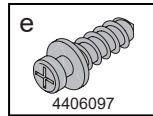
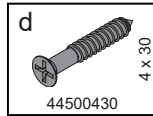
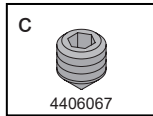
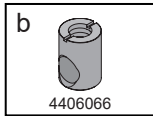
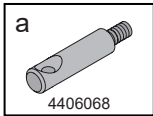

4. Einzelbett

4.1 Stahldübel eindrehen

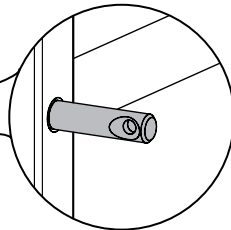
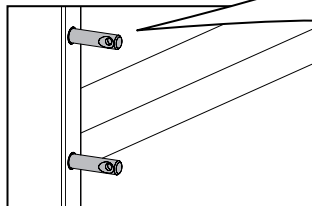
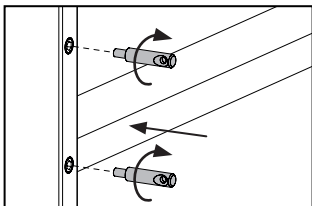
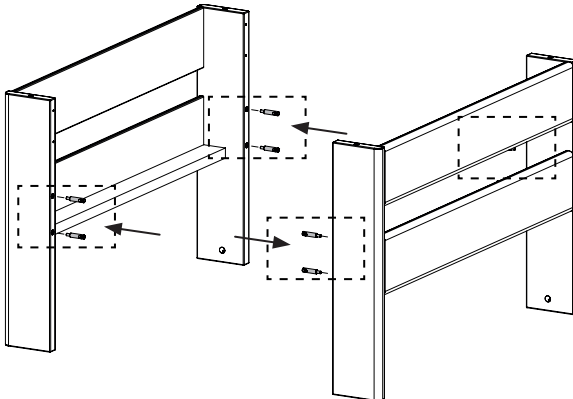
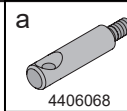

4.2 Gehäuse einstecken

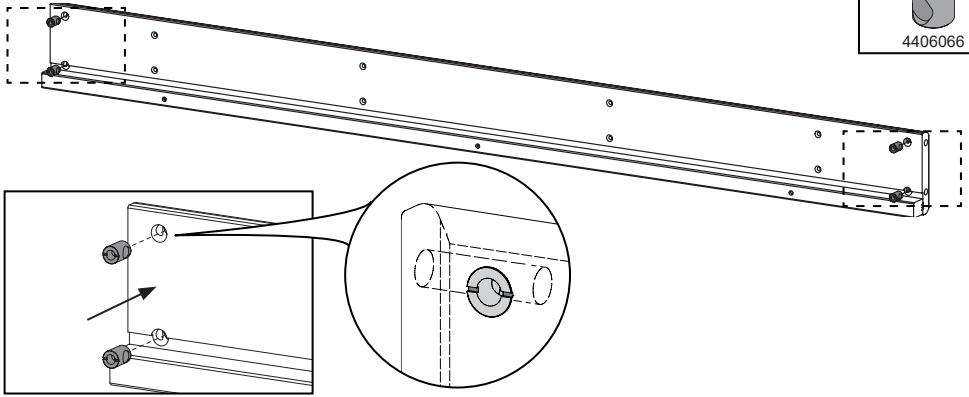
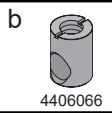

4.3 Bettseiten montieren

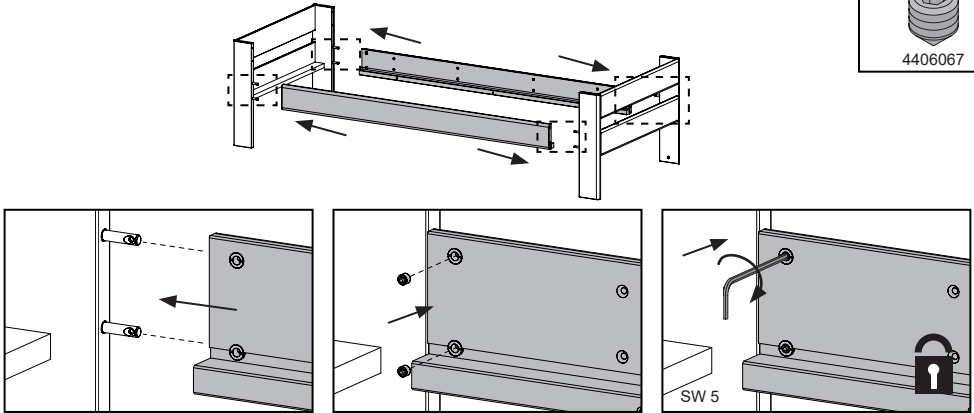
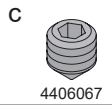

5. Optional: Ablage

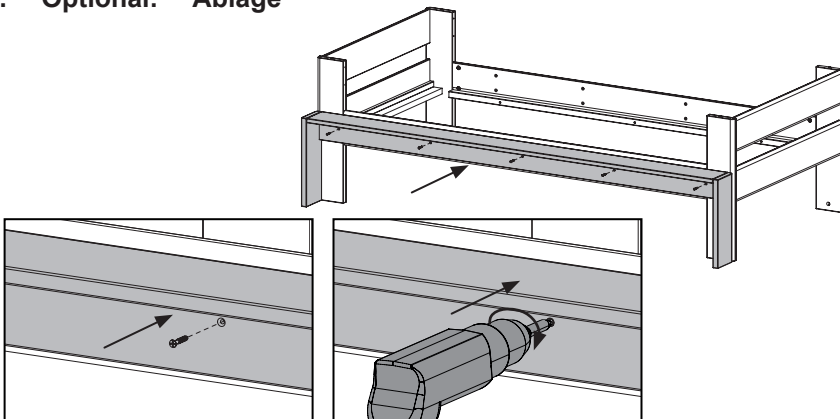
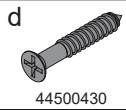

6. Lattenrost

6.1 Lattenrost einlegen

HINWEIS

- Bei Etagenbetten muss der Lattenrost vor der Stapelung eingelegt werden.

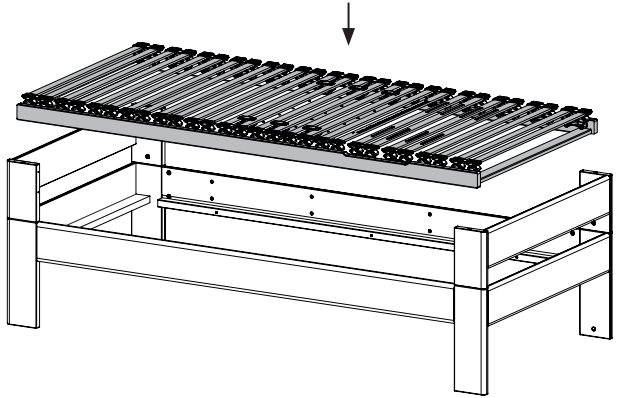

6.2 Abstandsleiste einlegen

HINWEIS

- Um ein Verschieben des Lattenrosts zu vermeiden, müssen je nach Länge der Lattenrosts 1 - 2 Abstandsleisten eingelegt werden.

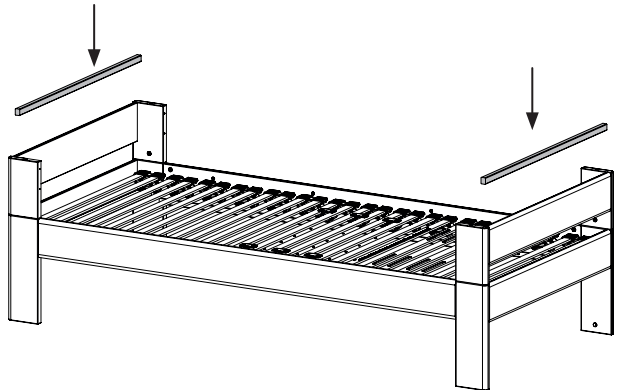

7. Brüstung

7.1 Verbindungsschrauben eindrehen

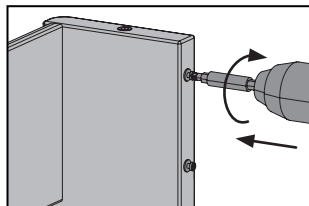
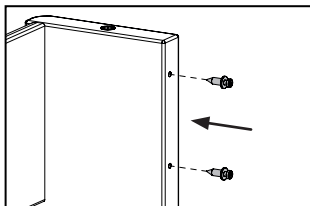
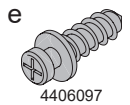

7.2 Brüstungsbrett montieren

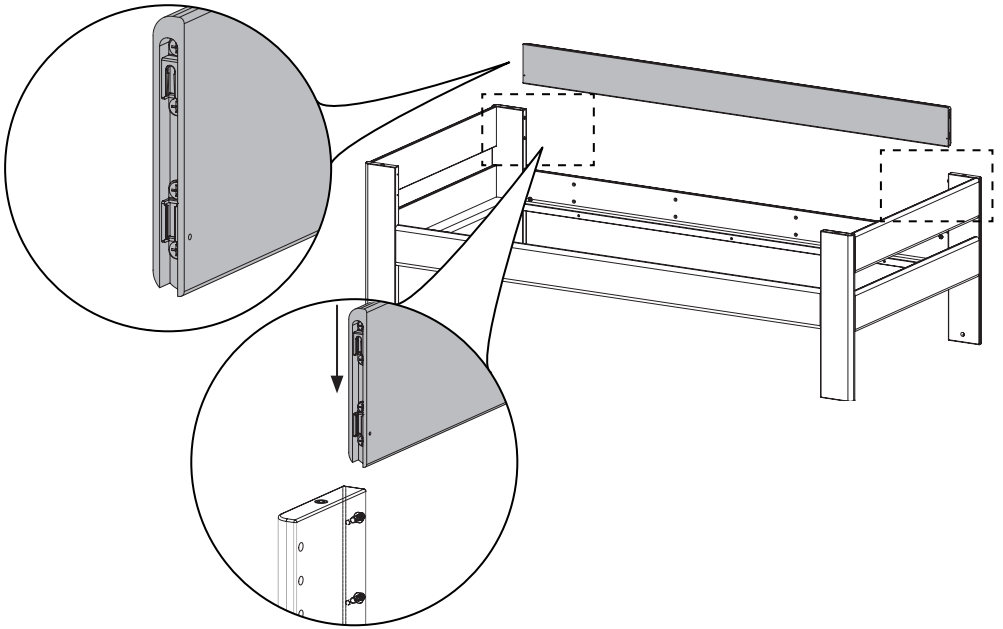

7.3 Brüstungsbrett fixieren

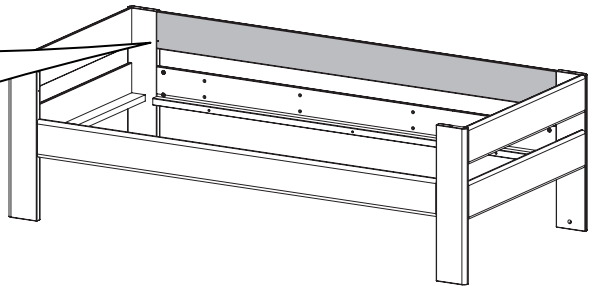
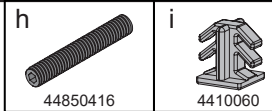
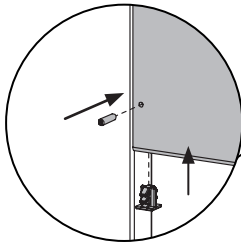

ACHTUNG

- Madenschraube flächenbündig eindrehen!

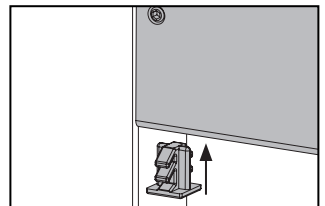
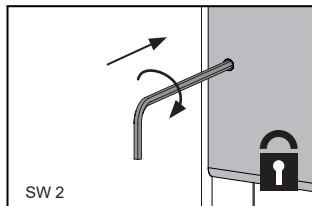
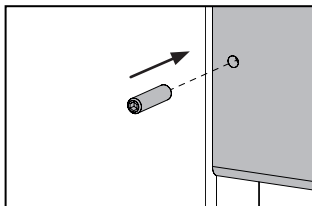

8. Aufsatz

8.1 Stahldübel eindrehen

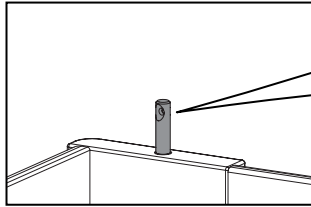
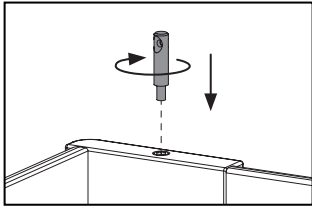
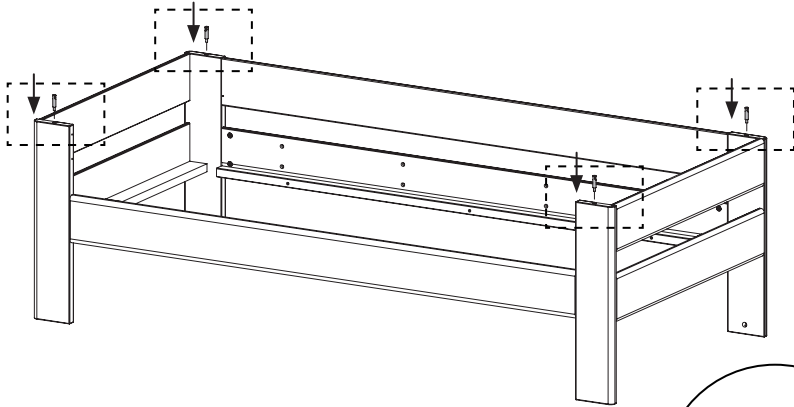
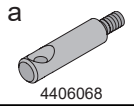

8.2 Bettauflsatz montieren

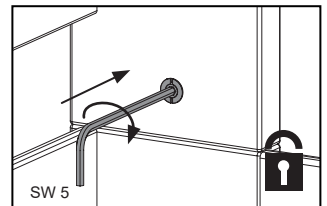
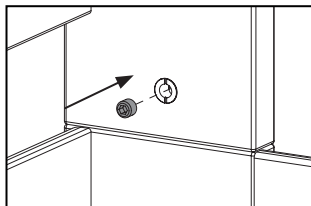
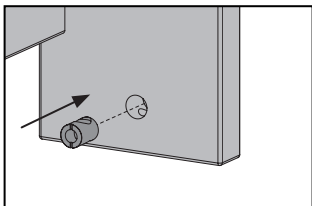
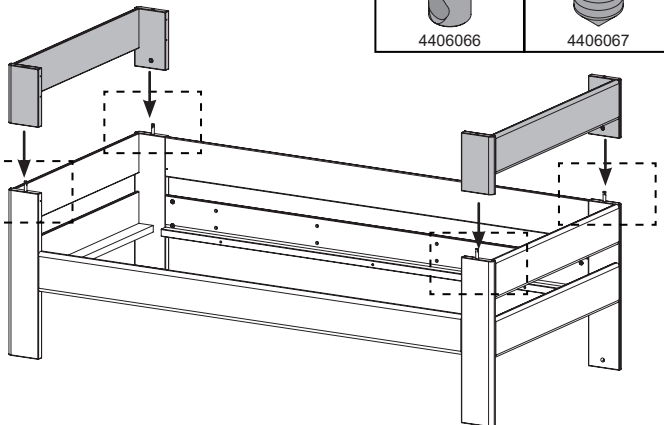
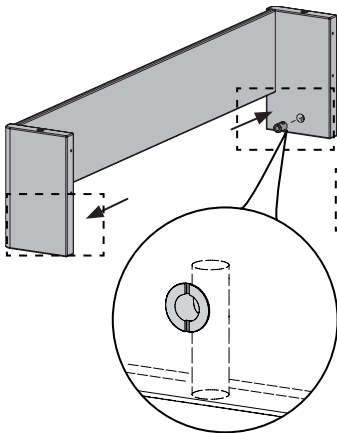
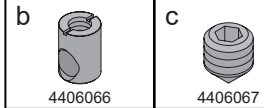

9. Oberes Bett

9.1 Stahldübel eindrehen

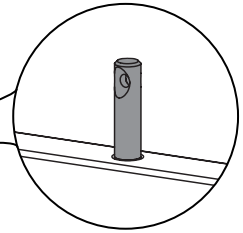
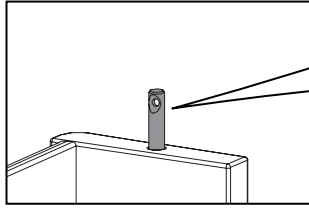
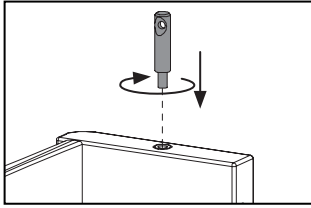
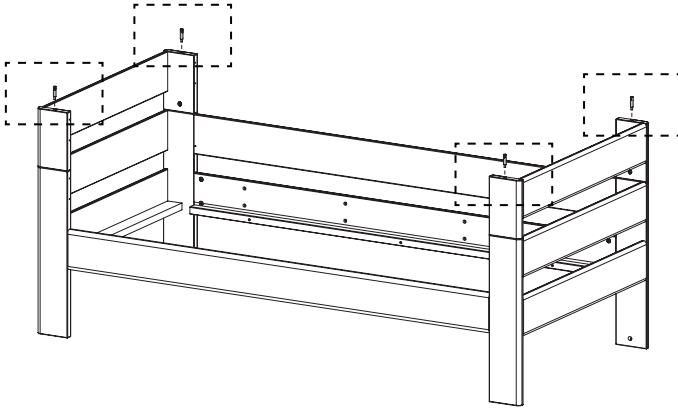
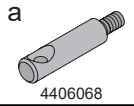

9.2 Betten verbinden

HINWEIS

- Für oberes Bett Schritt 4 wiederholen

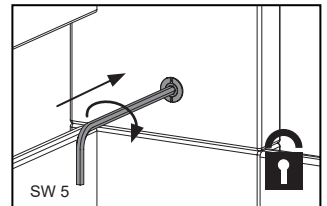
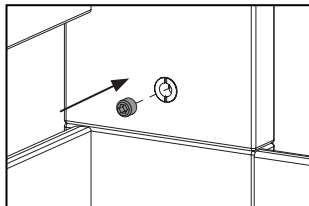
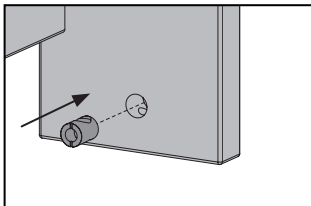
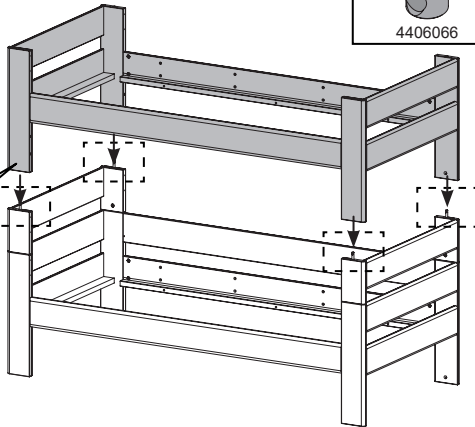
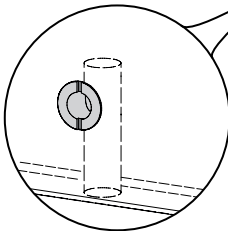
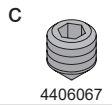
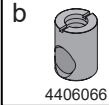

9.3 Zwischenboden montieren

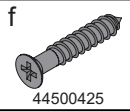

HINWEIS

- Zwischenboden wird nur bei oberem Bett montiert.

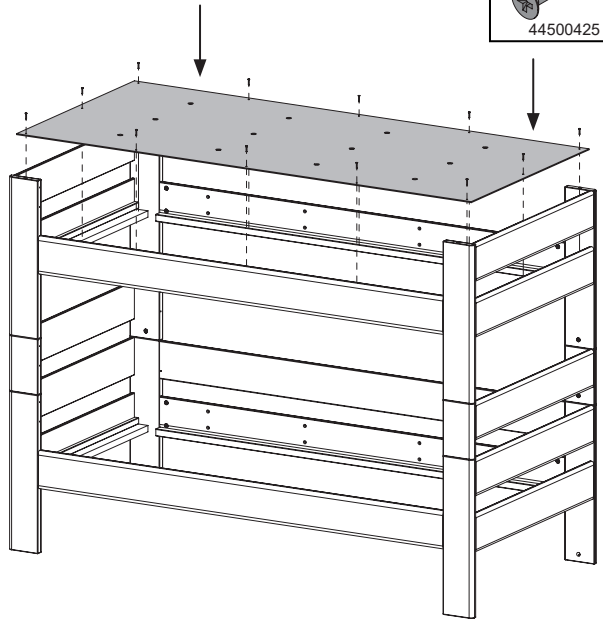
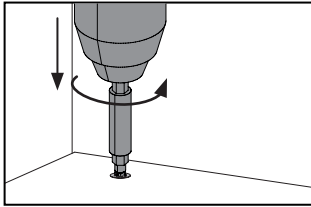

9.4 Verbindungsschrauben eindrehen

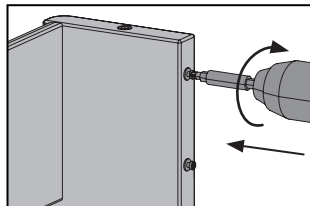
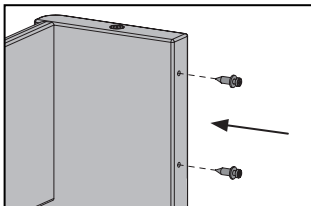
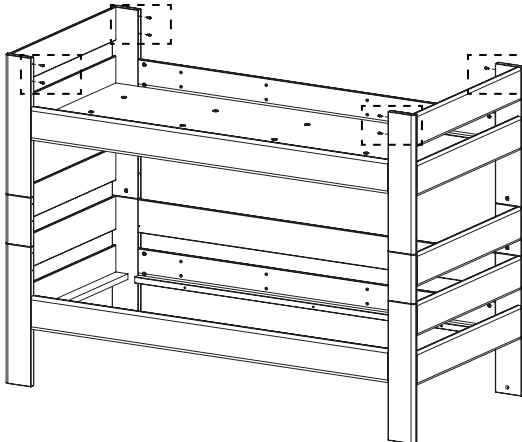
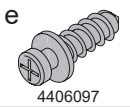

10. Leiter

10.1 Verbindungsschrauben eindrehen

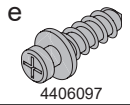

Maximale Matratzenhöhe

⚠ ACHTUNG

- Die maximale Matratzenhöhe darf auf keinen Fall überschritten werden!

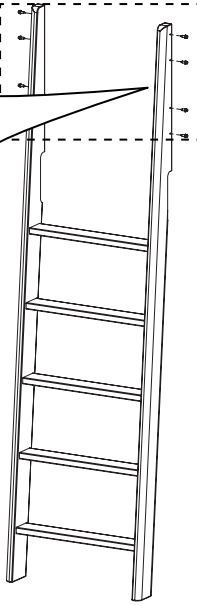
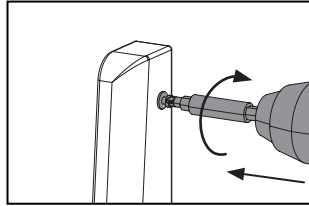
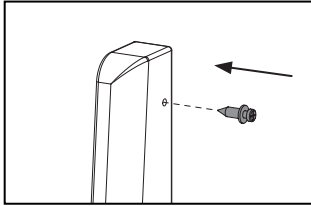
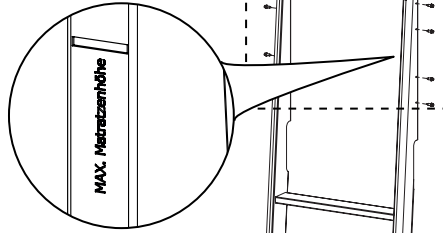

10.2 Leiter montieren

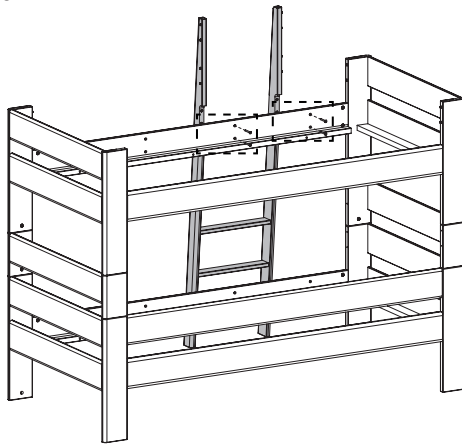

⚠ HINWEIS

- Die Leiter kann frei an den 4 vorgekürnten Positionen befestigt werden

⚠ ACHTUNG

- Beim Durchbohren unbedingt Zulage verwenden! Ausrissgefahr!

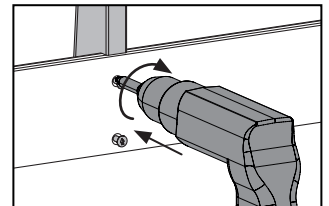
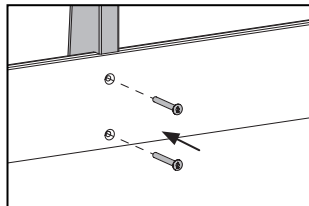
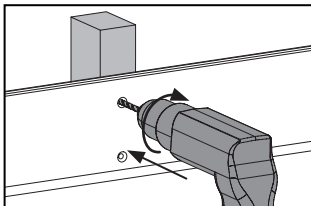

11. Brüstung mit Leiter

11.1 Brüstungsbretter montieren

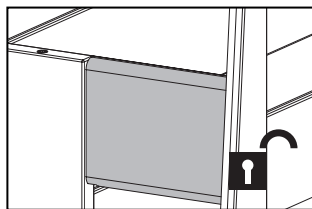
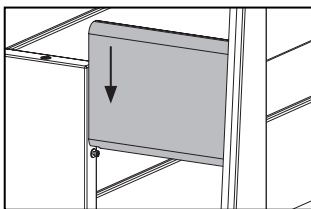
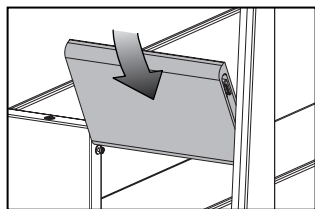
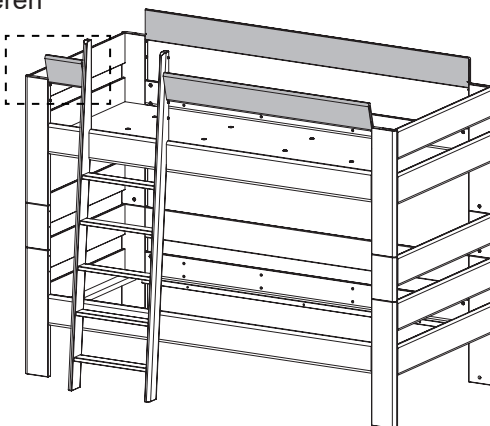

11.2 Brüstungsbrett fixieren

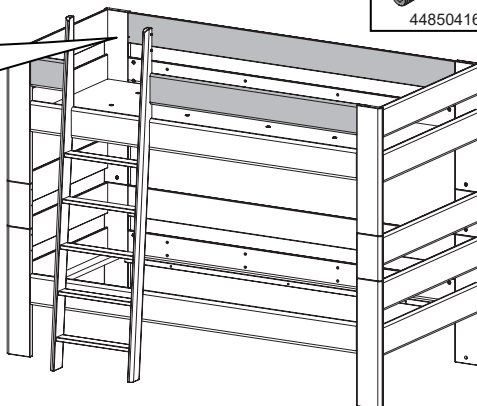
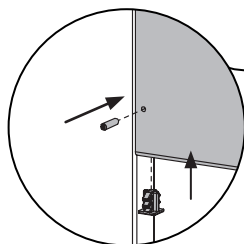

⚠ ACHTUNG

- Madenschraube flächenbündig eindrehen!

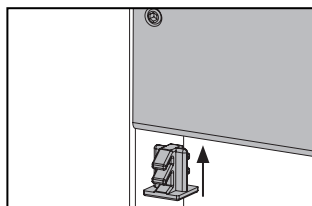
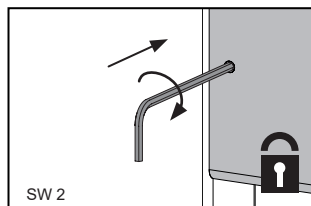
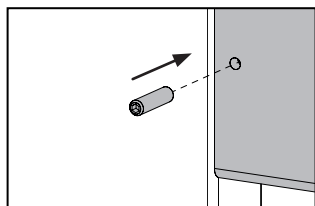

11.3 Stahldübel eindrehen

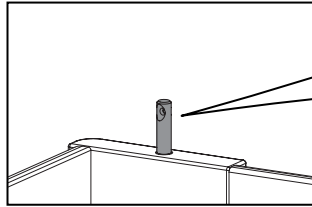
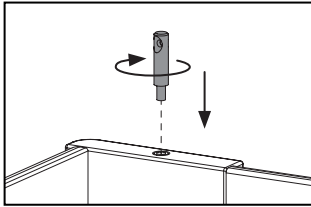
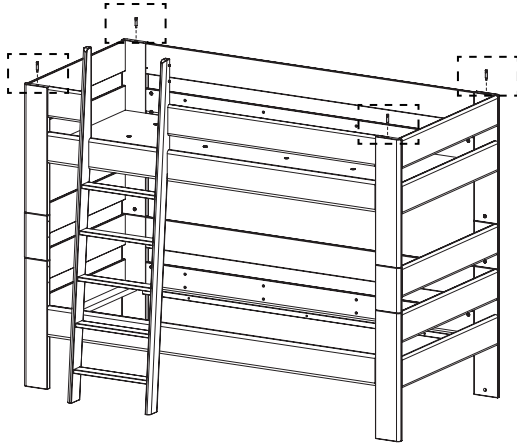
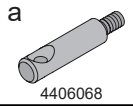

11.4 Beschläge an Bettauflauf montieren

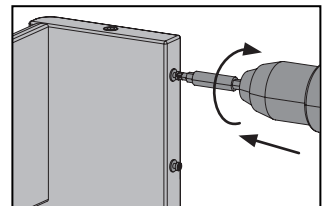
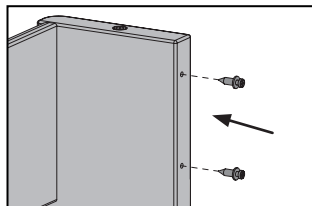
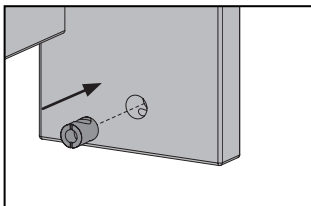
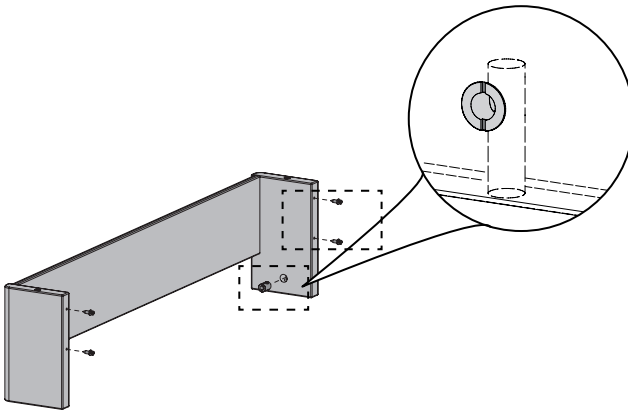
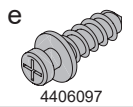
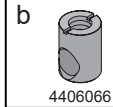

11.5 Bettaufsatz montieren

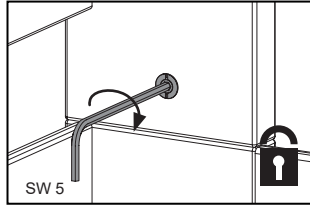
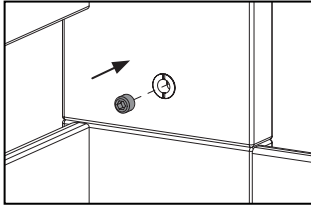
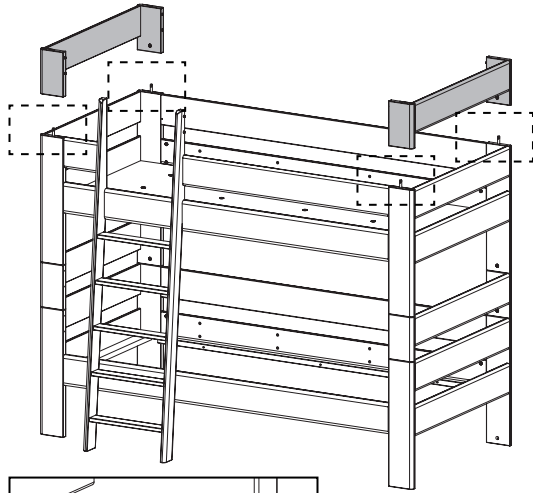
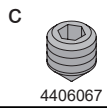

11.6 Brüstungsbretter montieren

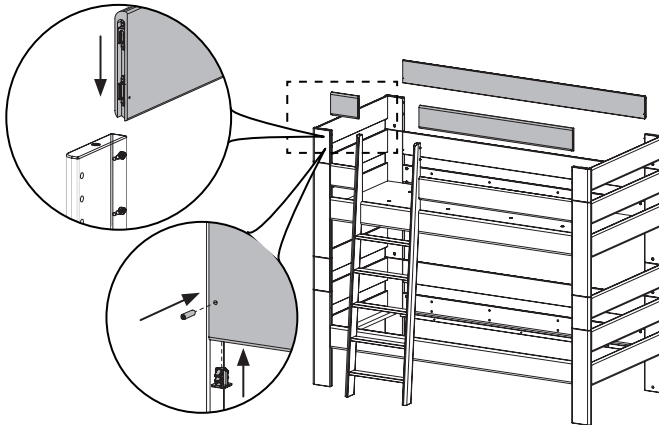

⚠ ACHTUNG

- Madenschraube flächenbündig eindrehen!

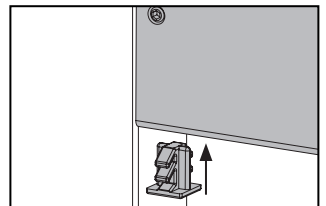
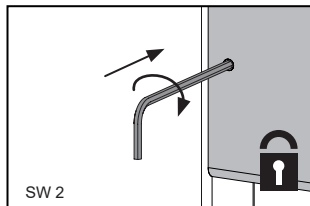
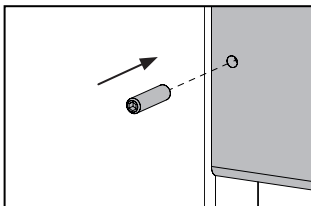

12. Abdeckschrauben

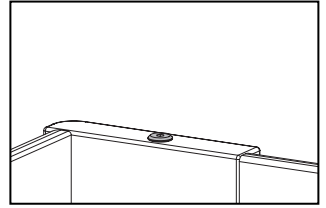
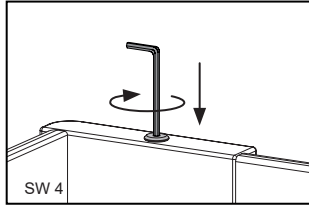
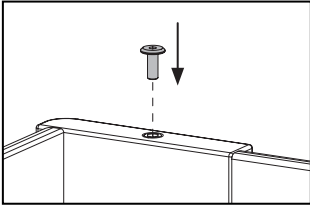
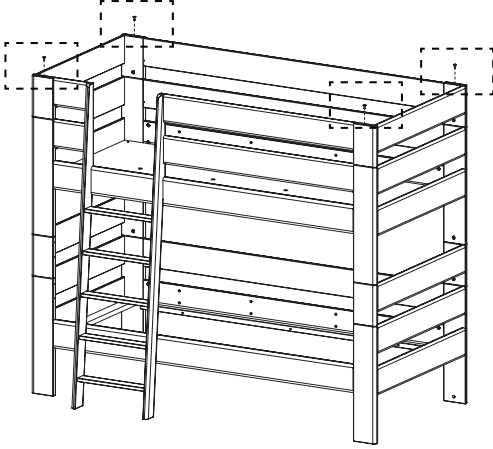
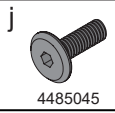

Nur bei Höhlenbett:

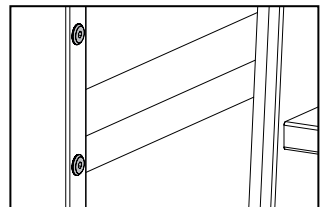
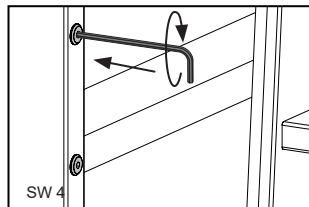
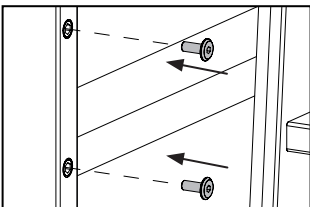
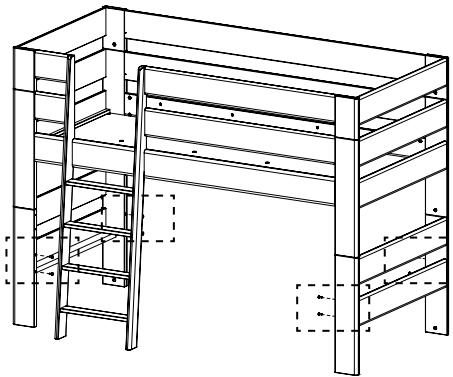

13. Abdeckstoppel

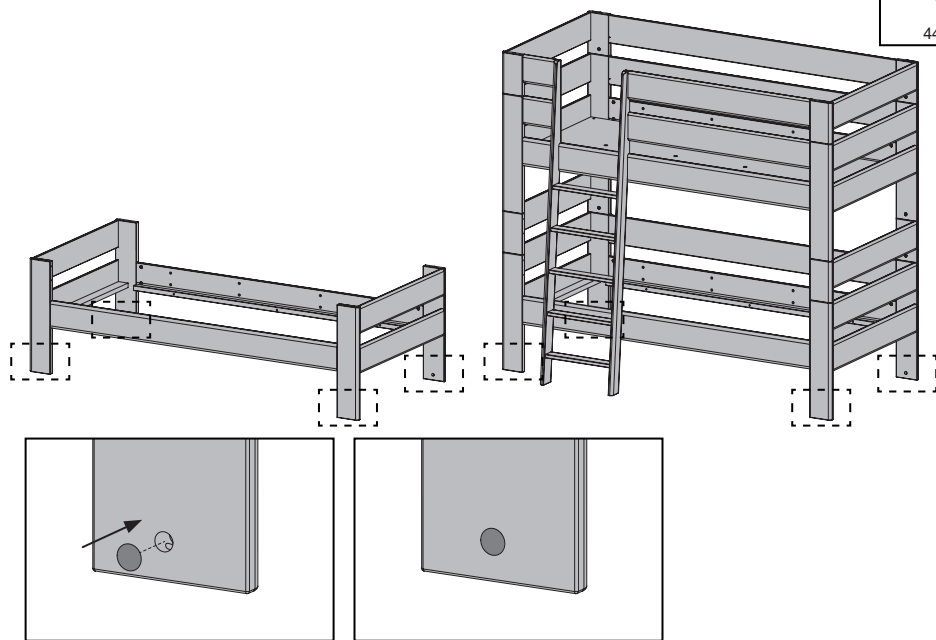

TEAM 7

TEAM 7 Natürlich Wohnen GmbH

Braunauer Str. 26

4910 Ried im Innkreis, AUSTRIA

Montagehotline: +43/7752-977321

www.team7-home.com

Änderungen, Irrtümer, Druck- und Satzfehler vorbehalten

Urheberrecht

Das Werk einschließlich aller Teile ist urheberrechtlich geschützt. Jede Verwertung außerhalb der engen Grenzen des Urheberrechtsgesetzes ist ohne Zustimmung der Firma TEAM 7 GmbH unzulässig und strafbar. Das gilt insbesondere für Vervielfältigung, Mikroverfilmung und die Einspeicherung und Verarbeitung in elektrische Systeme.

TEAM 7



NR 00034

DIN EN 1725:1998-02

DIN EN 747-1:2012+A1:2015

Instructions de montage

Kids

Lit modulaire

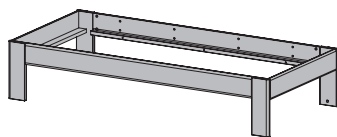

Lit 1 personne base

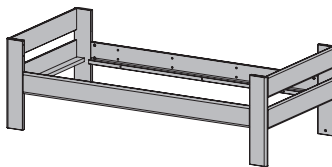

Lit 1 personne sans rambarde

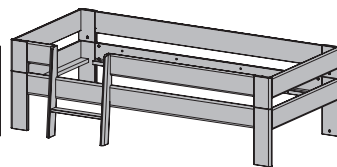

Lit 1 personne avec rambarde

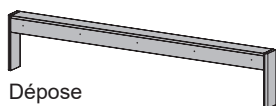

Dépose

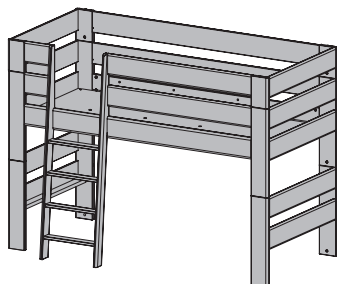

Lit caverne

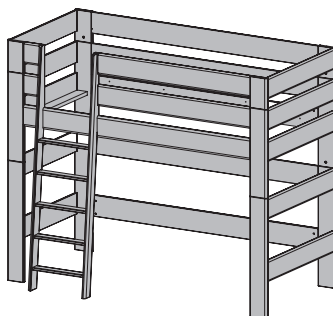

Lit haut

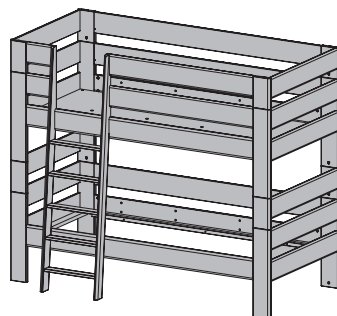

Lit jumeaux

FR

CLIMAT INTERIEUR

- Climat intérieur idéal pour les personnes, les plantes et les meubles en bois naturel :

**une humidité relative comprise entre 40 et 60 % et
Température ambiante : de 18 à 23 °C.**

- Le dépassement supérieur et/ou inférieur prolongé de ces valeurs entraîne une rétraction ou un gonflement de ce matériau. Risque de déformation, fissure, joint décollé et surface rugueuse.

ENTRETIEN

- Les consignes d'entretien sont disponibles sur le site Internet TEAM 7 (entretien du bois naturel, du cuir, de l'étoffe, du Stricktex, de la pierre, du verre, métal, céramique du feutre et des plans de travail)
- Vous trouverez d'importantes caractéristiques des meubles en bois naturel TEAM 7 également dans le certificat de service et de qualité à l'adresse suivante :

<https://www.team7-home.com/at/de/service/service-und-guetepass/>



DOCUMENTATION

- Veuillez conserver soigneusement tous les documents d'achat de votre meuble, même au-delà de la garantie légale de deux ans.
- S'il vous faut des pièces de rechange ou des accessoires, tous les renseignements concernant le produit que vous aurez acheté figurent sur ces documents.
- Si votre meuble a été endommagé durant le transport, joindre impérativement des photos de la partie endommagée dans l'emballage d'origine.

Sommaire

côté

1. CONSIGNES DE SÉCURITÉ IMPORTANTES	3
2. Outils	4
3. Ferrures	4
4. Lit 1 personne	4 - 5
5. Dépose	5
6. Sommier à lattes	6
7. Rambarde	6 - 7
8. Élément à poser	8
9. Lit supérieur	9 - 10
10. Echelle	11
11. Rambarde avec escabeau	12 - 14
12. Vis	15
13. Bouchon	16

1. CONSIGNES DE SÉCURITÉ IMPORTANTES

IMPORTANT - LIRE ATTENTIVEMENT ET CONSERVER !

- Avant le montage, veuillez lire les documents joints à la livraison. Conservez les instructions pour une utilisation ultérieure.
- **ATTENTION** : les lits hauts, ainsi que le lit supérieur des lits jumeaux ne conviennent pas aux enfants de moins de 6 ans en raison du risque de blessures par chute.
- **ATTENTION** : en cas d'utilisation non conforme, sérieux risque de suffocation par étranglement associé aux lits jumeaux et aux lits hauts. Défense absolue de fixer ou d'accrocher tout objet non prévu pour être utilisé avec le lit, par ex. cordes, ficelles, cordons, crochets, ceintures et sacs (liste non exhaustive).
- **ATTENTION** : Les enfants risquent de se coincer entre le lit et le mur. Afin d'éviter les risques de blessures graves, l'écart entre le chant supérieur du dispositif antichute et le mur ne doit pas dépasser 75 mm ou bien il doit être supérieur à 230 mm.
- **ATTENTION**: Ne pas utiliser le lit jumeaux en cas de pièces endommagées ou défectueuses, arrachées ou manquantes.
- Tous les éléments de raccord doivent être bien serrés lors du montage et ne surtout pas être desserrés lors de l'utilisation. Vérifier régulièrement le serrage de tous les moyens de raccord.
- Toutes les pièces de rechange et pièces complémentaires doivent être commandées exclusivement auprès de TEAM 7.
- Il convient de respecter les instructions et les consignes données par TEAM 7.
- Dimensions de matelas recommandées : 2000mm x 900mm / 2000mm x 1000mm
2000mm x 1400mm
- La hauteur maximum de matelas ne doit en aucun cas être dépassée !
- Afin de maintenir l'humidité de l'air à un faible niveau et donc d'éviter toute formation de moisissures dans et autour du lit, il faut aérer la pièce.

2. Outils

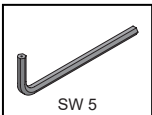
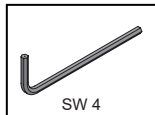
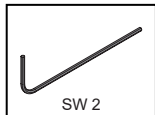
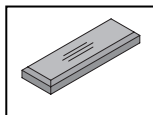
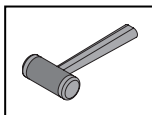
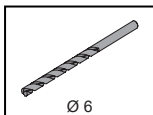
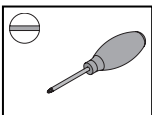
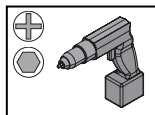

3. Ferrures

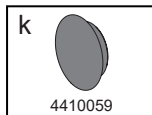
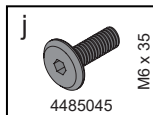
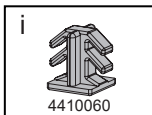
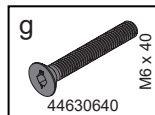
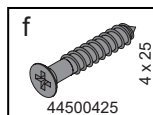
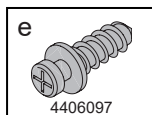
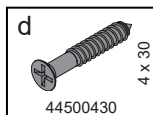
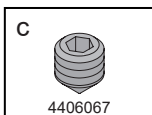
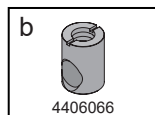
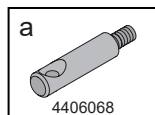

4. Lit 1 personne

4.1 Visser les chevilles en acier

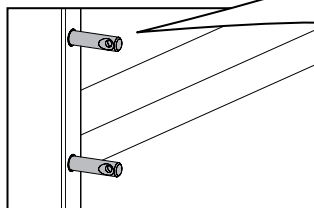
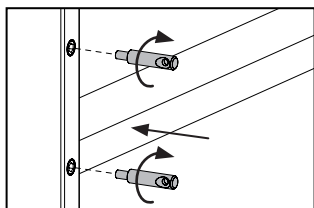
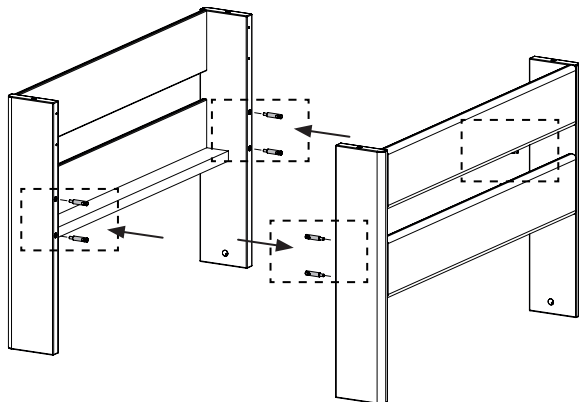

4.2 Insérer le boîtier

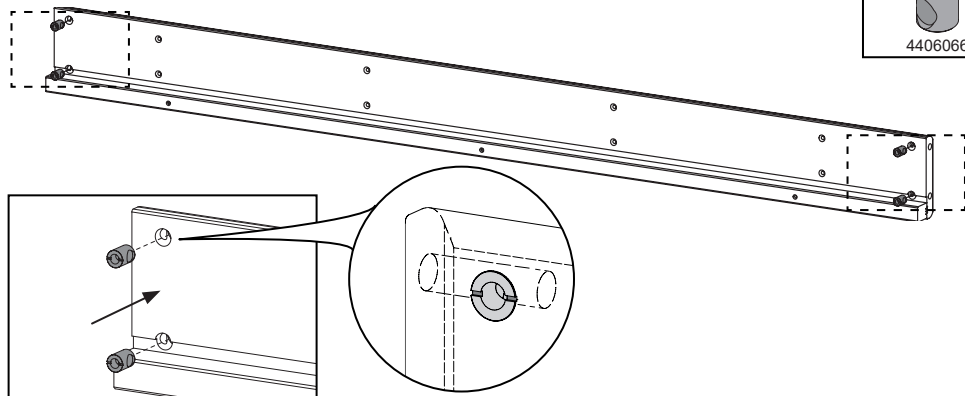
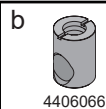

4.3 Monter parois latérales de lit

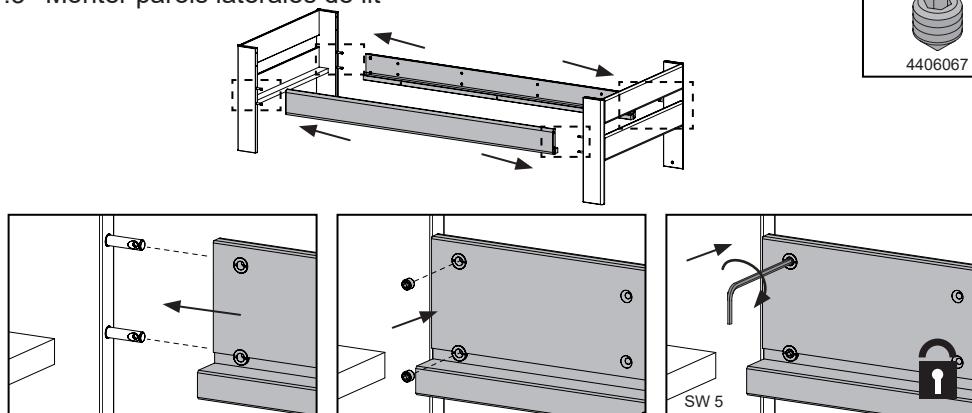
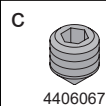

5. En option : Dépose

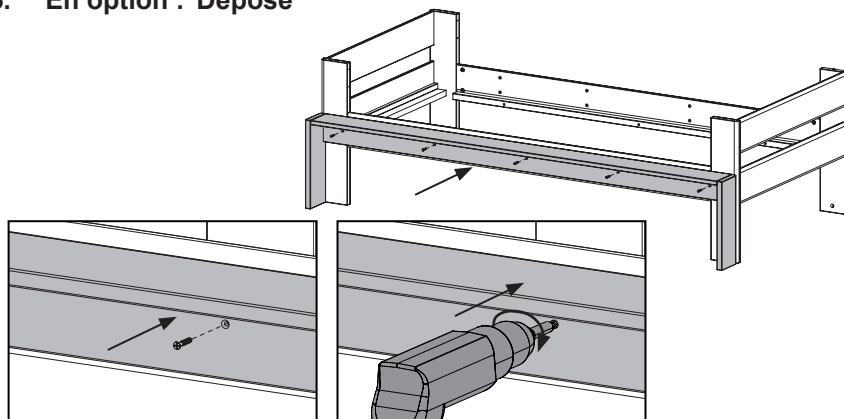
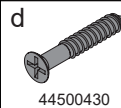

6. Sommier à lattes

6.1 Insérer le sommier à lattes

REMARQUE

- Pour les lits jumeaux, le sommier à lattes doit être mis en place avant l'empilage.

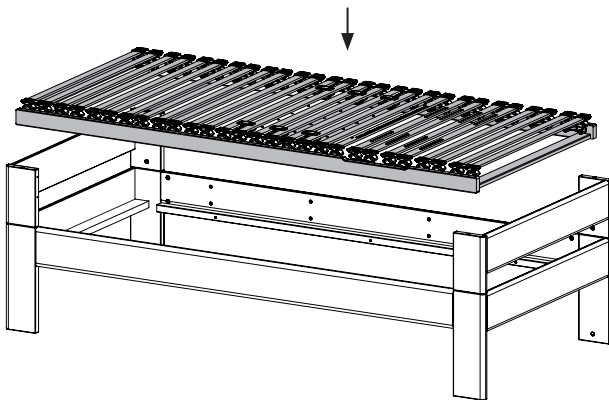

6.2 Insérer la cale

REMARQUE

- Pour éviter qu'il ne se déplace, prévoir 1 ou 2 cales selon la longueur du sommier à lattes.

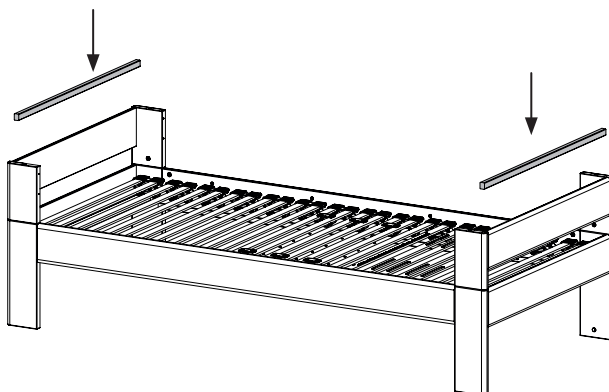

7. Rambarde

7.1 Serrer les vis d'assemblage

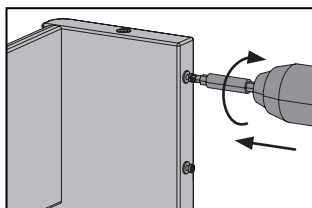
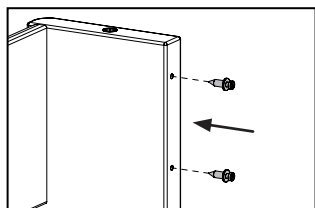
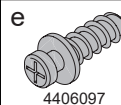

7.2 Monter la planche de rambarde

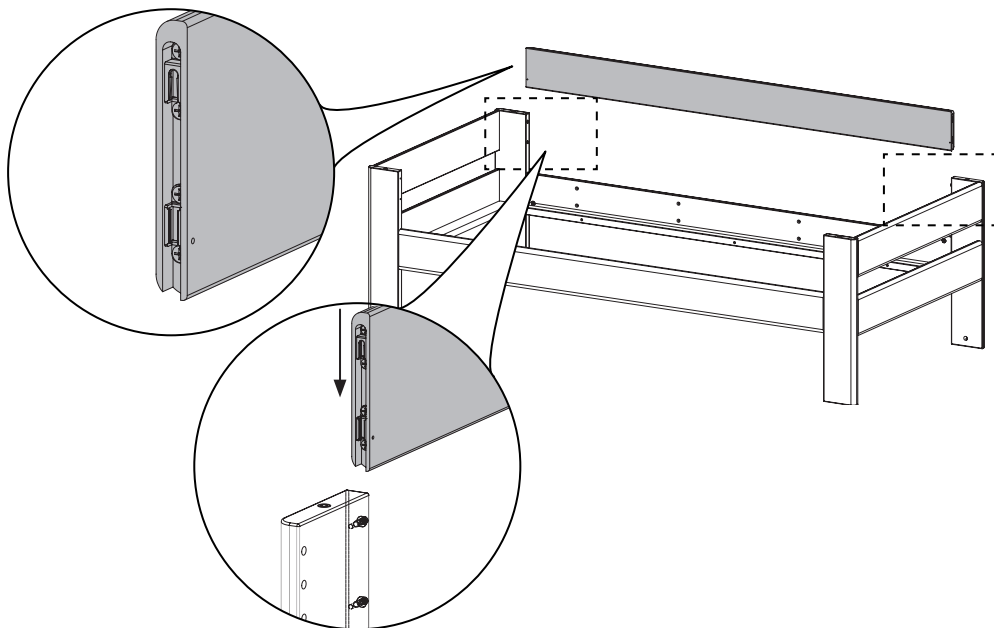

7.3 Fixer la planche de rambarde

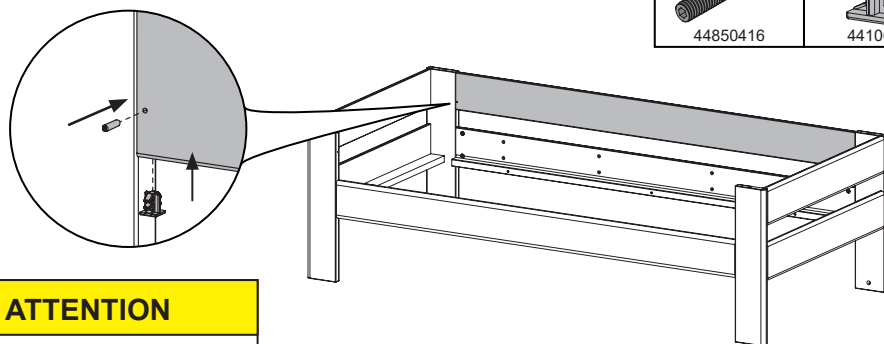
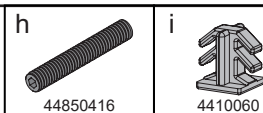

ATTENTION

- Serrer la vis sans tête à fleur !

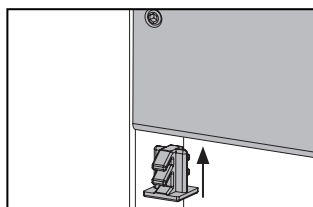
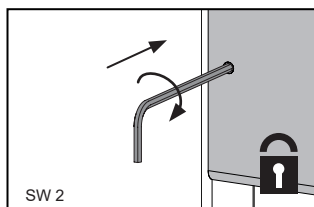
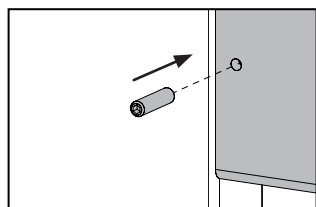

8. Élément à poser

8.1 Visser les chevilles en acier

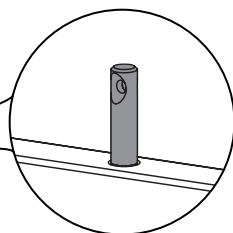
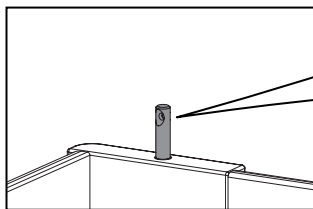
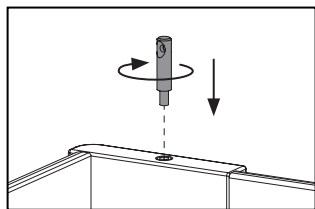
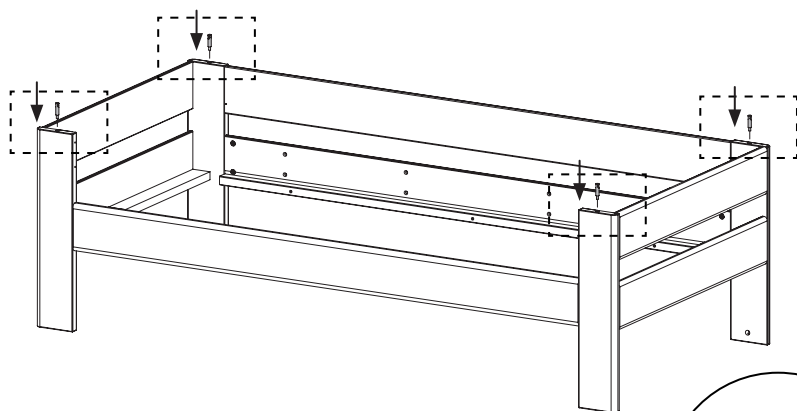
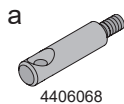

8.2 Monter l'élément à poser du lit

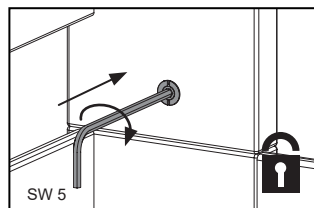
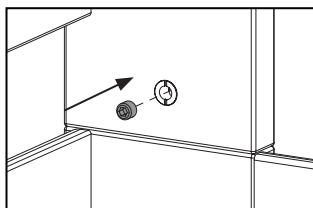
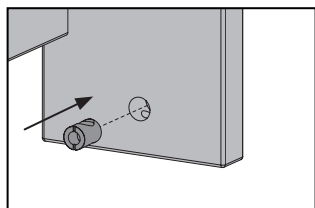
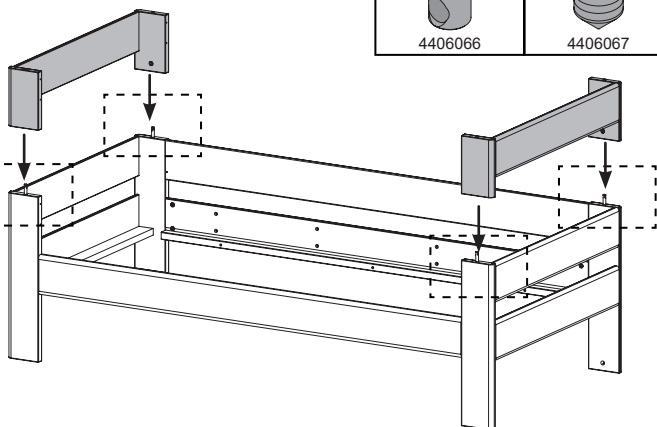
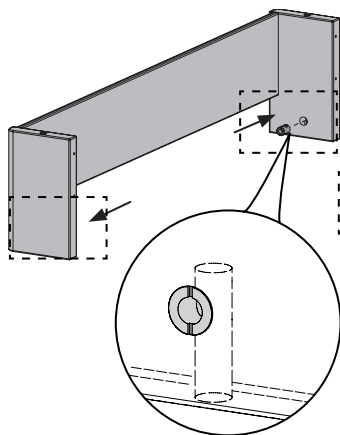
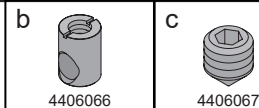

9. Lit supérieur

9.1 Visser les chevilles en acier

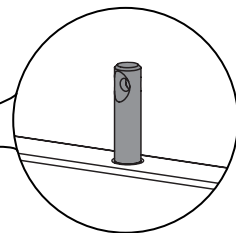
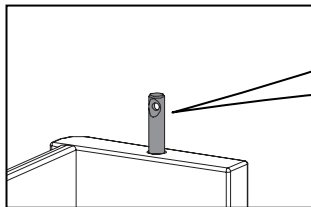
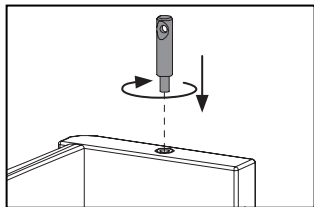
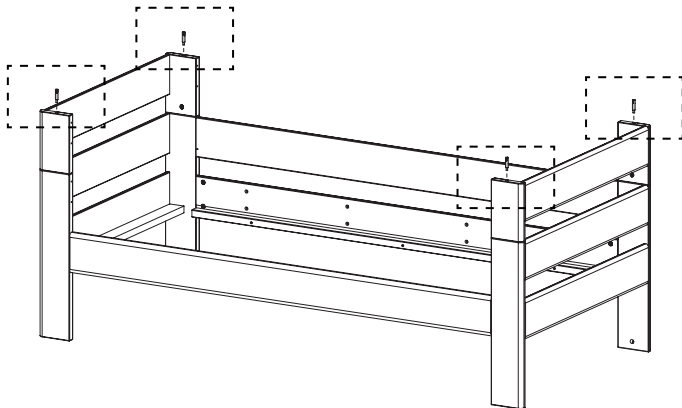
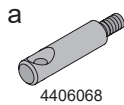

9.2 Assembler les lits

REMARQUE

- Pour le lit supérieur, répéter l'étape 4

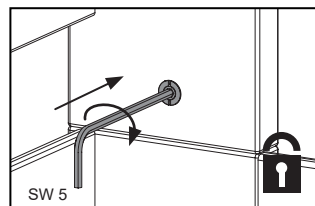
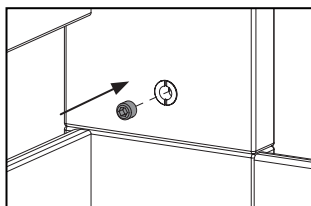
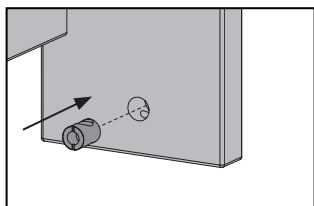
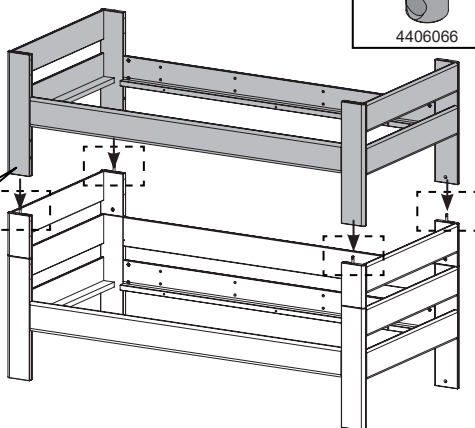
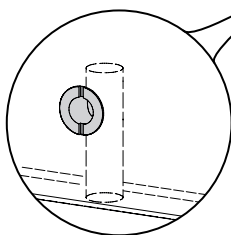
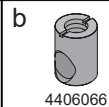

9.3 Monter la tablette intermédiaire

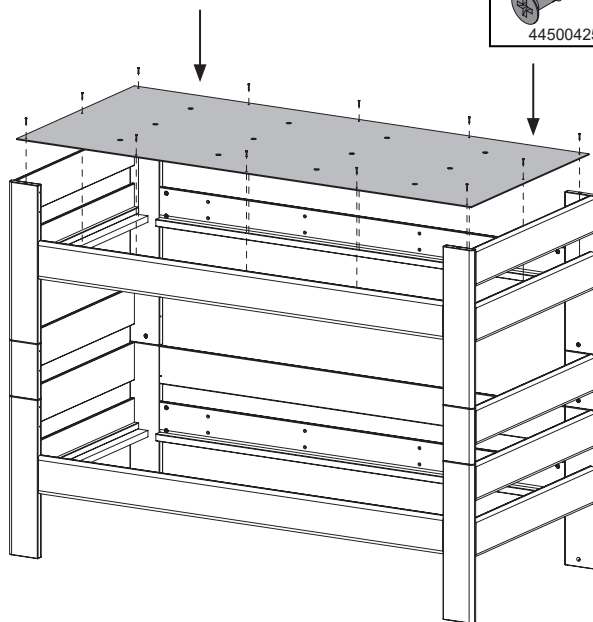
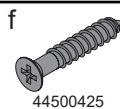

REMARQUE

- Monter la tablette intermédiaire uniquement sur le lit supérieur.

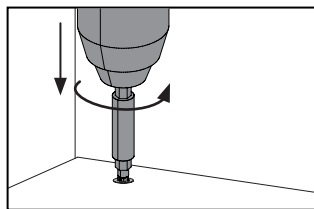

9.4 Serrer les vis d'assemblage

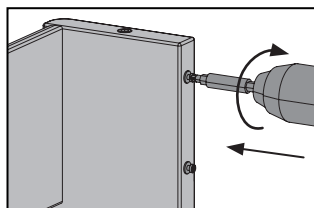
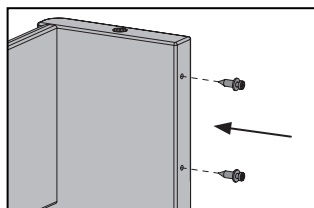
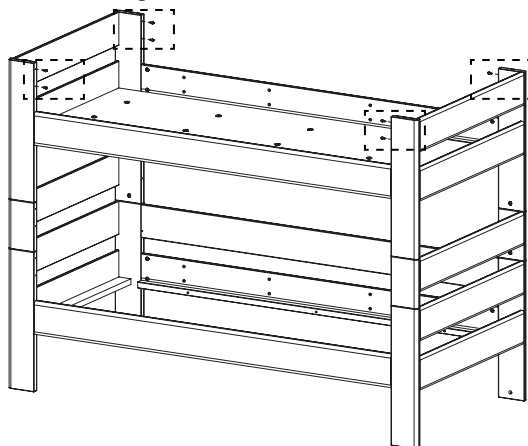
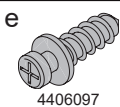

10. Echelle

10.1 Serrer les vis d'assemblage

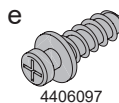

Hauteur de matelas maximum

ATTENTION

- La hauteur maximum de matelas ne doit en aucun cas être dépassée !

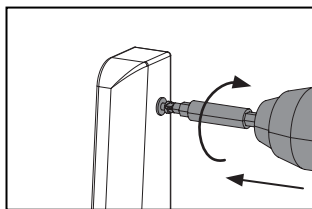
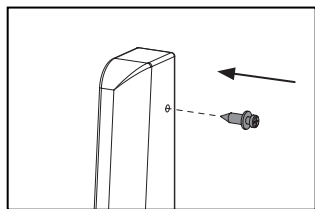
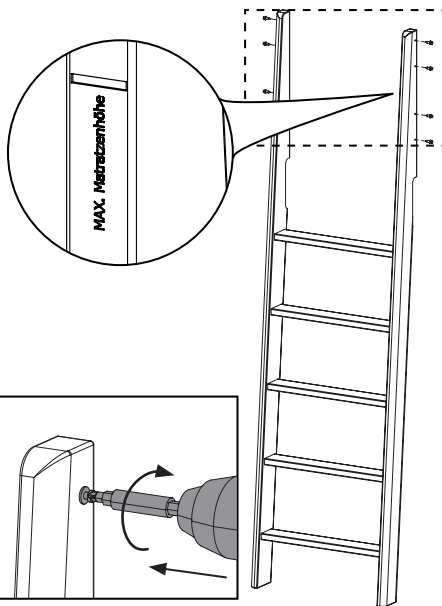

10.2 Monter l'escabeau

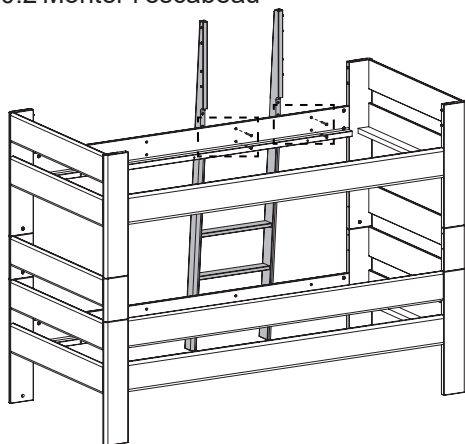

REMARQUE

- L'escabeau peut être fixé librement aux 4 positions prédécoupées.

ATTENTION

- Utiliser impérativement une cale pour percer ! Risque d'arrachage !

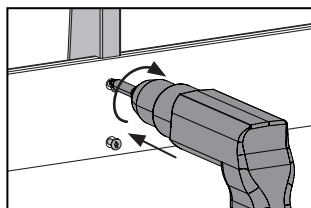
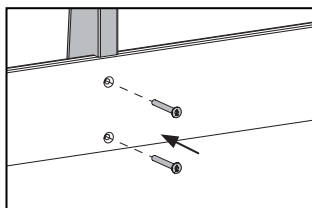
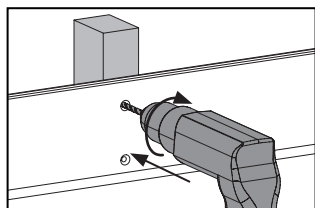

11. Rambarde avec escabeau

11.1 Monter les planches de rambarde

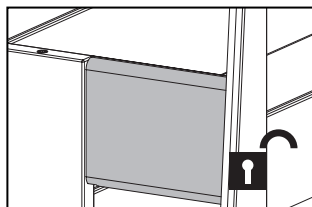
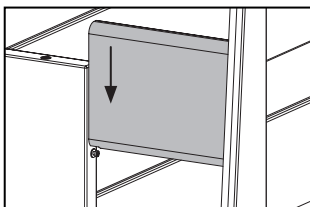
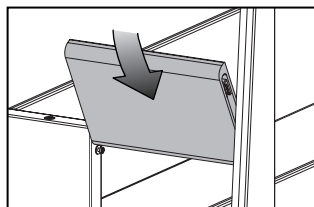
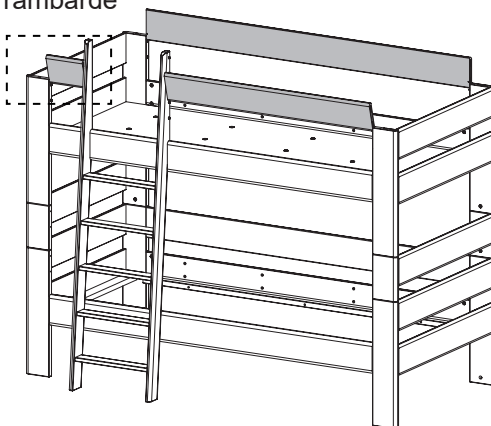

11.2 Fixer la planche de rambarde

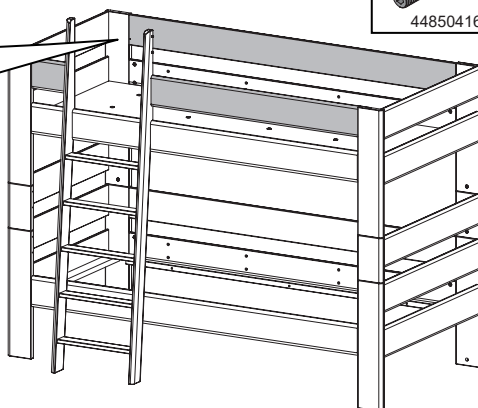
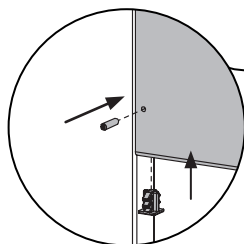

ATTENTION

- Serrer la vis sans tête à fleur !

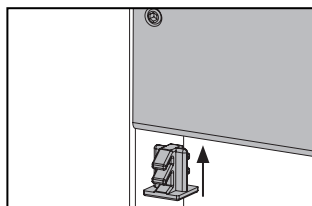
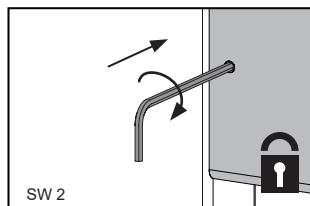
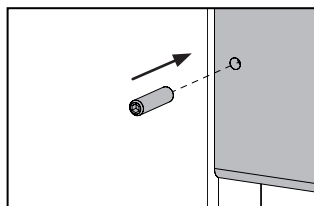

11.3 Visser les chevilles en acier

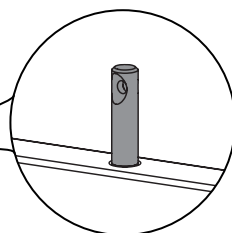
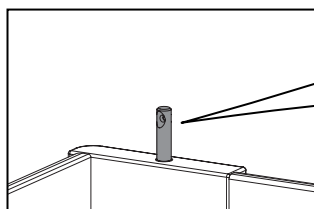
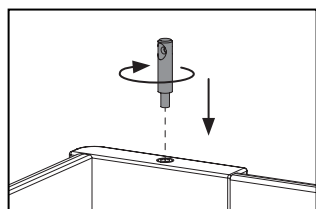
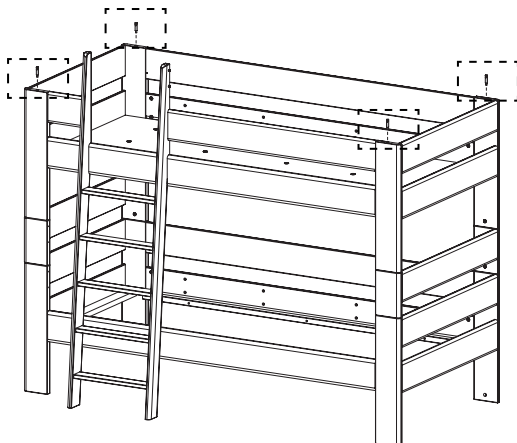

11.4 Monter les ferrures sur l'élément à poser du lit

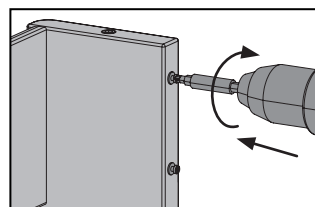
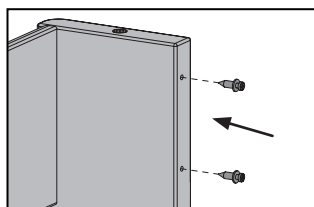
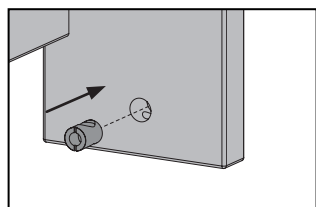
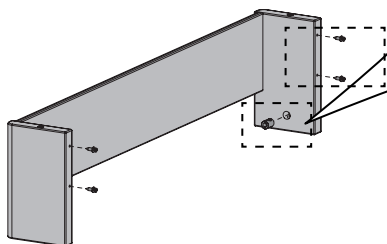
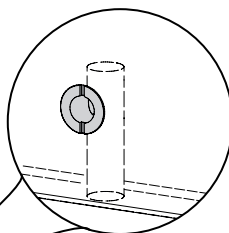
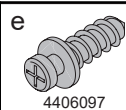
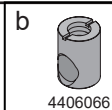

11.5 Monter l'élément à poser du lit

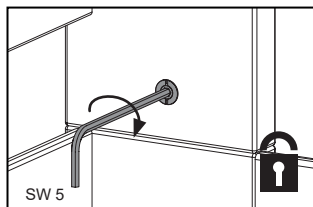
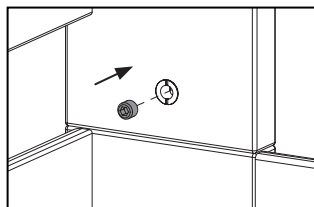
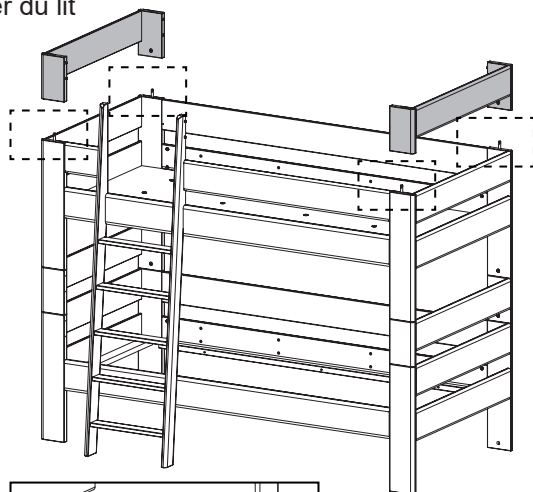
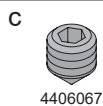

11.6 Monter les planches de rambarde

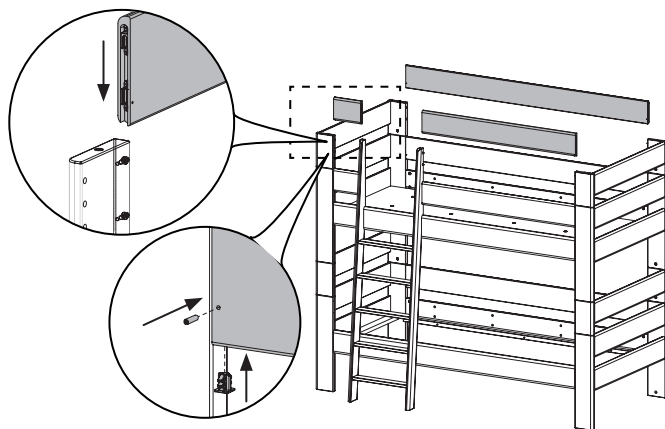

ATTENTION

- Serrer la vis sans tête à fleur !

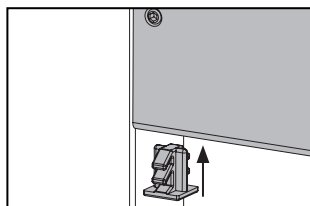
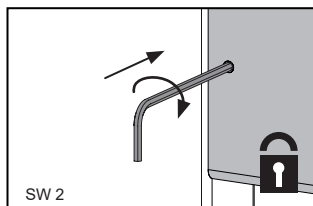
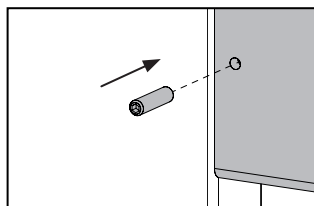

12. Vis

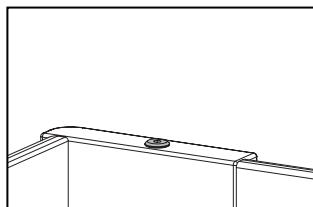
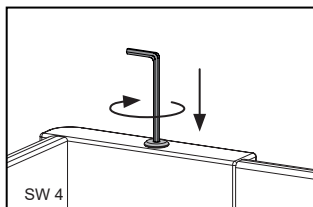
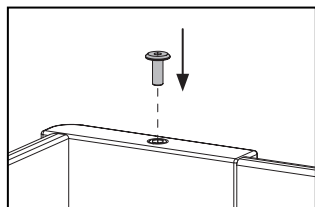
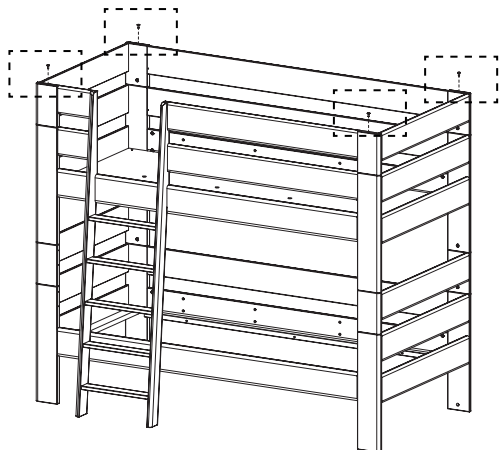
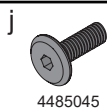

Uniquement pour lit caverne :

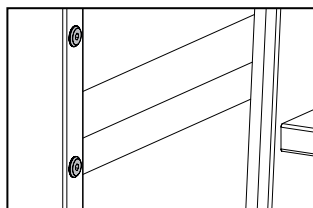
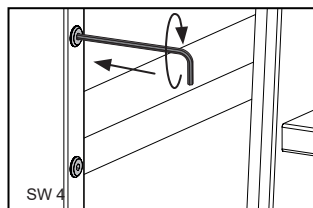
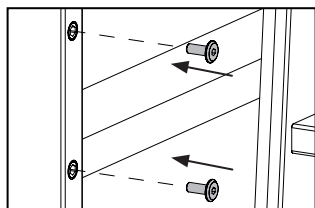
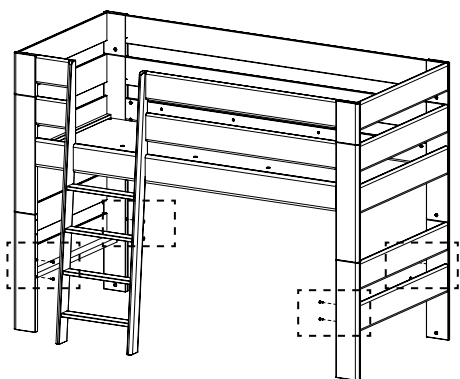

13. Bouchon

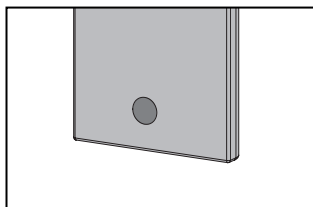
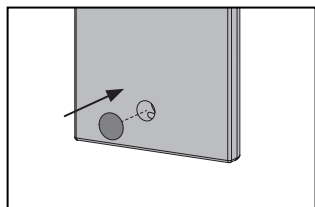
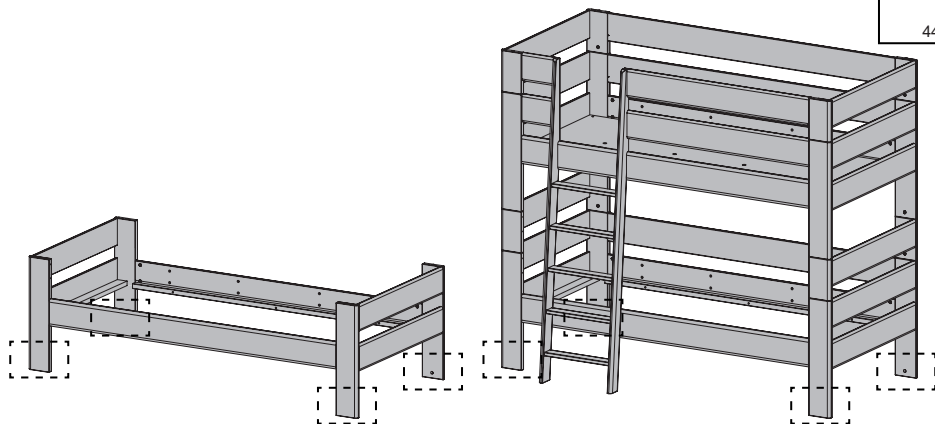

TEAM 7

TEAM 7 Natürlich Wohnen GmbH

Braunauer Str. 26

4910 Ried im Innkreis, AUSTRIA

Installation Hotline: +43/7752-977321

www.team7-home.com

Sous réserve de modification, d'erreur et de coquille

Droit d'auteur

L'œuvre et toutes ses parties sont protégées par le droit d'auteur. Toute utilisation, en dehors des limites strictes prévues par la loi sur le droit d'auteur, faite sans le consentement de l'entreprise TEAM 7 GmbH, est illicite et passible de poursuites judiciaires. Ladite clause s'applique notamment à la reproduction, au microfilmage, ainsi qu'à la sauvegarde et au traitement par voie électronique.

TEAM 7



NR 00034

DIN EN 1725:1998-02

DIN EN 747-1:2012+A1:2015

Istruzioni per il montaggio

Kids

Sistema di letto

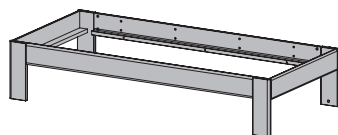

Letto singolo base

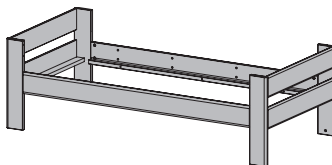

Letto singolo senza spondina

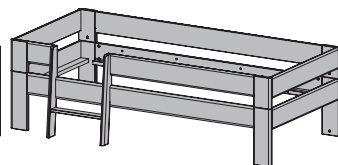

Letto singolo con spondina

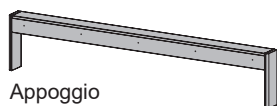

Appoggio

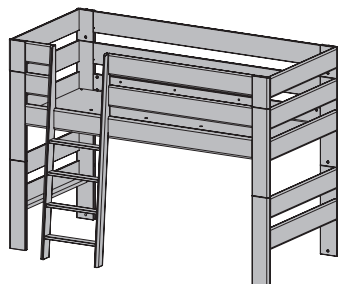

Letto a soppalco

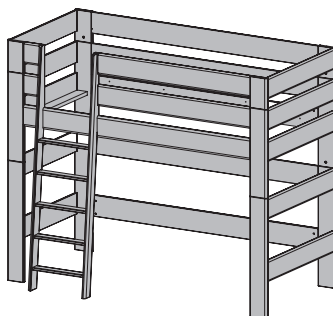

Letto sopraelevato

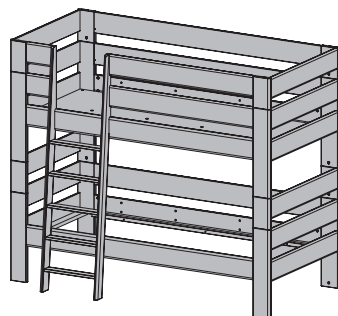

Letto a castello

IT

022023
TD280811B

Dopo il montaggio da
conservare per i nostri
clienti!

! CLIMA DELL'AMBIENTE

- Il clima ambiente ideale per persone, piante e mobili in legno naturale è:

**Umidità atmosferica rel. 40 - 60% e una
Temperatura ambiente: fra 18 e 23° Celsius.**

- In caso di superamento in eccesso o in difetto di questi valori per lungo tempo, si verificano ritiri o rigonfiamenti. In seguito possono verificarsi svirgolamento, crepe, scollamento di fughe e irruvidimento delle superfici.

! MANUTENZIONE

- Per le istruzioni di manutenzione (cura di pannelli in legno naturale, pelle, stoffa, Stricktex, pietra, vetro, Metallo, ceramica feltro e piani di lavoro) consultare il sito web di TEAM 7.

- Troverete importanti caratteristiche dei mobili in legno naturale TEAM 7 anche nel nostro pass assistenza e qualità qui:

<https://www.team7-home.com/at/de/service/service-und-guetepass/>



! DOCUMENTAZIONE

- Conservare accuratamente tutta la documentazione relativa all'acquisto di questo mobile, anche oltre la garanzia di due anni obbligatoria per legge.
- Quando si richiedono parti di ricambio o di integrazione, la documentazione d'acquisto facilita la ricerca di informazioni precise sul prodotto acquistato.
- In caso di danni ai mobili causati dal trasporto, è assolutamente necessario produrre foto della parte danneggiata nell'imballaggio originale.

Indice

Pagina

1. NOTE TECNICHE IMPORTANTI PER LA SICUREZZA	3
2. Attrezzi	4
3. Ferramenta	4
4. Letto singolo	4 - 5
5. Appoggio	5
6. Rete a doghe	6
7. Sponda	6 - 7
8. Sopralzo	8
9. Letto superiore	9 - 10
10. Scaletta	11
11. Sponda con scaletta	12 - 14
12. Viti di copertura	15
13. Tappo di copertura	16

1. NOTE TECNICHE IMPORTANTI PER LA SICUREZZA

IMPORTANTE - LEGGERE ATTENTAMENTE E CONSERVARE!

- Leggere attentamente tutta la documentazione allegata prima del montaggio e conservare le istruzioni per futuro riferimento.
- **ATTENZIONE:** i letti sopraelevati e il letto superiore dei letti a castello non sono adatti a bambini di età inferiore a 6 anni per via del rischio di lesioni dovute alla caduta.
- **AVVERTENZA:** in caso di uso improprio i letti a castello e i letti a soppalco possono rappresentare un grave pericolo di lesione per strangolamento. Gli oggetti che non sono destinati all'uso con il letto non devono essere mai fissati o agganciati a una parte del letto a castello, questo vale ad es., ma non solo, per funi, cordoncini, spaghi, ganci, cinghie e borse.
- **ATTENZIONE:** i bambini potrebbero rimanere intrappolati tra il letto e la parete. Per scongiurare il pericolo di gravi lesioni, la distanza tra lo spigolo superiore del dispositivo antiribaltamento e la parete deve essere al massimo di 75 mm oppure superiore a 230 mm
- **ATTENZIONE:** Non usare il letto a castello se una qualche sua parte è danneggiata o difettosa, strappata o mancante.
- Tutti gli elementi di collegamento devono venire perfettamente serrati al momento del montaggio e non devono allentarsi durante l'uso. Controllare regolarmente che gli elementi di collegamento siano saldi.
- Tutti i ricambi e tutti gli elementi supplementari devono essere acquistati solo presso TEAM 7.
- Seguire sempre le istruzioni e le avvertenze della Team 7.
- Dimensioni consigliate per il materasso: 2000mm x 900mm / 2000mm x 1000mm
2000mm x 1400mm
- In nessun caso si deve superare l'altezza massima del materasso!
- Per mantenere una bassa umidità dell'aria, evitando così la formazione di muffa nel letto e intorno ad esso, è necessaria una sufficiente aerazione dell'ambiente.

2. Attrezzi

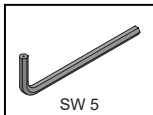
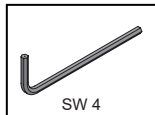
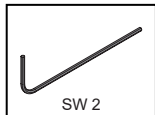
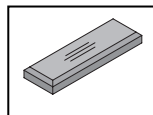
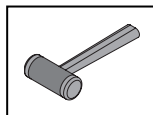
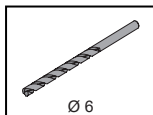
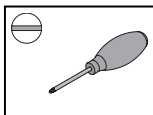
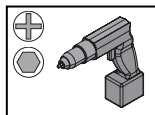

3. Ferramenta

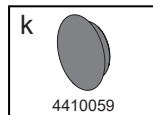
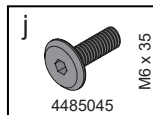
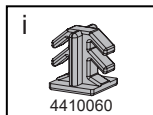
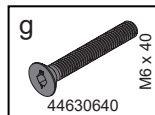
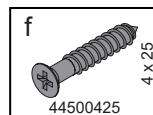
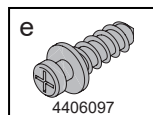
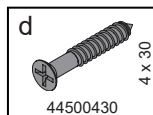
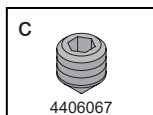
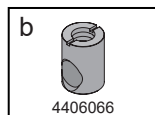
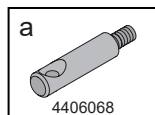

4. Letto singolo

4.1 Avvitare il tassello in acciaio

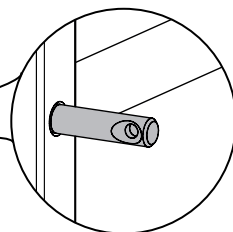
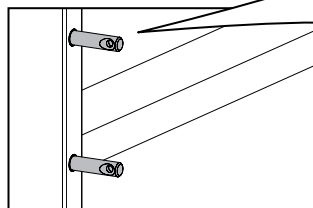
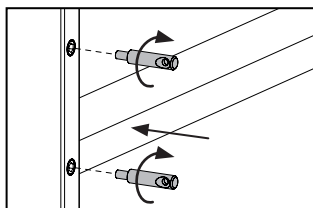
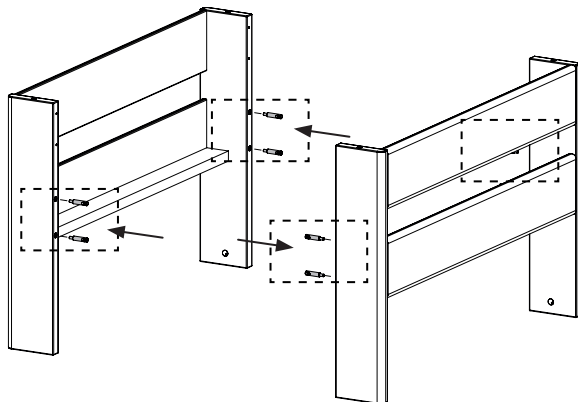
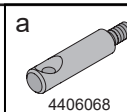

4.2 Inserire l'alloggiamento

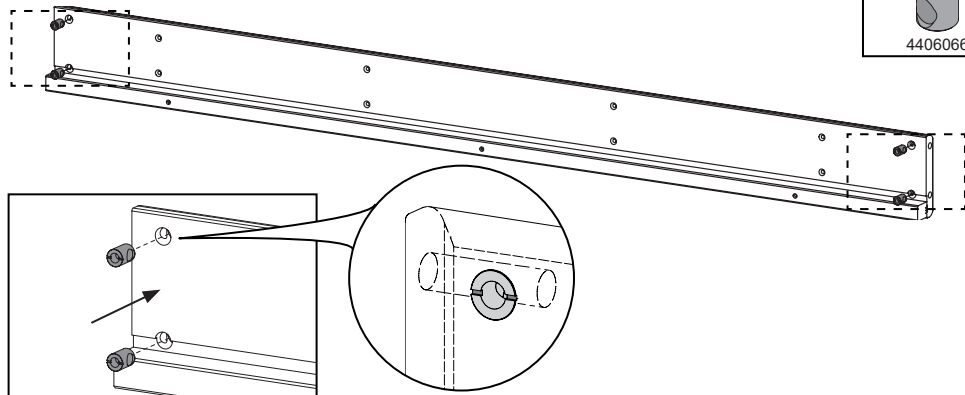
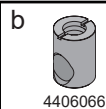

4.3 Montare i longheroni

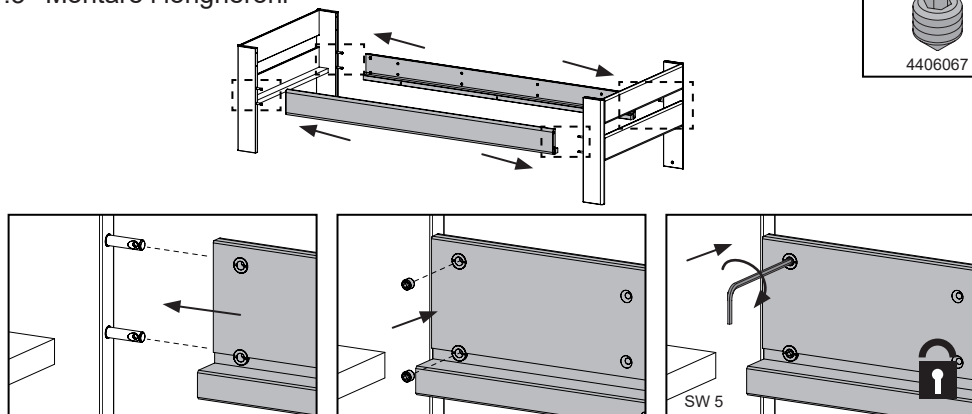
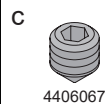

5. Opzionale: Appoggio

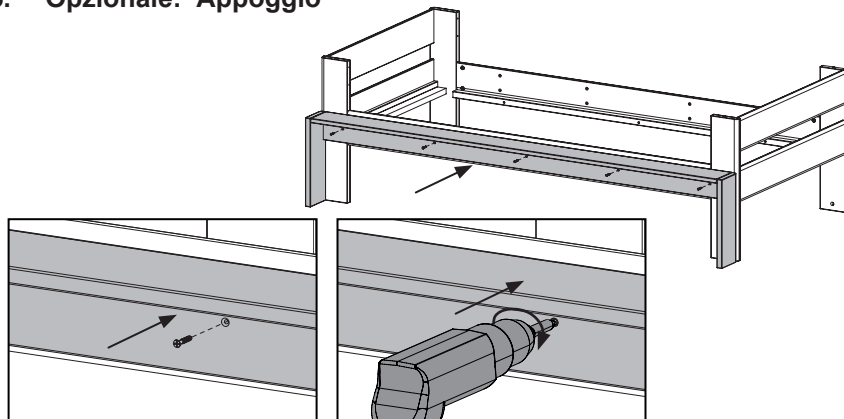
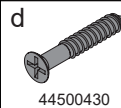

6. Rete a doghe

6.1 Inserire la rete a doghe

AVVERTENZA

- Con i letti a castello, la rete a doghe deve essere inserita prima dell'impilamento

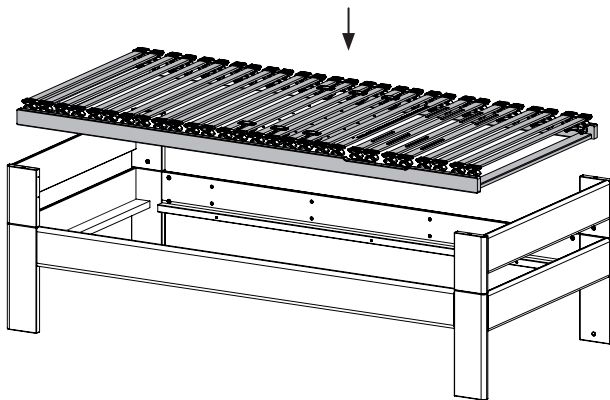

6.2 Inserire la barra distanziatrice

AVVERTENZA

- A seconda della lunghezza della rete a doghe, è necessario inserire 1 - 2 barre distanziatrici per evitare che la rete a doghe si sposti.

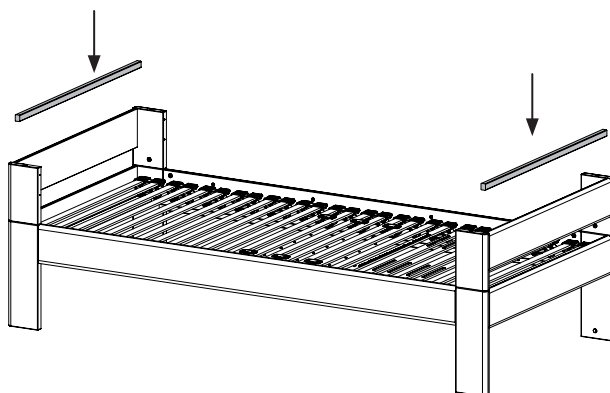

7. Sponda

7.1 Avvitare le viti di collegamento

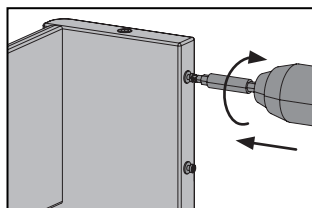
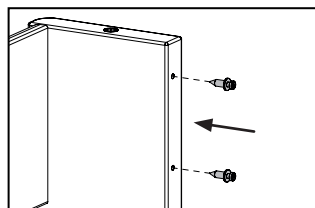
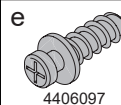

7.2 Montare la spondina

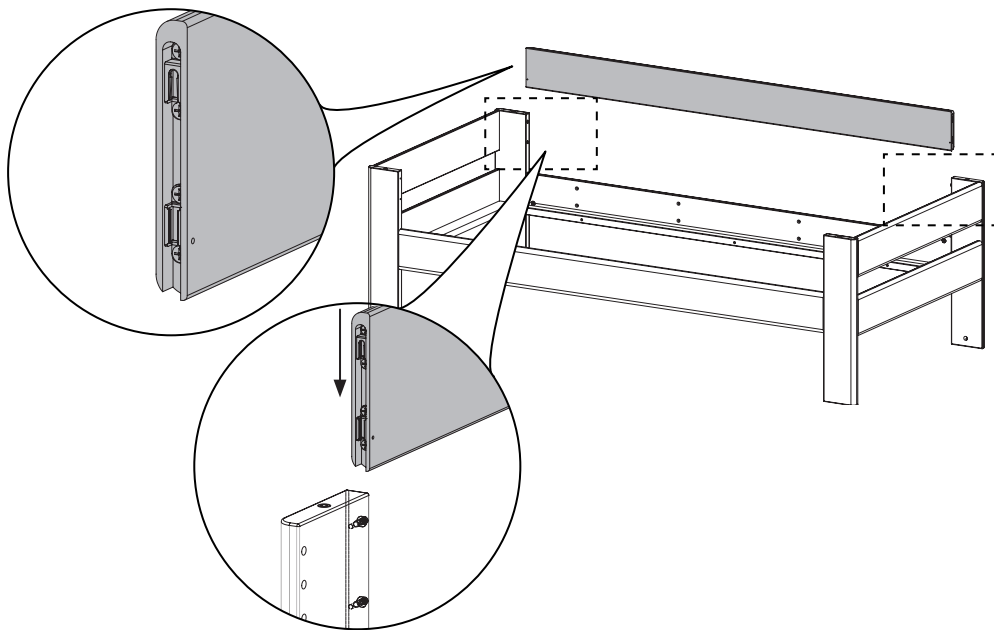

7.3 Fissare la spondina

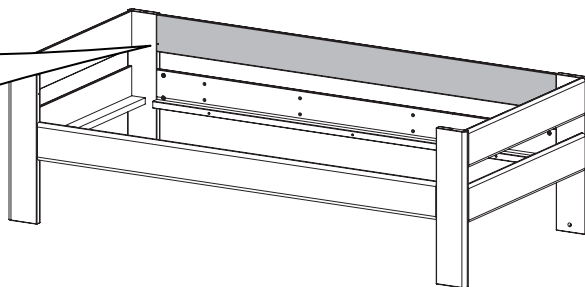
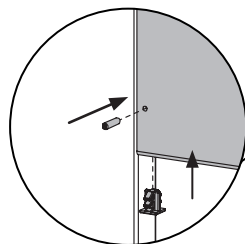
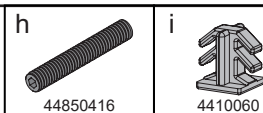

ATTENZIONE

- Avvitare la vite senza testa a filo!

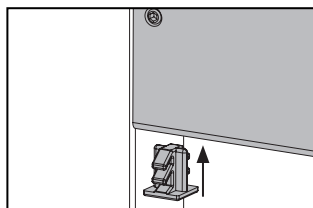
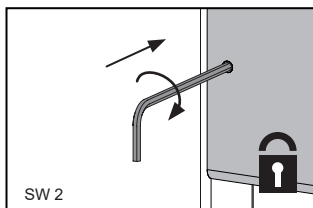
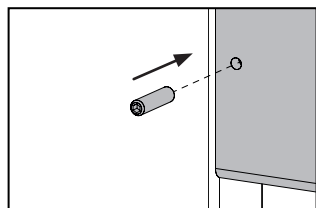

8. Sopralzo

8.1 Avvitare il tassello in acciaio

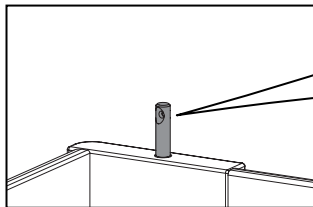
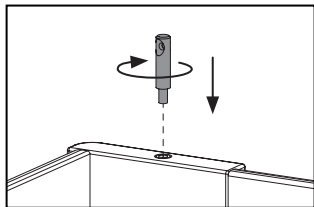
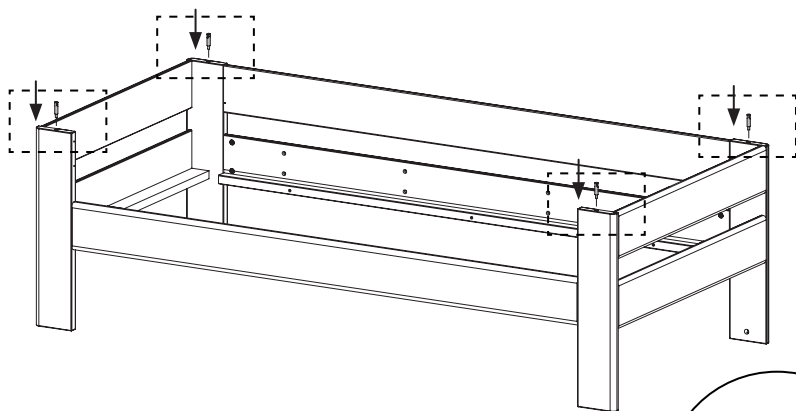
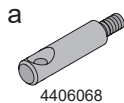

8.2 Montare l'estensione del letto

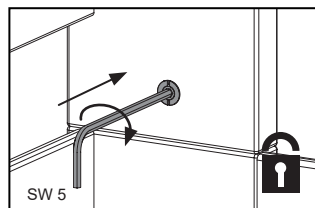
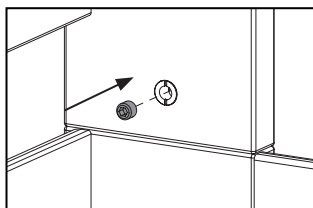
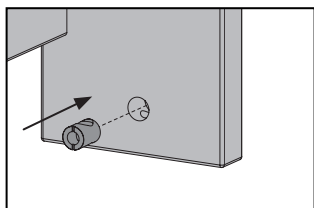
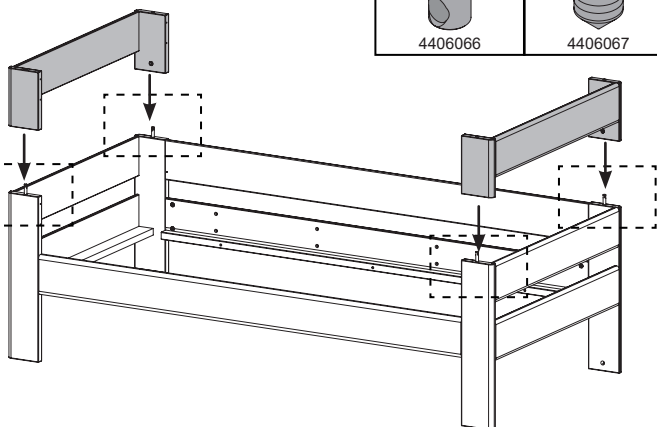
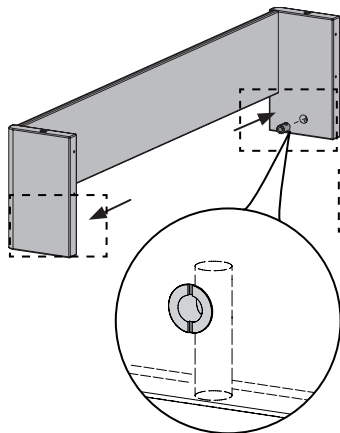
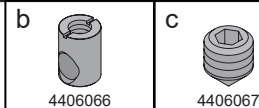

9. Letto superiore

9.1 Avvitare il tassello in acciaio

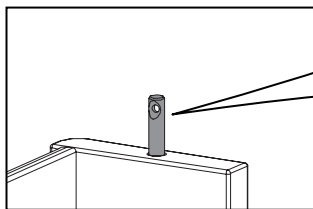
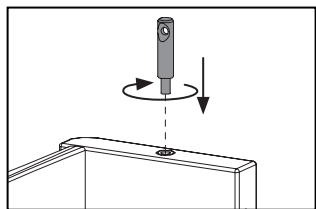
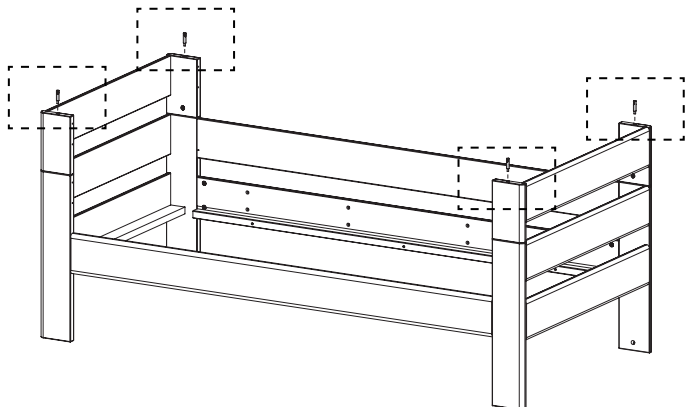

9.2 Collegare i letti

AVVERTENZA

- Per il letto superiore ripetere il passaggio 4

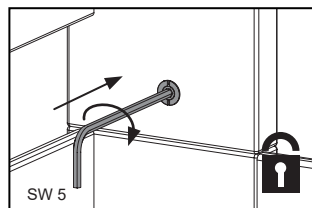
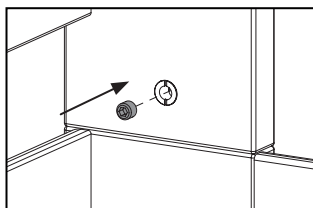
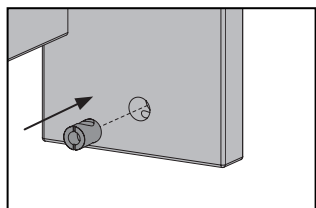
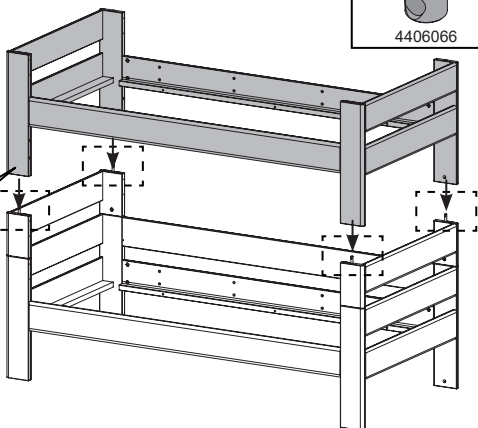
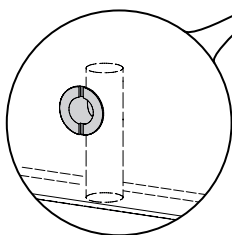
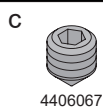
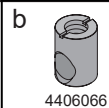

9.3 Montare il ripiano intermedio

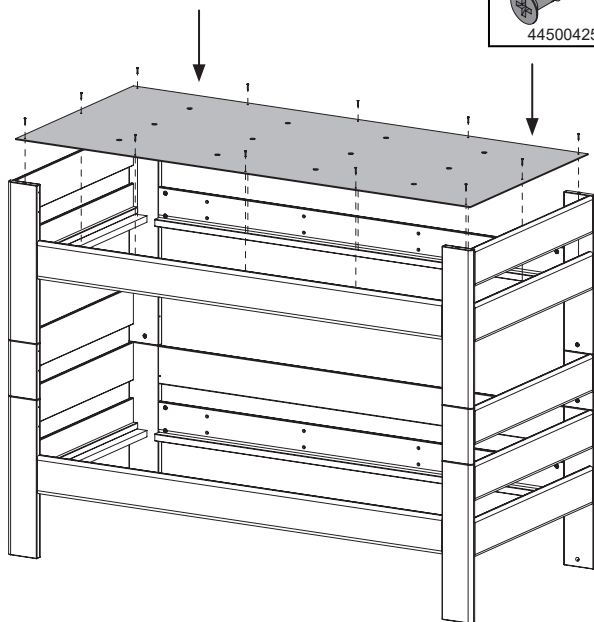
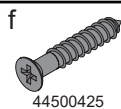

AVVERTENZA

- Il ripiano intermedio viene montato solo con il letto superiore.

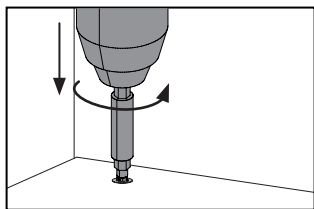

9.4 Avvitare le viti di collegamento

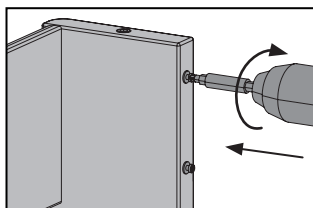
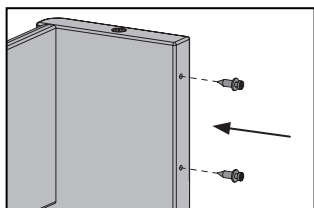
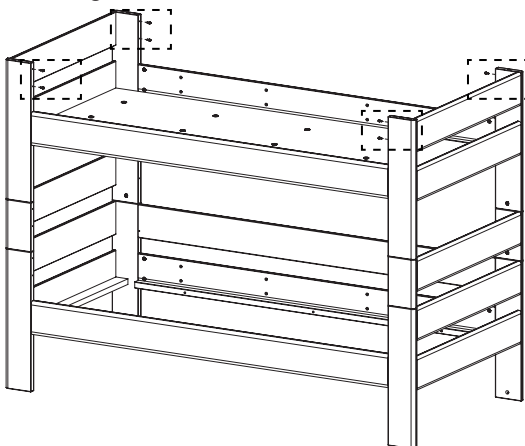
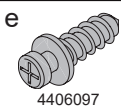

10. Scaletta

10.1 Avvitare le viti di collegamento

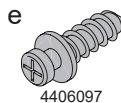

Altezza massima materasso

ATTENZIONE

- In nessun caso si deve superare l'altezza massima del materasso!

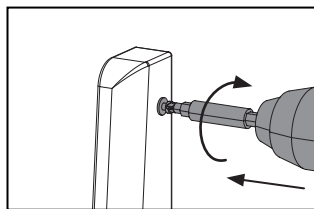
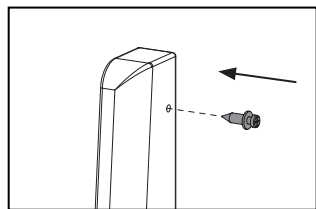
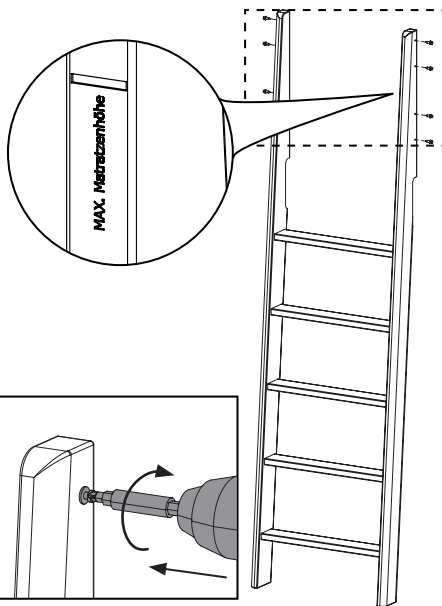

10.2 Montare la scala

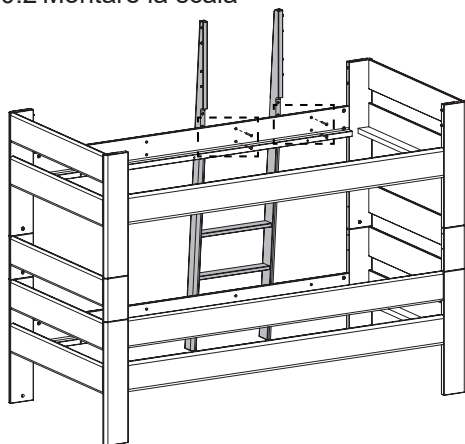

AVVERTENZA

- La scala può essere fissata liberamente sulle 4 posizioni preforate

ATTENZIONE

- Assicurarsi di usare il complemento quando si esegue un foro! Rischio di strappo!

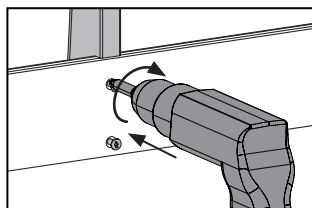
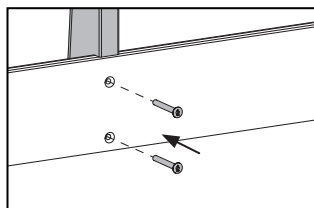
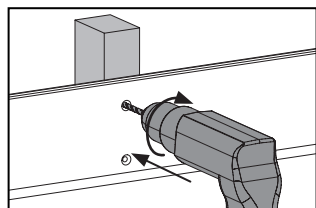

11. Sponda con scaletta

11.1 Montare le spondine

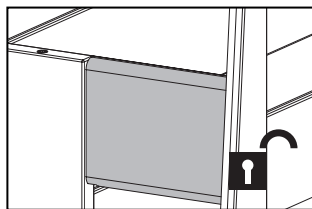
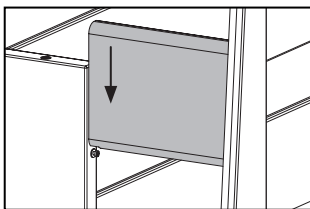
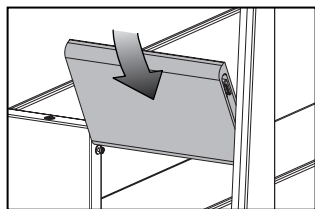
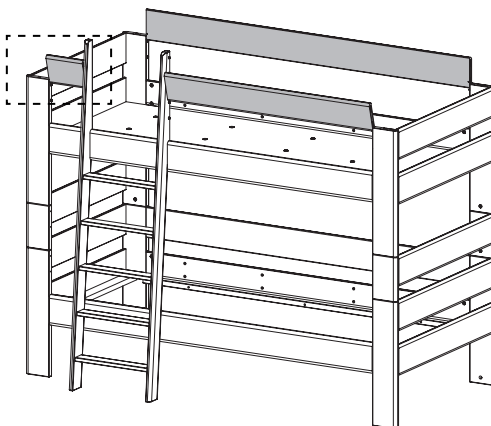

11.2 Fissare la spondina

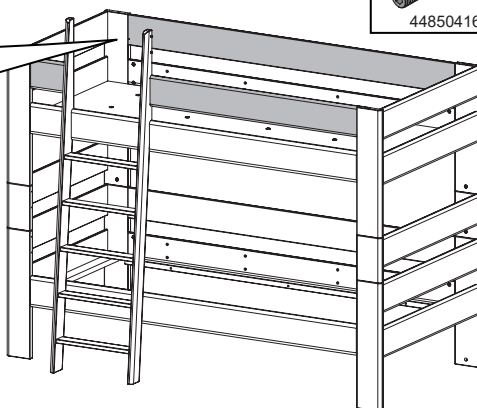
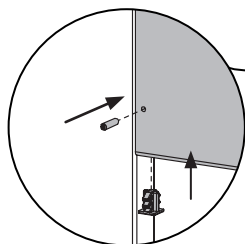

ATTENZIONE

- Avvitare la vite senza testa a filo!

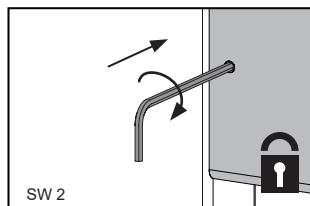
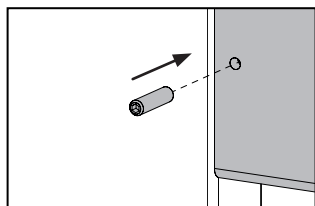

SW 2

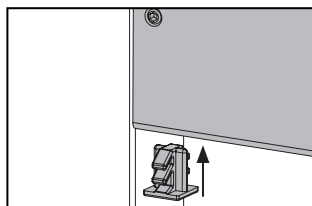

11.3 Avvitare il tassello in acciaio

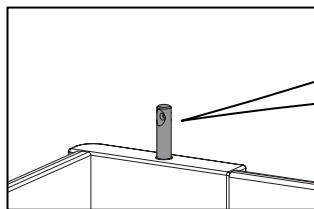
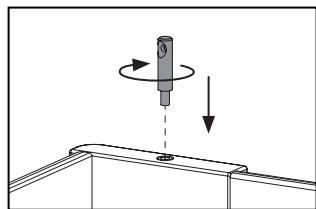
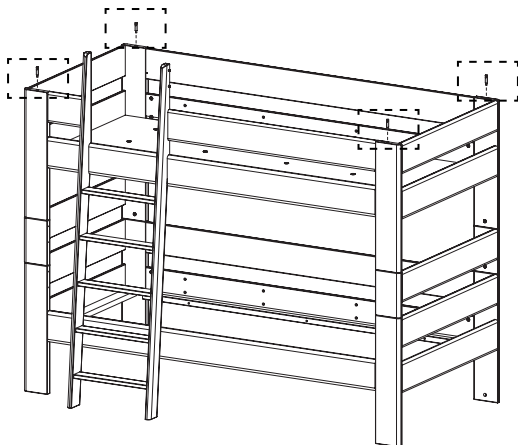
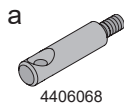

11.4 Montare la ferramenta sull'estensione del letto

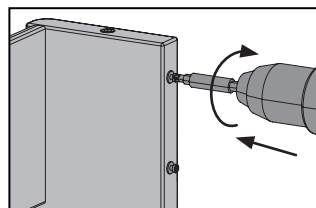
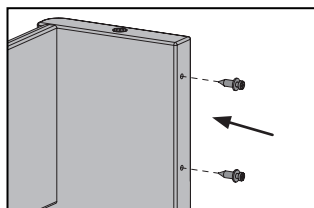
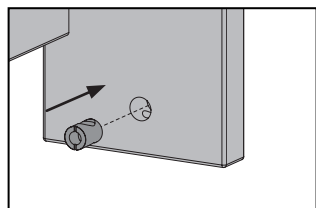
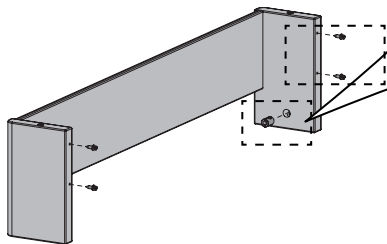
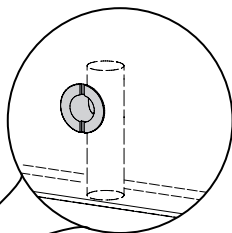
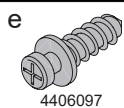
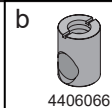

11.5 Montare l'estensione del letto

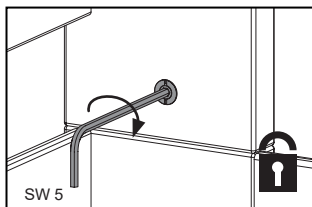
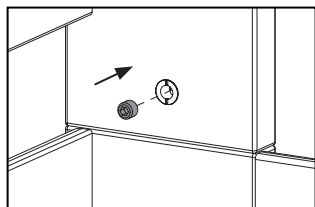
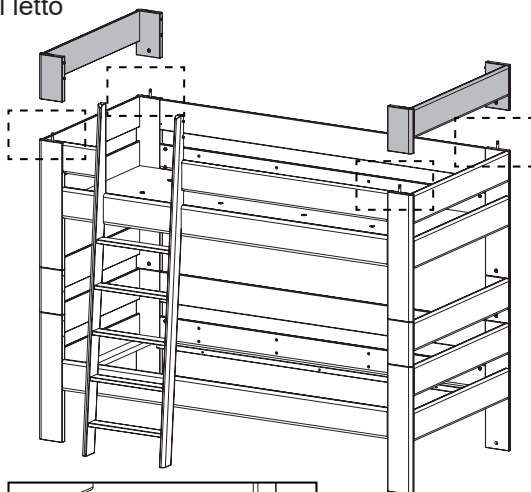
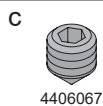

11.6 Montare le spondine

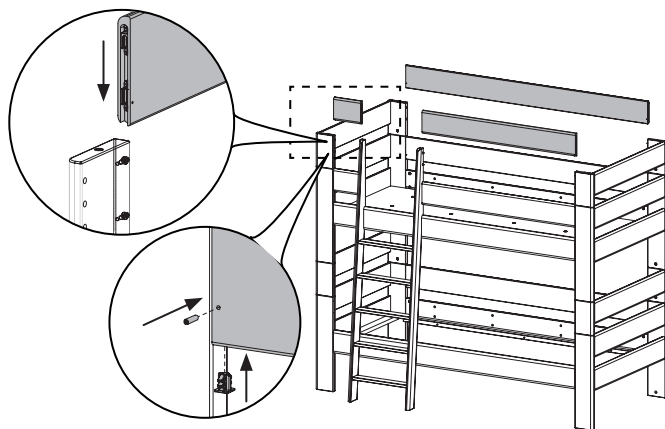

ATTENZIONE

- Avvitare la vite senza testa a filo!

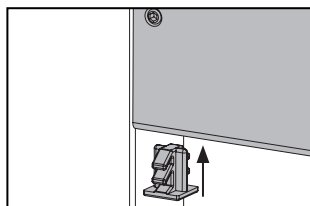
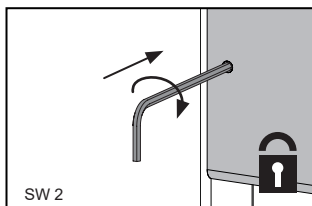
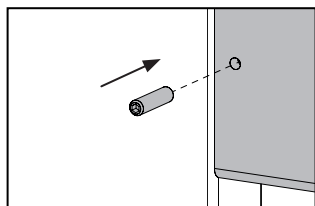

12. Viti di copertura

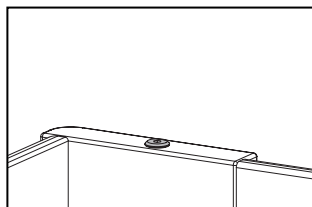
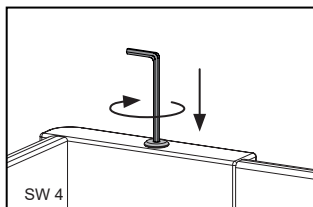
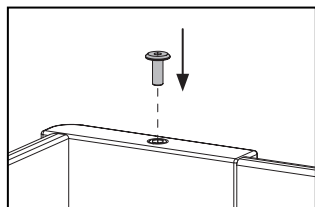
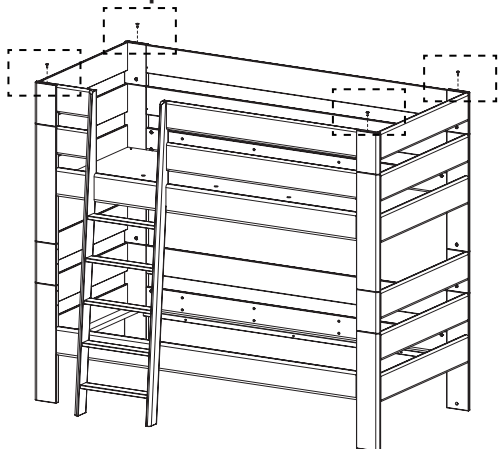

Solo con letto a soppalco:

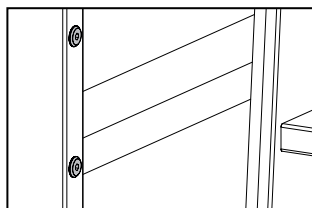
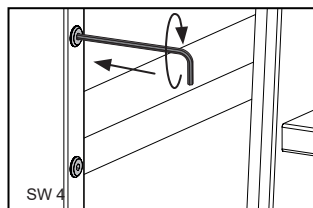
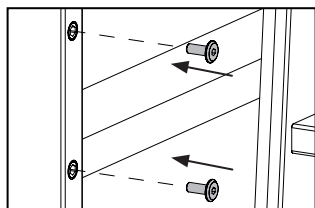
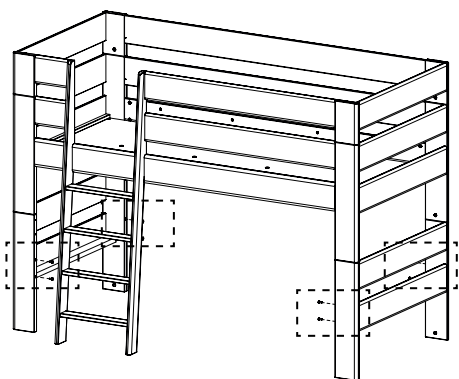

13. Tappo di copertura

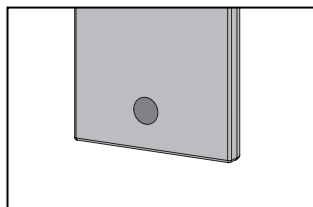
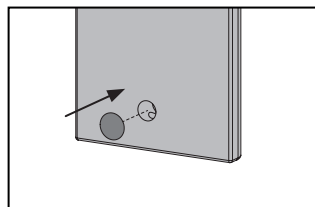
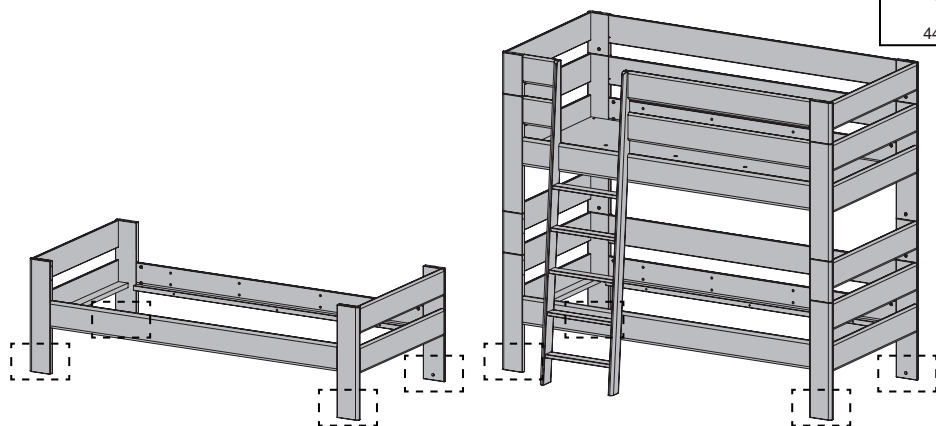

TEAM 7

TEAM 7 Natürlich Wohnen GmbH

Braunauer Str. 26

4910 Ried im Innkreis, AUSTRIA

Hotline installazione: +43/7752-977321

www.team7-home.com

Con riserva di modifiche, errori, errori di stampa e impaginazione

Diritto d'autore

La pubblicazione è tutelata da diritto d'autore in tutte le sue componenti.

Qualsiasi utilizzo che esuli dagli stretti limiti imposti dalla legge sul diritto d'autore è vietato e perseguibile ai fini di legge senza l'approvazione della ditta TEAM 7 GmbH. Questo vale in particolare per la copia, la riproduzione con microfilm e la memorizzazione ed elaborazione in sistemi elettrici.

TEAM 7



NR 00034

DIN EN 1725:1998-02

DIN EN 747-1:2012+A1:2015

Assembly Instruction

Kids

Bed system

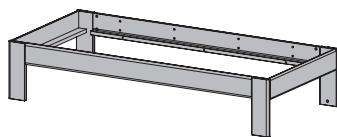

Single bed, basic

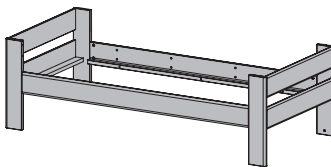

Single bed without rail

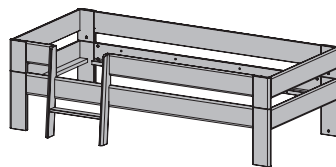

Single bed with rail

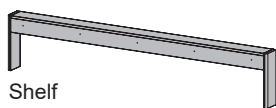

Shelf

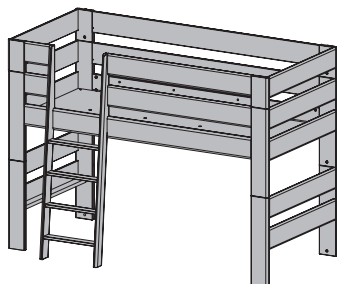

Den bed

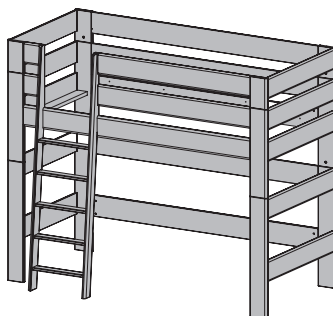

Loft bed

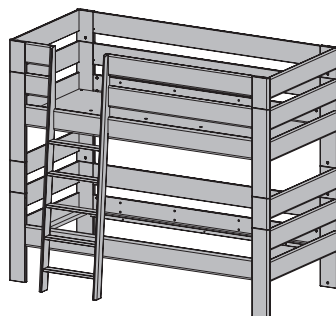

Bunk bed

GB

022023
TD280811B

After installation, keep
in a safe place for our
customers!

! INDOOR CLIMATE

- Ideal indoor climate for human beings, plants and furniture made of natural wood is:

**rel. humidity: 40 to 60% and a
Room temperature: 18° to 23° Celsius.**

- If these levels are exceeded or not reached for any prolonged period, swelling or shrinkage will occur. This may result in warping, cracking and rough surfaces.

! CARE

- Care instructions (care of natural wood, leather, fabric, Stricktex, stone, glass, felt, metal, ceramics and worktops) can be found on the TEAM 7 website.

- Major typical product properties of natural wood furniture from TEAM 7 can also be found in our service and quality certificate on:

<https://www.team7-home.com/at/de/service/service-und-guetepass/>



! DOCUMENTATION

- Keep all documents relating to the purchase of your item of furniture in a safe place, also beyond the statutory warranty period of two years.
- If you need replacement or additional parts, please refer to the purchase documentation as this will give you exact information on the product you have purchased and make the process easier.
- If your item of furniture is damaged in transit, it is imperative that you provide photographs of the damaged part while it is still in the original packaging.

Table of contents

	page
1. IMPORTANT SAFETY PRECAUTIONS	3
2. Tools	4
3. Fittings	4
4. Single bed	4 - 5
5. Shelf	5
6. Slatted frame	6
7. Rail	6 - 7
8. Top unit	8
9. Top bed	9 - 10
10. Ladder	11
11. Rail with ladder	12 - 14
12. Cover screws	15
13. Cover cap	16

1. IMPORTANT SAFETY PRECAUTIONS

IMPORTANT - READ WITH CARE AND RETAIN FOR FUTURE USE!

- Read through the enclosed documentation before starting assembly and retain
- **WARNING:** Loft beds and the top bunk bed are not suitable for children under the age of 6 as they could suffer injury from falling out of them.
- **WARNING:** Used improperly, bunk beds can present a serious risk of injury from strangulation. Objects not intended for use with the bed must never be attached to or suspended from any part of the bunk bed. This applies, for example, to items, such as ropes, cords, strings, hooks, belts and bags.
- **WARNING:** Children can become stuck between the bed and the wall. To avoid serious injury, the distance between the top edge of the drop guard and the wall must not exceed 75 mm or it must be more than 230 mm.
- **WARNING:** The bunk bed must not be used if parts are damaged or defective, frayed or missing.
- All connecting elements must be securely tightened during installation and must not be undone when in use. All connecting elements must be checked regularly to ensure they are secure.
- All spare parts and additional attachments must be purchased exclusively through TEAM 7.
- Always follow the instructions and advice provided by Team 7.
- Recommended mattress size(s): 2000mm x 900mm / 2000mm x 1000mm
2000mm x 1400mm
- The mattress height must not exceed the maximum permitted!
- Sufficient ventilation must be ensured in the bedroom to minimize humidity and avoid mold in and around the bed.

2. Tools

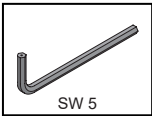
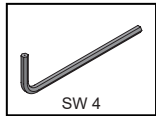
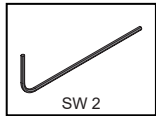
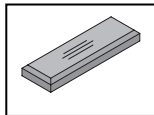
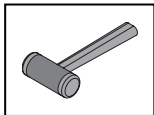
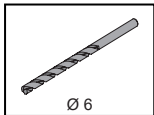
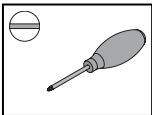
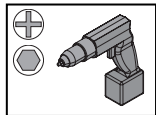

3. Fittings

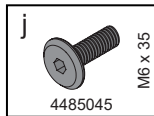
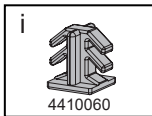
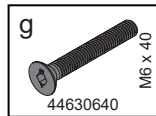
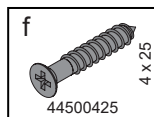
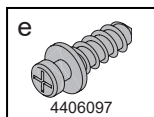
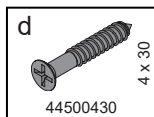
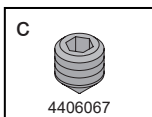
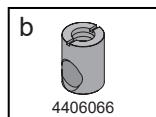
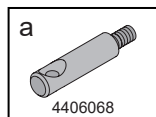

4. Single bed

4.1 Screwing in steel dowel

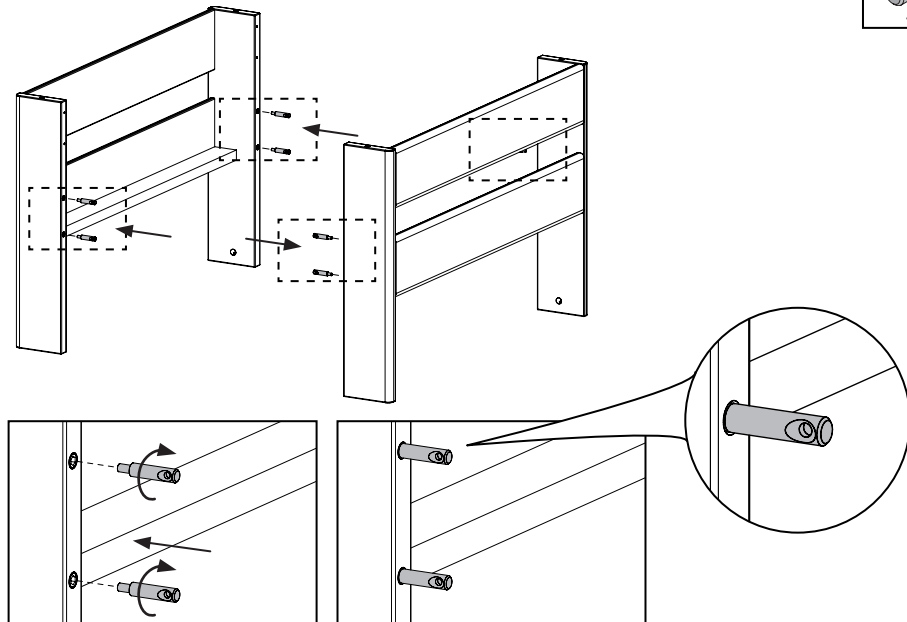

4.2 Fitting housing

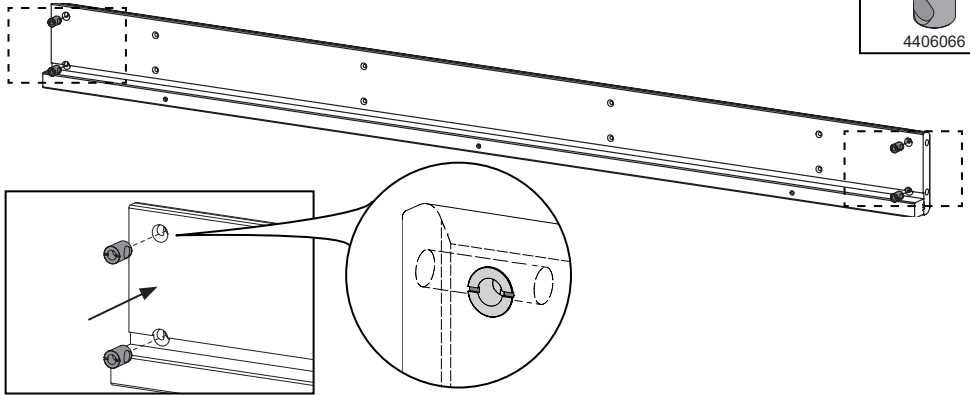
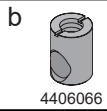

4.3 Fit bed sides

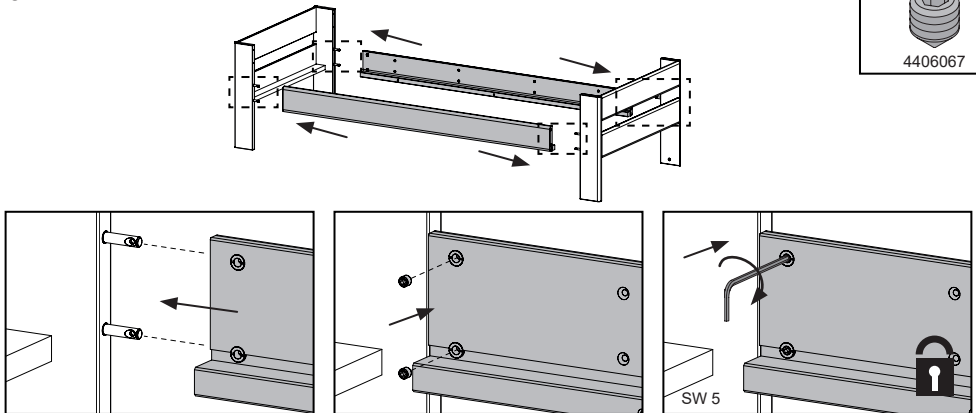
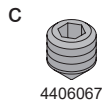

5. Optional: Shelf

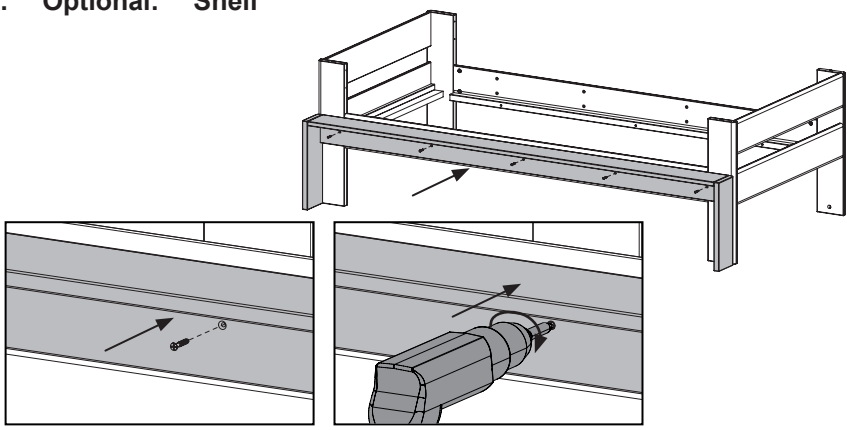
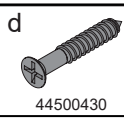

6. Slatted frame

6.1 Fitting slatted frame

NOTICE

- With bunk beds, the slatted frame must be fitted before placing one bed on top of the other.

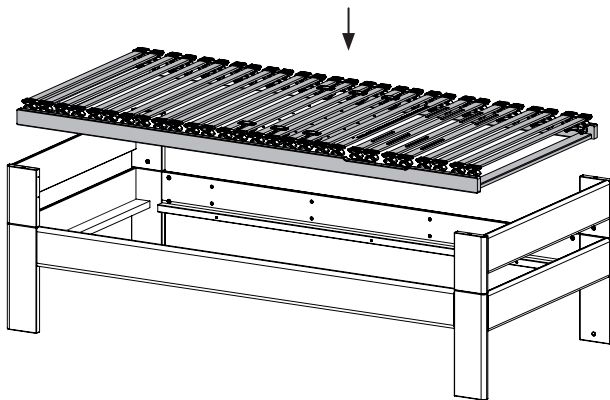

6.2 Fitting spacer strip

NOTICE

- Depending on the length of the slatted frame, 1 - 2 spacer strips must be inserted to prevent it from moving out of place.

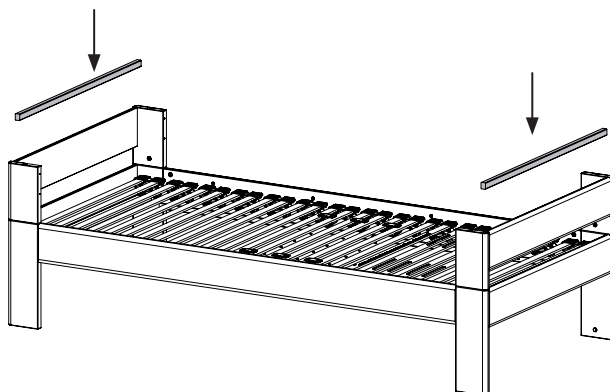

7. Rail

7.1 Screwing in connecting screws

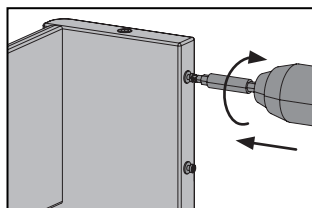
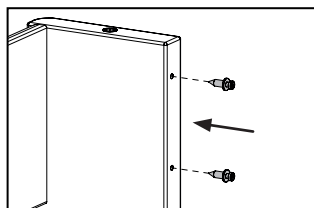
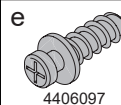

7.2 Fitting rail board

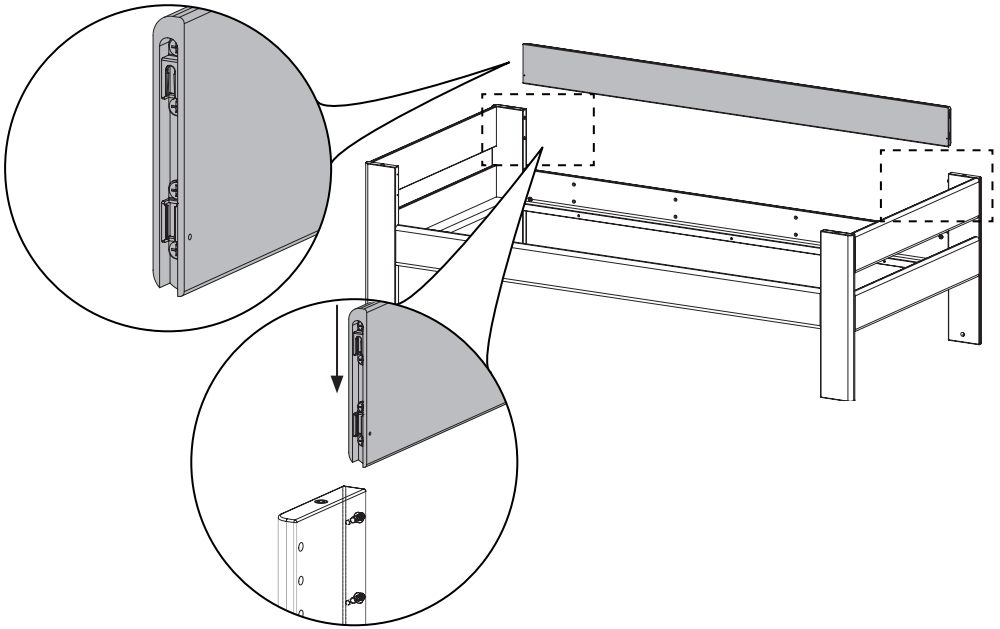

7.3 Fixing rail board in place

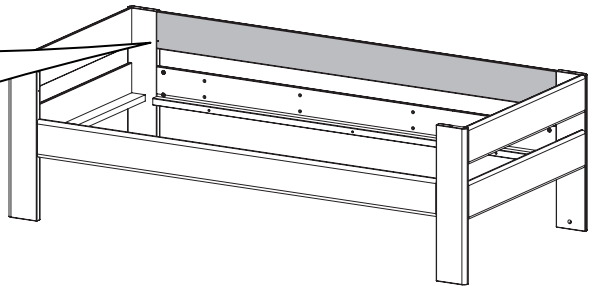
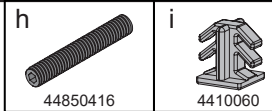
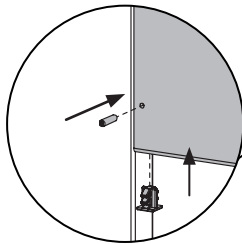

IMPORTANT

- Drive in grub screw to leave it flush with surface!

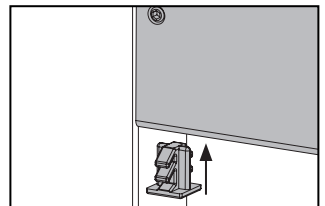
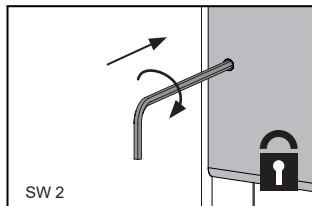
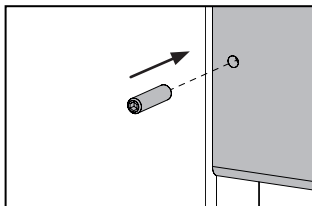

8. Top unit

8.1 Screwing in steel dowel

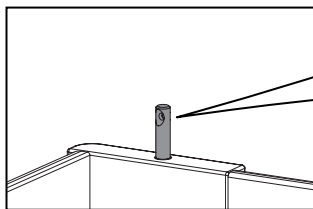
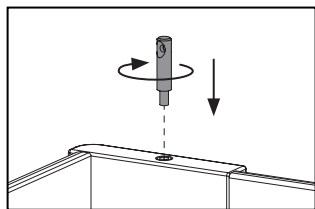
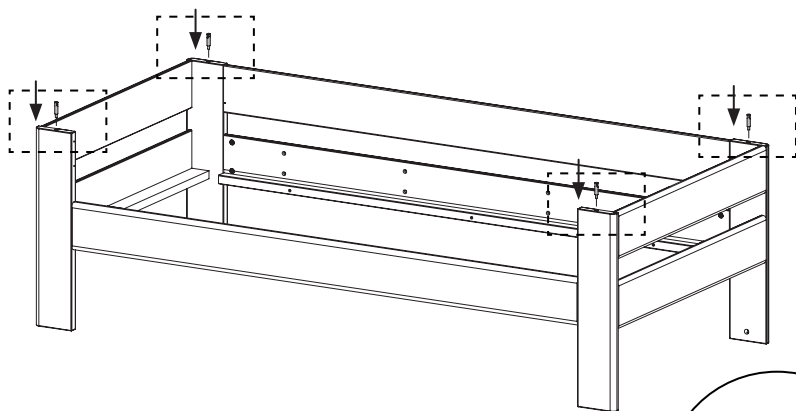
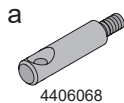

8.2 Fitting top bed

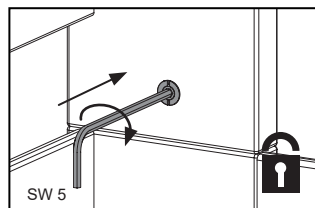
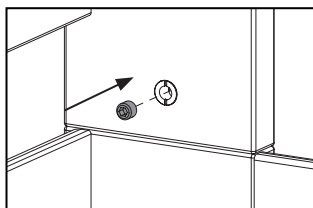
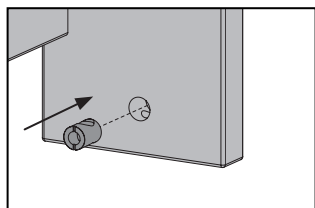
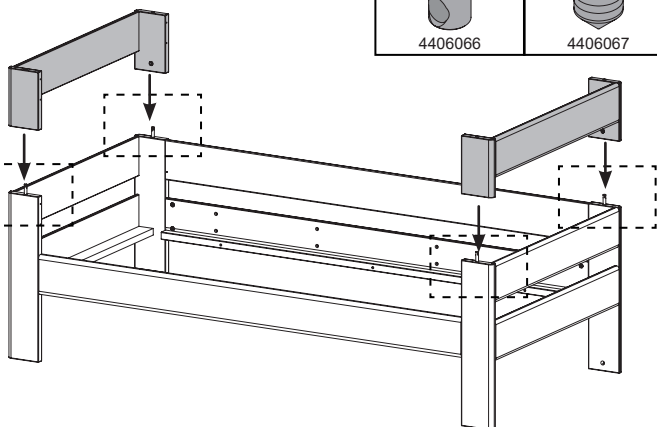
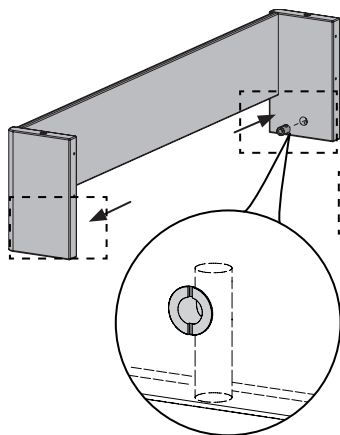
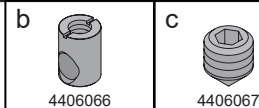

9. Top bed

9.1 Screwing in steel dowel

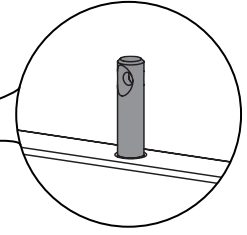
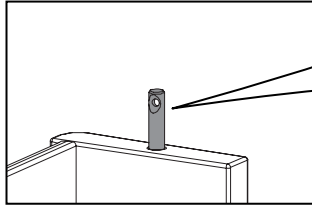
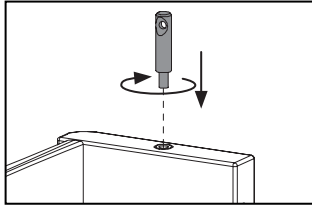
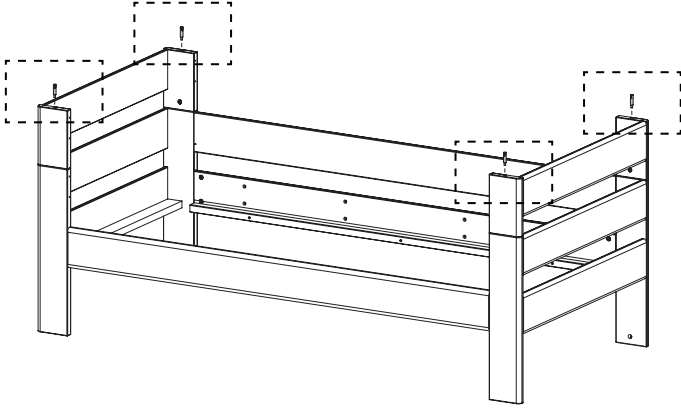
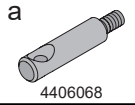

9.2 Connecting beds

NOTICE

- Repeating step 4 for top bed

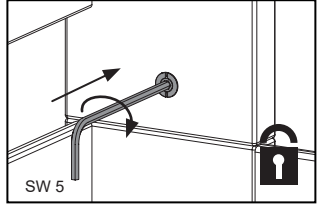
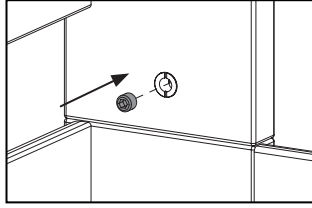
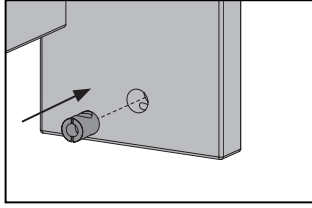
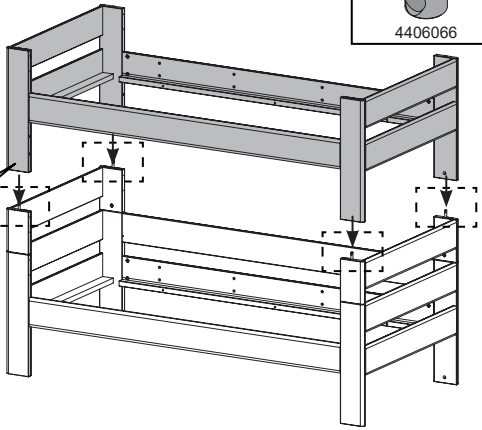
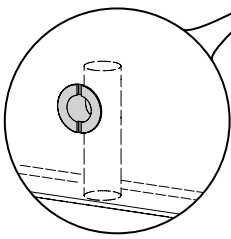
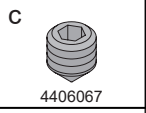
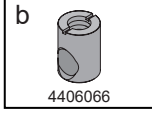

9.3 Fitting intermediate shelf

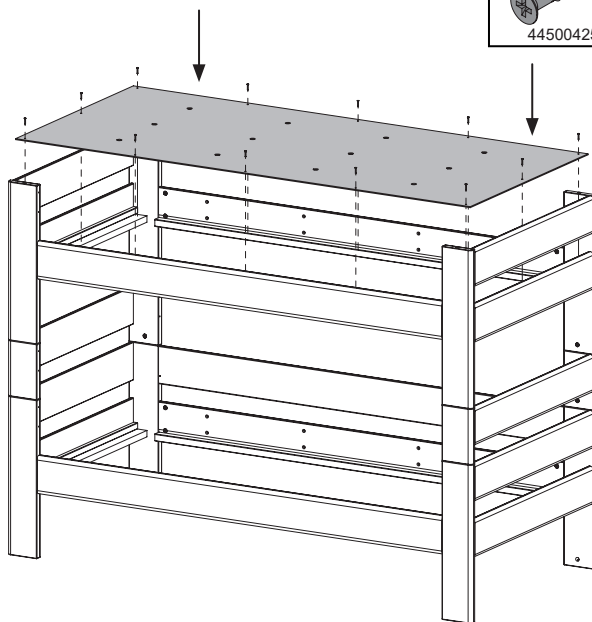
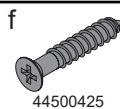

NOTICE

- Intermediate panel only fitted for top bed.

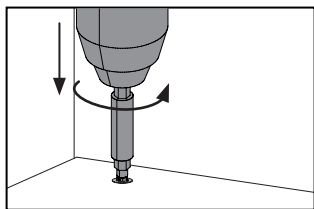

9.4 Screwing in connecting screws

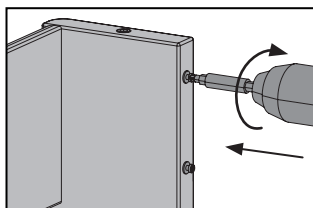
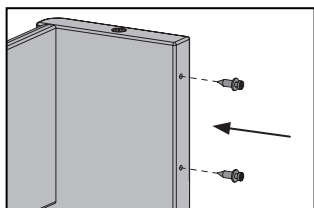
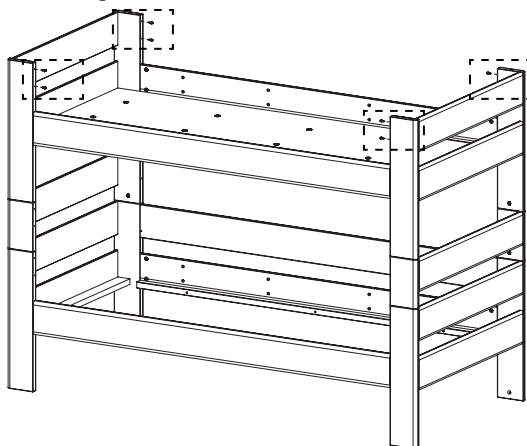
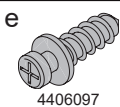

10. Ladder

10.1 Screwing in connecting screws

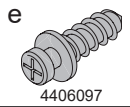

Maximum mattress height

IMPORTANT

- The mattress height must not exceed the maximum permitted!

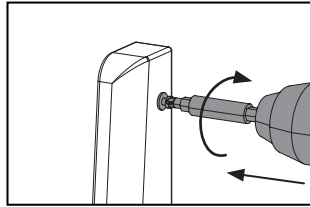
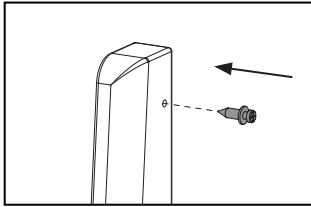
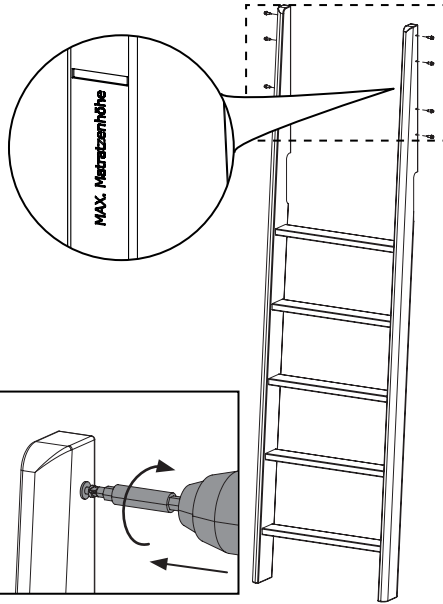

10.2 Fitting ladder

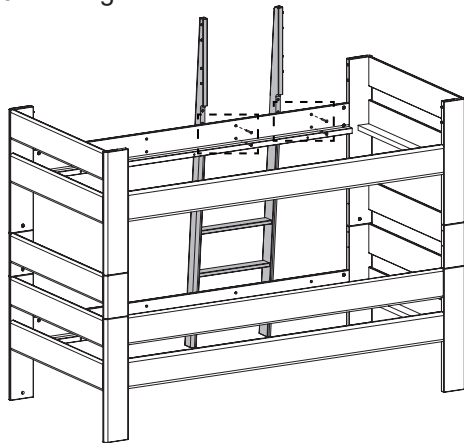

NOTICE

- The ladder can be fitted at any of the 4 pre-marked positions

IMPORTANT

- When drilling through, always include an allowance! Risk of connection tearing out!

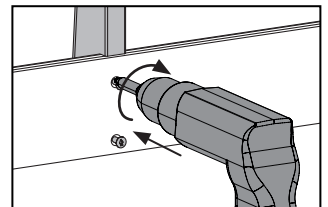
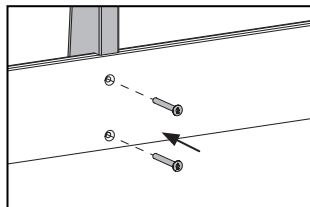
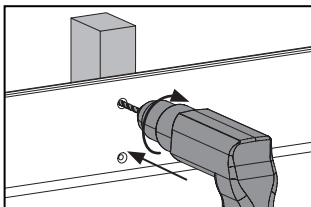

11. Rail with ladder

11.1 Fitting rail boards

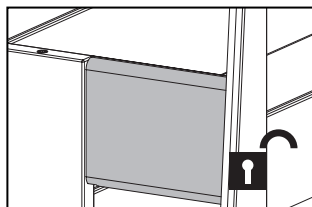
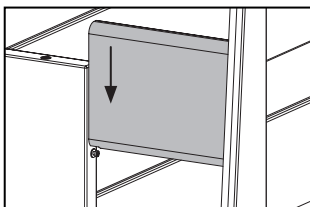
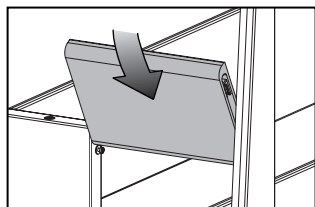
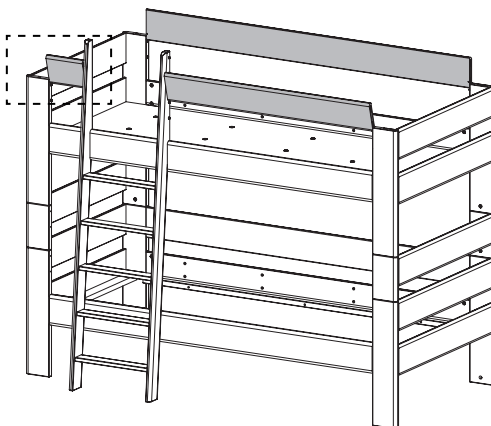

11.2 Fixing rail board in place

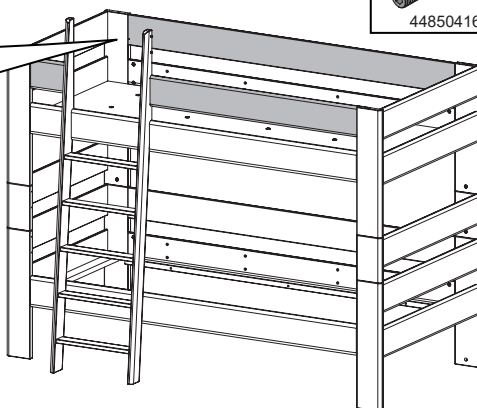
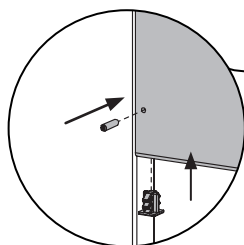

⚠ IMPORTANT

- Drive in grub screw to leave it flush with surface!

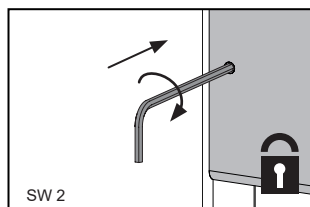
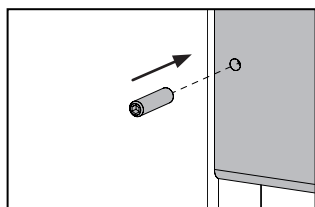

SW 2

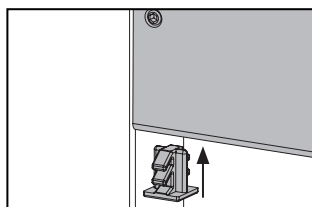

11.3 Screwing in steel dowel

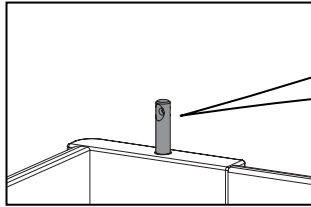
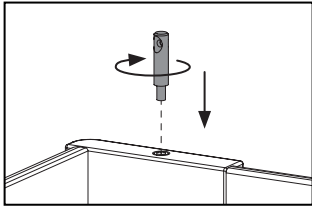
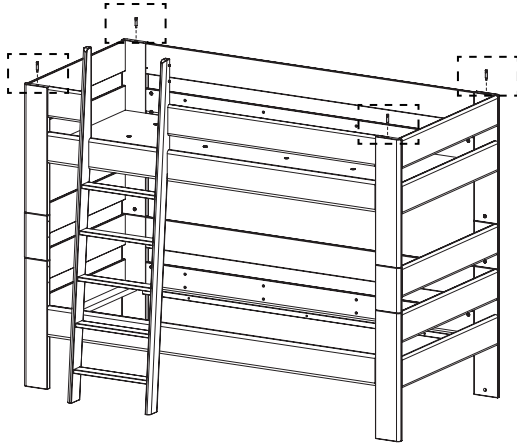
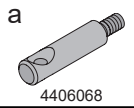

11.4 Mounting fittings to top bed

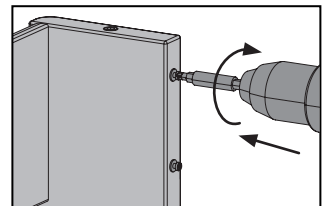
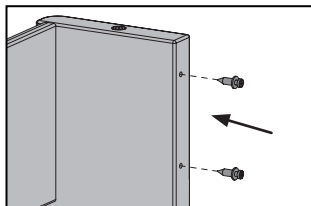
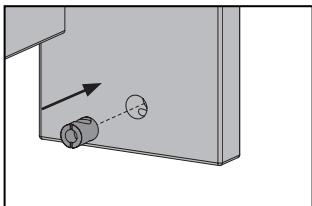
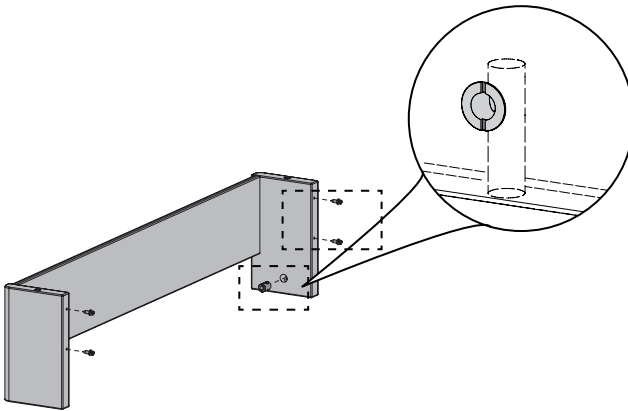
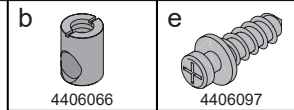

11.5 Fitting top bed

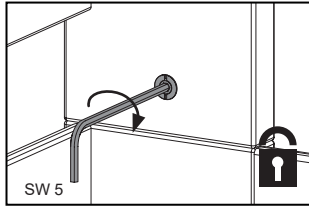
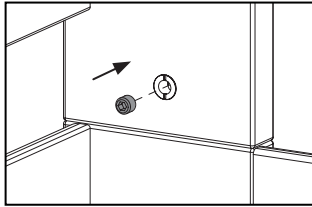
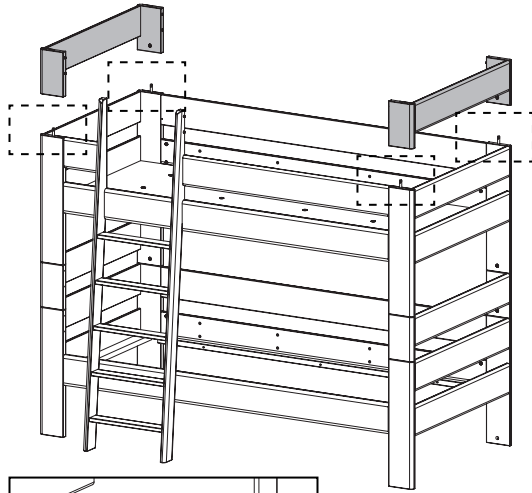

11.6 Fitting rail boards

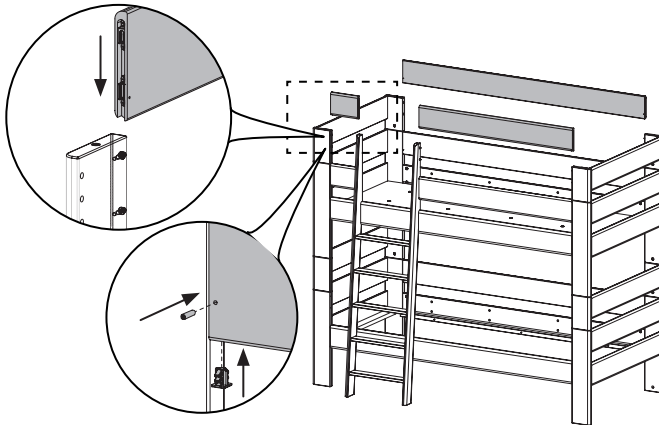

⚠ IMPORTANT

- Drive in grub screw to leave it flush with surface!

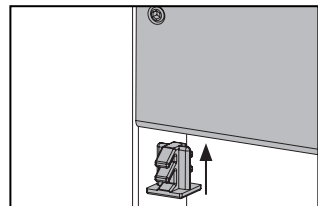
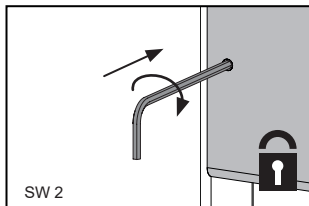
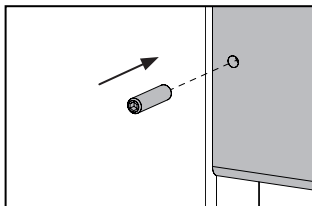

12. Cover screws

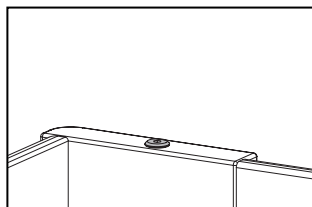
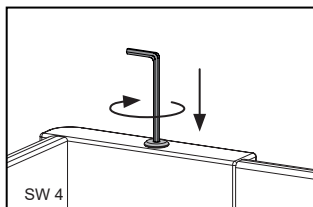
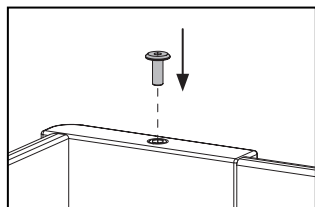
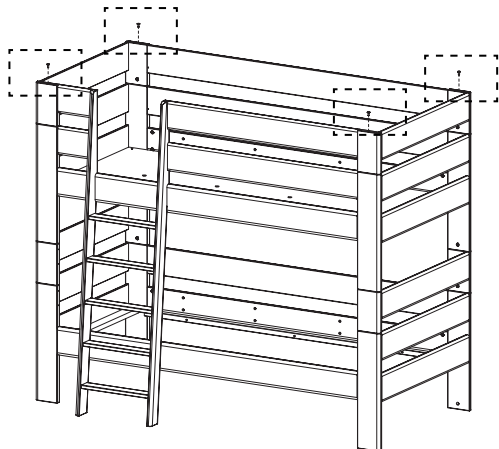

For den bed only:

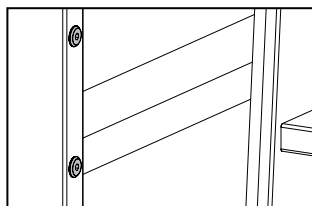
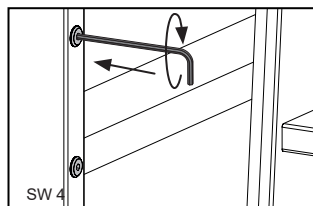
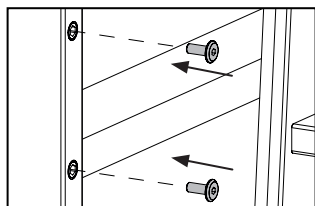
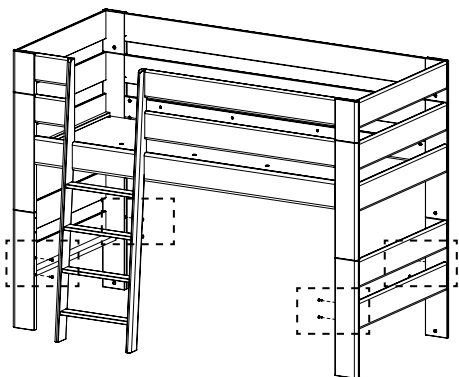

13. Cover cap

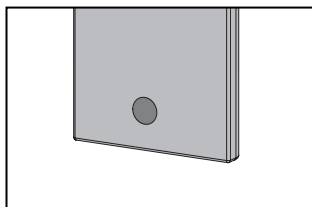
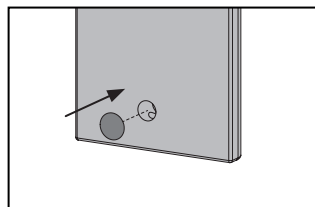
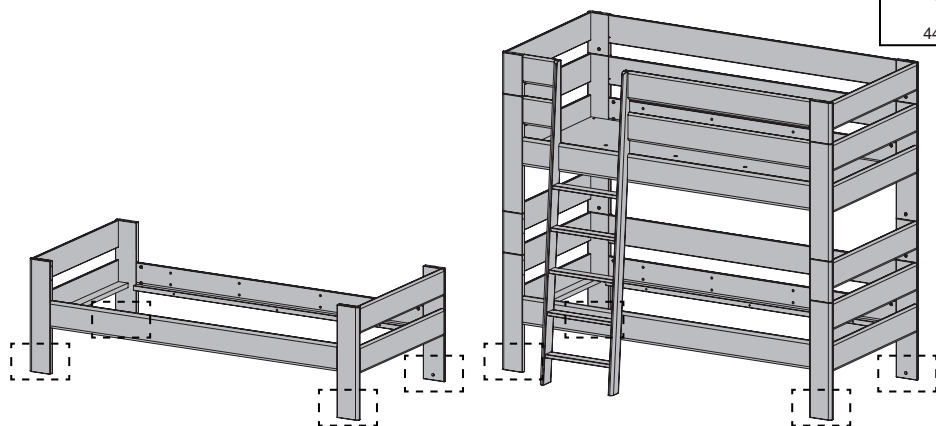

TEAM 7

TEAM 7 Natürlich Wohnen GmbH

Braunauer Str. 26

4910 Ried im Innkreis, AUSTRIA

Assembly Hotline: +43/7752-977321

www.team7-home.com

Errors and omissions excepted. All rights reserved for printing and typesetting errors.

Copyright

All parts of this document are protected by copyright. Any use above and beyond the narrow confines of copyright law is not permitted without the consent of TEAM 7 GmbH and is a punishable offence. This applies in particular to reproduction, microfilming as well as saving and processing in electronic systems.