



Persone necessarie per il montaggio
People required for assembly
Anzahl der Monteure

L'INSTALLAZIONE DEVE ESSERE
ESEGUITA DA PERSONALE
SPECIALIZZATO

INSTALLATION MUST BE CARRIED
OUT BY SPECIALIZED PERSONNEL
DIE MONTAGE DARF NUR VON
AUSGEBILDETEM FACHPERSONAL
VORGENOMMEN WERDEN

Assicurarsi preventivamente che la parete sia idonea a sostenere il peso degli elementi pensili nelle condizioni di utilizzo del cliente
Make sure beforehand that the wall is strong enough to take the weight of wall units under the customer's normal conditions of use.
Stellen Sie vorab sicher, dass die Wand für das Gewicht der Hängeschrankelemente und für die vorgesehene Verwendung geeignet ist.

Per motivi di sicurezza il fissaggio a parete va fatto con opportuni tasselli in funzione del tipo di muratura, per questo motivo viti e tasselli non sono forniti
For safety reasons, the fastening to the wall must be done using appropriate anchor anchors to suit the type of wall in question, which is why fixing hardware is not included
Aus Sicherheitsgründen müssen die Pfosten mit Dübeln befestigt werden, die für den jeweiligen Wandtyp geeignet sind. Aus diesem Grund liegen die Dübel nicht bei.

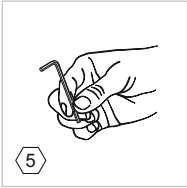

5

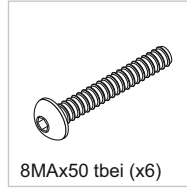
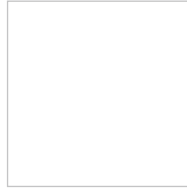
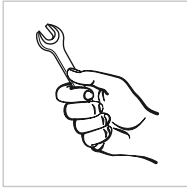

8MAx50 tbei (x6)



8MAx25 tbei (x12)

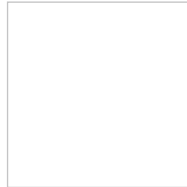

8MAx20 tbei (x34)

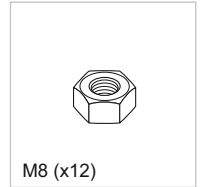

M8 (x12)

1

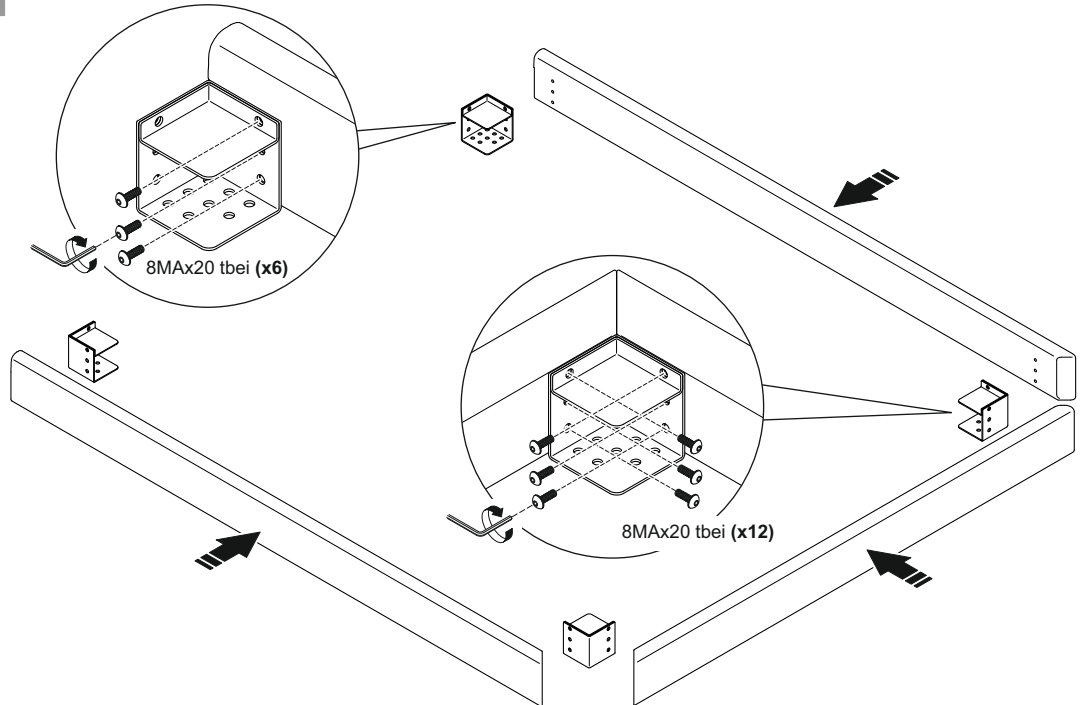
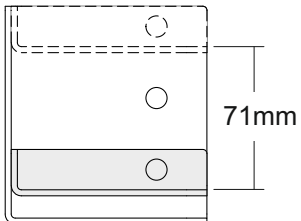
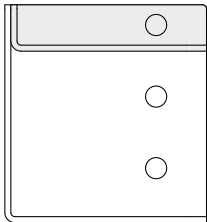

2

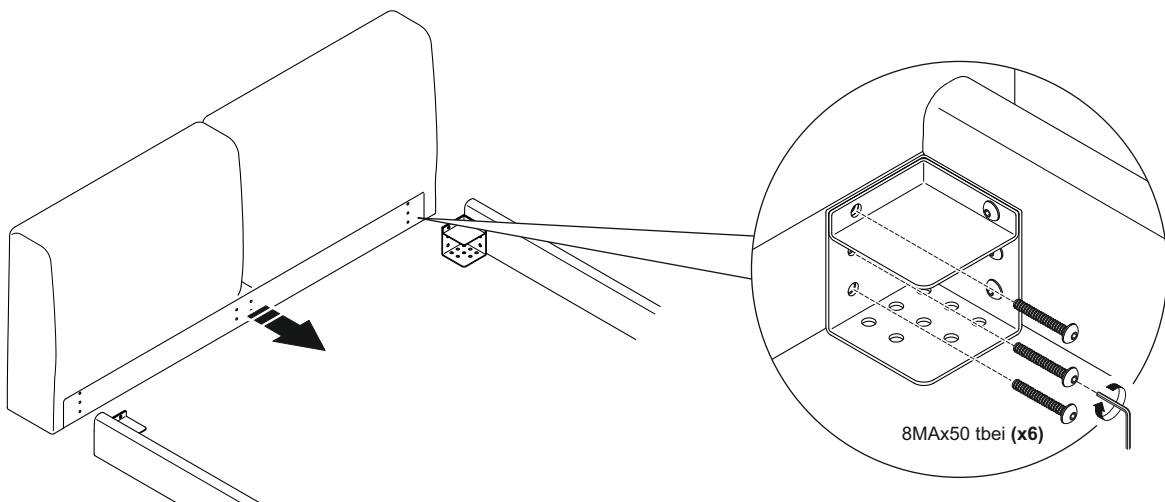

3

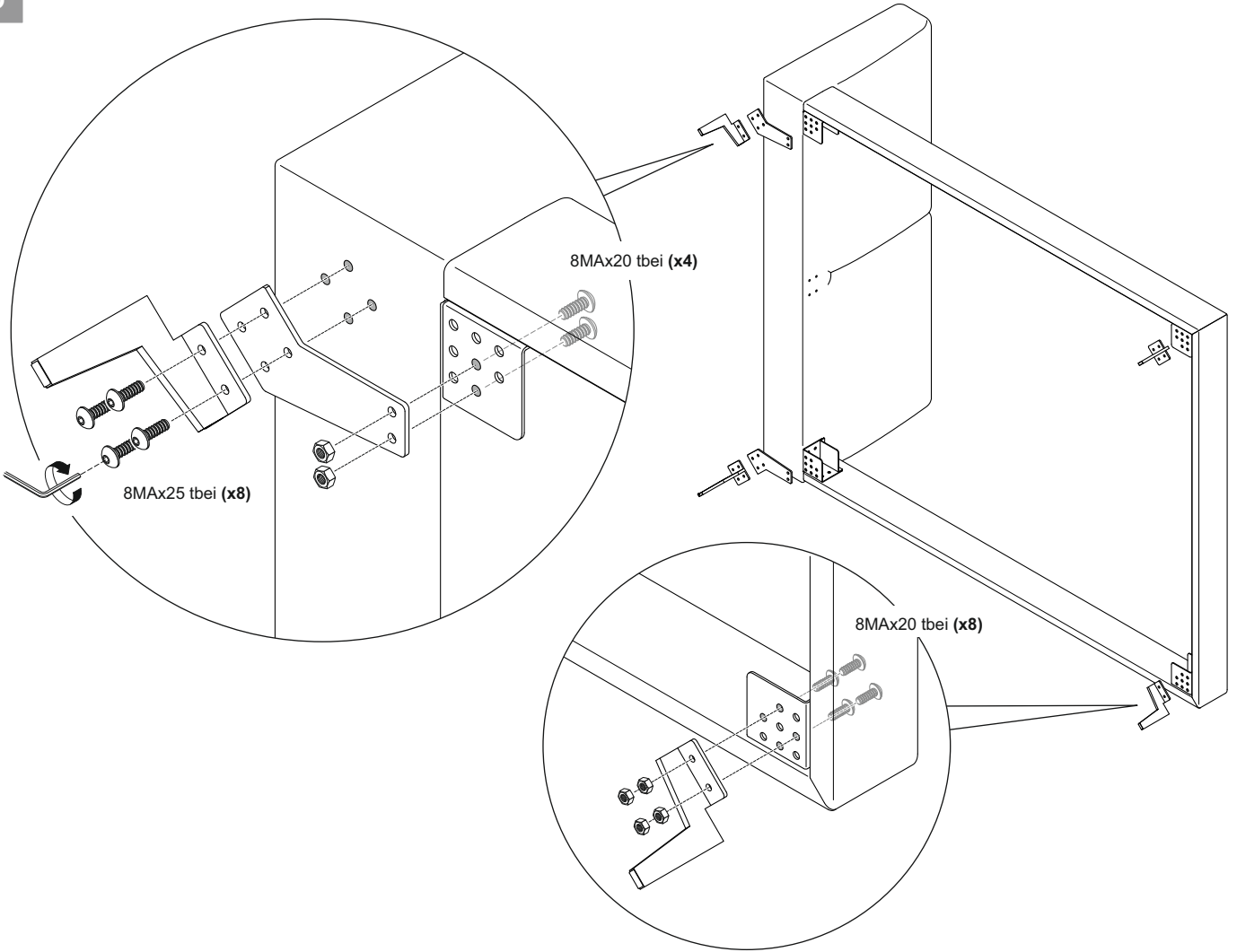

4

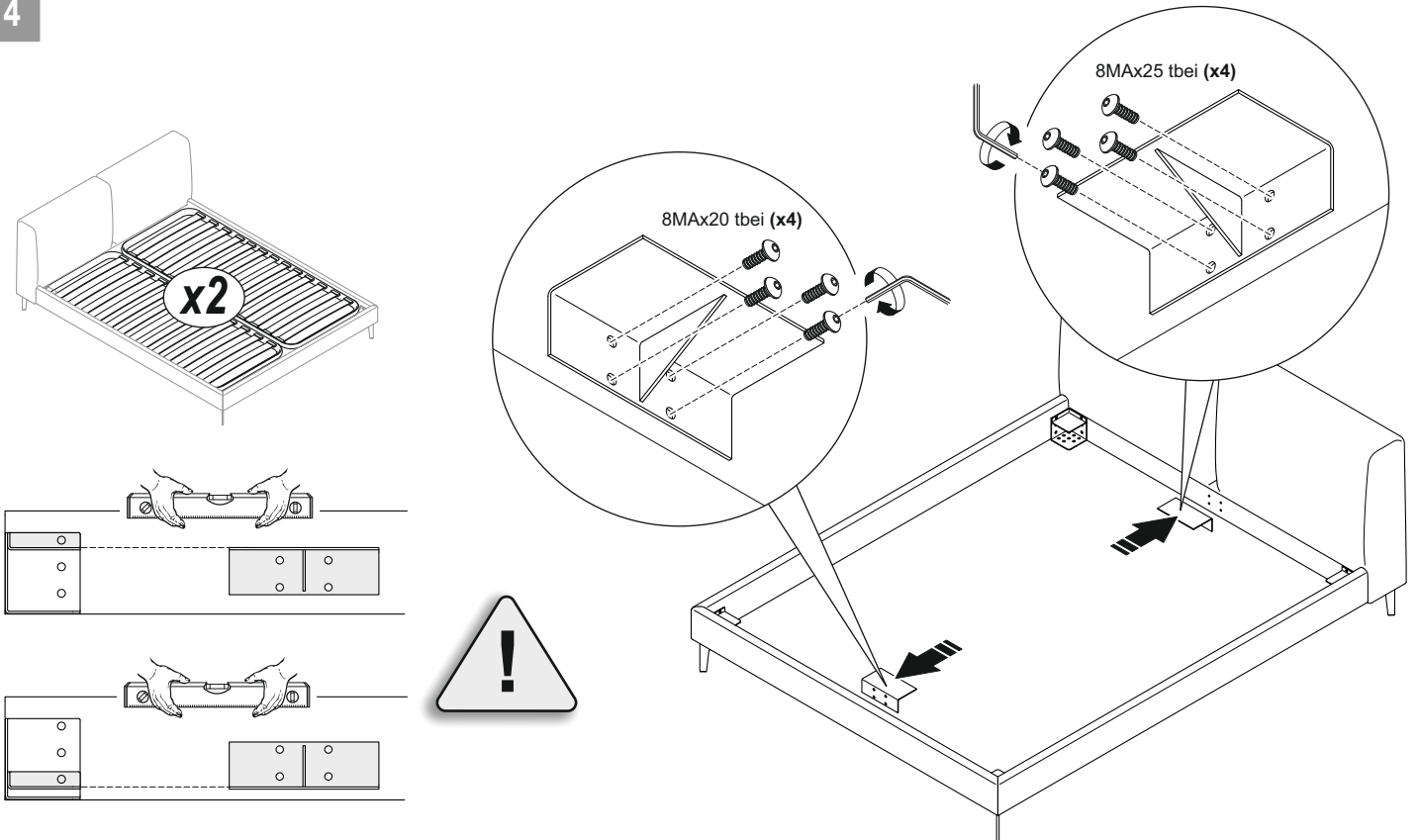

SCHEMA MONTAGGIO GIUNTO DI UNIONE E SUPPORTO PIEDE

CONNECTING JOINT AND FOOT SUPPORT ASSEMBLY DIAGRAM / MONTAGE VON VERBINDUNGSELEMENT UND STELLFUSS

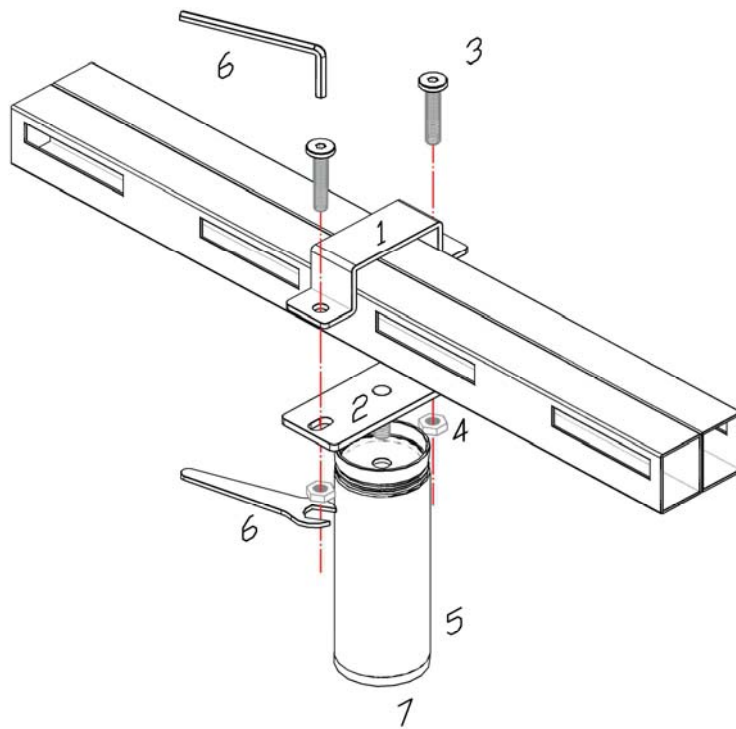

MONTAGGIO / ASSEMBLY / MONTAGE

- Inserire il gommino regolabile (7) nel piede (5) e avvitare fino a chiusura completa.
Fit the adjustable rubber cap (7) on the foot (5) and screw it on all the way
Schrauben Sie den höhenregulierbaren Gummifuß (7) von unten in den Stellfuß (5) und ziehen Sie ihn fest.

- Avvitare il piede sulla staffa inferiore (2)
Screw the foot onto the lower bracket (2)
Schrauben Sie den Stellfuß in die untere Halterung (2)

- Unire le due parti del giunto (staffa 1 e 2) usando la vite M8x40 (3) e il dado M8 (4)
Join the two parts of the joint (bracket 1 and 2) together using the M8x40 (3) screw and M8 nut (4)
Verbinden Sie beide Teile des Verbindungselements (Halterung 1 und 2). Verwenden Sie dazu die Schrauben M8x40 (3) und die Mutter M8 (4)

- Bloccare le vite con le apposite chiavi (6)
Use the relevant Allen key and spanner to tighten the screws fully (6)
Ziehen Sie die Schrauben mit den entsprechenden Schlüsseln fest (6)

- Regolare l'altezza del piede svitando il gommino, facendo attenzione di tenerlo un paio di millimetri sollevato dal piano d'appoggio
Adjust the height of the foot by unscrewing the rubber cap, making sure you keep it lifted a couple of millimetres off the surface it stands on
Stellen Sie durch Drehen des Gummifußes die richtige Höhe ein. Achten Sie dabei darauf, einen kleinen Abstand von einigen Millimetern zwischen Gummifuß und Stellfläche zu lassen.

- Dopo qualche giorno di utilizzo ricontrollare il serraggio di viti e piede
After a couple of days' use, check the tightness of the screws and foot again.
Kontrollieren Sie den Sitz von Stellfuß und Schrauben nach einigen Tagen.