

XENIA

27394/27433 Lowboard 200cm

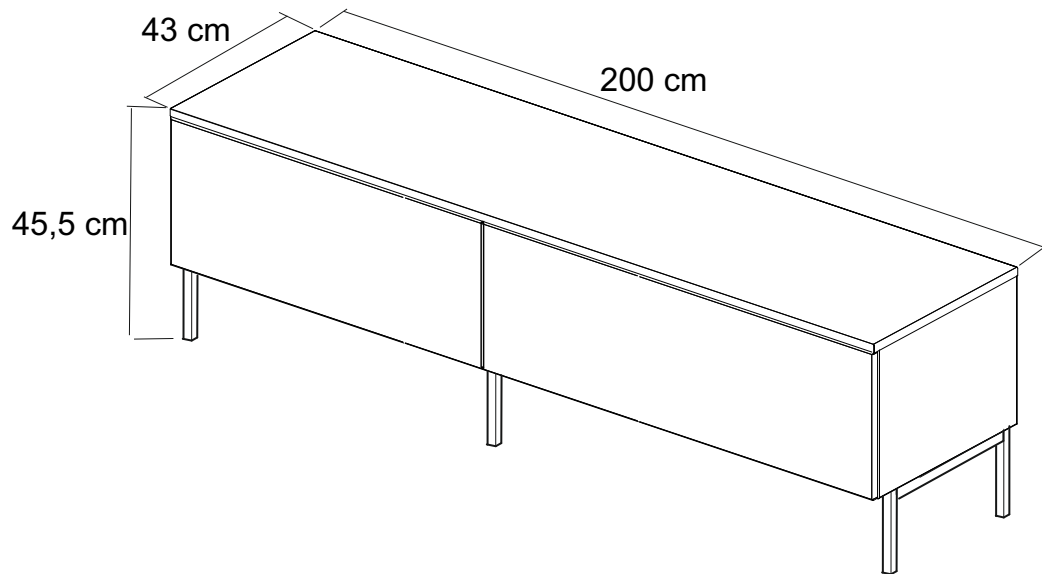

Wichtig

Anleitung vor Gebrauch sorgfältig durchlesen und für spätere Anwendung aufbewahren

Important

Lire attentivement ce mode d'emploi avant utilisation, et le conserver pour toute consultation ultérieure

Importante

Leggere attentamente le istruzioni prima dell'uso e conservarle per future consultazioni

Important

Read these instructions carefully before use, and keep them safely for future reference



Warnhinweise

Consignes de sécurité

Avvertenze

Warnings

Bestimmungsgemäßer Gebrauch

Das Möbel nur dem Zweck entsprechend verwenden. Eine dauerhafte Funktionsfähigkeit ist nur durch sachgerechte Nutzung und regelmässige Unterhaltspflege gegeben.

Usage prévu

Ce meuble doit être utilisé uniquement aux fins auxquelles il est destiné. Seuls une utilisation appropriée et un entretien régulier garantiront un usage durable.

Uso previsto

Utilizzare il mobile secondo la finalità a cui è stato destinato. Una funzionalità duratura è garantita solo da un uso appropriato e da una cura regolare.

Proper usage

This furniture must only be used for the intended purpose. It will serve you dependably for years, but only with appropriate usage and regular care.

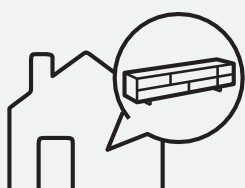

Anwendungsort

Dieses Möbel eignet sich für den allgemeinen, privaten Wohnbereich. Es eignet sich nicht für den Nass-, Aussen- oder gewerblichen Bereich.

Emplacement

Ce meuble est destiné à un usage en local d'habitation. Il ne convient pas pour des espaces humides, en extérieur ou commerciaux.

Luogo di utilizzo

Questo mobile è destinato all'uso in locali residenziali privati. Non è indicato per locali umidi, all'aperto o per locali commerciali.

Place of use

This furniture is intended for use in domestic living quarters. It is not suitable for use in wet zones, outdoors, or in commercial areas.



WARNUNG

Gefahr durch Verschlucken und Ersticken!

Tüten und Folien sind kein Spielzeug! Darauf achten, dass Kleinkindern nicht an Verpackungsmaterialien, Plastiktüten und Kleinteile gelangen!

AVERTISSEMENT Risque d'ingestion et d'étouffement!

Les sachets et films plastique ne sont pas des jouets! Veiller à ce que les petits enfants n'aient pas accès aux matériaux de l'emballage, aux sacs plastique et aux petits composants!

AVVERTIMENTO

Rischio di ingestione e di soffocamento!

Sacchetti e pellicole non sono giocattoli! Badare che i bambini piccoli non abbiano accesso ai materiali dell'imballaggio, ai sacchetti di plastica e ai piccoli pezzi!

WARNING

Danger of swallowing and suffocation!

Bags and foils are not playthings! Keep packaging materials, plastic bags and small parts out of reach of infants!

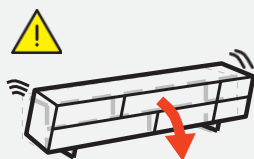

ACHTUNG

Kippgefahr!

Dieses Möbel kann kippen und muss daher von einer Fachperson an Wand oder Decke befestigt werden. Die Befestigungsart ist von der Wand- oder Deckenbeschaffenheit (z.B. Beton, Gips, Backstein oder Holz) abhängig.

ATTENTION

Risque de basculement!

Ce meuble est susceptible de basculer, c'est pourquoi il doit être fixé par un professionnel au mur ou au plafond. Le choix du système de fixation dépend de la consistance du mur ou du plafond (par ex. ciment, plâtre, briques ou bois).

ATTENZIONE

Rischio di ribaltamento!

Questo mobile può ribaltarsi e perciò deve essere fissato alla parete o al soffitto da uno specialista. La scelta del sistema di fissaggio dipende dalla consistenza della parete o del soffitto (ad es. cemento, gesso, mattoni o legno).

CAUTION

Danger of tipping!

This furniture can tip, and must therefore be professionally fastened to the wall or ceiling. The type of fastening depends on the wall or ceiling material (such as concrete, plaster, bricks or timber).



Entsorgung

Möbel, die nicht mehr verwendet werden, der fachgerechten Entsorgung übergeben. Wenden Sie sich an Ihre lokale Entsorgungsstelle.

Élimination

Tout meuble inutilisé doit être éliminé correctement. S'adresser à un centre de recyclage pour l'élimination des déchets.

Smaltimento

Smaltire correttamente i mobili non più utilizzati. Rivolgersi al proprio ecocentro per lo smaltimento dei rifiuti.

Disposal

Furniture that cannot be repaired or has reached the end of its useful life should be handed over for professional disposal. Please contact your local waste disposal authority.

Montagehinweise

Instructions de montage

Istruzioni di montaggio

Assembly guidelines



VORSICHT
Verletzungsgefahr!
Darauf achten, dass sich Kleinkinder nicht im Montagebereich aufhalten und an Möbeln hochziehen bzw. hinaufklettern!

PRÉCAUTION
Risques de lésions!
Tenir les petits enfants hors de portée de la zone de montage et les empêcher de soulever les meubles ou de monter dessus!

PRECAUZIONE
Pericolo di lesioni!
Tenere i bambini piccoli fuori dall'area di montaggio e impedire loro di sollevare o di salire sui mobili!

CAUTION
Risk of injury!
Keep infants away from the assembly area and prevent them from mounting or climbing up furniture!



Montageschäden verhindern
Einzelteile beim Auspacken und während Montage nur auf weiche Unterlagen legen/stellen. Größere Teile vor Kippen/Umfallen sichern.

Éviter les défauts de montage
Lors du déballage, déposer tous les composants sur une surface souple. Veiller à ce que les éléments de plus grande taille ne se renversent pas et ne basculent pas.

Evitare danni di montaggio
Durante il disimballaggio depositare i singoli pezzi su superfici morbide. Assicurarsi che i pezzi più grandi non si rovescino o si ribaltino.

Prevent assembly damage
Use a soft underlay for all parts during assembly. Secure large components from tipping or falling over.



Personen
Anzahl Personen, die für die Montage benötigt werden.

Personnes
Nombre de personnes nécessaires au montage.

Persone
Numero di persone necessarie per il montaggio.

Personnel
Number of people required for assembly work.



Montagezeit
Ungefährer Zeitbedarf in Minuten.

Temps de montage
Temps approximatif requis en minutes.

Tempo di montaggio
Tempo approssimativo richiesto in minuti.

Assembly time
Approximate time required in minutes.

Erforderliches Werkzeug

Outils nécessaires

Strumenti necessari

Tools required

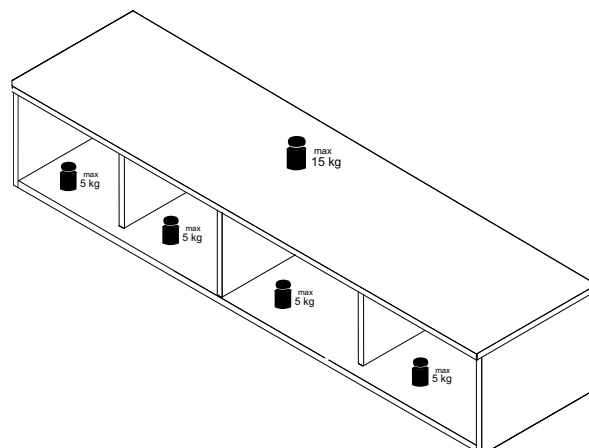

**Montage-
Hinweise**

**Instructions de
montage**

**Istruzioni di
montaggio**

**Assembly
guidelines**

Möbelteile

**Composants du
meuble**

Parti di mobili

**Furniture compo-
nents**

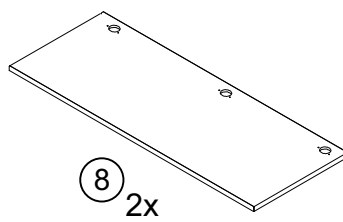
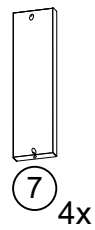
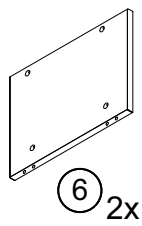
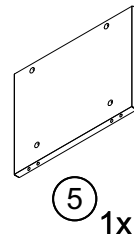
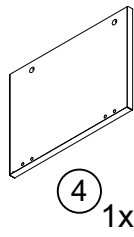
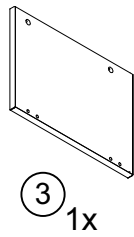
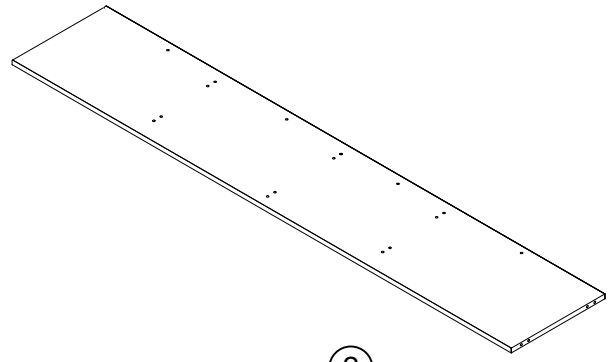
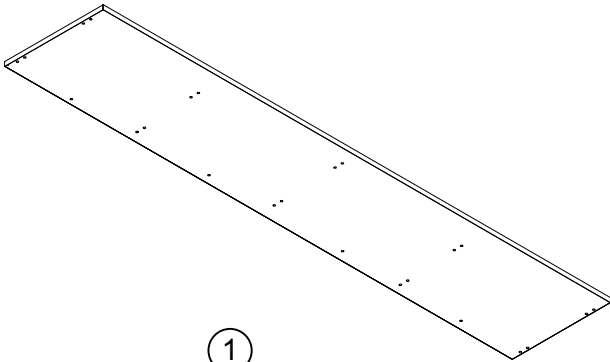

Kleinteile

Petits éléments

Piccoli pezzi

Small parts

Box 2



(A) 28x



(B) 28x



(C) 36x



(D) 12x
(4x16)



(E1) 4x
(5x9)

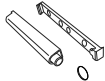

(E) 2x



(G) 28x

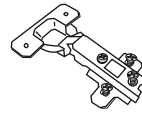

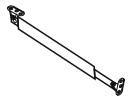

(J) 6x

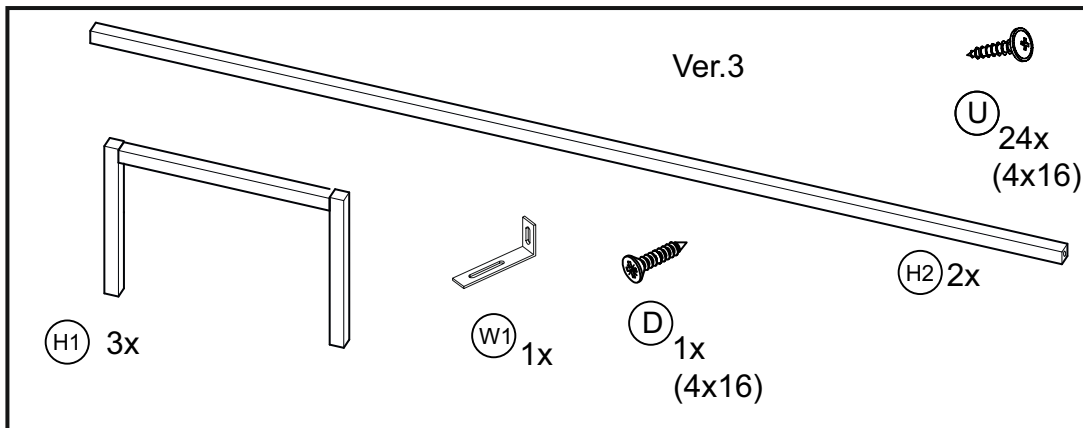
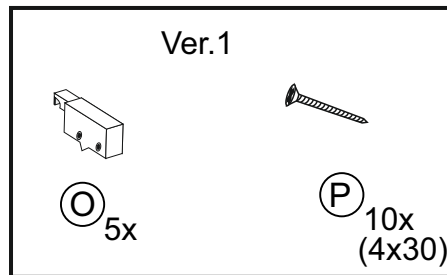
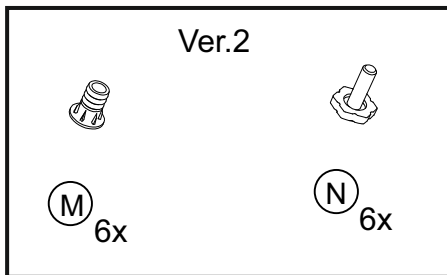

(W) 4x



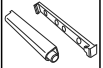

1

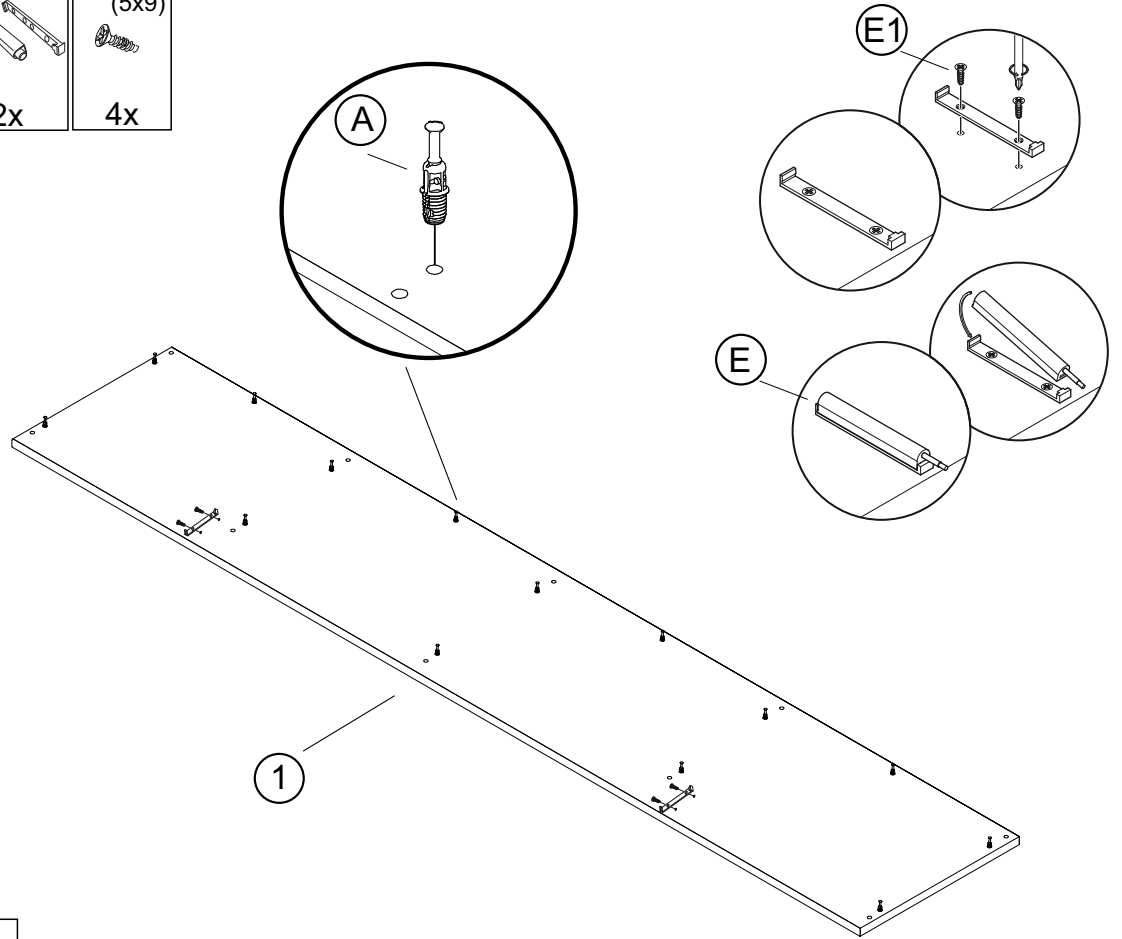
| | | |
|-----------------------------------------------------------------------------------|-----------------------------------------------------------------------------------|-----------------------------------------------------------------------------------|
| (A) | (E) | (E1) (5x9) |
|  |  |  |
| 14x | 2x | 4x |



2

| | |
|-------------------------------------------------------------------------------------|-------------------------------------------------------------------------------------|
| (A) | (C) |
|  |  |
| 10x | 4x |

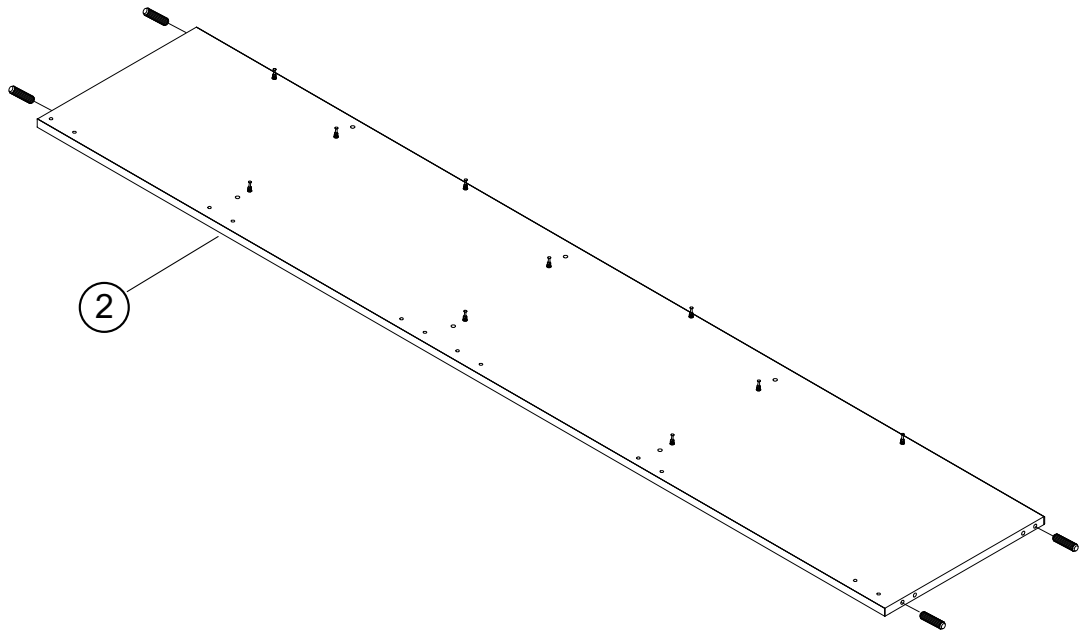

3

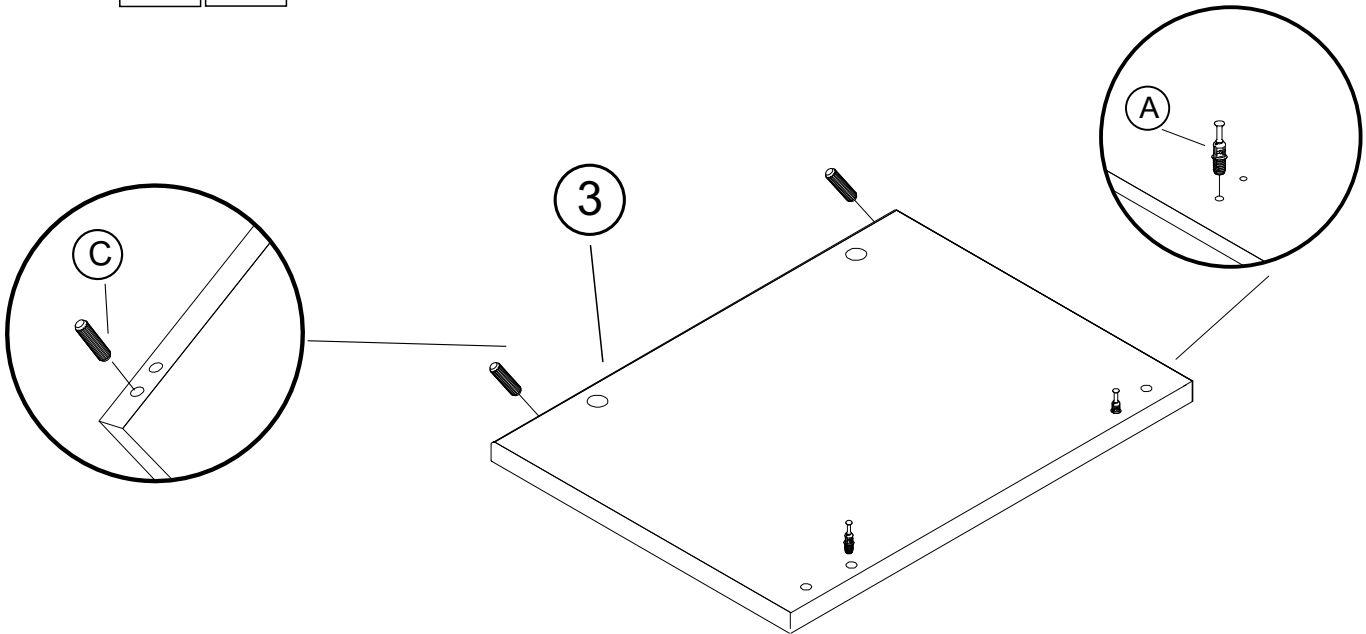
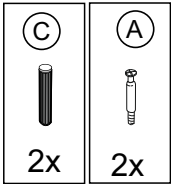

4

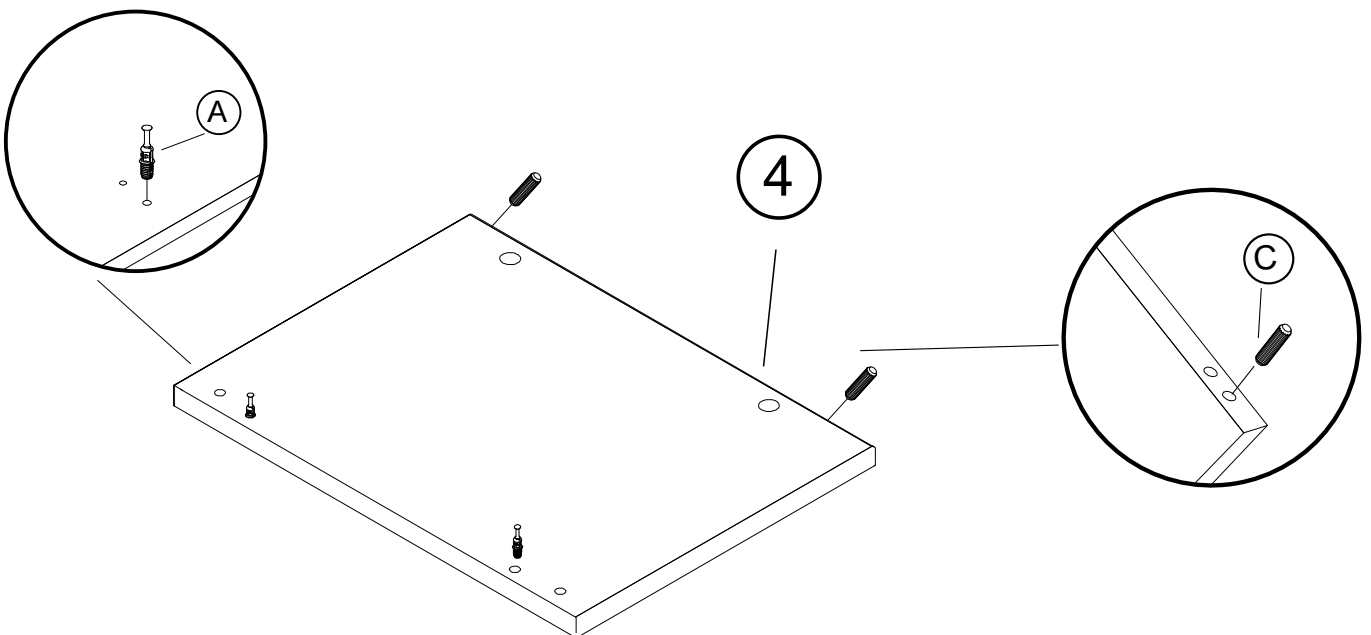
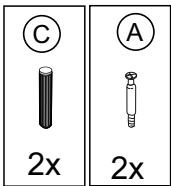

5

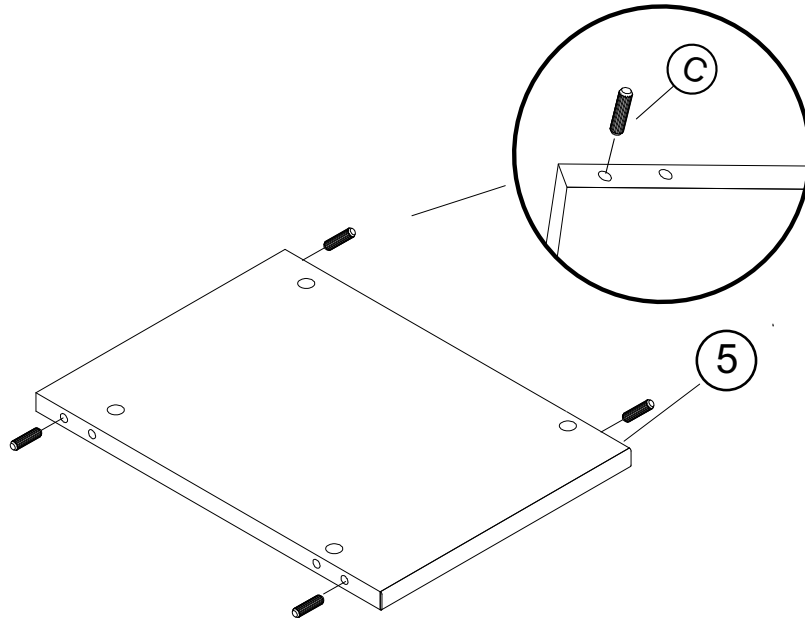
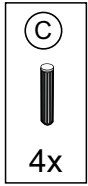

6

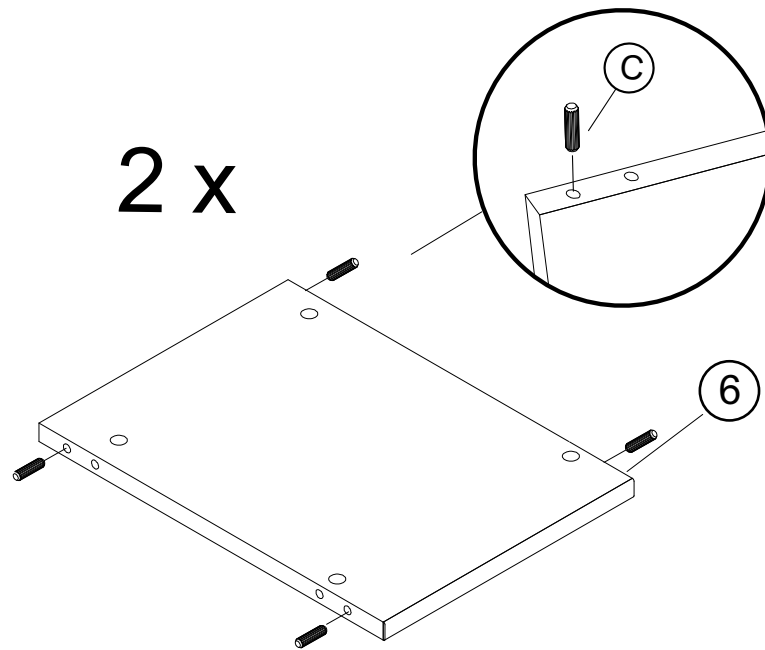
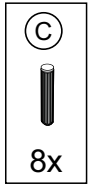

7

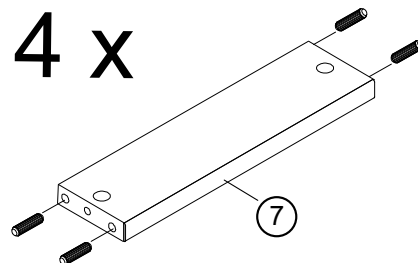
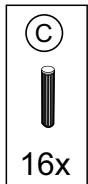

10

(B)

4x

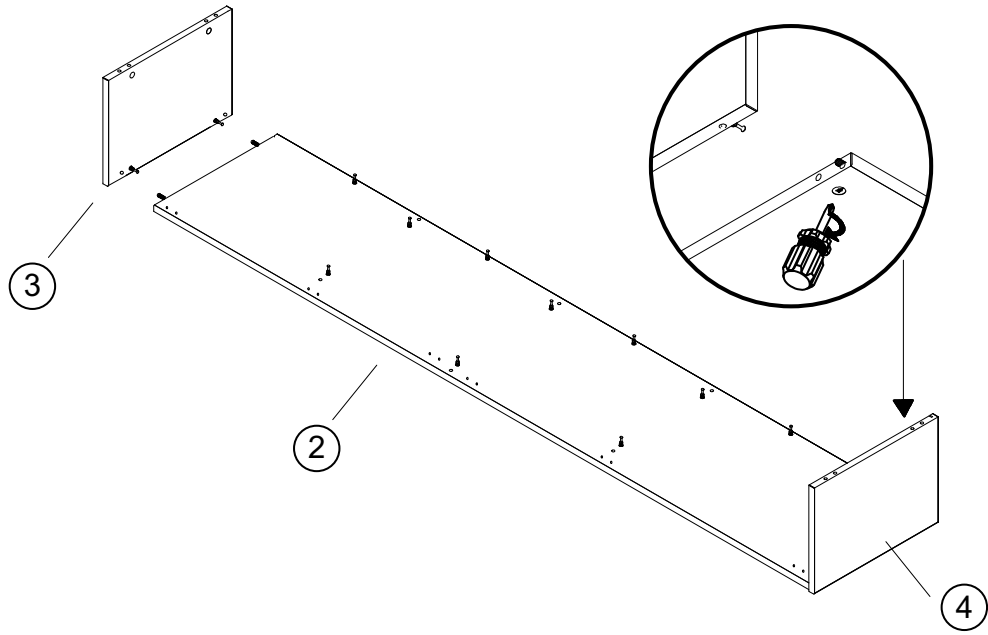

11

(B)

6x

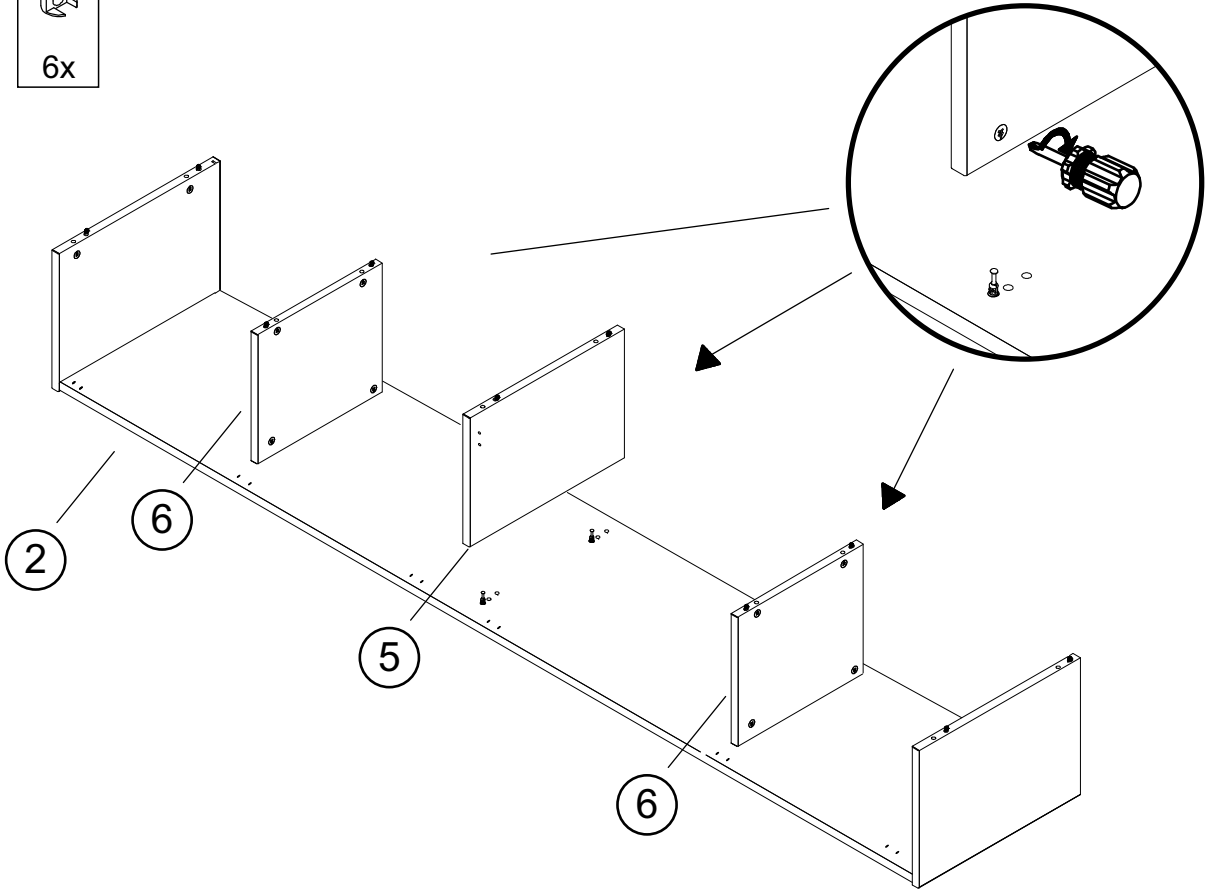

12

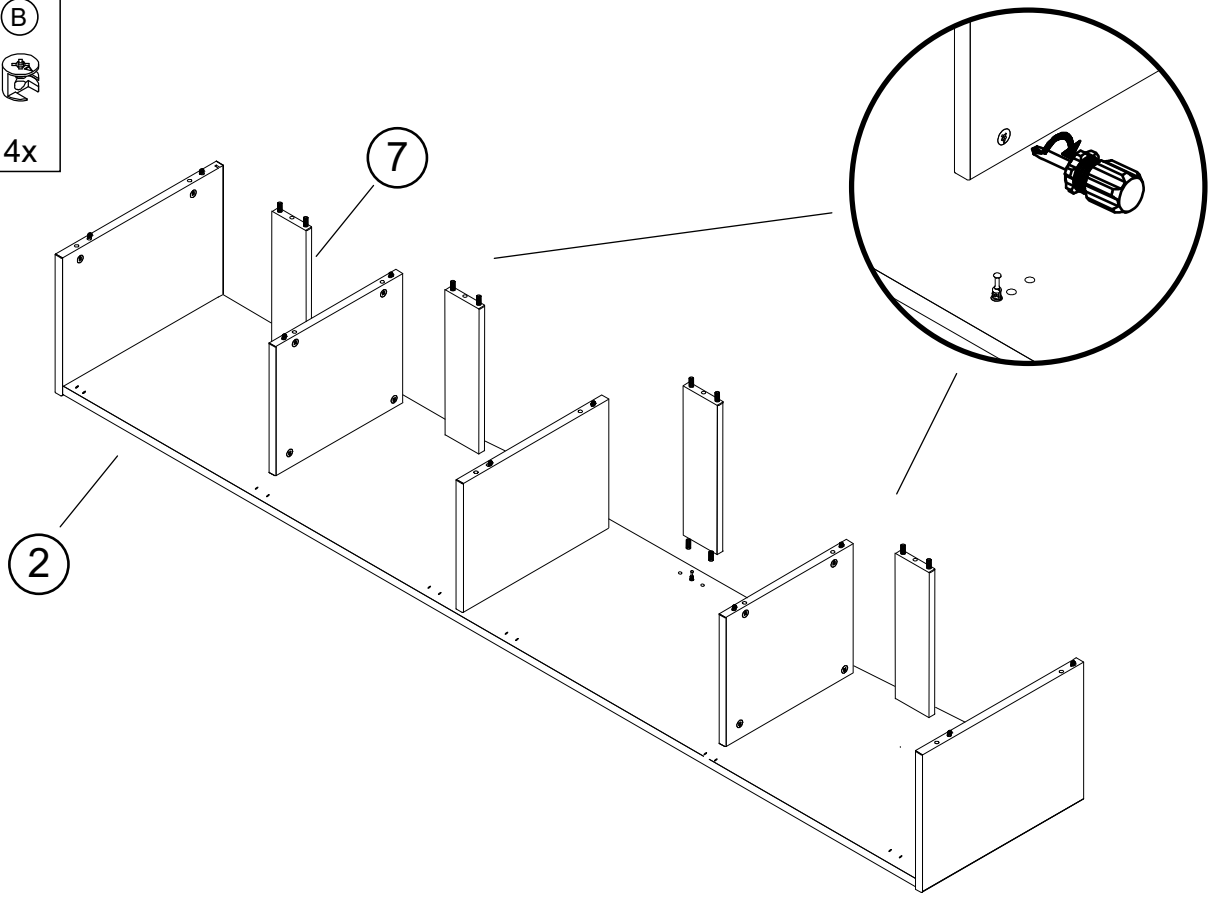

13

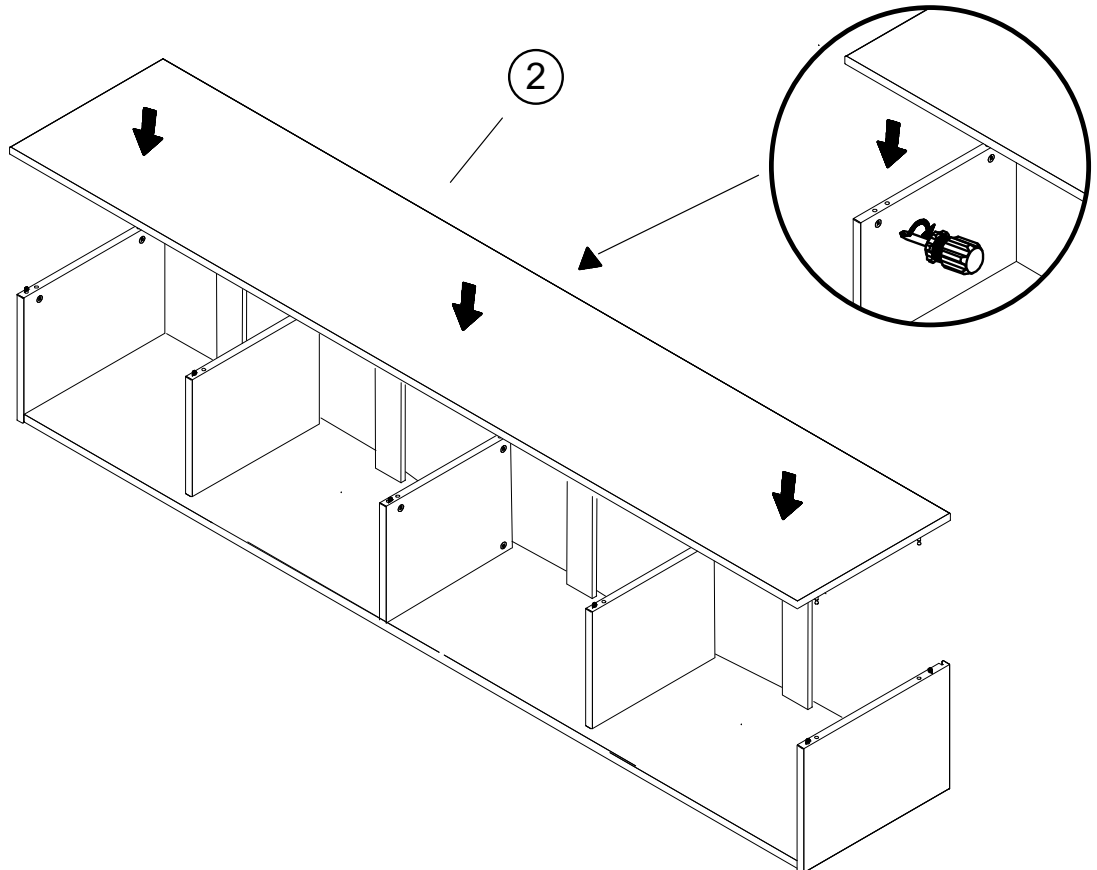

Ver.1

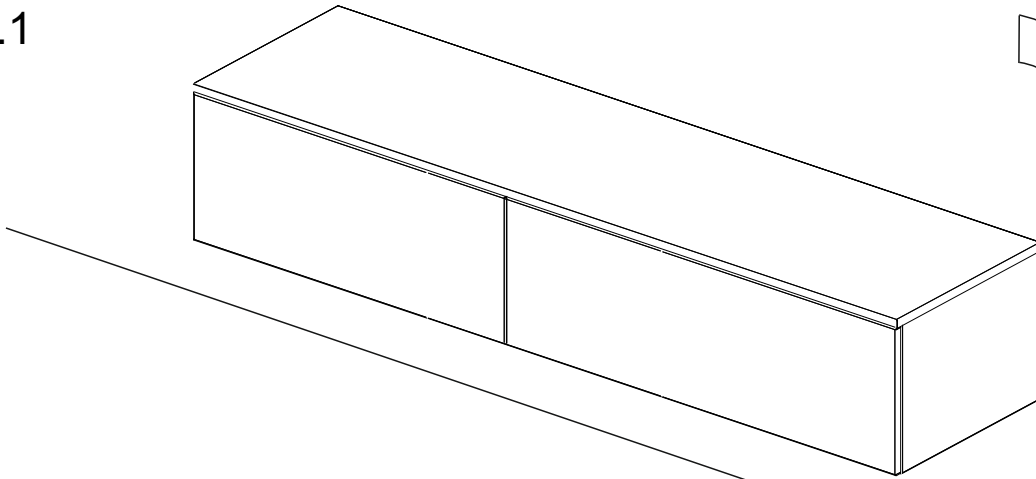

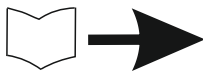
 **12**

Ver.2

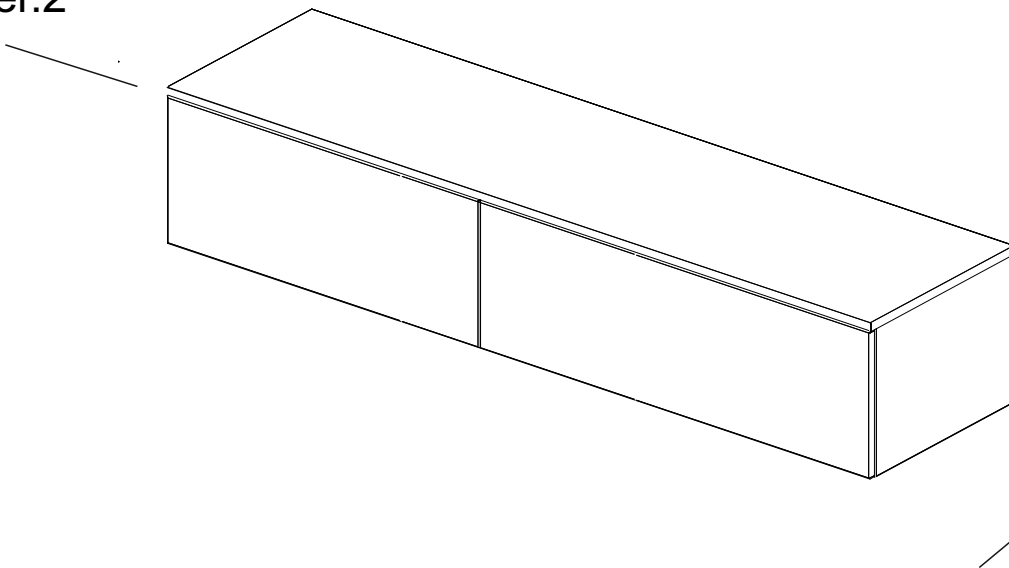

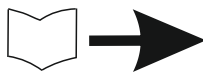
 **13**

Ver.3

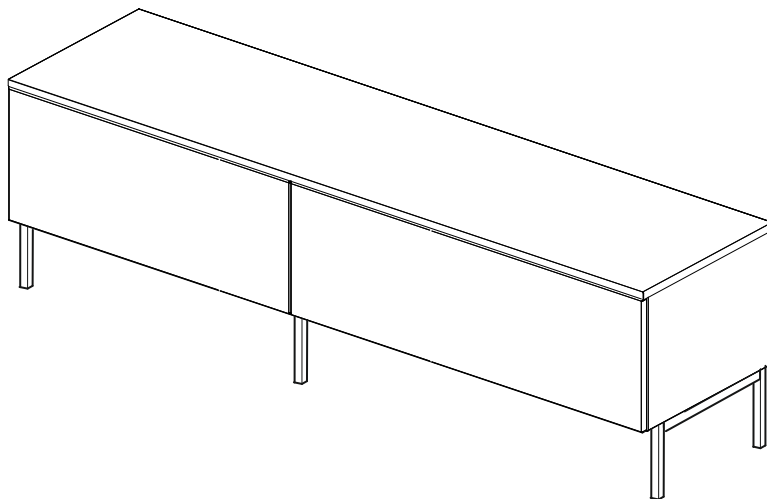

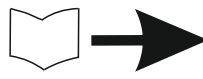
 **14**

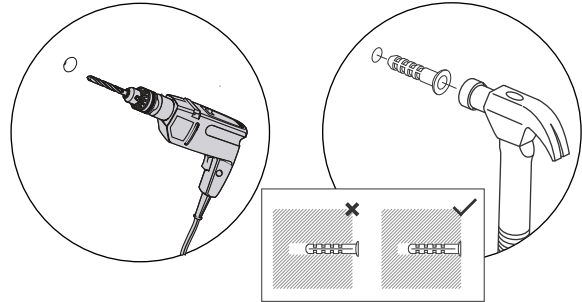
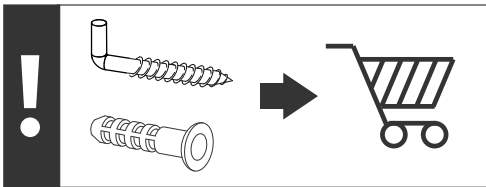
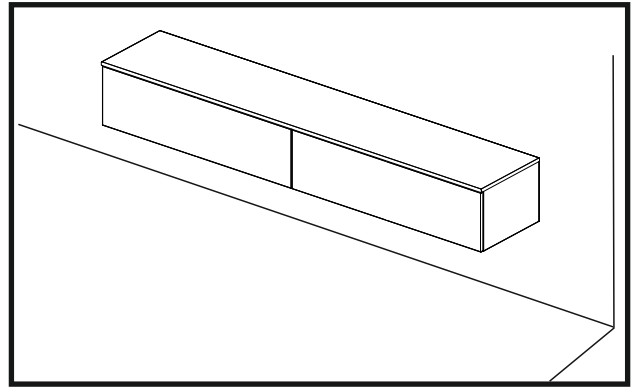

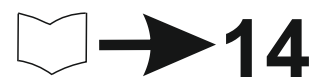
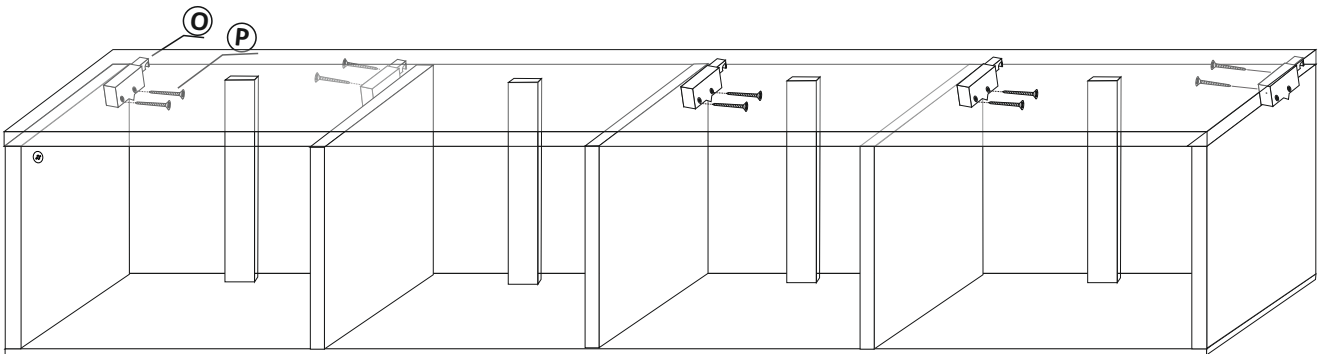
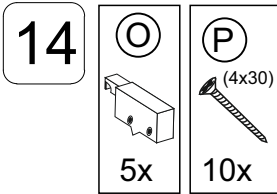

ver. 1

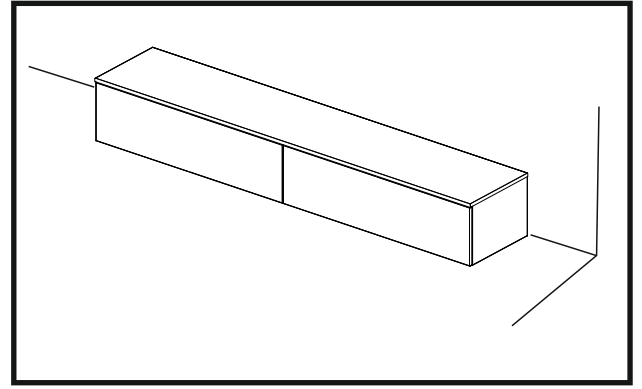

Ver.2



14

| | |
|-----------------------------------------------------------------------------------------|-----------------------------------------------------------------------------------------|
|  6x |  6x |
|-----------------------------------------------------------------------------------------|-----------------------------------------------------------------------------------------|

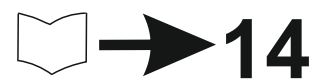
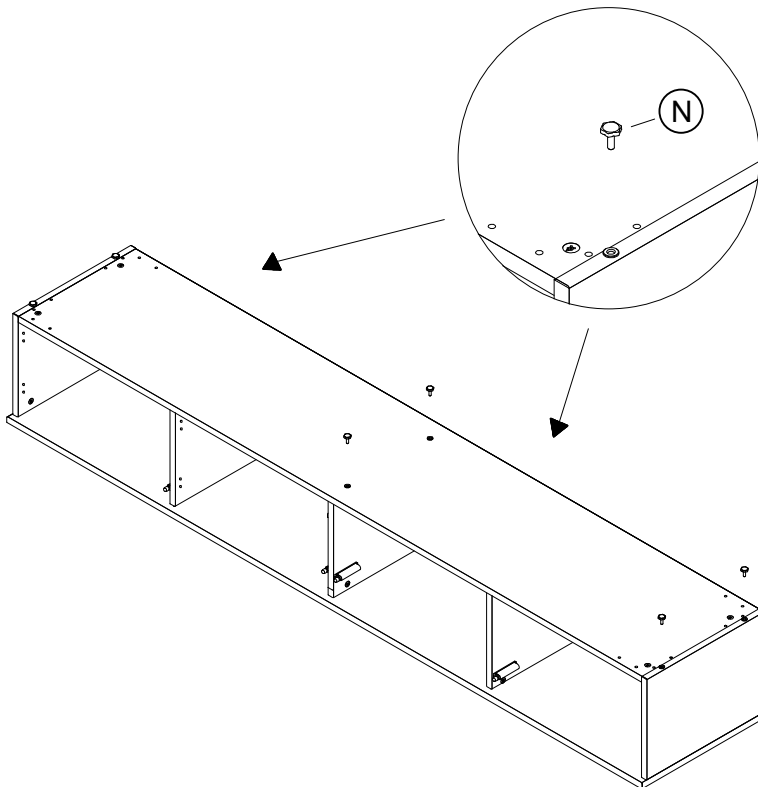
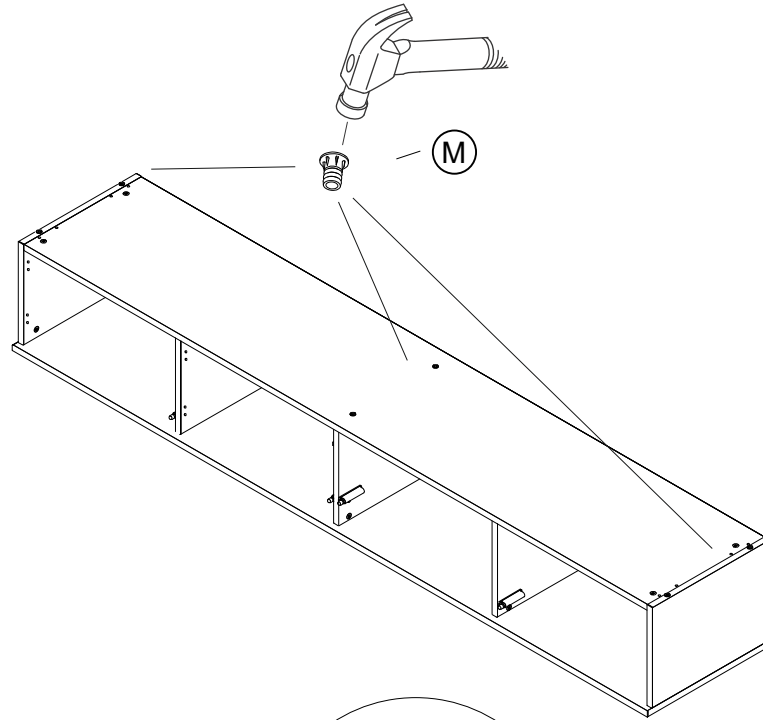

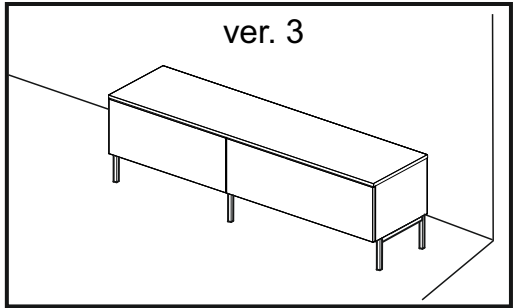

14

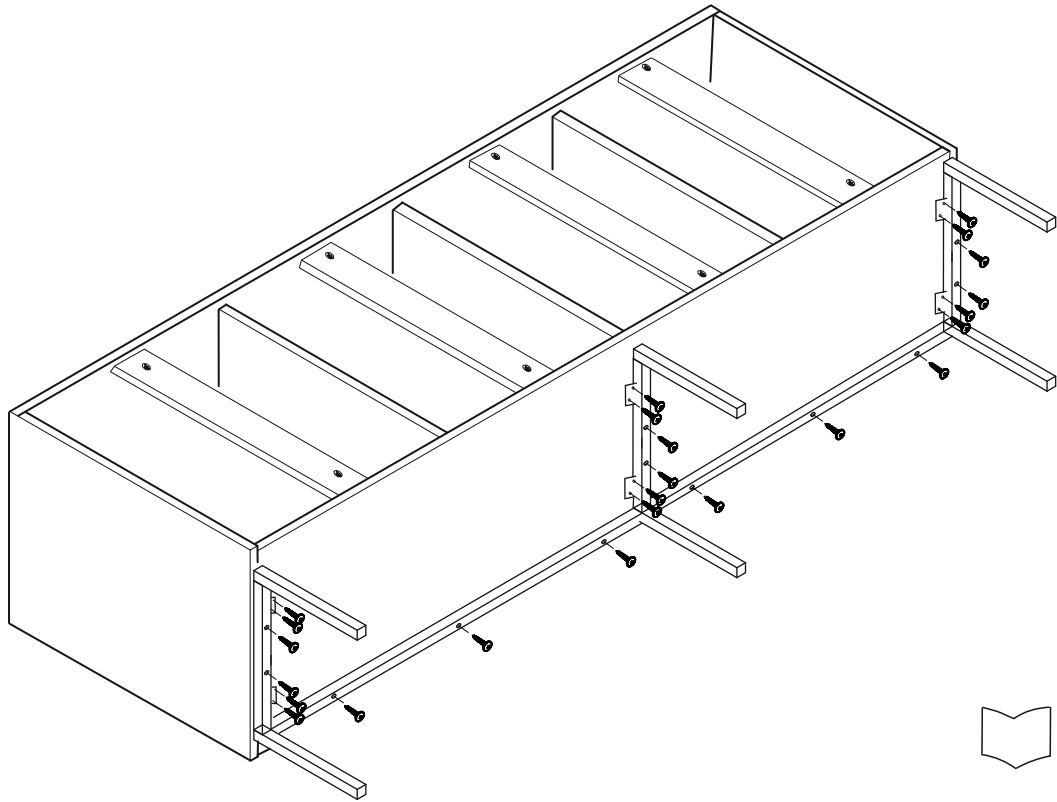
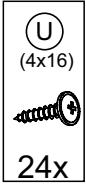

15

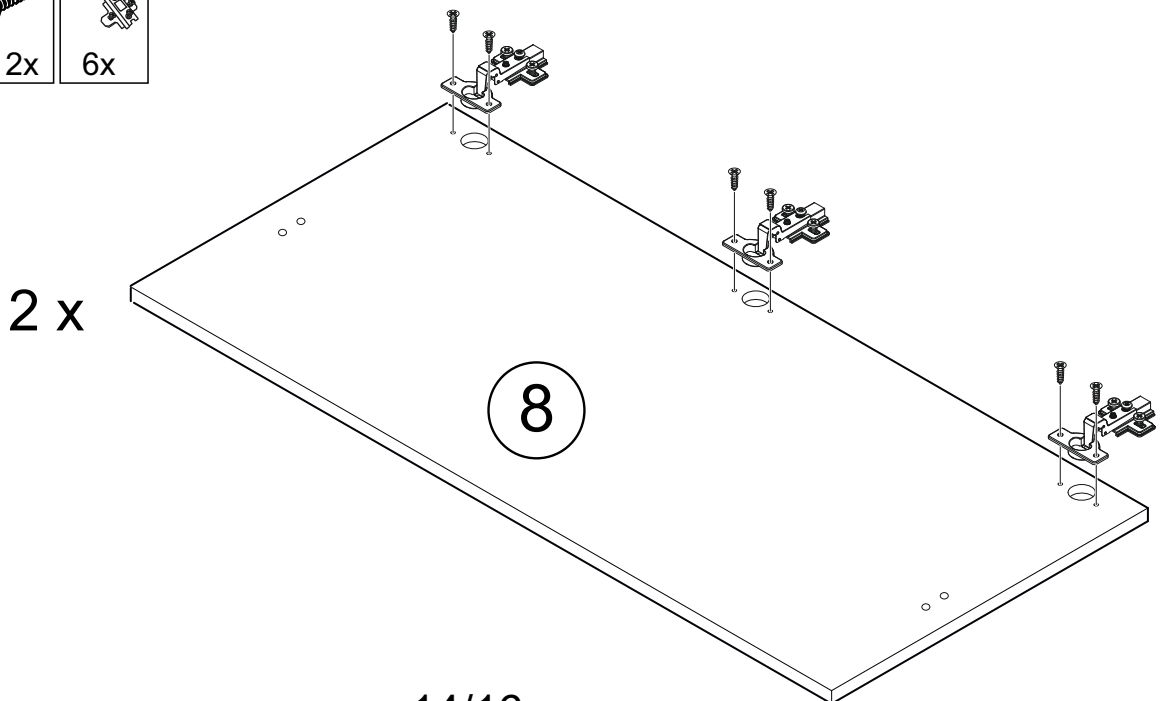
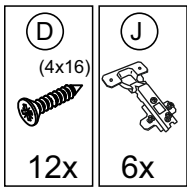

Allgemeine Hinweise

Indications générales

Indicazioni generali

General guidelines

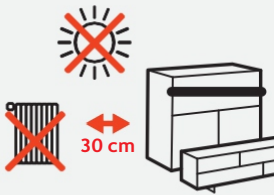

Vermeiden Sie direktes Sonnenlicht. Dies kann zu Farbveränderungen führen. Halten Sie mindestens 30 cm Abstand zu Heizkörpern.

À éviter Une exposition directe aux rayons du soleil peut entraîner une variation de la couleur. Maintenir une distance d'au moins 30 cm entre le produit et les radiateurs.

Da evitare L'esposizione alla luce diretta del sole può provocare cambiamenti di colore. Mantenere una distanza minima di 30 cm dai radiatori.

To be avoided Direct sunlight can cause colour changes. Place at least 30 cm away from heating radiators.



Empfindliche Bodenbeläge Vermeiden Sie Kratzer und Druckstellen auf empfindlichen Böden, indem Sie an Ihrem Möbel Schutzgleiter anbringen.

Sols délicats Monter des embouts de protection pour pieds de meuble, afin d'éviter rayures et bosses sur les sols délicats.

Pavimenti sensibili Montare dei piedini protettivi per mobili, onde evitare graffi e ammaccature sui pavimenti sensibili.

Sensitive flooring Fit protective glides to your furniture to prevent scratching or denting sensitive flooring.



Schrauben Schrauben regelmässig nachziehen (z.B. halbjährlich), um eine einwandfreie, zuverlässige Funktion zu gewährleisten.

Vis & boulons Resserrer régulièrement les vis et boulons (par ex. tous les 6 mois) pour garantir une utilisation fiable et impeccable du produit.

Viti & bulloni Stringere regolarmente viti e bulloni (ad es. ogni 6 mesi) per garantire una funzionalità affidabile e impeccabile.

Screws and bolts Screws and bolts should be regularly tightened (e.g. every six months) to ensure faultless dependability.

Bänder Bänder regelmässig kontrollieren (ca. halbjährlich) und falls nötig neu einstellen.

Charnières Contrôler régulièrement les charnières (par ex. tous les 6 mois). Les régler de nouveau si nécessaire.

Cerniere Controllare regolarmente le cerniere (ad es. ogni 6 mesi). Regolarle di nuovo se necessario.

Straps Straps should be regularly checked for tightness (e.g. every six months) and adjusted accordingly if necessary.

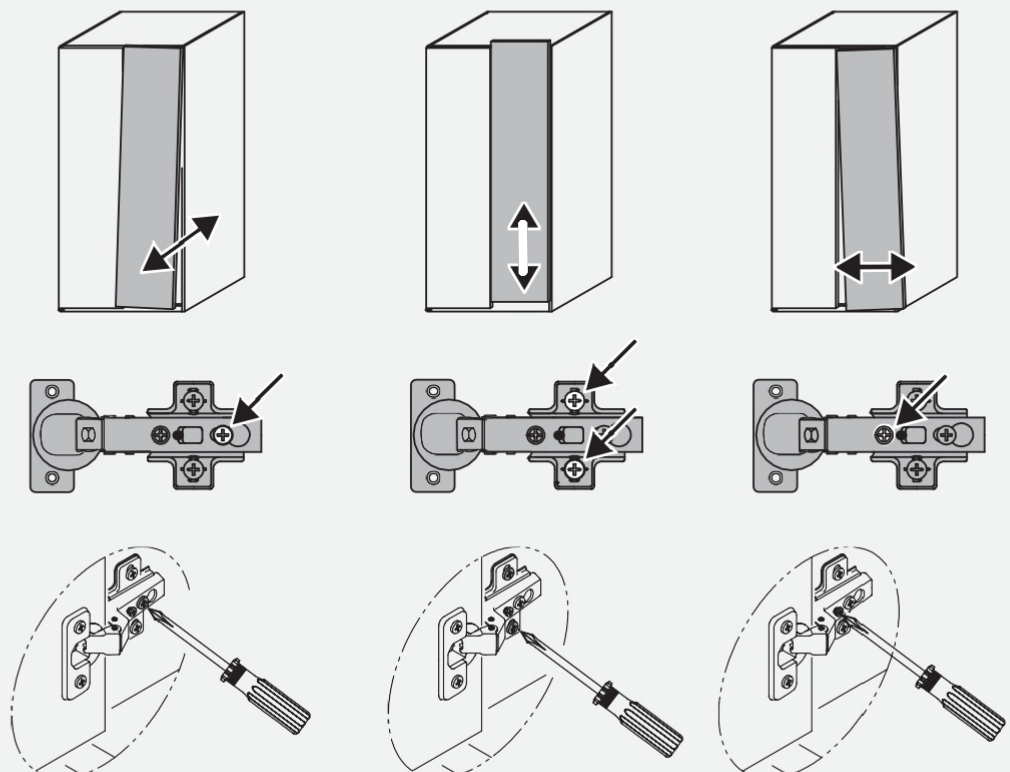

16

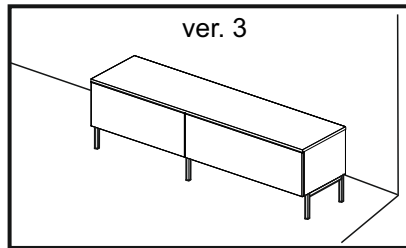
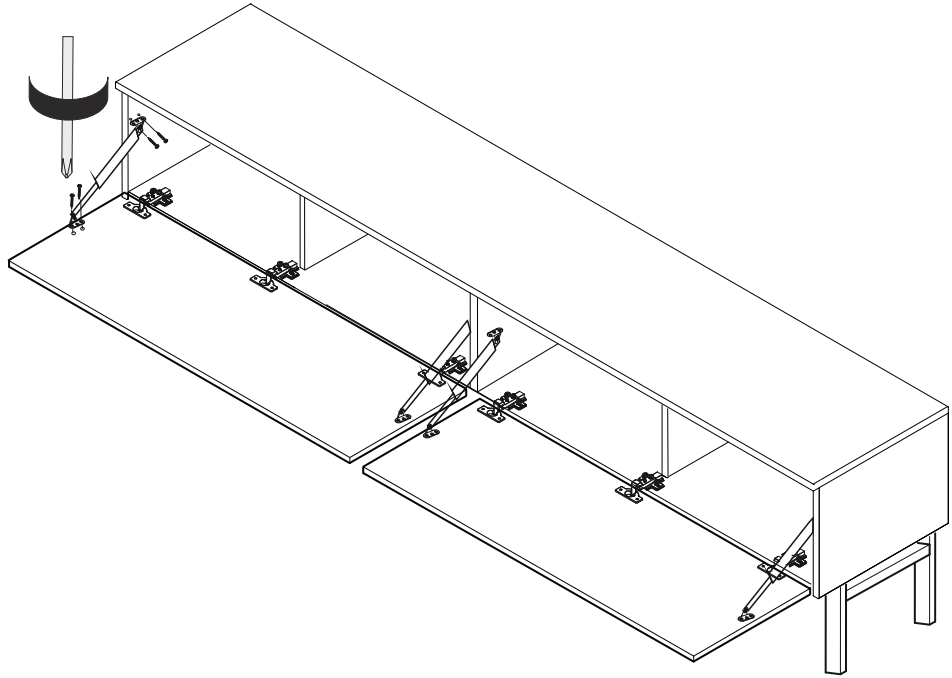
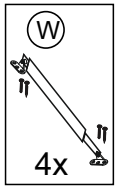

17

