

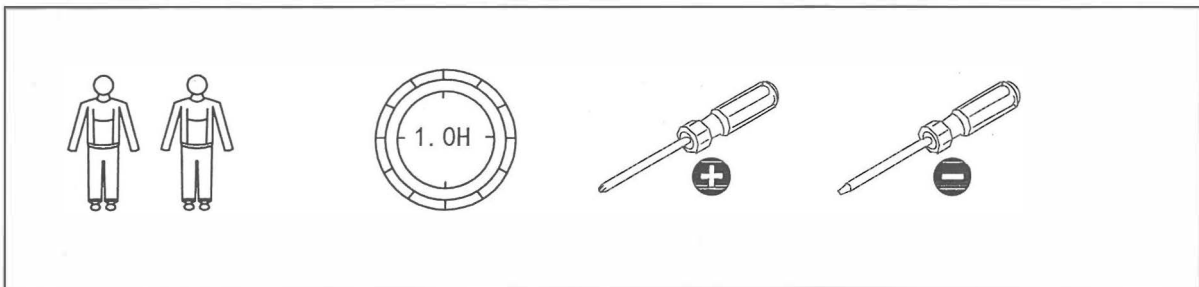

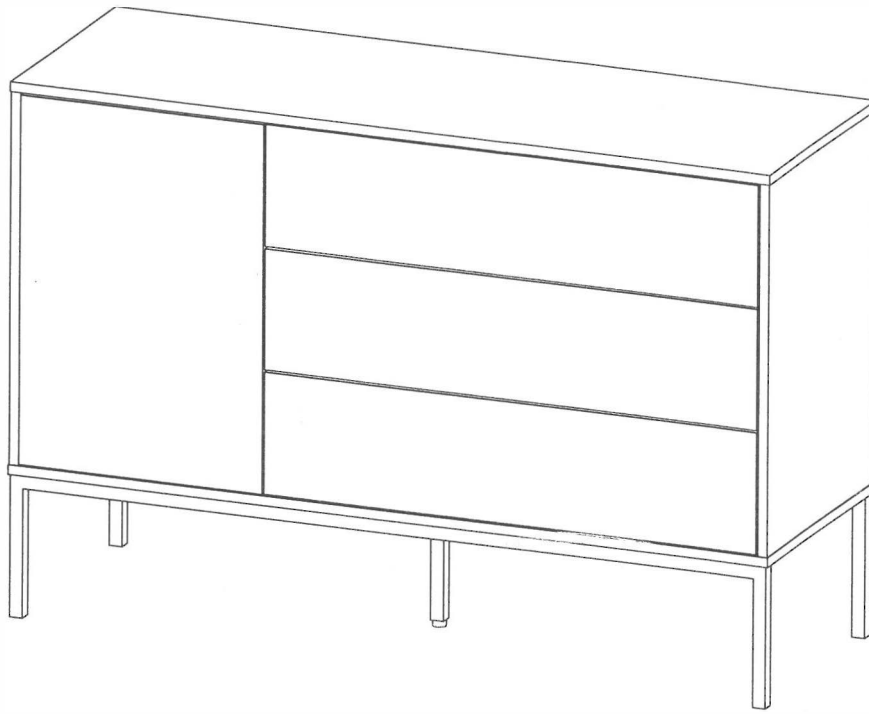

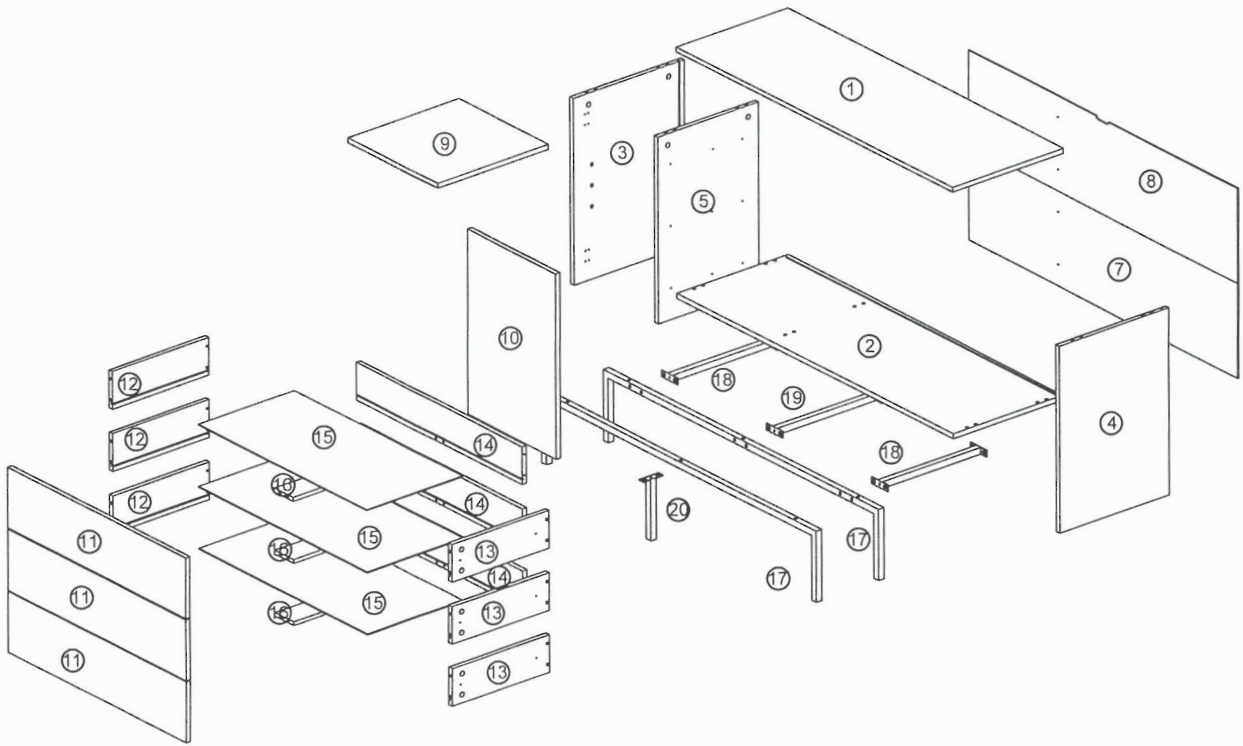

















Seaford





A M6.3×45mm  24PCS	B $\varnothing 15 \times 12 \text{mm}$  18PCS	C $\varnothing 15 \times 10 \text{mm}$  6PCS	D $\varnothing 8 \times 30 \text{mm}$  12PCS	E M7×48mm  6PCS	F M3.5×14mm  46PCS	G L=350mm  6PCS
H FK17  2PCS	I  1PC	J  1PC	K $\varnothing 5 \times 20 \text{mm}$  4PCS	L M6×30mm  6PCS	M M6×15mm  14PCS	N L=150mm  1PC
O $\varnothing 16 / \varnothing 6$  3PCS	P $\varnothing 20 \times 10 / \text{M}6 \times 20$  1PC	Q 9×9×14mm  6PCS	R M3.5×16mm  6PCS	S M4×35mm  18PCS	T M3.5×20mm  4PCS	U M4  1PC

1

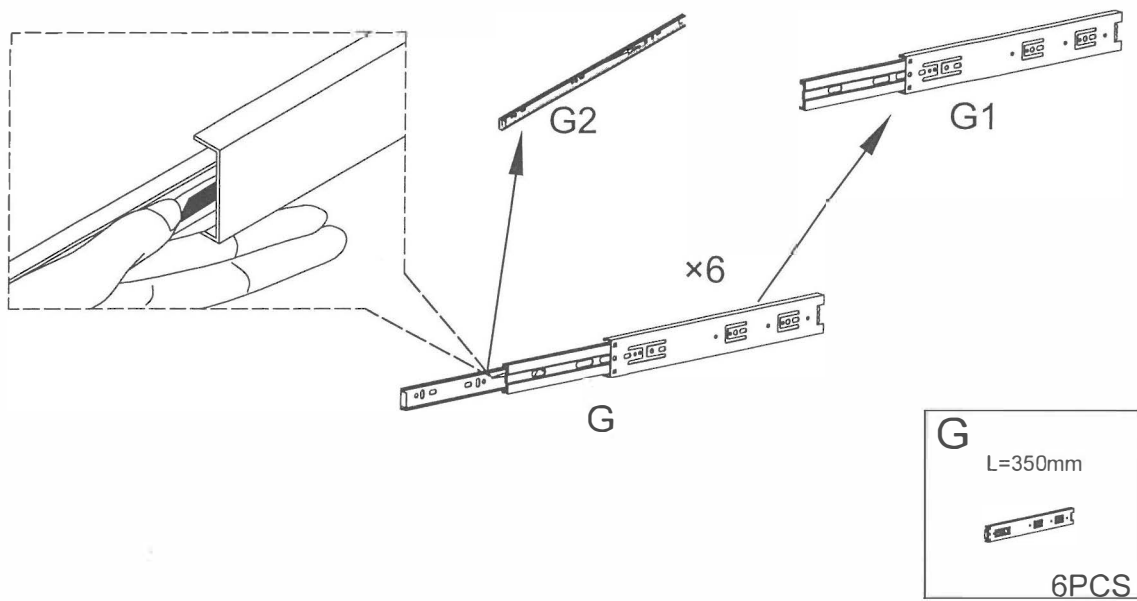

2

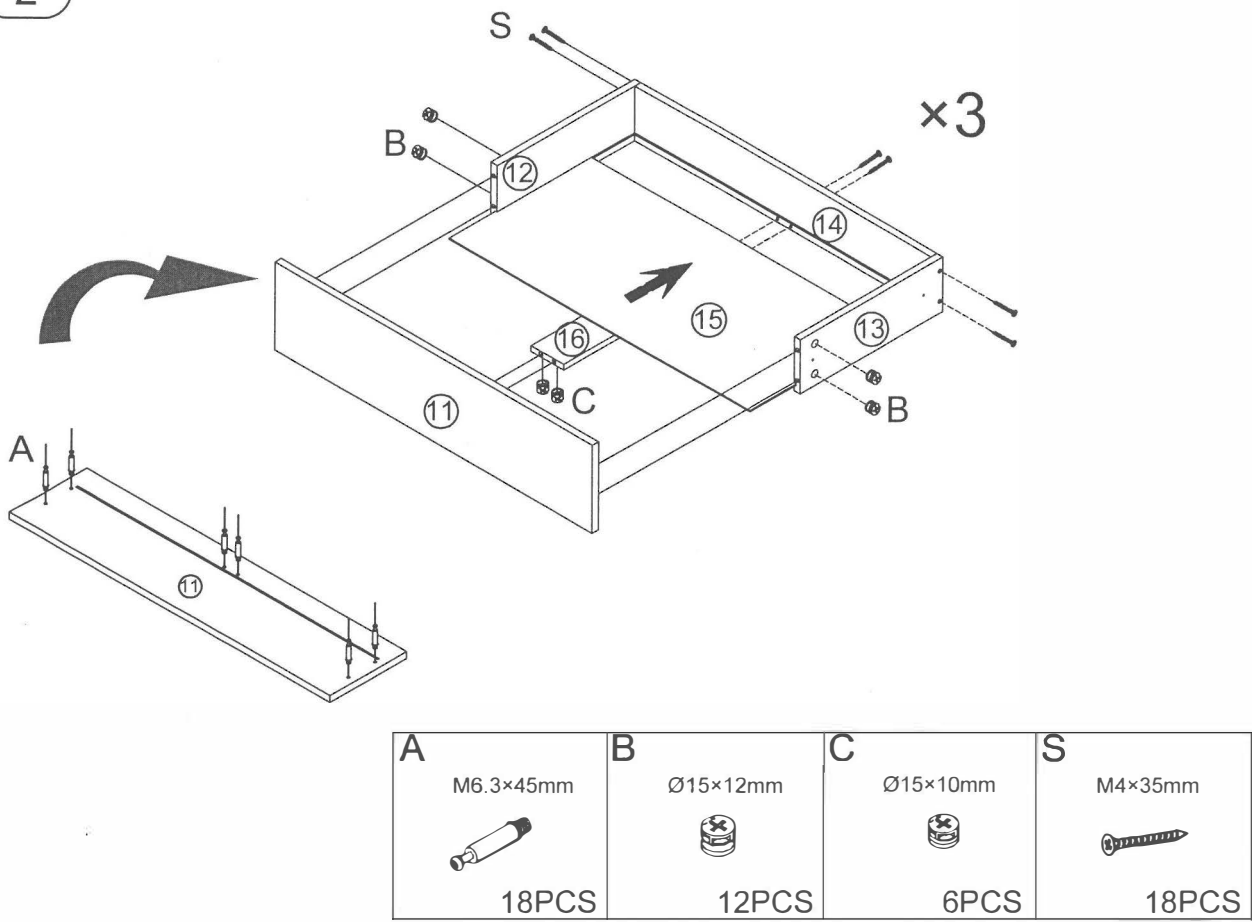



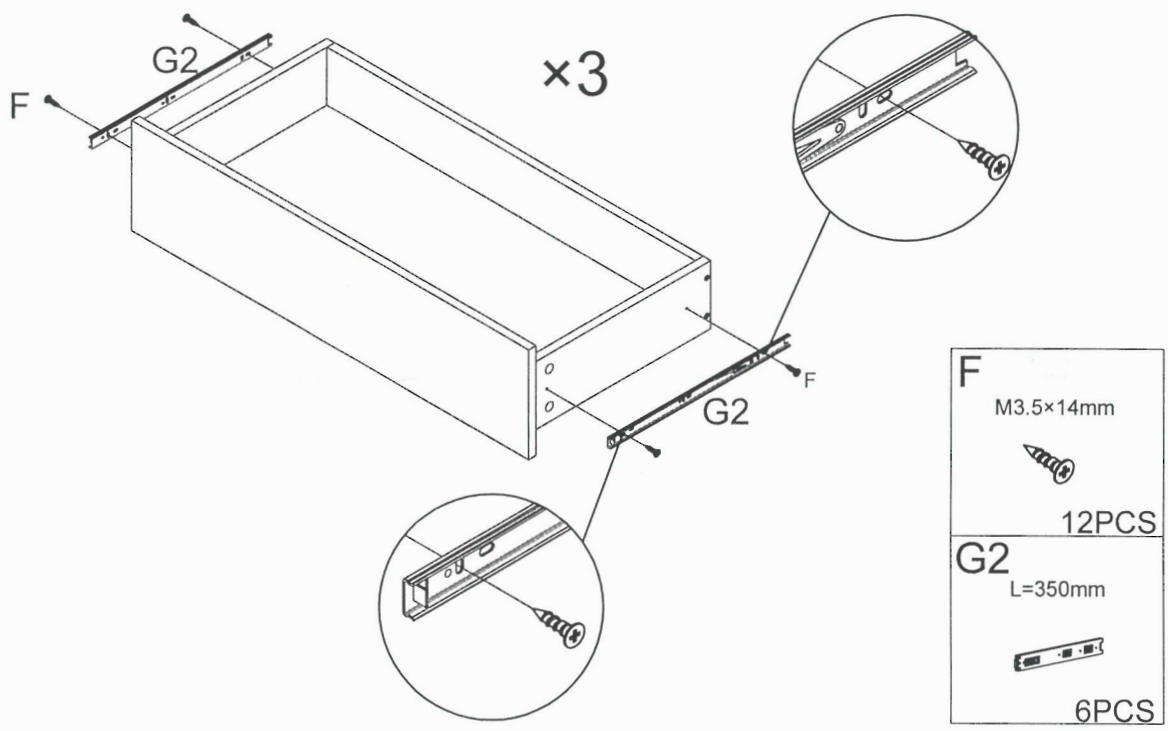

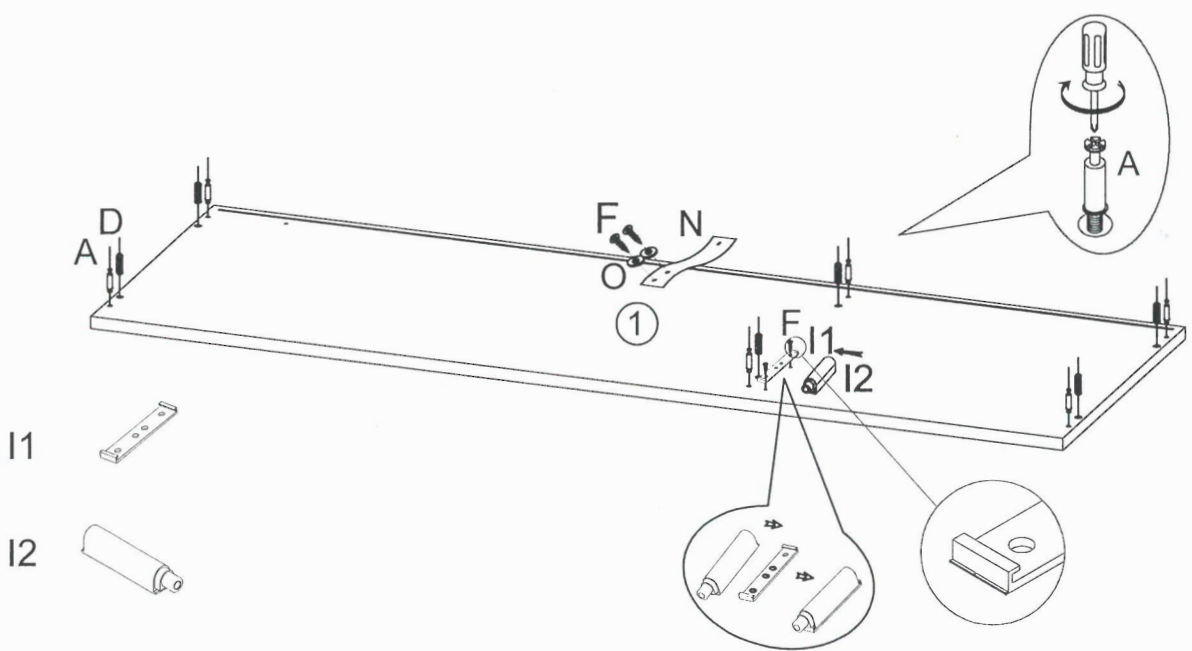

3





4

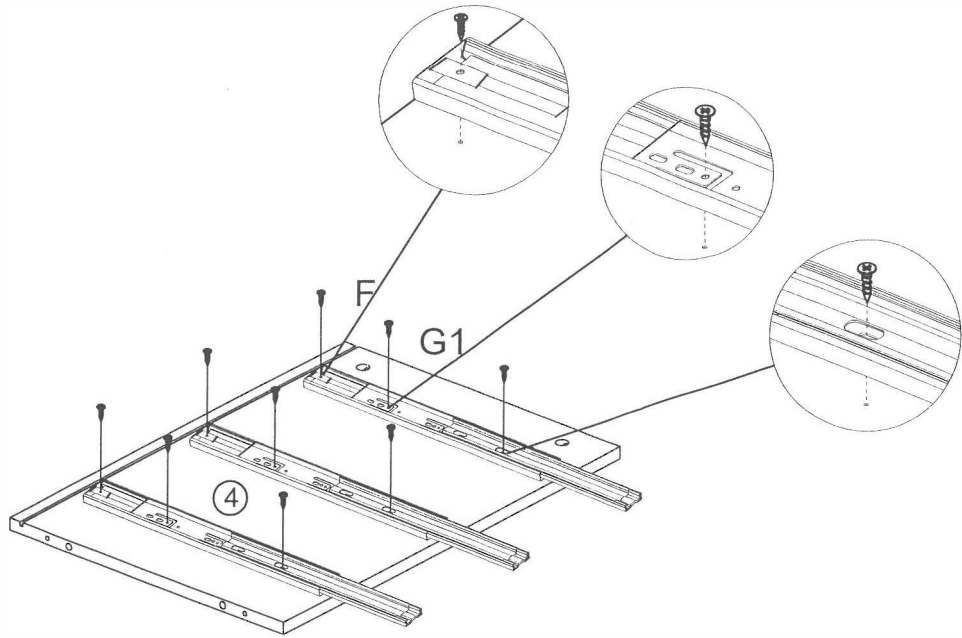

<p>A M6.3x45mm  6PCS</p>	<p>D Ø8x30mm  6PCS</p>	<p>F M3.5x14mm  4PCS</p>	<p>I  1PC</p>	<p>N L=150mm  1PC</p>	<p>O Ø16/Ø6  2PCS</p>
--	--	--	---	---	---

5





F
M3.5×14mm

9PCS

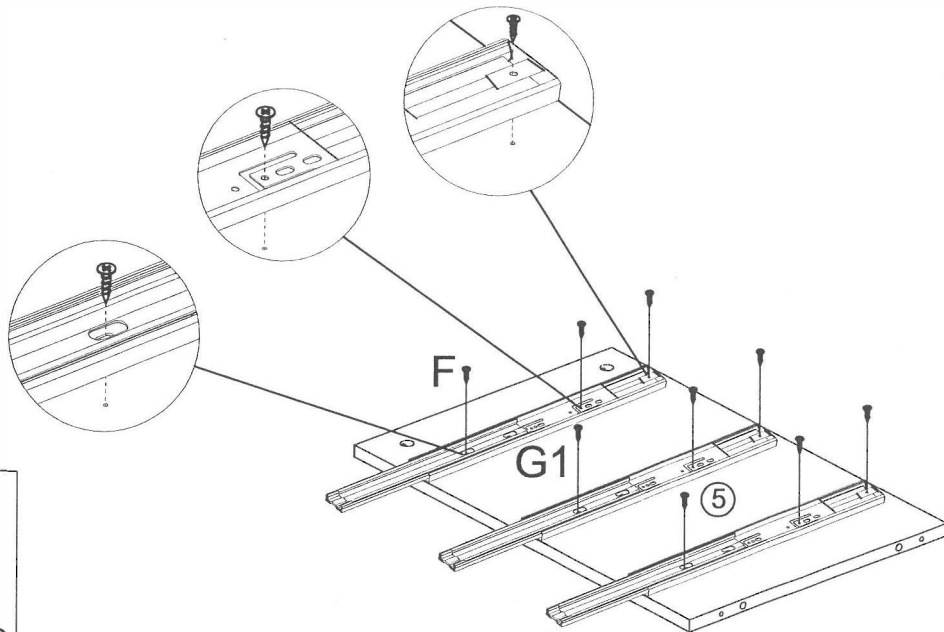
G1
L=350mm

3PCS

6



F
M3.5×14mm

9PCS

G1
L=350mm

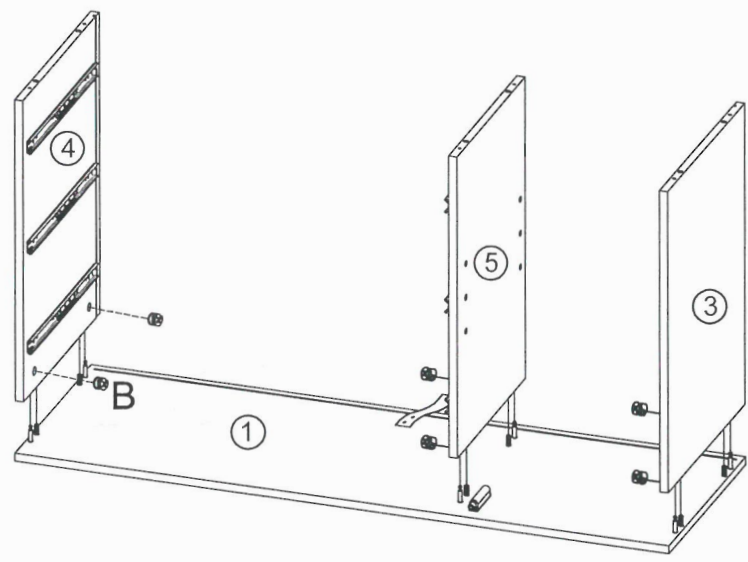
3PCS

7



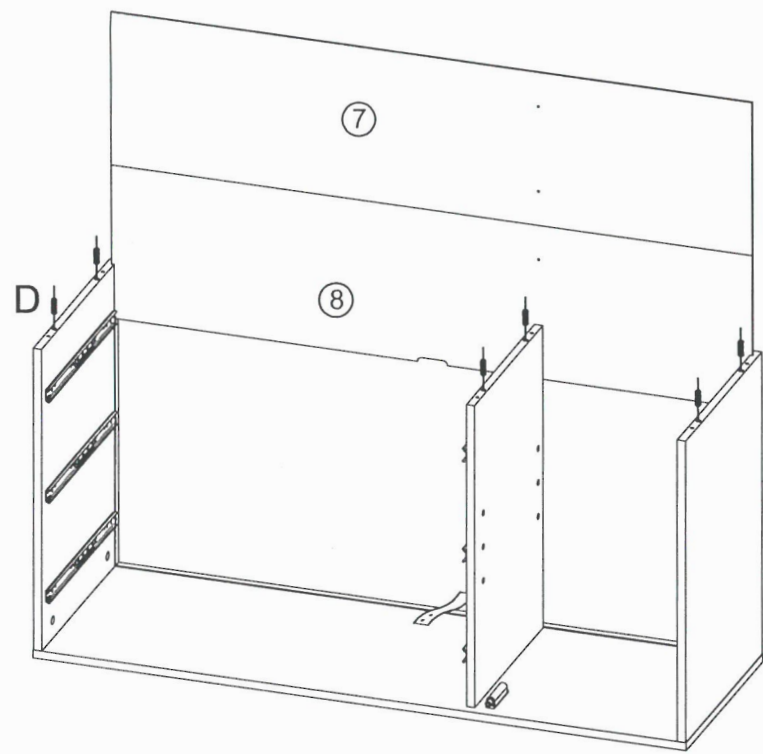

B
Ø15×12mm

6PCS

8





D
Ø8×30mm

6PCS

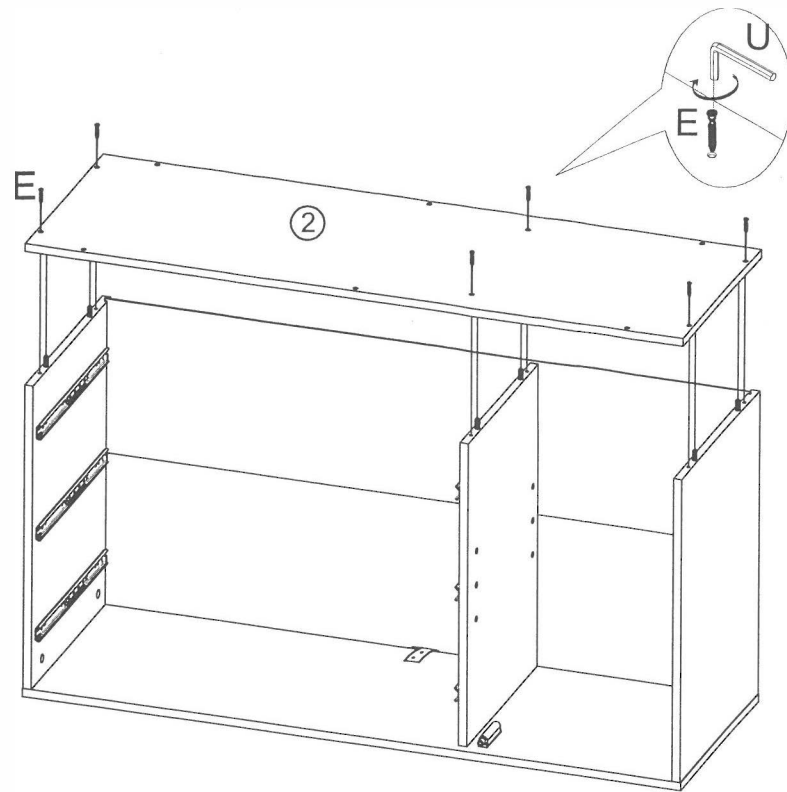
9

E M7×48mm  6PCS	U M4  1PC
--	--



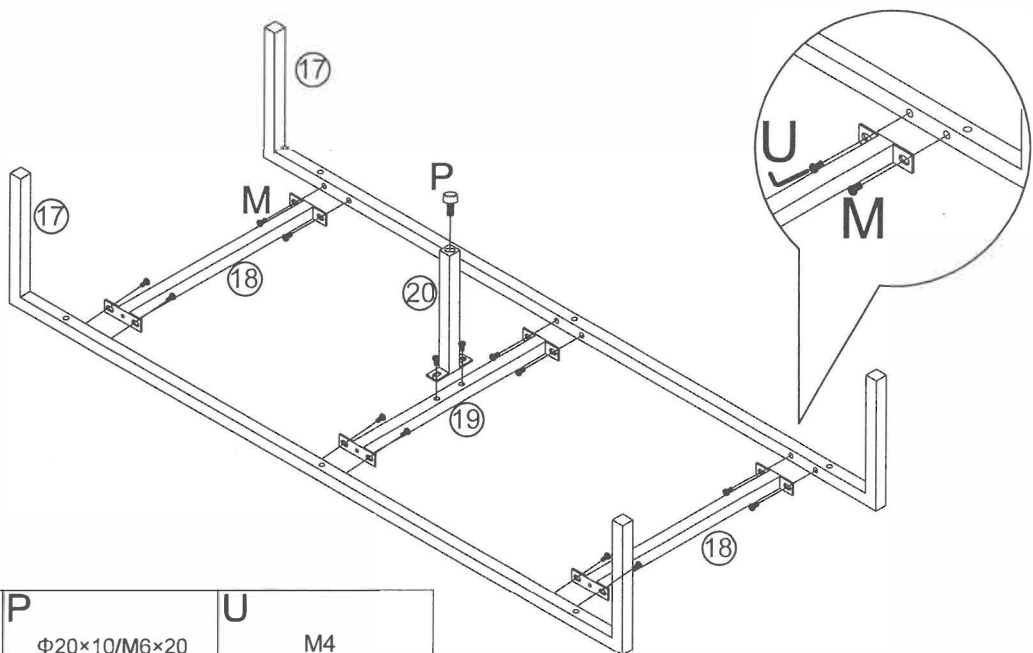

10

M M6×15mm  14PCS	P Φ20×10/M6×20  1PC	U M4  1PC
---	--	--



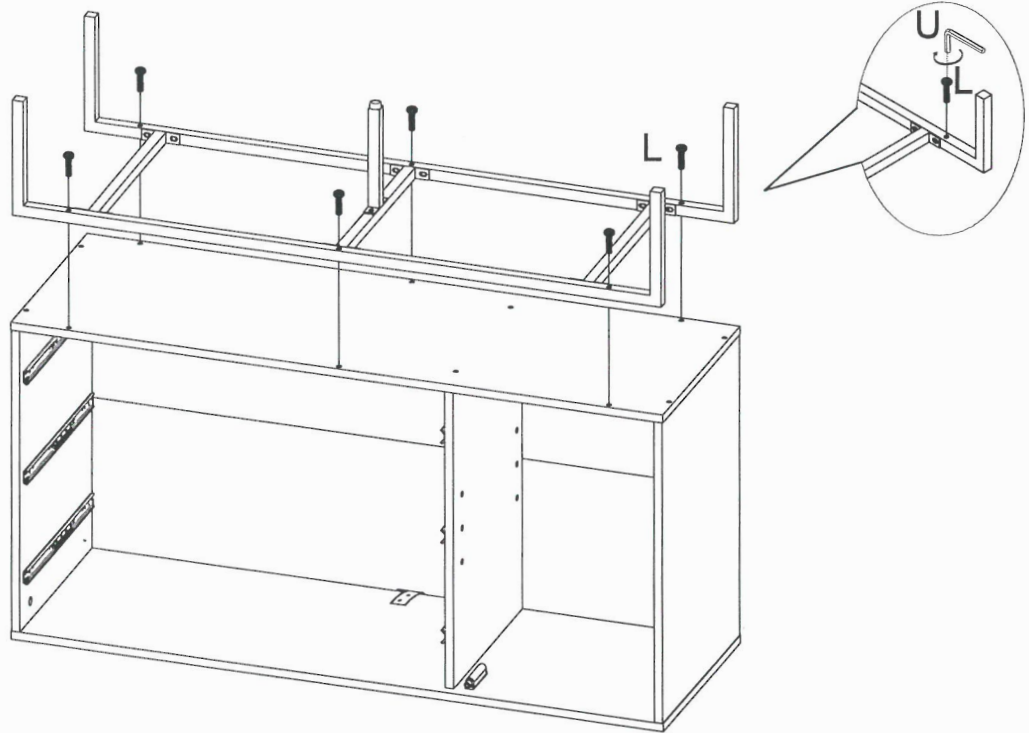

11



L	M6×30mm
	6PCS
U	M4
	1PC

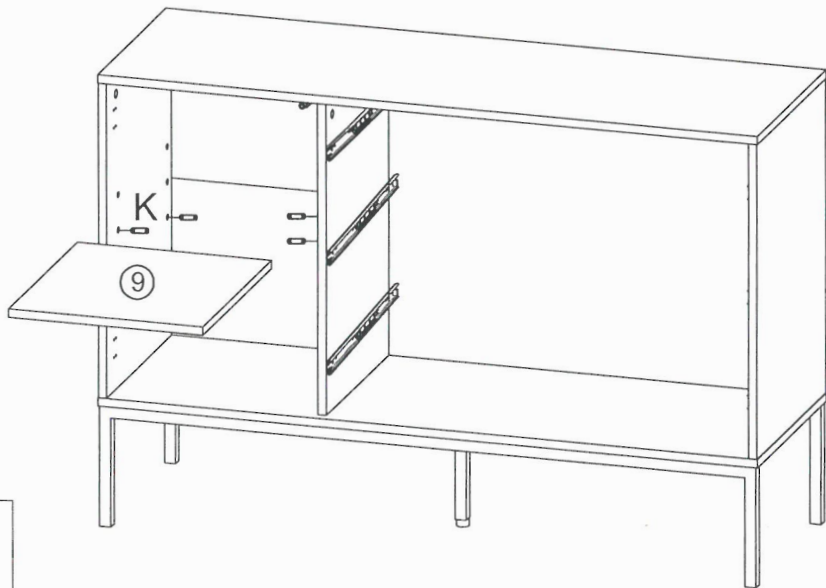

12

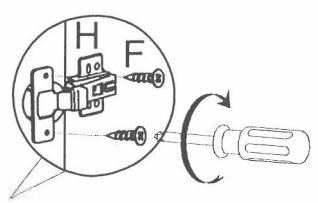
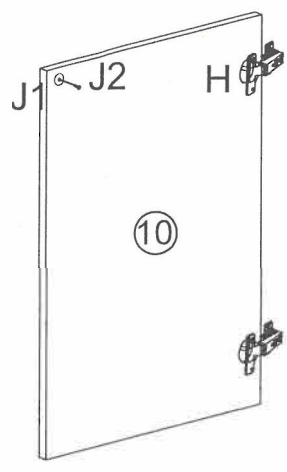
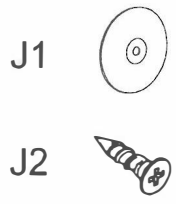

K	M5×20mm
	4PCS

13



F M3.5×14mm  4PCS	H FK17  2PCS	J  1PC
--	---	--

14

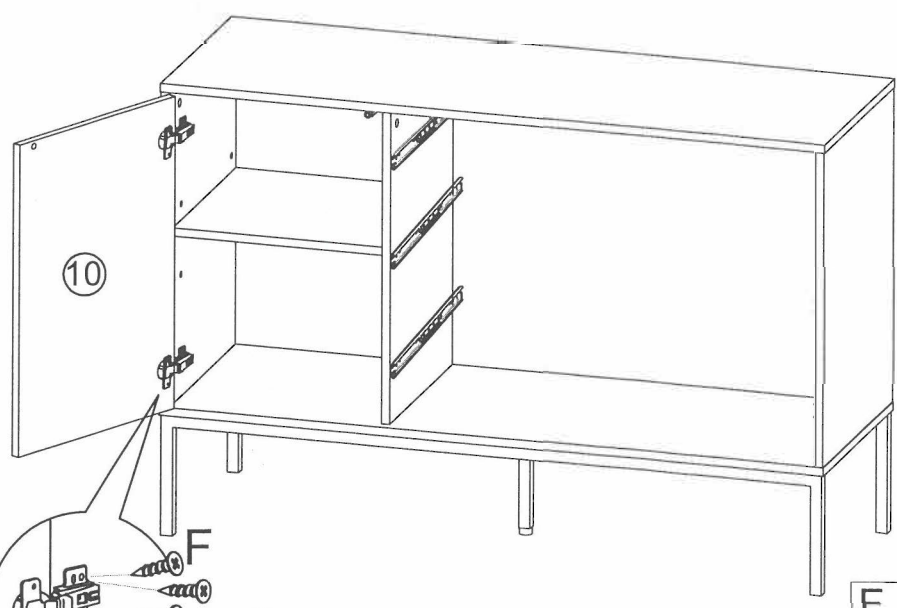

F M3.5×14mm  8PCS
--

15

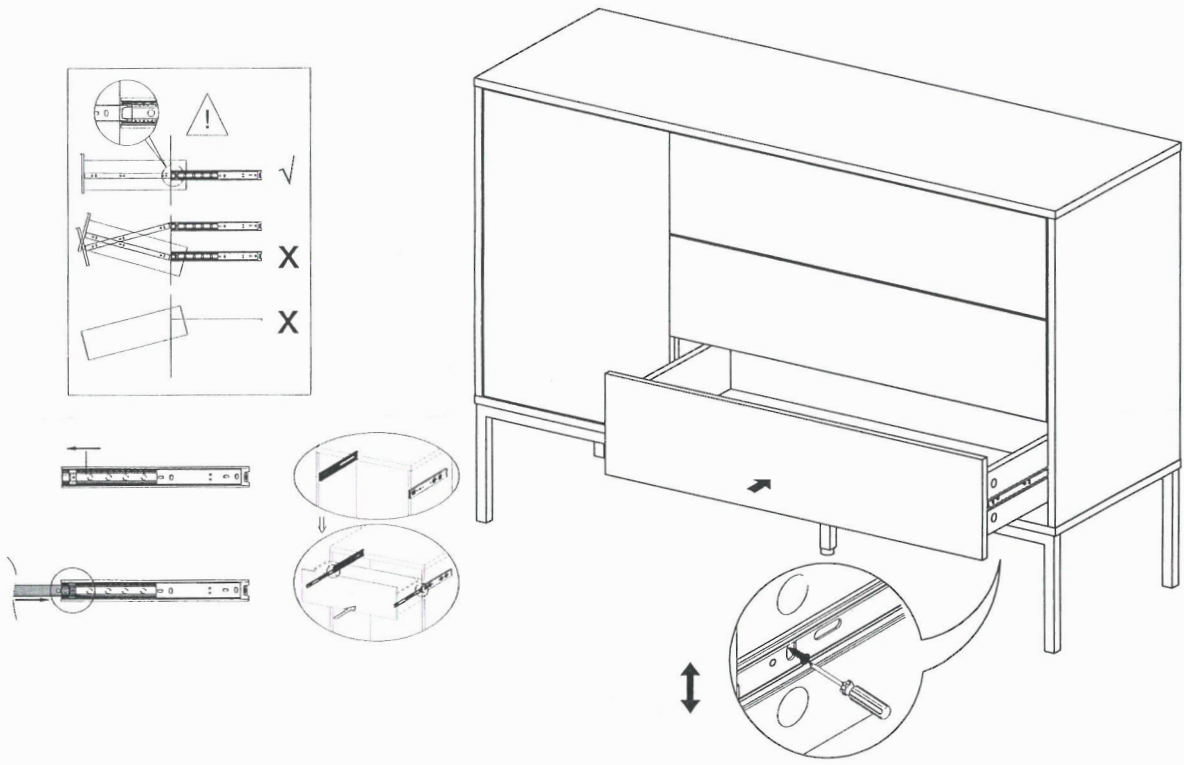

16

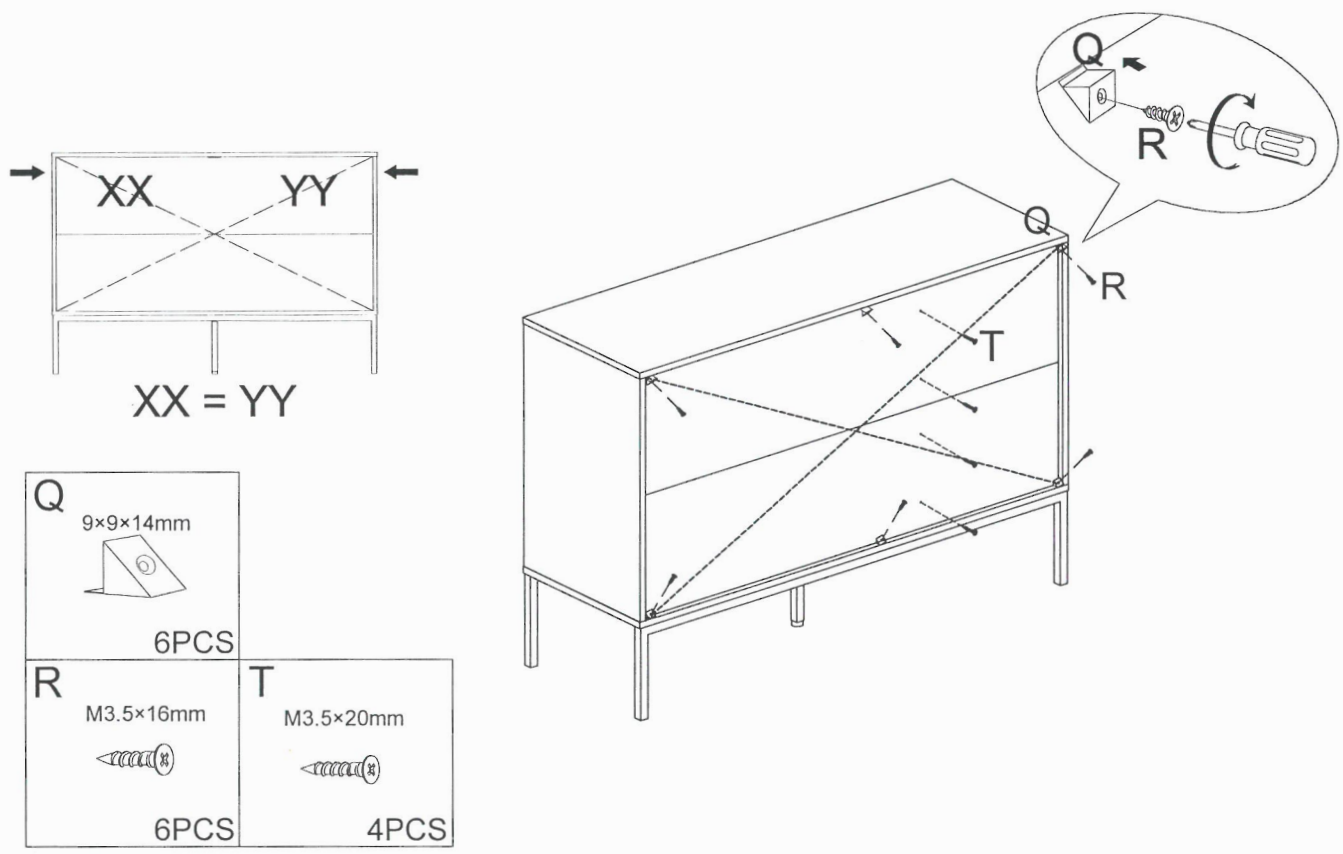

17

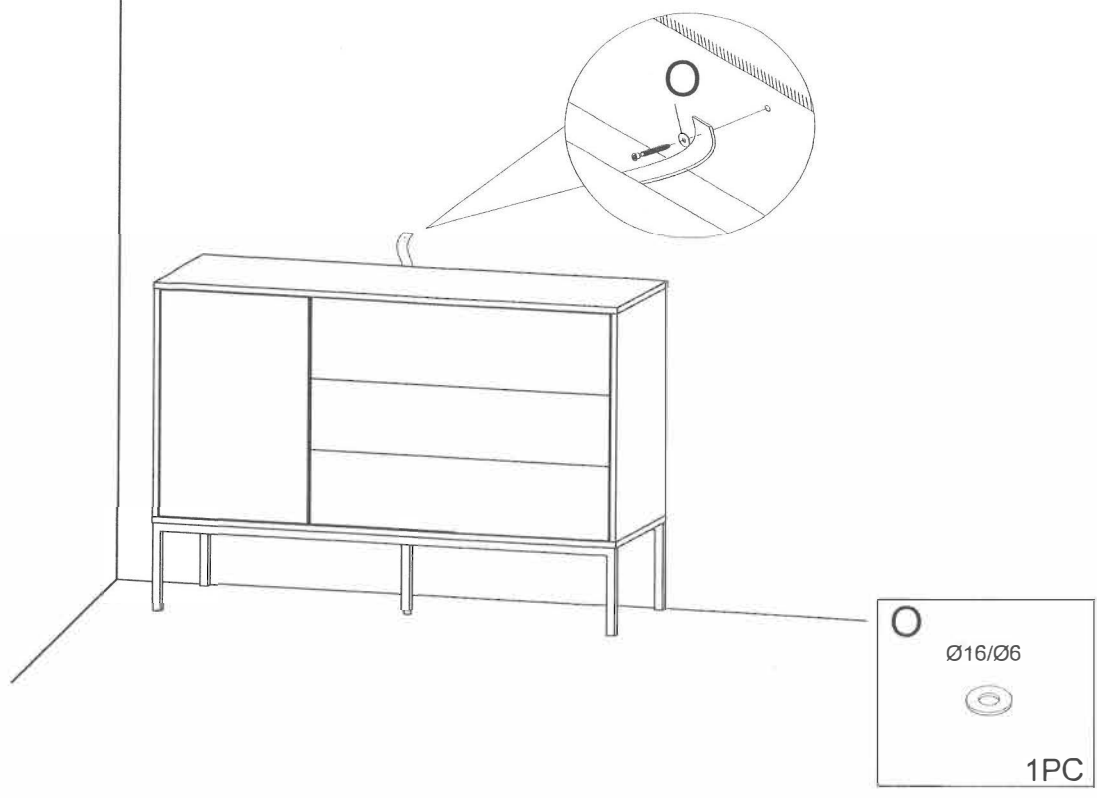

18

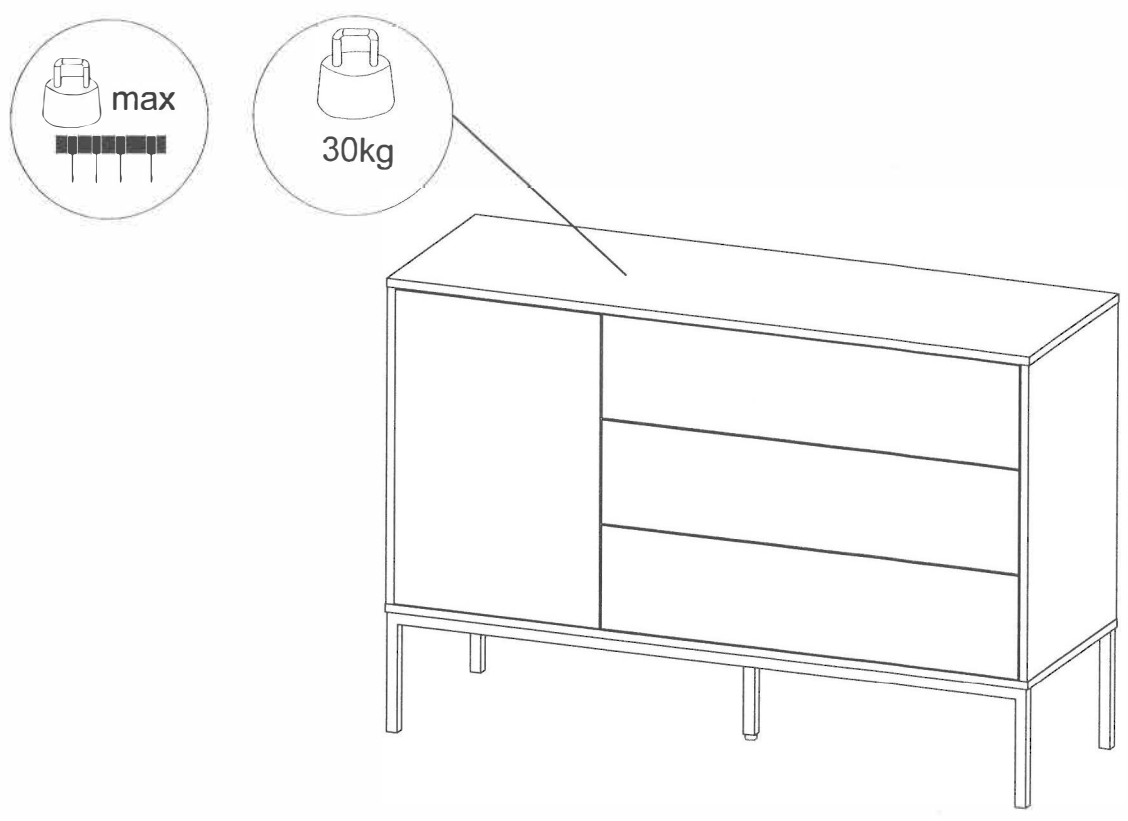

14



TO ADJUST YOUR DOORS TO MAKE THE GAPS MORE EVEN (OPTIONAL).

STEP 14.1
Open the door.

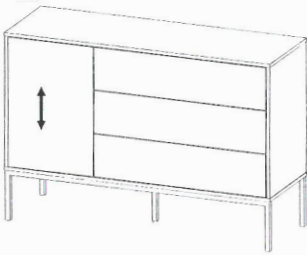
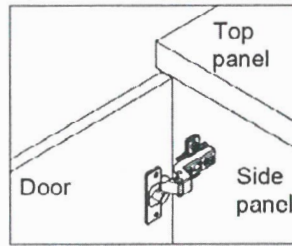

STEP 14.2
Adjust the door panels
upward or downward

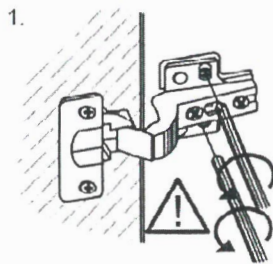

1. Unscrew 2 screws in round holes
Loosen 2 screws in oval holes
a bit.

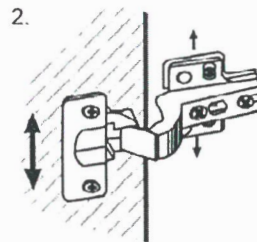

2. MOVE DOOR UPWARD
OR DOWNWARD

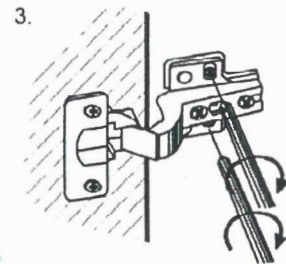

3. Tighten 2 screws in oval holes.
Screw in 2 screws in round holes

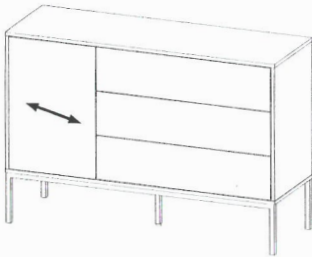

STEP 14.3
Adjust the flush between
door panel and side panel

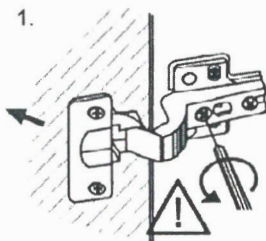

1. MOVE DOOR OUTWARD
by turning this screw
counter-clockwise

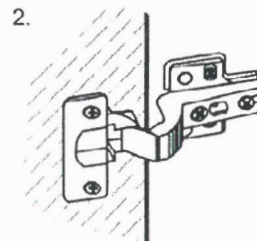

2. KEEP DOOR IN RIGHT
POSITION

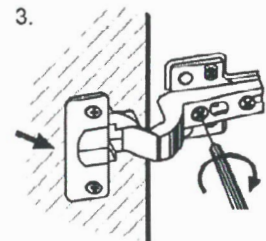

3. MOVE DOOR OUTWARD
by turning this screw
clockwise

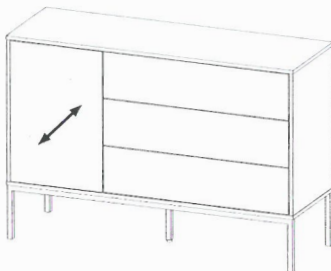

STEP 14.4
Adjust the gap between
door panel and side panel

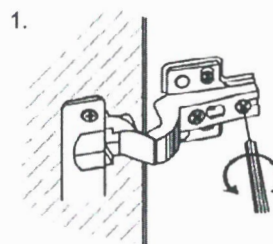

1. Loosen this screw a bit.

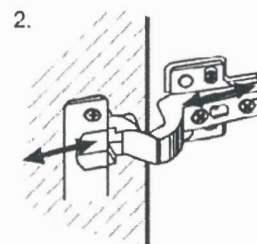

2. MOVE DOOR BACK OR
FORTH

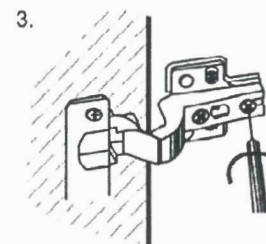

3. Re-tighten this screw.