

54	68	68	54
54	81	81	54
68	81	81	68
81	81	81	81

D Deutsch:
Bitte beachten Sie beim Aufbau unbedingt die Montageanleitung für Ihre Möbel. Der fachkundige Aufbau nach Montageanleitung ist zwingende Garantiebedingung. Bei durch Nichtbeachtung wichtiger Produktinformationen verursachten Folgeschäden wird keine Haftung übernommen. Nur durch eine genaue vertikale und horizontale Ausrichtung des Schrankkörpers ist eine optimale Funktion der Türen, Schubkästen und Sonderausstattungen gewährleistet. Nach dem genauen Ausrichten ist eine Wandmontage aus Sicherheitsgründen, aber auch aus Funktions- und Stabilitätsgründen unbedingt notwendig. Das mitgelieferte Wandbefestigungsmaterial (Dübel, Schrauben) ist ausschließlich für die Befestigung an Beton und/oder festem Mauerwerk geeignet. Bei abweichender Beschaffenheit (z.B. Gipskarton- oder Leichtbauwände) ist entsprechendes Befestigungsmaterial im Fachhandel zu besorgen. Die Demontage Ihrer Möbel erfolgt in umgekehrter Reihenfolge wie die Montage.

GB English:
Please be absolutely certain to follow the installation instructions when assembling your furniture. Technically competent assembly according to the installation instructions is an essential condition of the guarantee. No liability can be accepted for consequential damages caused by failure to heed important product information. Optimum function of the doors, drawers and special equipment is only ensured by exact vertical and horizontal alignment of the unit carcass. Following precise alignment, wall attachment is absolutely necessary for safety reasons as well as function and stability. The wall fixings included in delivery (dowels and screws) are solely suitable for attaching to concrete and/or solid masonry. In case of different characteristics (e.g. plasterboard or lightweight walls), appropriate fixings must be obtained from the specialist trade. The disassembly is performed in reverse order to the assembly.

F Französisch:
Lors du montage de vos meubles, les instructions de montage sont à respecter absolument. Le montage compétent selon les instructions de montage est la condition impérative pour la garantie. Nous déclinons toute responsabilité pour les dommages consécutifs résultant du non-respect des informations importantes sur le produit. Le fonctionnement correct des portes, tiroirs et équipements en option ne peut être garanti que lorsque le corps de l'armoire a été aligné exactement à la verticale et à l'horizontale. Après l'alignement précis il est absolument nécessaire de réaliser le montage mural de l'armoire pour des raisons de sécurité, de bon fonctionnement et de stabilité. Les accessoires de fixation murale compris dans la livraison (chevilles, vis) sont destinés exclusivement à la fixation de l'armoire sur des murs en béton ou des murs solides. En cas de murs de qualité différente (p.ex. mur de plâtre ou mur de construction légère) les éléments de fixation correspondants sont à procurer dans le commerce spécialisé. Le démontage de vos meubles s'effectuera dans l'ordre inverse du montage.

NL Niederländisch:
Volg de montage-instructies voor uw meubels. Een vakkundige montage volgens de montagehandleiding is een verplichte garantievoorwaarde. Er wordt geen aansprakelijkheid aanvaard voor gevolgschade die wordt veroorzaakt door het niet naleven van belangrijke productinformatie. Een optimale werking van de deuren, laden en optionele extra's kan alleen worden gegarandeerd als de kast exact verticaal en horizontaal wordt uitgelijnd. Na een exacte uitlijning is wandmontage absoluut noodzakelijk om veiligheidsredenen, maar ook om functionele en stabiliteitsredenen. Het meegeleverde wandmateriaal (deuvels, schroeven) is alleen geschikt voor bevestiging aan beton en/of massief metselwerk. In geval van afwijkende omstandigheden (bijv. gipsplaat- of lichtbouwwallen) moet het juiste bevestigingsmateriaal bij een vakhandelaar worden aangeschaft. Het demonteren van uw meubelen gaat in omgekeerde volgorde van montage.

SLO Slowenisch:
Pri postavitvi obvezno upoštevajte navodila za montažo pohištva. Strokovna postavitve v skladu z navodili za montažo je pogoj za garancijo. Za škodo, ki je posledica neupoštevanja pomembnih informacij o izdelku, ne prevzemamo odgovornosti. Najboljše odpiranje in zapiranje vrat, predalov in opreme po meri je zagotovljeno le z natančno navpično in vodoravno poravnavo korpusa omar. Po natančni poravnavi je treba omaro zaradi varnosti, funkcionalnosti in stabilnosti obvezno pritrčiti na steno. Priloženi material za pritrčitev na steno (vložki, vijaki) je primeren izključno za pritrčitev omar na beton in/ali trden zid. Pri drugačnih konstrukcijah (npr. stene iz mavčnih ali lahkih gradbenih plošč) je treba priskrbeti ustrezen material za pritrčitev, ki je na voljo v specializiranih prodajalnah. Demontaža pohištva poteka v obratnem vrstnem redu montaže.

HR Kroatisch:
Priilikom sastavljanja obavezno obratite pozornost na upute za montažu vašeg namještaja. Stručno sastavljanje u skladu s uputama za montažu obvezni je jamstveni uvjet. U slučaju posljednjih šteta nastalih zbog nepridržavanja važnih informacija o proizvodu ne preuzimamo jamstvo. Samo preciznim okomitim i vodoravnim poravnavanjem tijela ormara zajamčena je optimalna funkcija vrata, ladica i posebne opreme. Nakon preciznog poravnavanja obvezna je montaža na zid ne samo zbog sigurnosti, nego i zbog funkcije i stabilnosti. Isporučeni materijali za pričvršćivanje na zid (pričvršnice, vijci) isključivo su prikladni za montažu na beton i/ili čvrsti zid. U slučaju svojstva koja odstupaju (npr. zidovi od gipsanog kartona, lagani pregradni zidovi) potrebno je nabaviti pričvršni materijal u specijaliziranoj trgovini. Demontaža namještaja vrši se obrnutim redoslijedom od montaže.



CZ Tschechisch:
Při skládání bezpodmínečně dodržujte návod na montáž vašeho nábytku. Odborné poskládání podle návodu na montáž je nutnou záruční podmínkou. Při následných škodách způsobených nedodržením důležitých informací o výrobku nepřebíráme žádné ručení. Optimální funkce dveří, zásuvek a zvláštních výbav je zaručena pouze prostřednictvím přesného vertikálního a horizontálního vyrovnání. Po přesném vyrovnání je z bezpečnostních důvodů, ale také z funkčních důvodů a důvodů stability, bezpodmínečně nutná montáž na stěnu. Priložený materiál pro upevnění na zeď (přichytky, šrouby) je vhodný výhradně pro upevnění do betonu a / nebo pevného zdiva. Při odlišné vlastnosti (např. stěny ze sádkokartonu nebo lehké montované stěny) si musíte příslušný upevňovací materiál zakoupit ve specializované prodejně. Demontáž nábytku se provádí v opačném pořadí než montáž.







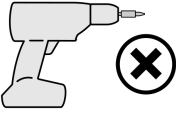
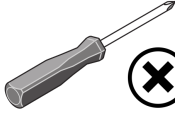
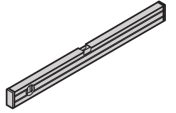
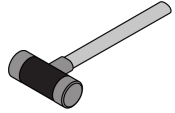
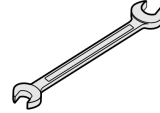

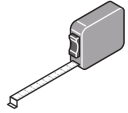
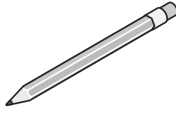
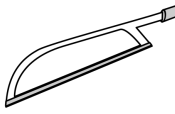

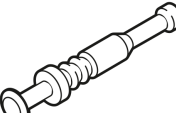
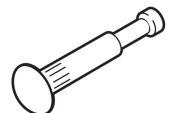

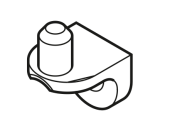
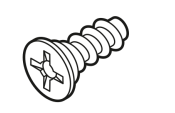

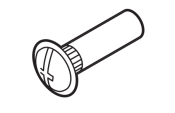

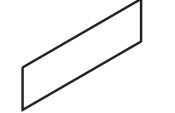

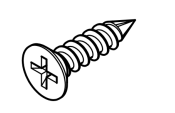
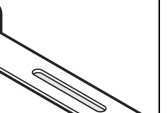
HU Ungarisch:
Kérjük, a felépítésnél okvetlen vegye figyelembe a bútor szerelési útmutatóját. A szerelési útmutató alapján történő szakszerű felépítés a garancia elengedhetetlen feltétele. Fontos termékinformáció figyelmen kívül hagyásából eredő károkért nem vállalunk felelősséget. Csak a szekrény keretének pontos függőleges és vízszintes kialakítása biztosítja az ajtók, fiókok és az egyéb felszerelések optimális működését. A pontos kialakítás a falaszerelésnél is elengedhetetlen biztonsági okokból, valamint a funkció és a stabilitás miatt is. A szállítmány részét képező, a falaszerelés célját szolgáló eszközök (tiplik, csavarok) kizárólag a betonfalra vagy szilárd falazatra történő szerelésre alkalmasak. Eltérő tulajdonság esetén (pl. gipszkartonból vagy könnyű elemből készült fal) szerezze be a szakkereskedelemből a megfelelő rögzítőanyagokat. A bútorok szétszerelése az összeszerelés fordított sorrendjében történik.

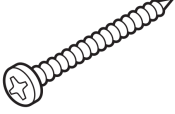
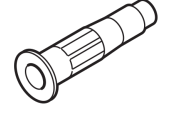

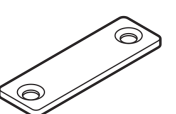
RO Rumänisch:
Vă rugăm ca la montare să respectați neapărat instrucțiunile de montaj ale mobilei dvs. Montarea corectă din punct de vedere tehnic, în conformitate cu instrucțiunile de montaj, este o condiție obligatorie pentru acordarea garanției. La deteriorări produse ca urmare a nerespectării unor informații importante privind produsul, nu se asumă nicio responsabilitate contractuală. Numai printr-o poziționare verticală și orizontală exactă a corpului dulapului se asigură o funcționare optimă a ușilor, sertarelor și accesorilor speciale. După realizarea poziționării exacte, este absolut necesară o fixare de perete, atât din motive de siguranță, cât și din motive funcționale și de stabilitate. Materialul livrat pentru montajul de perete (dubluri, suruburi) este adecvat exclusiv pentru fixare pe beton și/sau zidărie stabilă. În caz de structură diferită (de ex. gips-carton sau zid din materiale ușoare) trebuie procurat material de fixare corespunzător din comerțul de specialitate. Demontarea mobilierului se efectuează în ordinea inversă a asamblării.

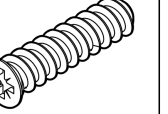
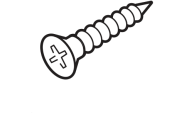
SK Slowakisch:
Pri skládání bezpodmínečně dodržte návod na montáž vašho nábytku. Odborné poskládanie podľa návodu na montáž je nutnou záručnou podmienkou. Pri nasledujúcich škodách spôsobených nedodržením dôležitých informácií o výrobku neprevzeme žiadne ručenie. Optimálna funkcia dverí, zásuviek a zvláštnych výbav je zaručená iba prostredníctvom presného vertikálneho a horizontálneho vyrovnania. Po presnom vyrovnaní je z bezpečnostných dôvodov, ale aj z funkčných dôvodov a dôvodov stability bezpodmínečne potrebná montáž o stenu. Priložený materiál na upevnenie o stenu (príchytky, skrutky) je vhodný výhradne na upevnenie do betónu a/alebo pevného muriva. Pri odlišnej vlastnosti (napr. steny zo sadrokartónu alebo ľahké montované steny) si musíte príslušný upevňovací materiál zakúpiť v špecializovanej predajni. Demontáž nábytku sa vykonáva v opačnom poradí ako montáž.

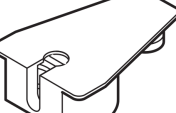
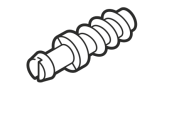
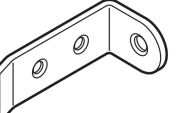
SR Serbisch:
Molimo Vas da priilikom montaže obavezno pratite uputstva za montažu nameštaja. Profesionalna montaža prema uputstvu za montažu je obavezan predušlov garancije. Ne preuzimamo odgovornost u slučaju posledične štete nastale nepoštovanjem važnih informacija o proizvodu. Optimalna funkcija vrata, fioka i posebne opreme može se garantovati samo u slučaju preciznog vertikalnog i horizontalnog poravnanja tela ormara. Nakon preciznog poravnanja, važno je, iz bezbednosnih razloga, ali i iz razloga funkcionalnosti i stabilnosti, obavezno izvršiti zidnu montažu. Isporučeni materijal za pričvršćivanje na zid (tipli, šrafovi) služi isključivo za pričvršćivanje na beton i/ili zid od cigle. Kod drugačijih svojstava (npr. zidovi od gipsanih ploča ili drugi lagani zidovi) mora se obezbediti odgovarajući materijal za pričvršćivanje od specijalizovanih distributera. Demontaža nameštaja se vrši obrnutim redosledom od montaže.

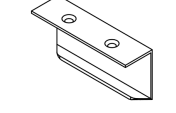
					 Ø 3 mm Ø 8 mm	
				10		

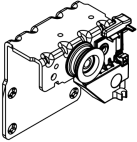
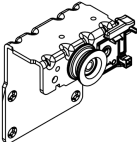
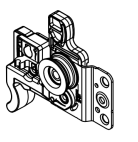
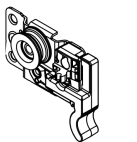
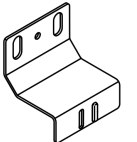
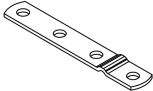
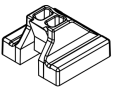
 Ø 5 x 35 mm 25059 18x	 Ø 5 x 27 mm 25062 8x	 26565 16x	 Ø 6,3 x 10,5 mm 29691 16x	 Ø 3 mm 46943 32x	 Ø 4,2 x 10 mm 09126 48x	 Ø 3 mm 09125 8x
 Ø 3,5 x 15 mm 17616 14x	 Ø 5 x 15 mm 22681 12x	 Ø M4 x 8 mm 28054 12x	 74 mm x 26 mm 01621 3x	 Ø 6,3 x 13 mm 26304 95x	 Ø 3,5 x 15 mm 65989 2x	 30616 2x
 Ø 4 x 13 mm 23668 4x	 Ø 5 x 50 mm 22844 2x	 Ø 8 x 51 mm 31354 2x	 Ø 3,5 x 13 mm 25305 20x	 68228 8x	 Ø 6,3 x 9 mm 10083 32x	 Ø 6,3 x 25 mm 21066 32x
 Ø 3,5 x 15 mm 25934 32x	 Ø 5 x 30 mm 25418 6x	 36394 16x	 Ø 5 x 23 mm 17971 4x	 12011 4x	 30617 16x	 Ø 5 mm 75218 4x
 92319 4x						

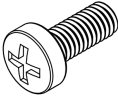
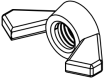
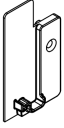
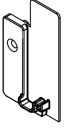
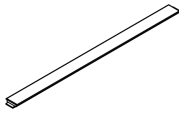
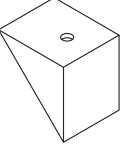
 95594 1x	 93647 1x	 93498 1x	 93497 1x	 34649 2x	 30973 12x	 93252 2x
 93253 2x	 Ø M5 x 12 mm 93255 2x	 Ø M5 93256 2x	 93033 1x	 93034 1x	 93249 2x	 14112 4x

1.

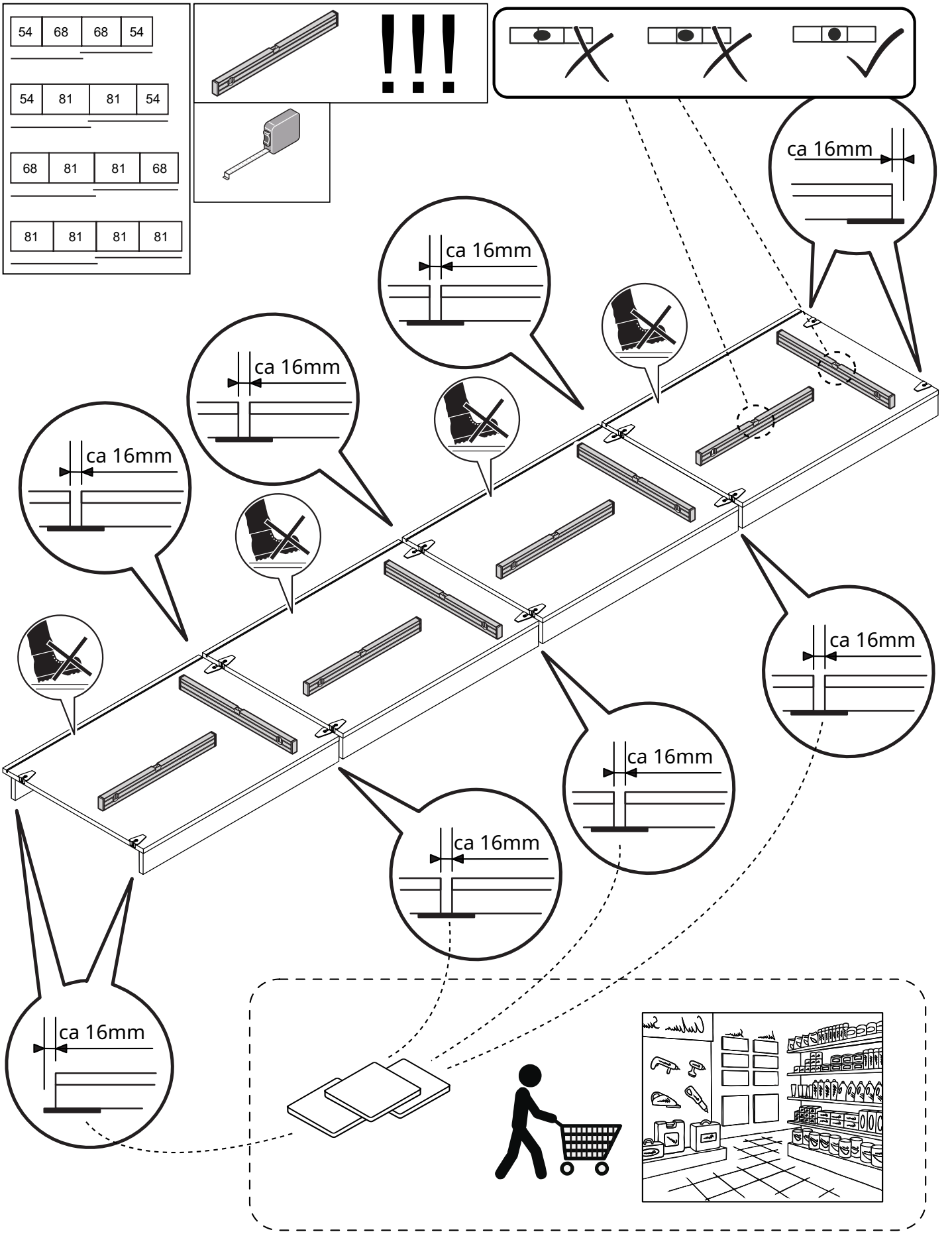

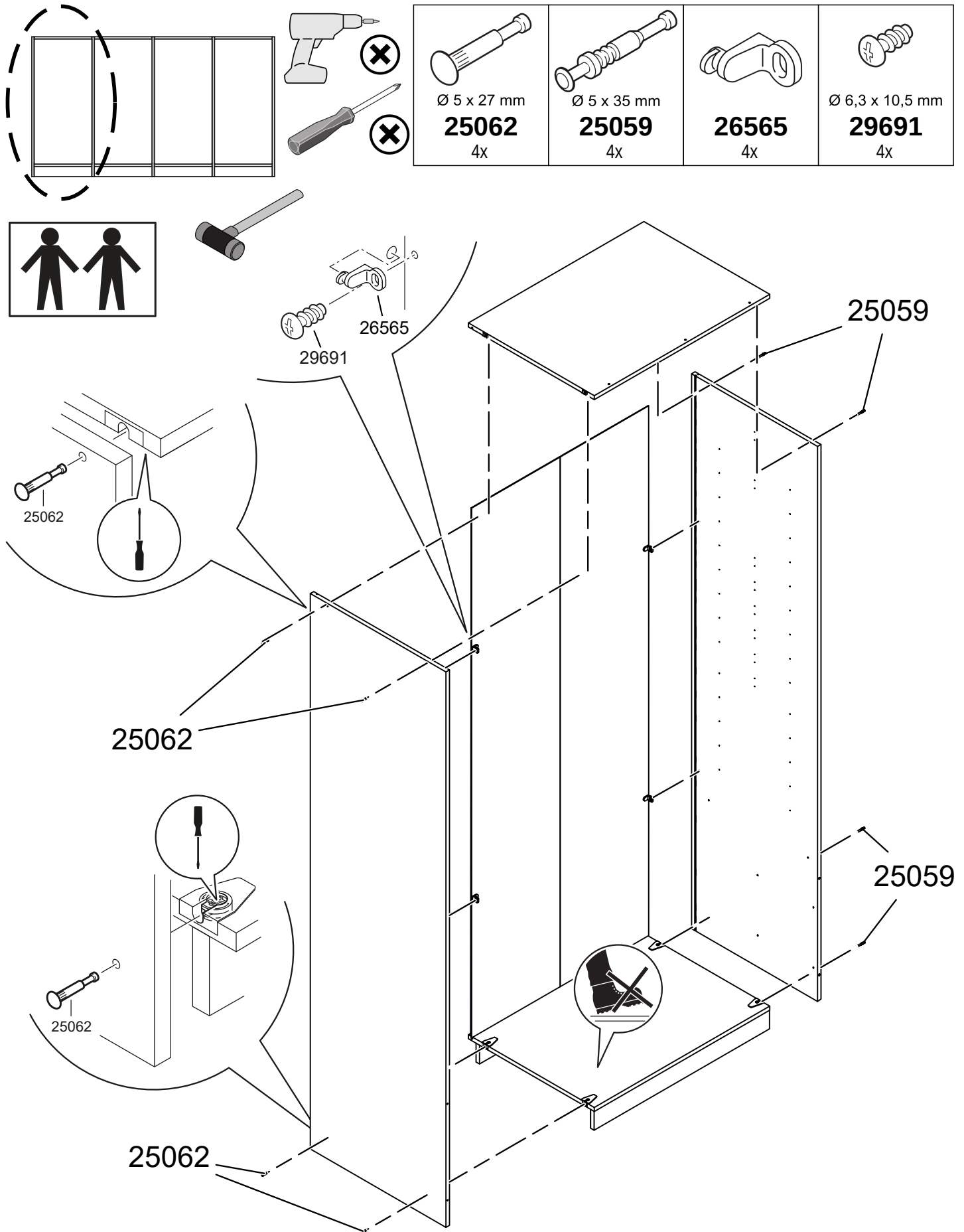

2.1

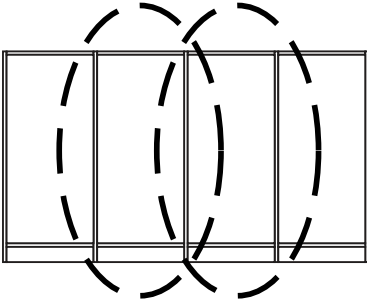

2.2

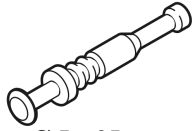

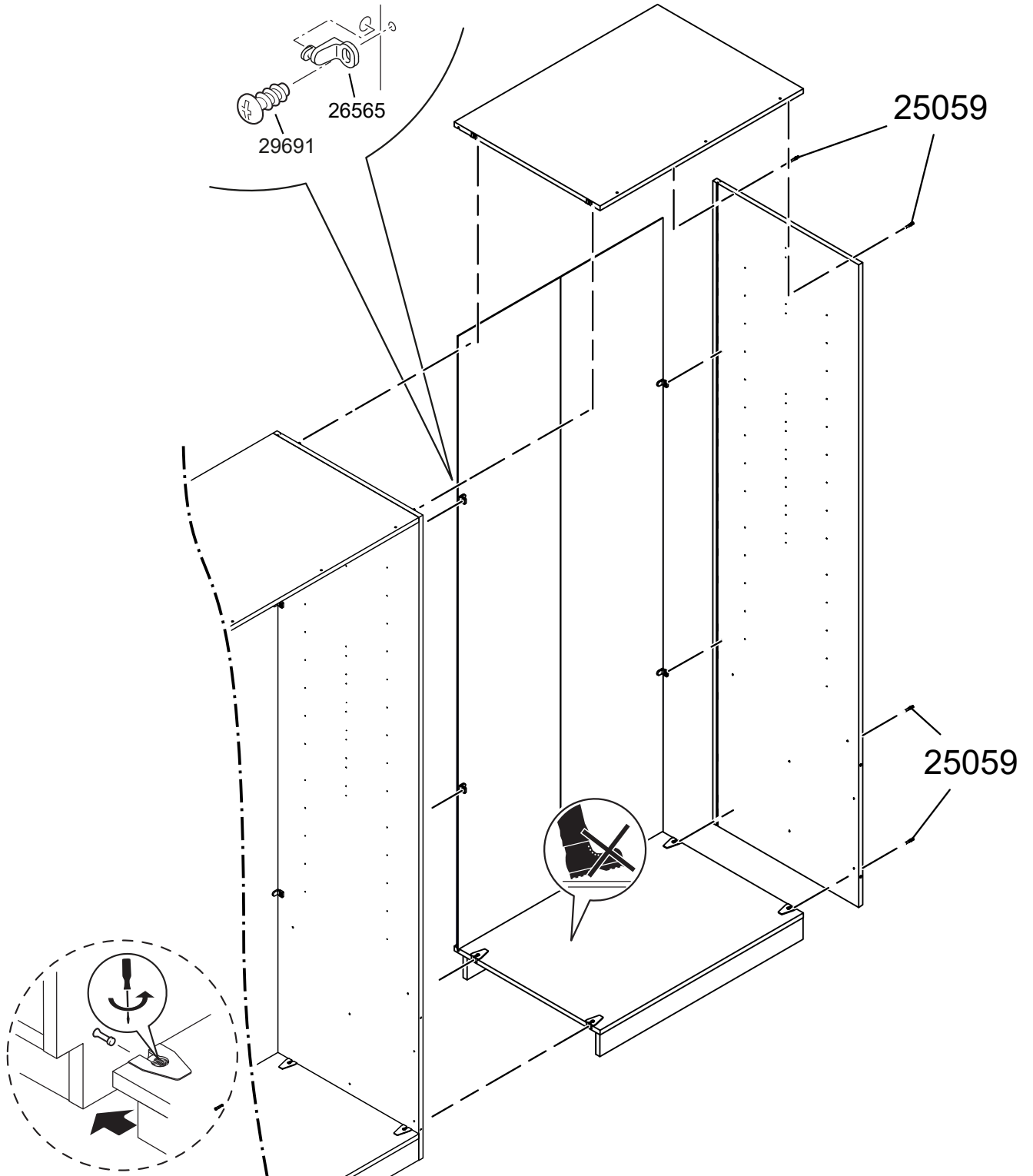

 Ø 5 x 35 mm 25059 4x	 26565 4x	 Ø 6,3 x 10,5 mm 29691 4x
---	---	--

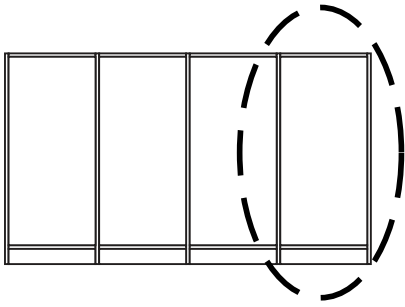

2.3

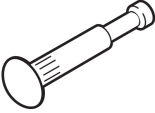

 Ø 5 x 27 mm 25062 4x	 26565 4x	 Ø 6,3 x 10,5 mm 29691 4x
---	---	--

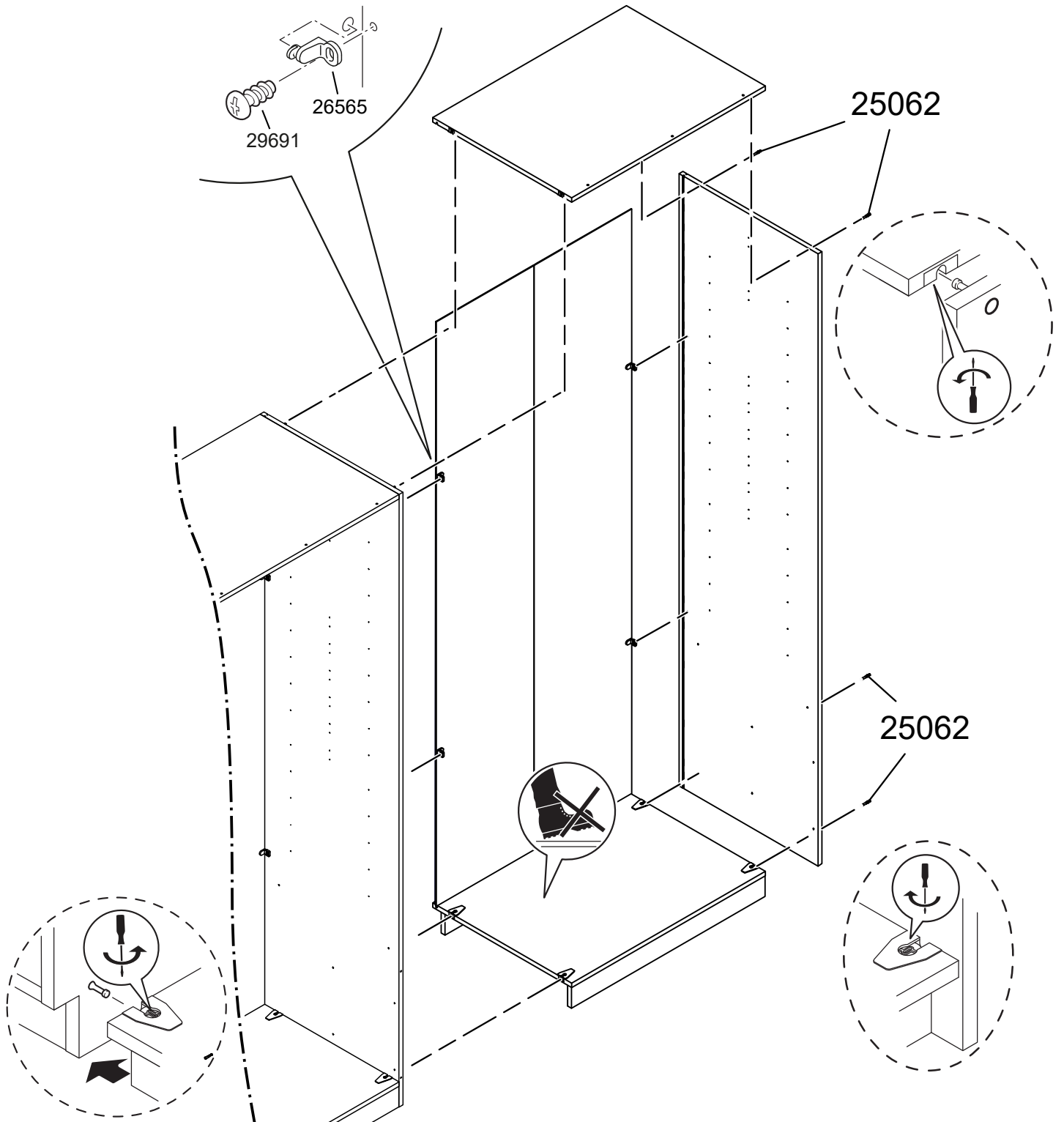

2.4

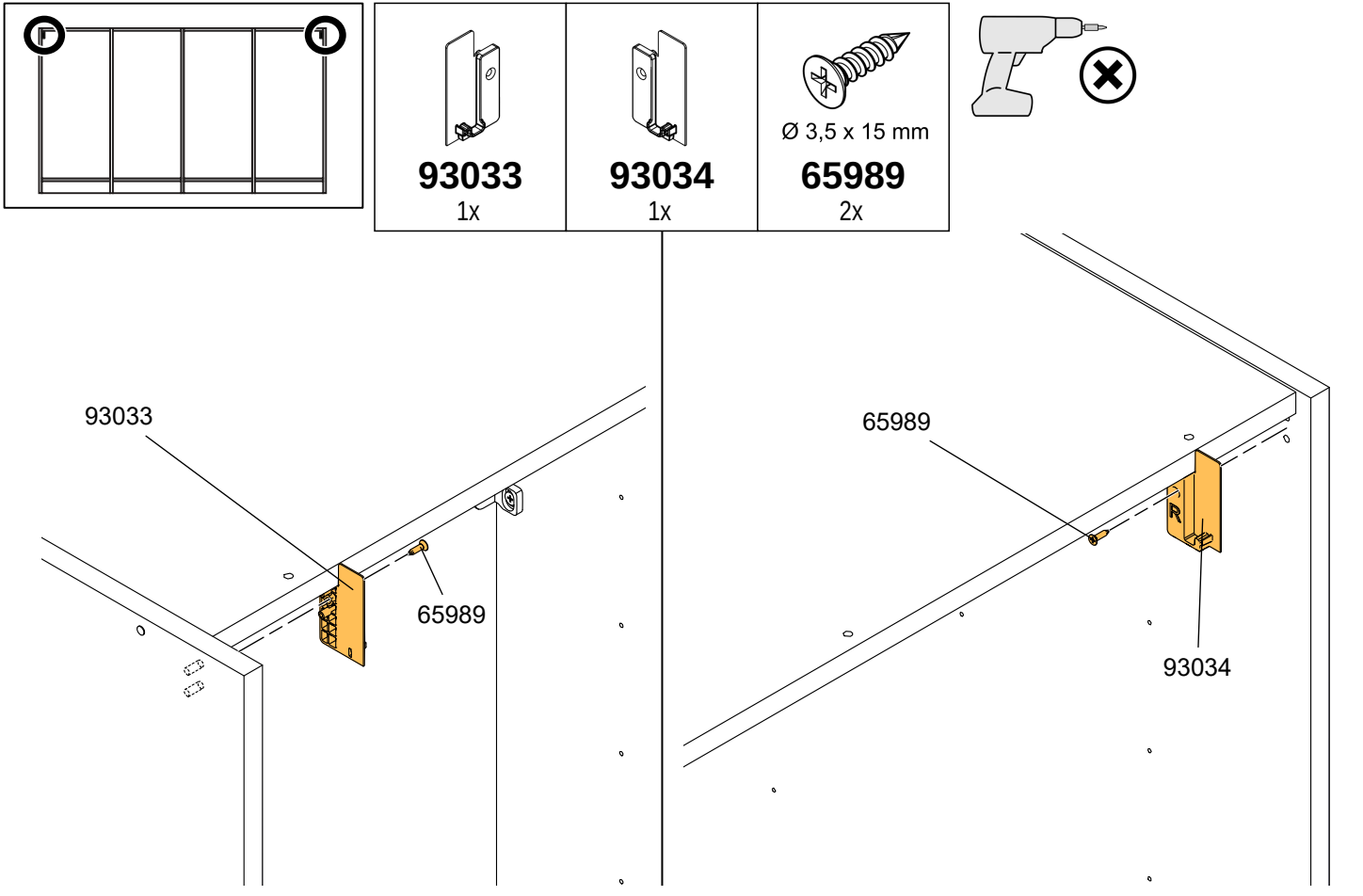

3.1

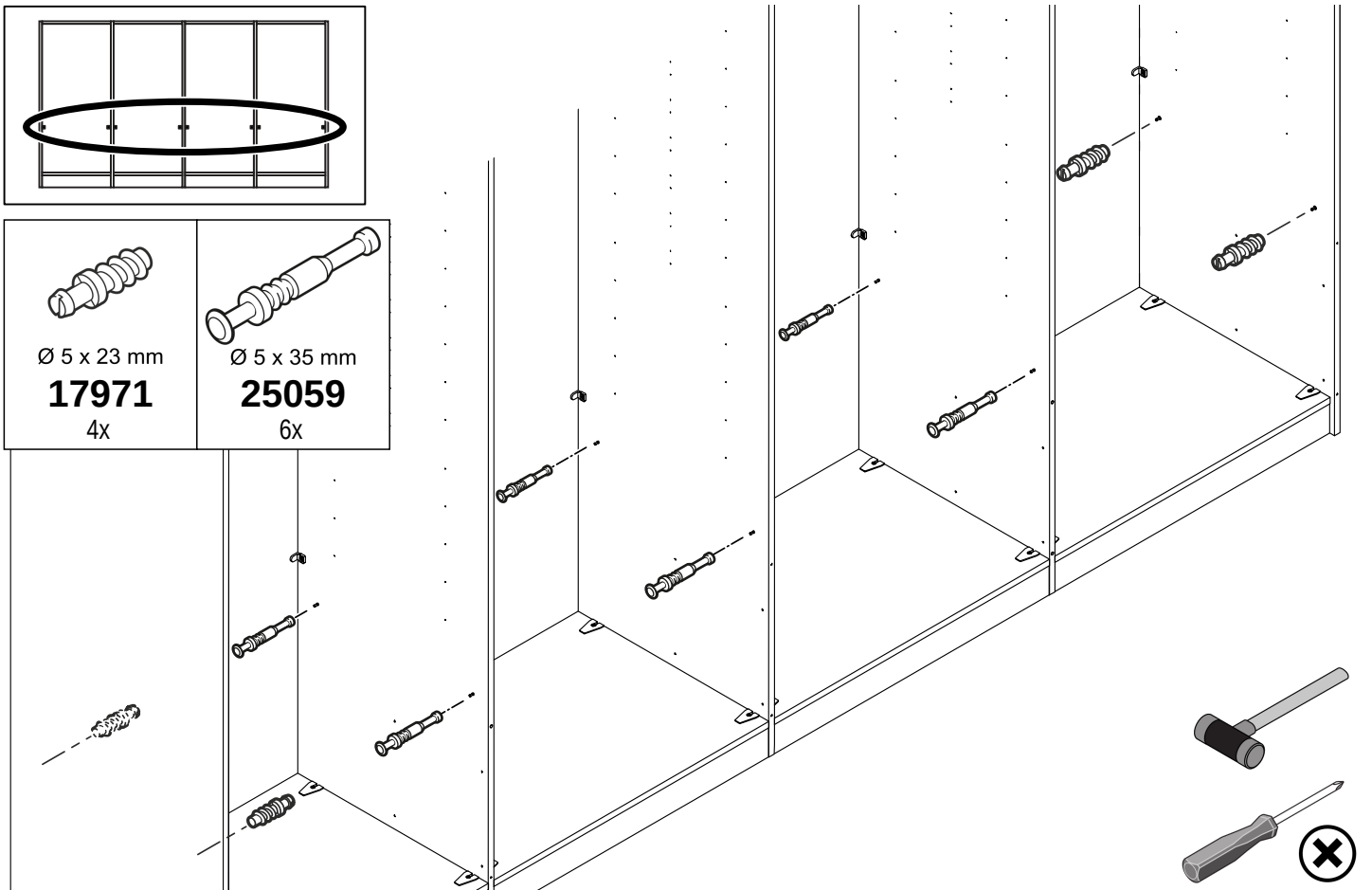

3.2

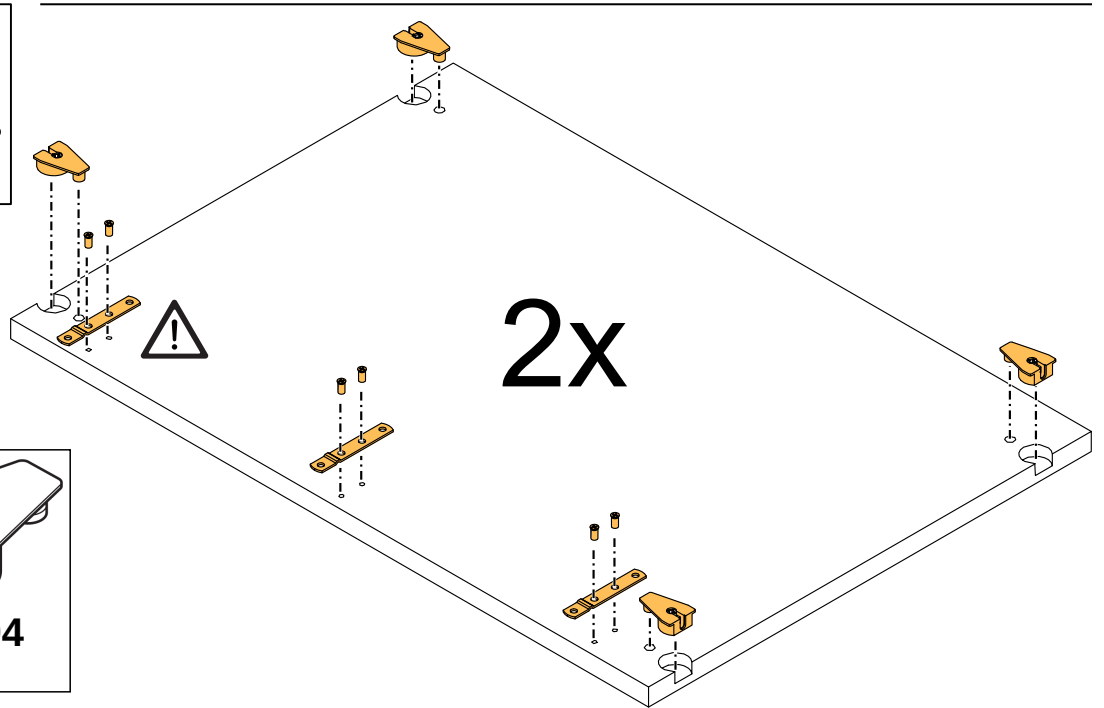
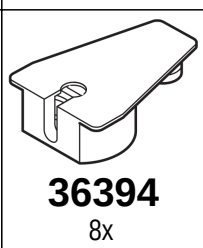
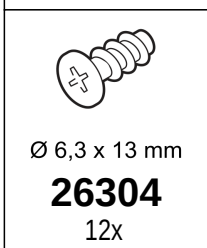
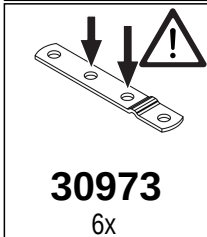
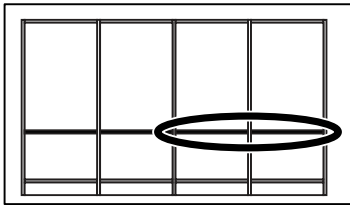
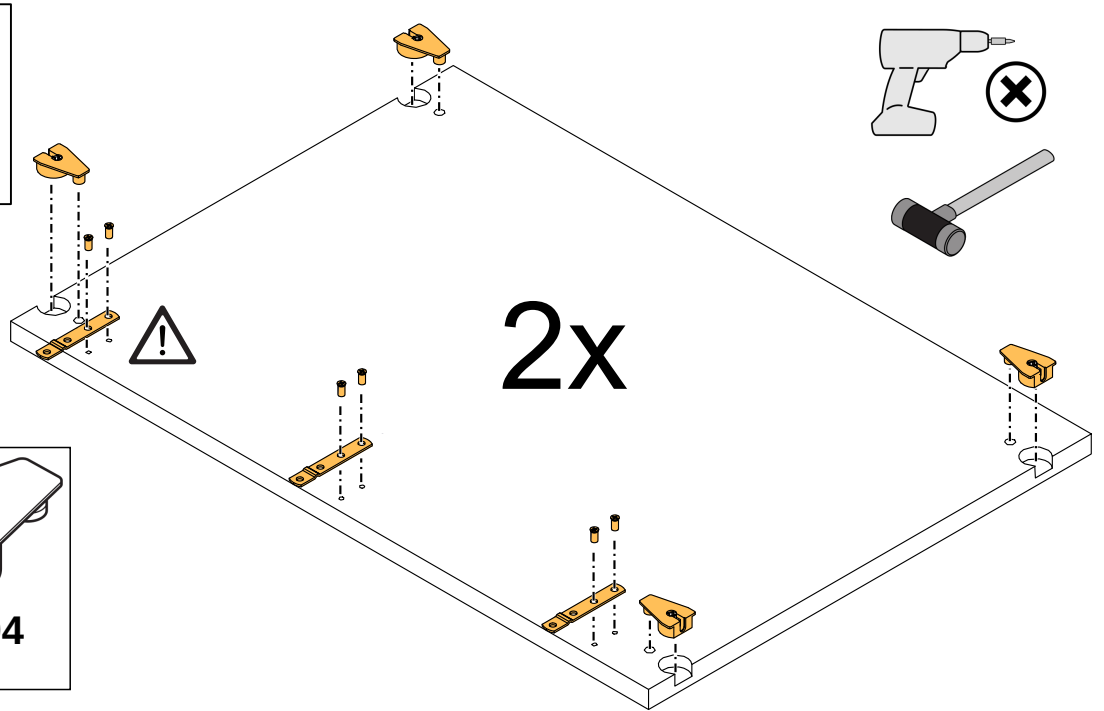
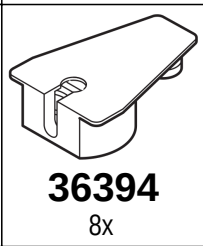
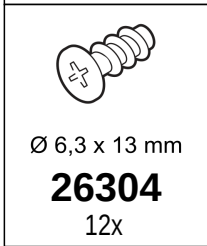
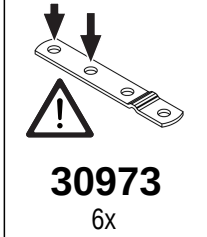
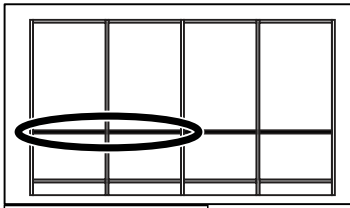

3.3

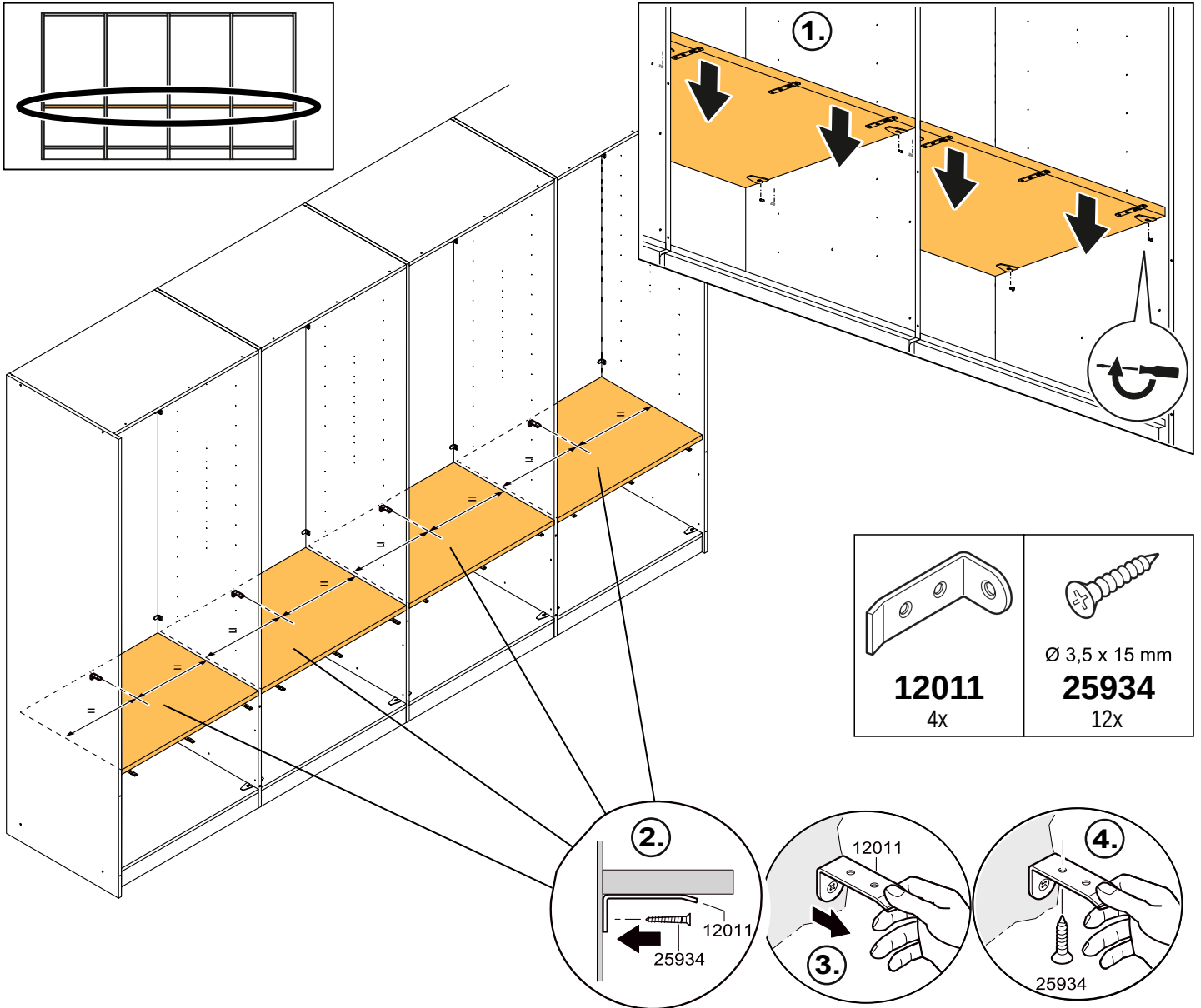
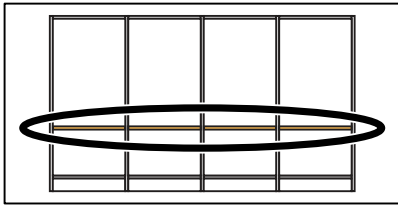

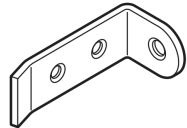
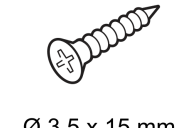
	
<p>12011 4x</p>	<p>Ø 3,5 x 15 mm 25934 12x</p>

3.4

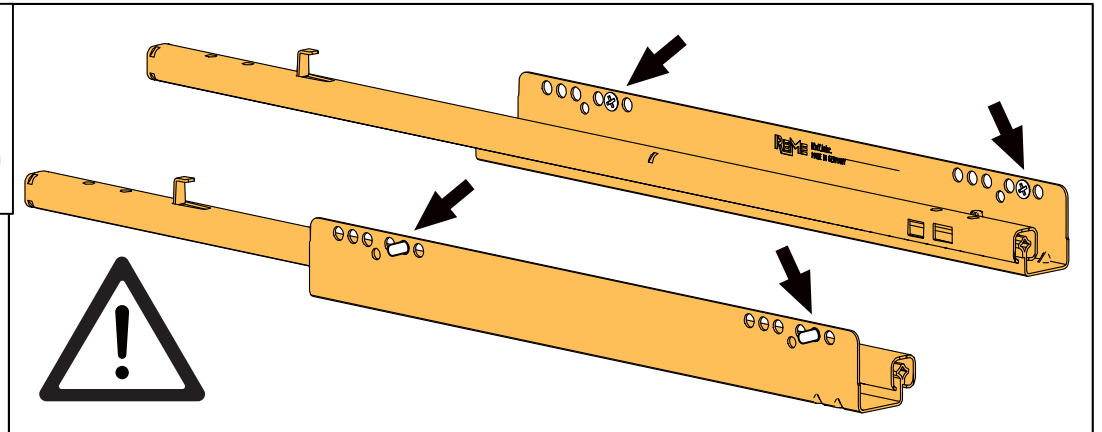
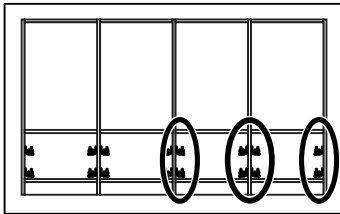
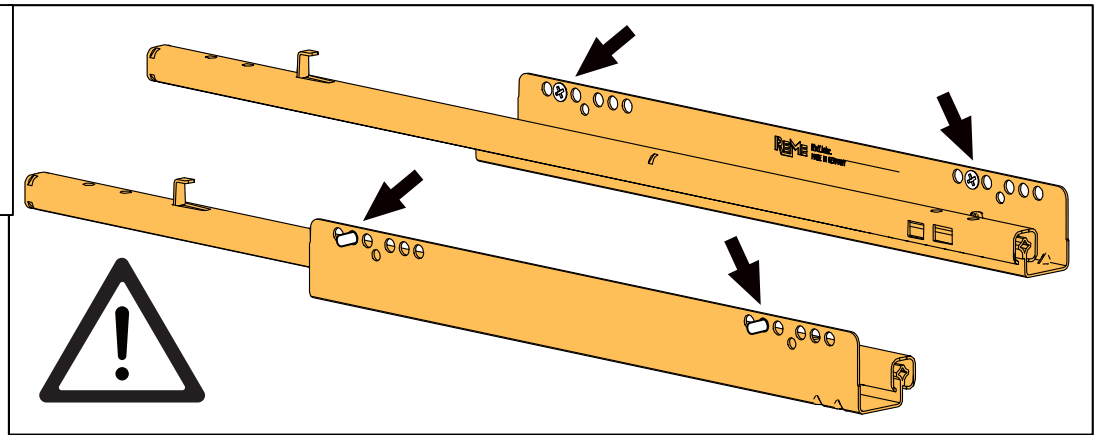
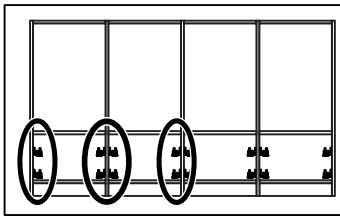
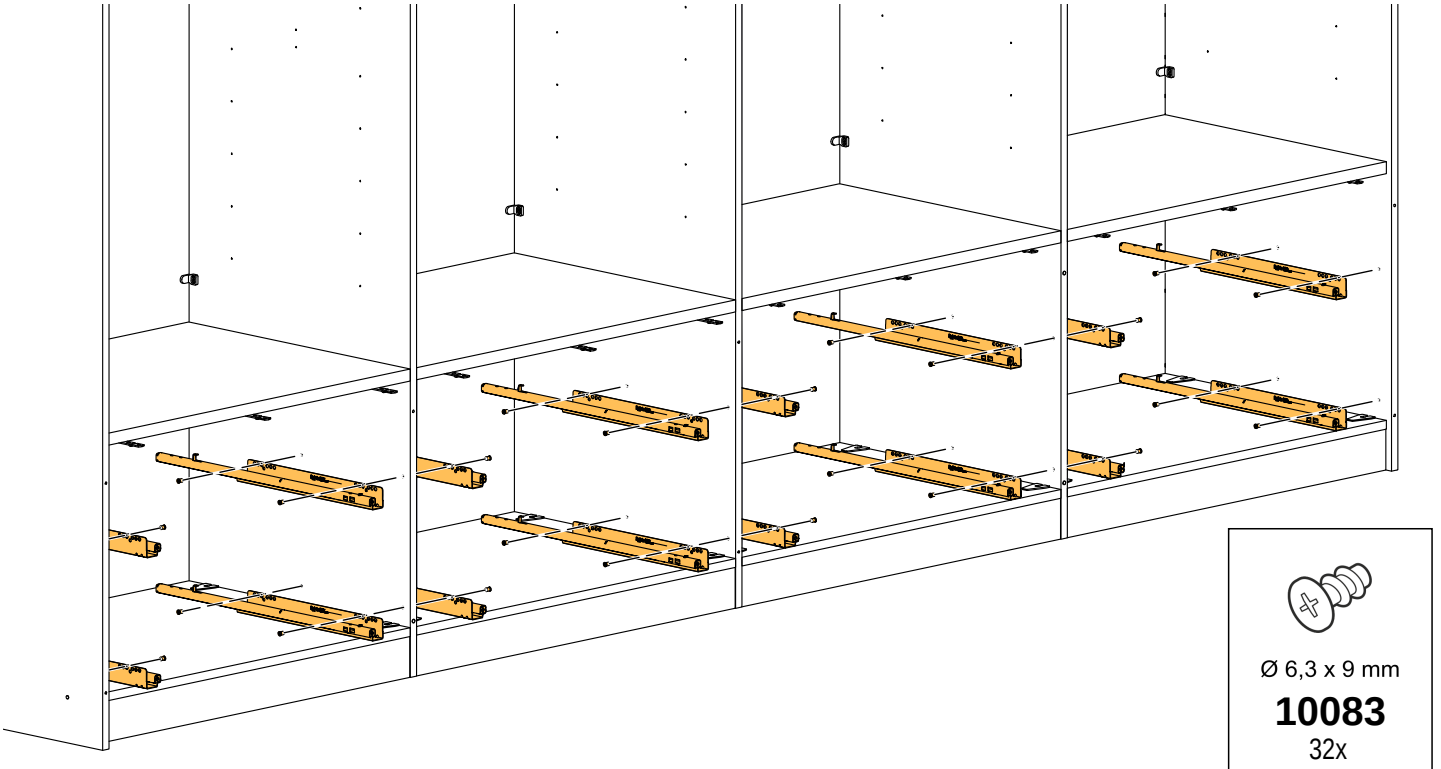

3.5

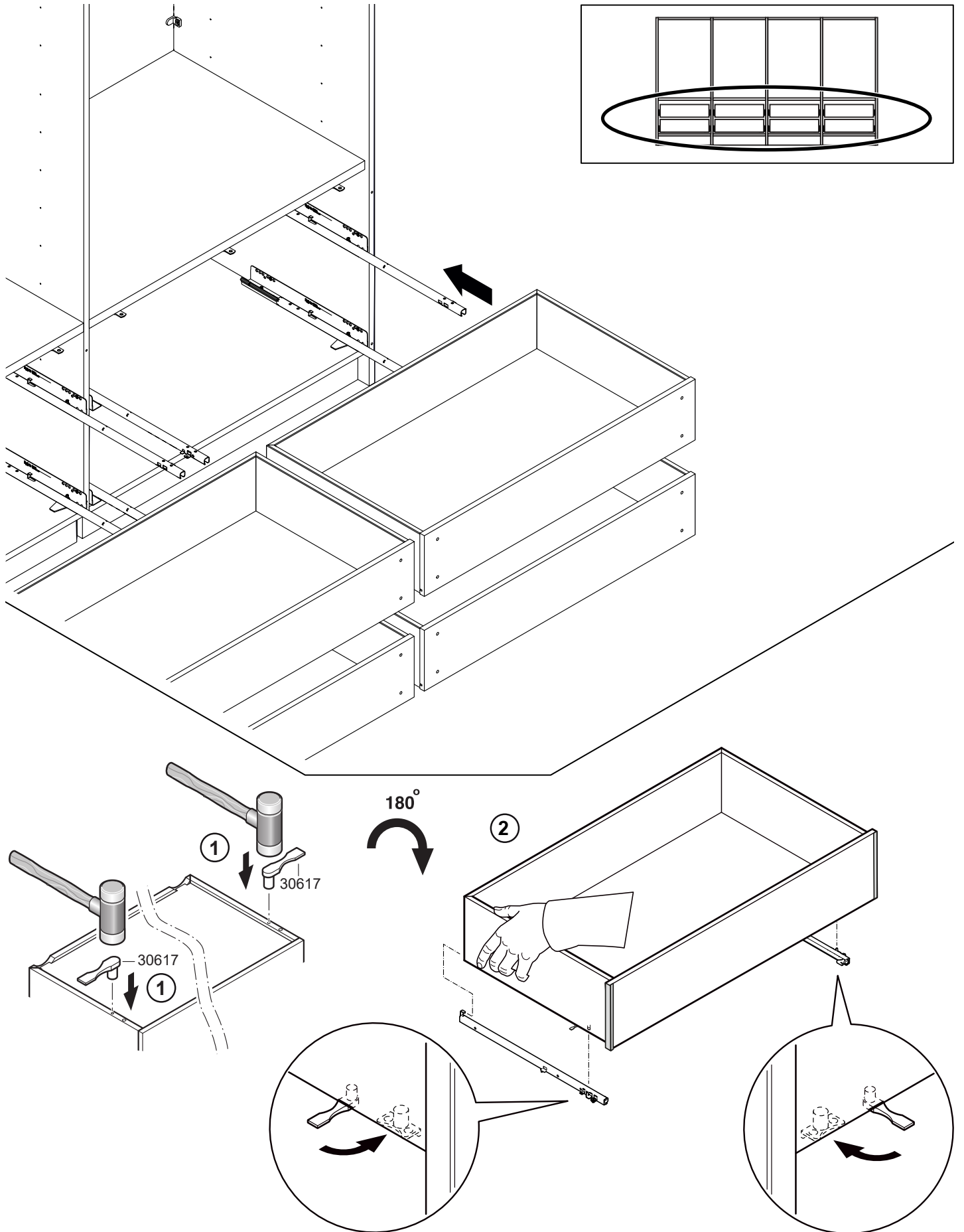

4.1

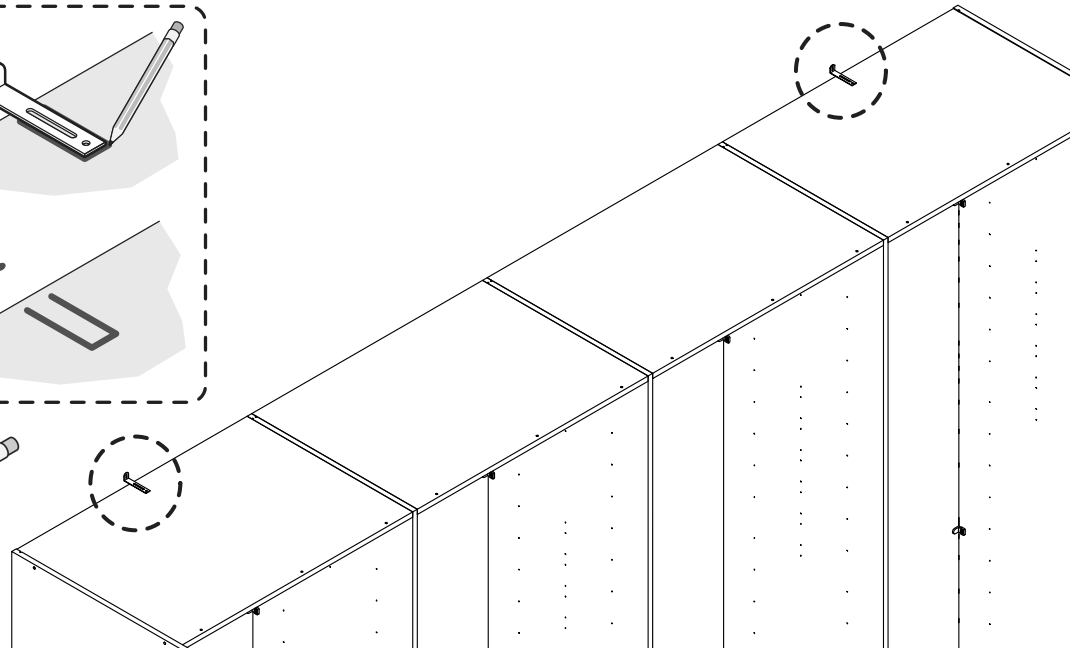
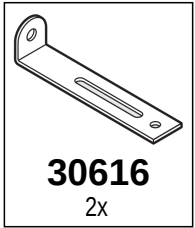
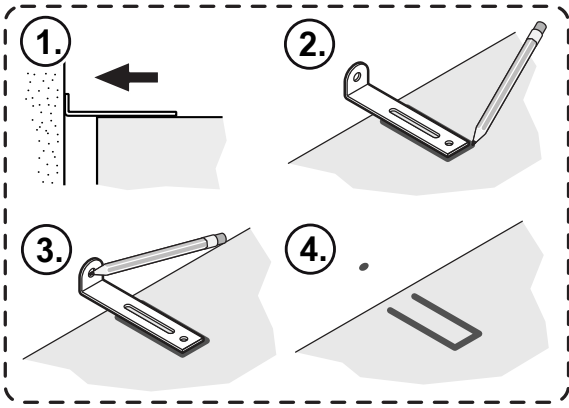

4.2

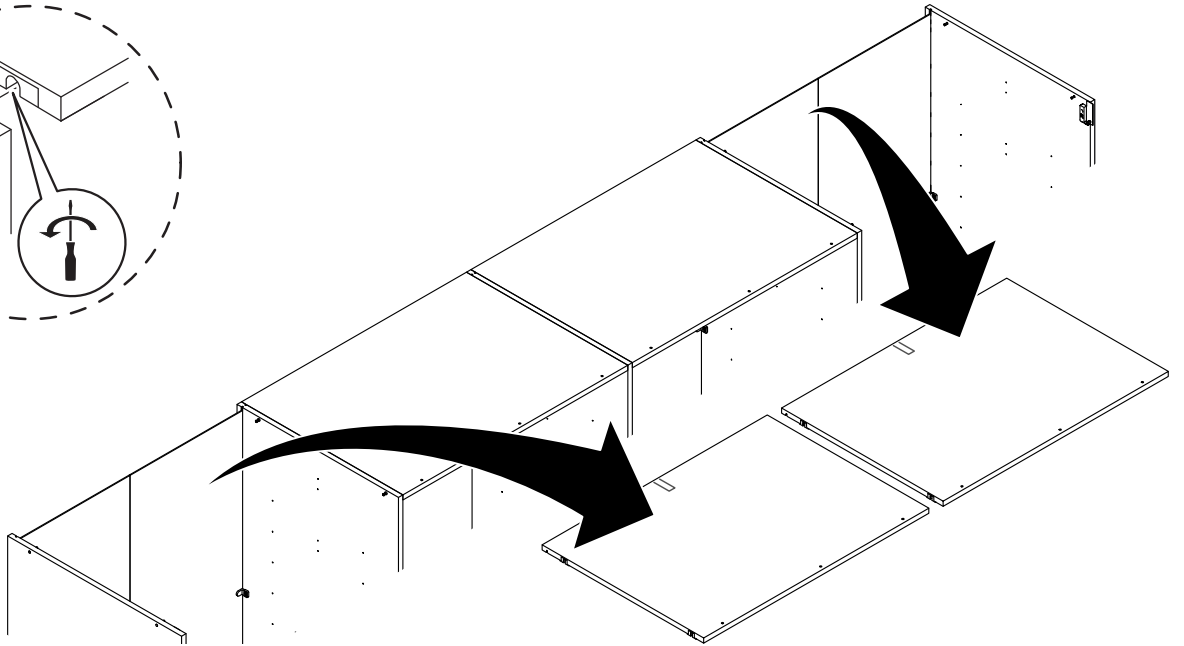
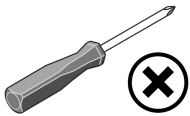
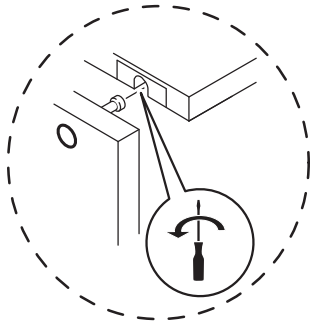

4.3

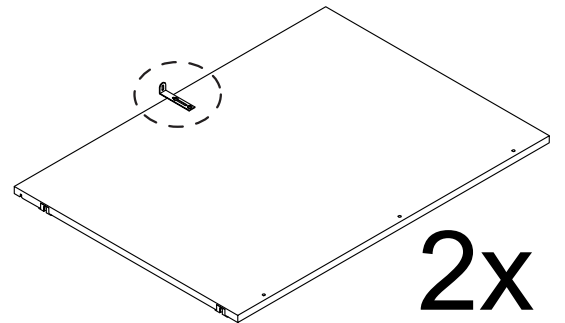
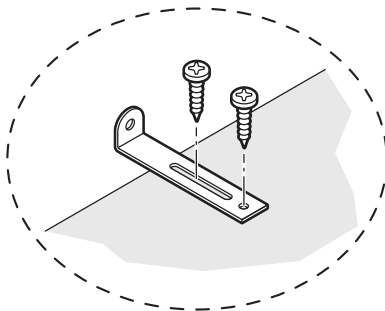
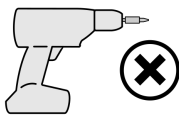

4.4

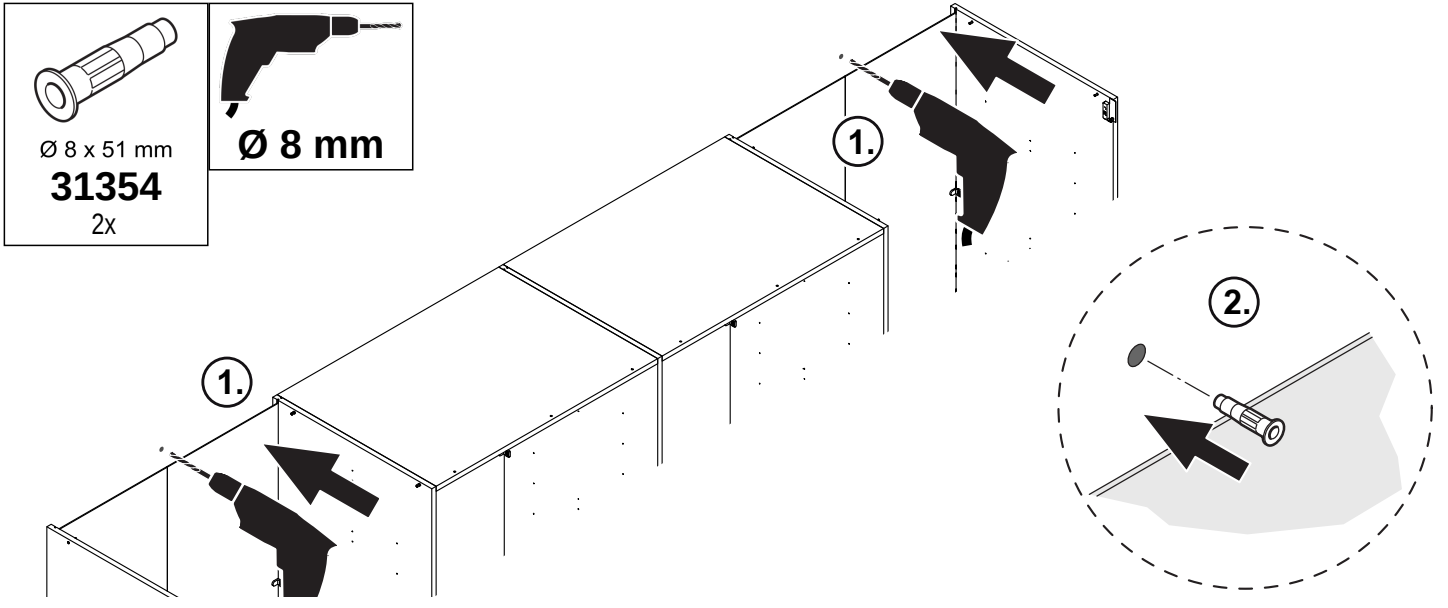



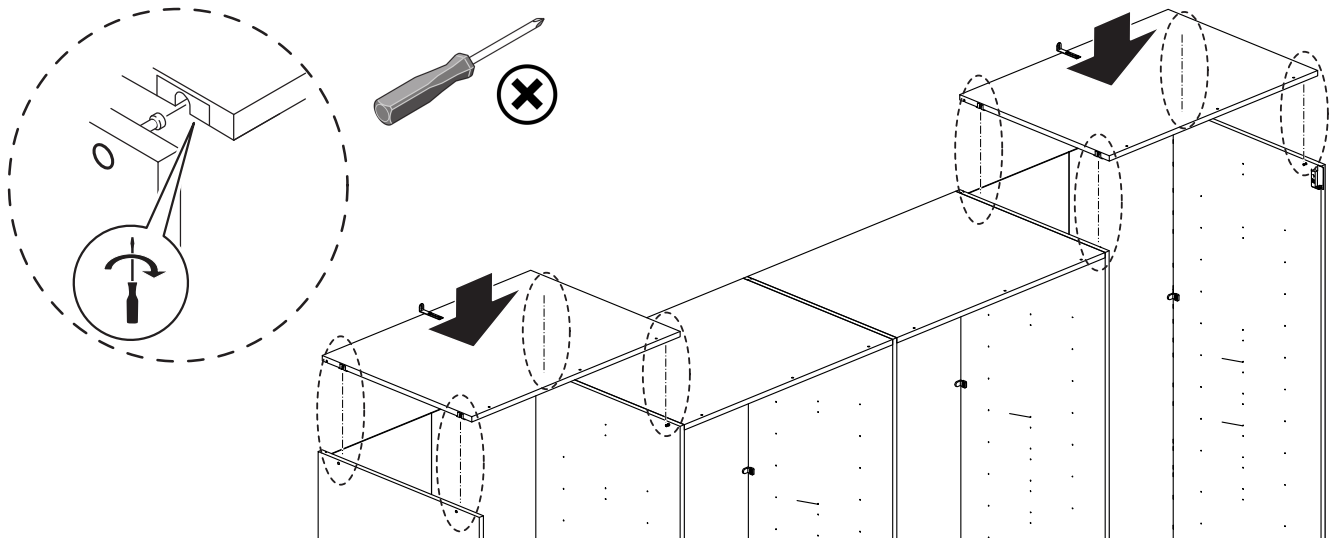

4.5

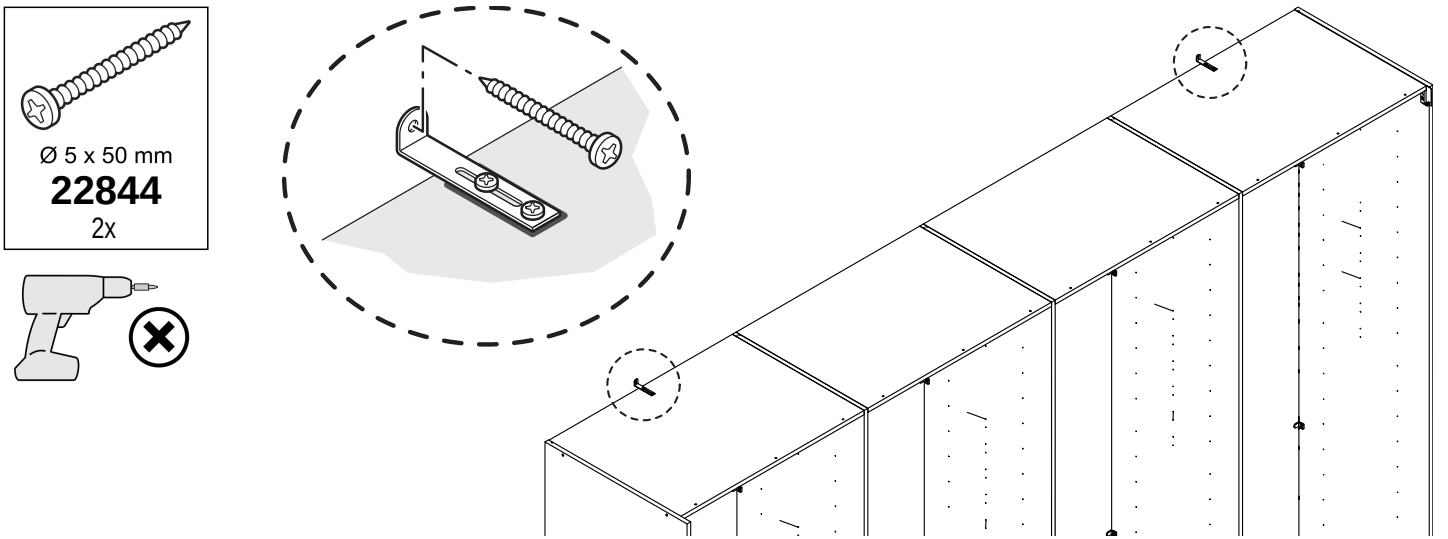

4.6

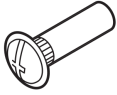

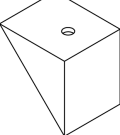
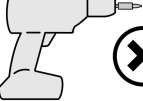
5.

 Ø 5 x 15 mm 22681	 Ø M4 x 8 mm 28054
 14112 4x	 

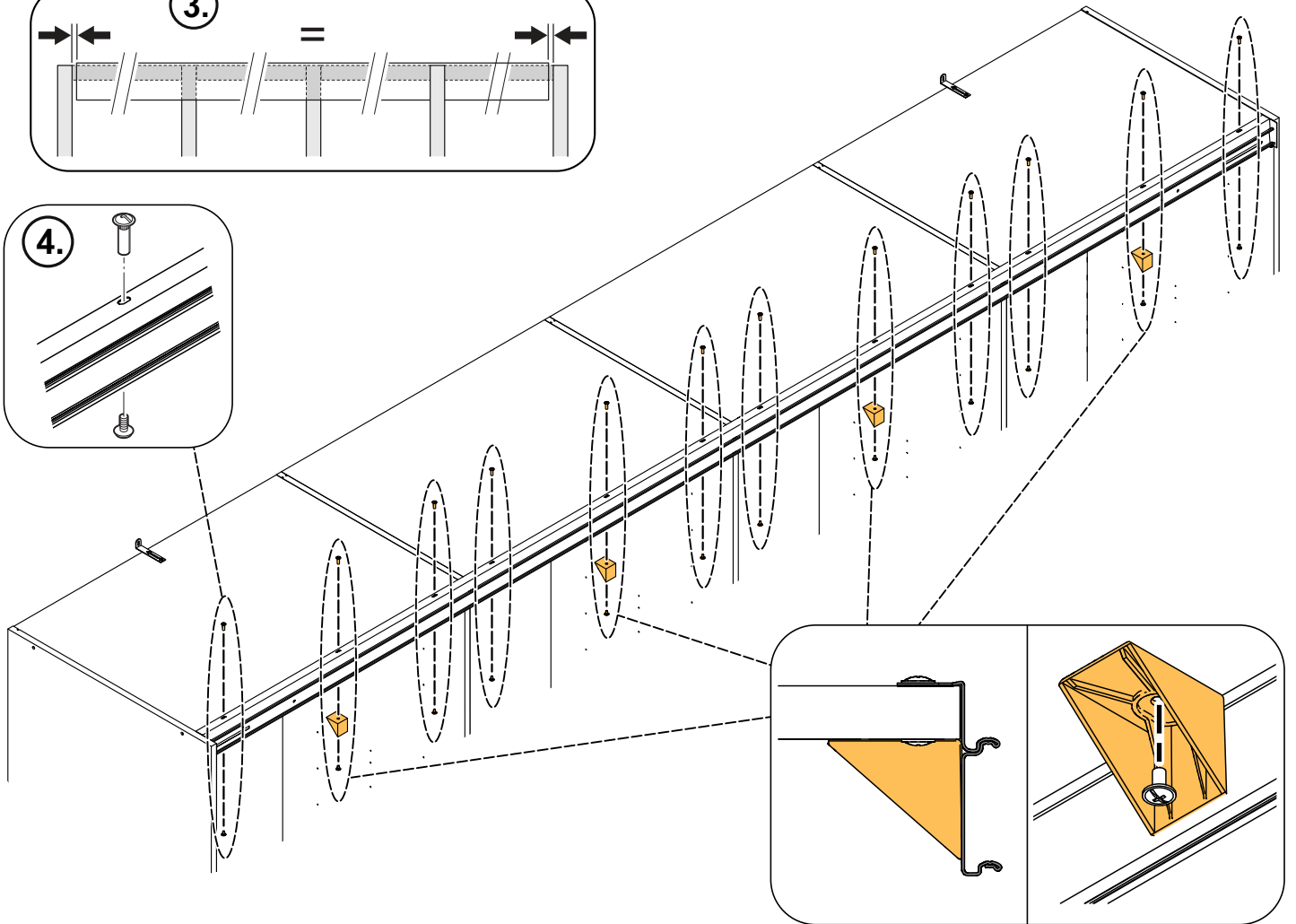
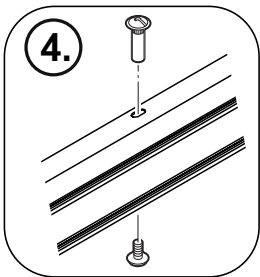
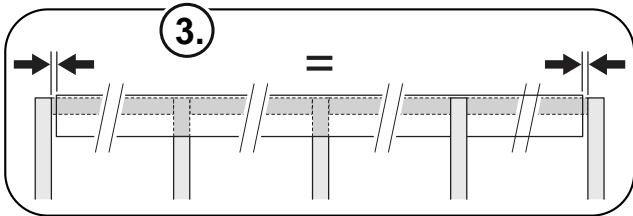
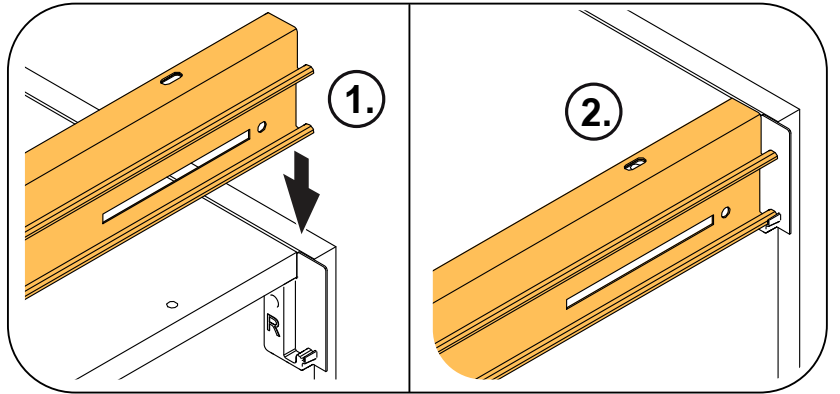

6.1

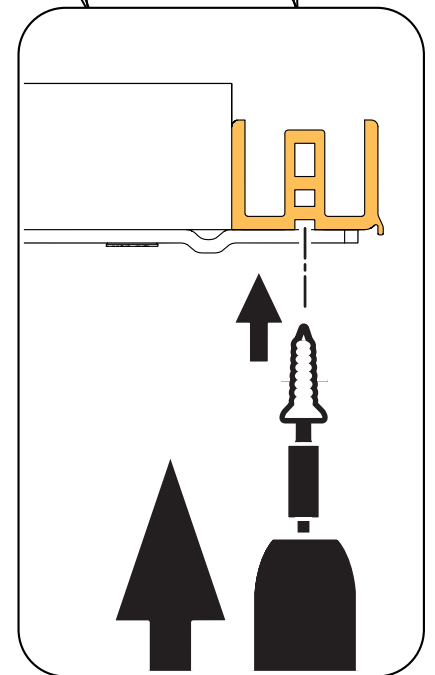
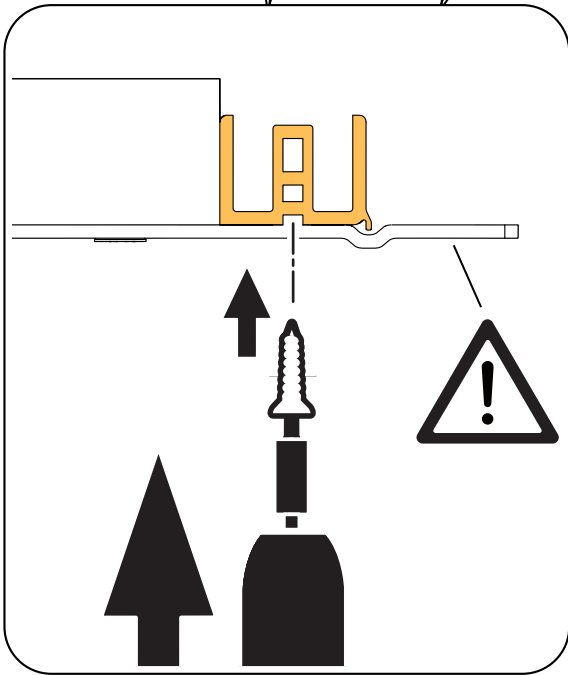
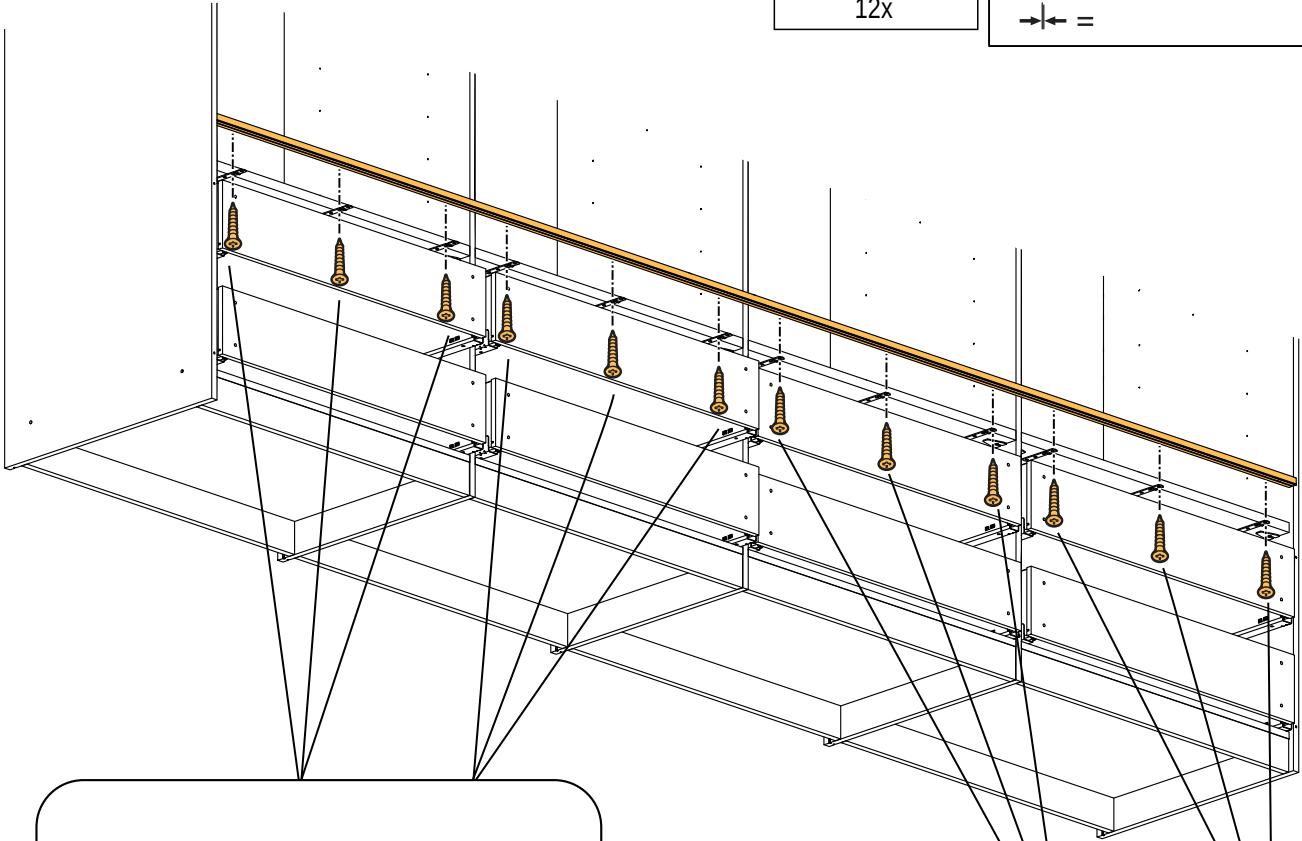
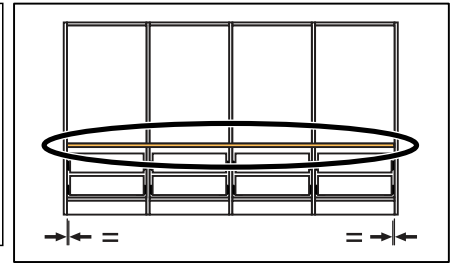
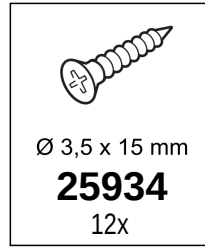
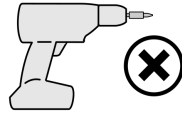

6.2

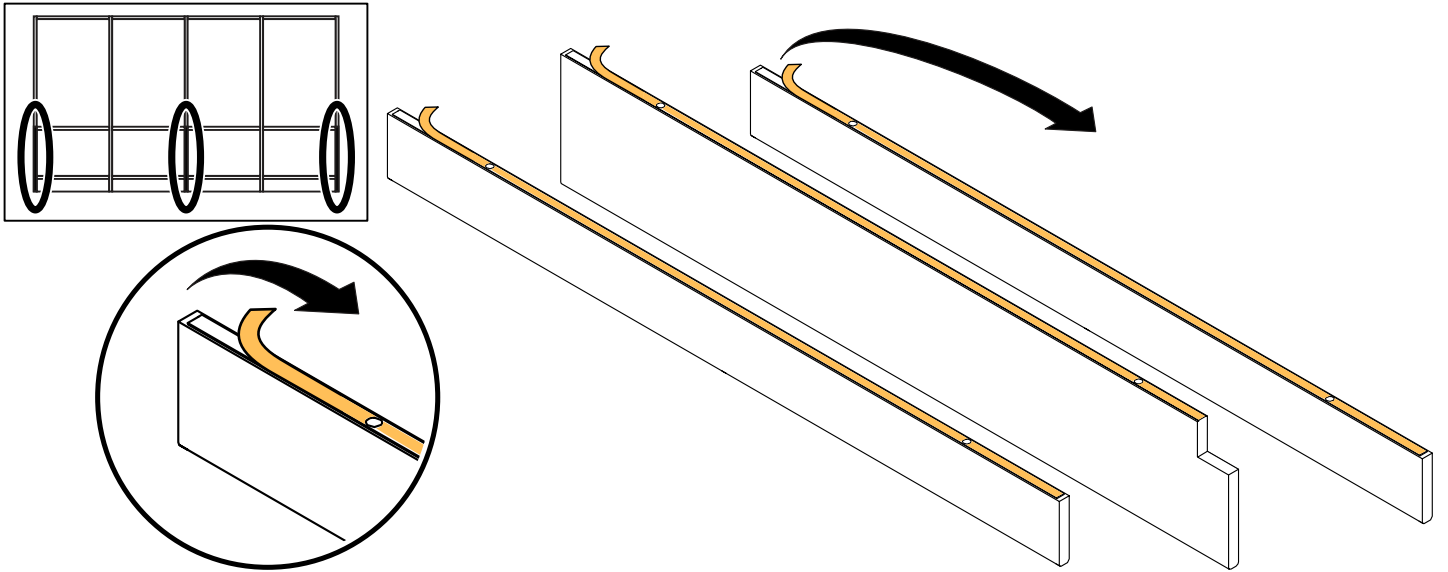

6.3

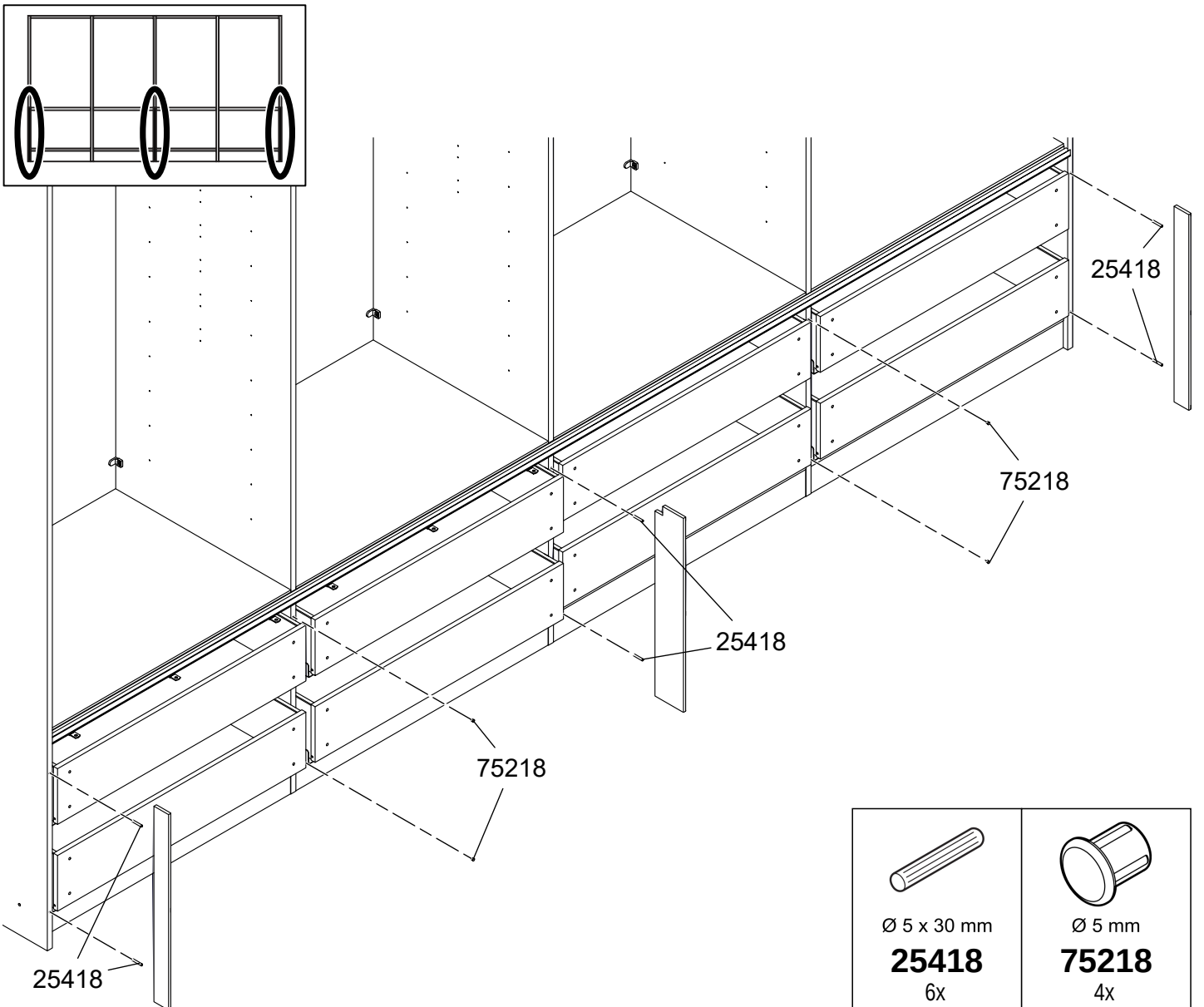

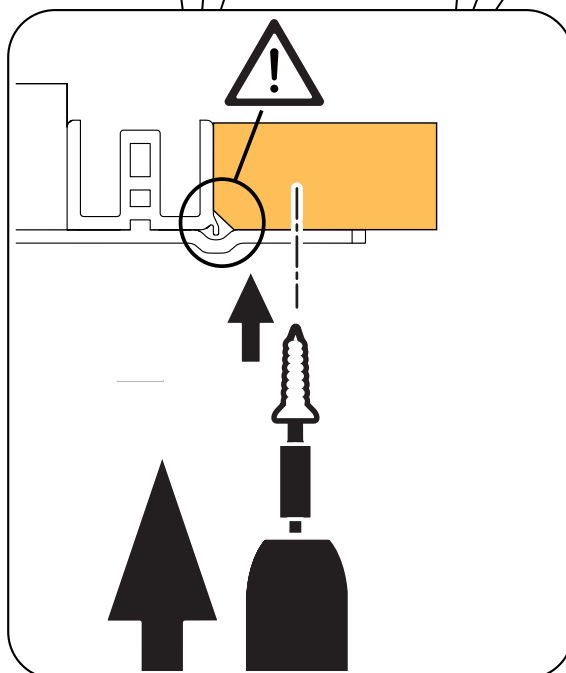
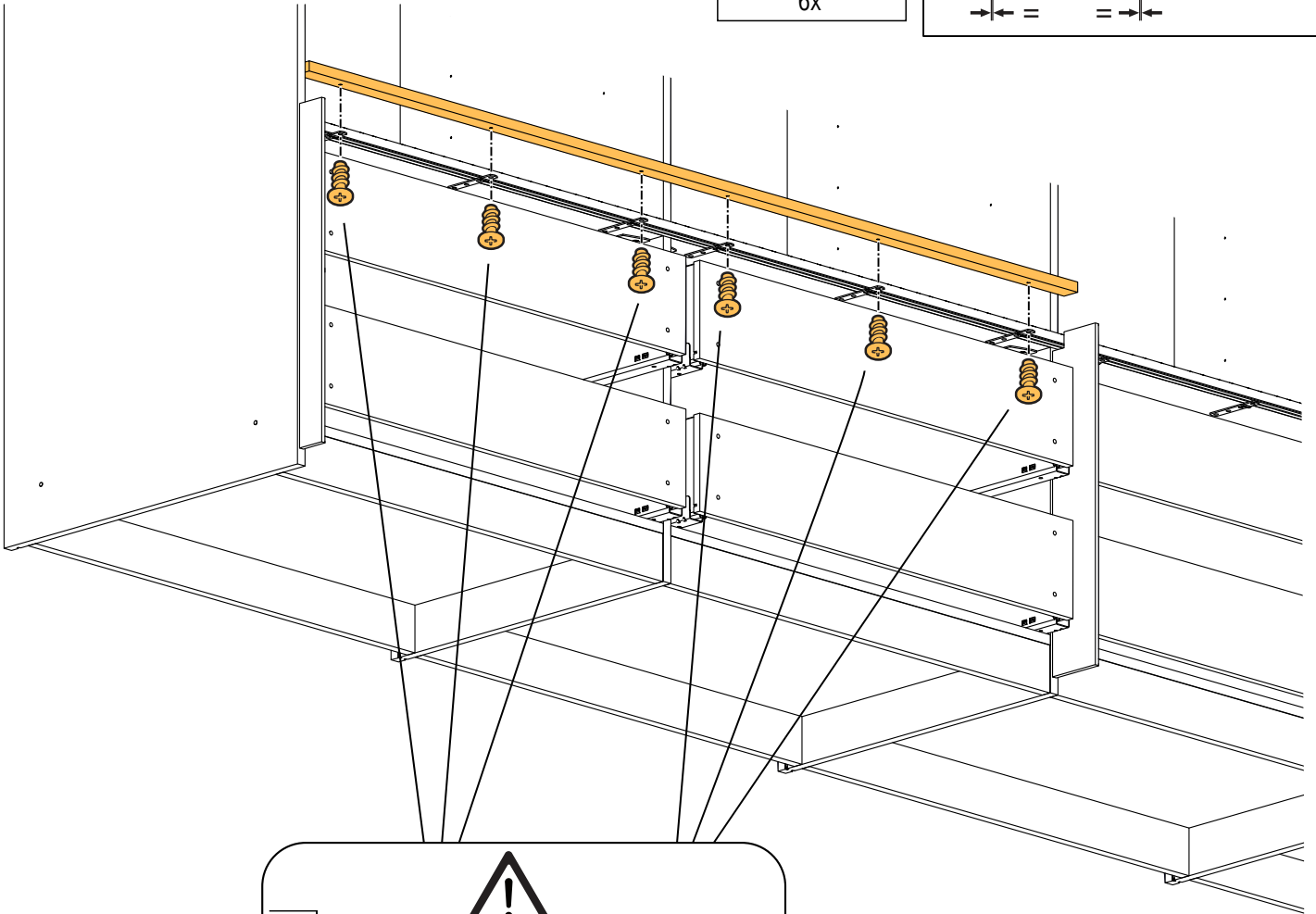
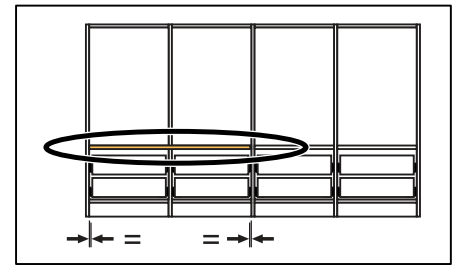
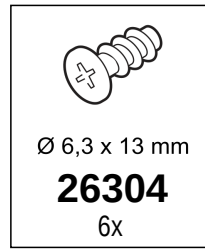
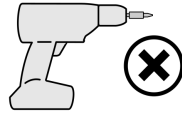

6.4

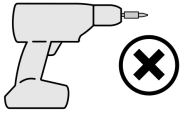

7.



 Ø 3 mm 46943 32x	 Ø 3 mm 09125 8x	 Ø 4,2 x 10 mm 09126 48x
--	---	---

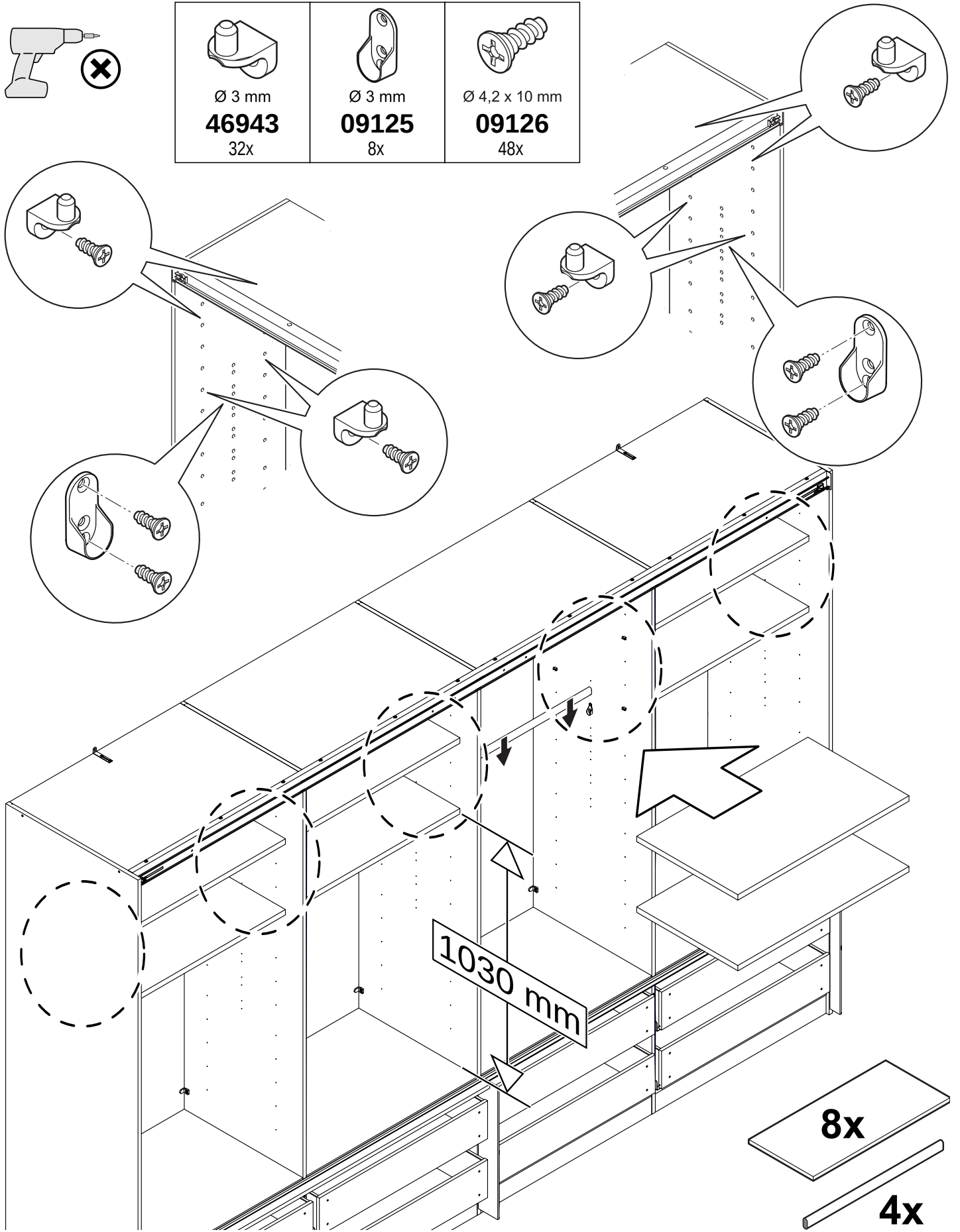

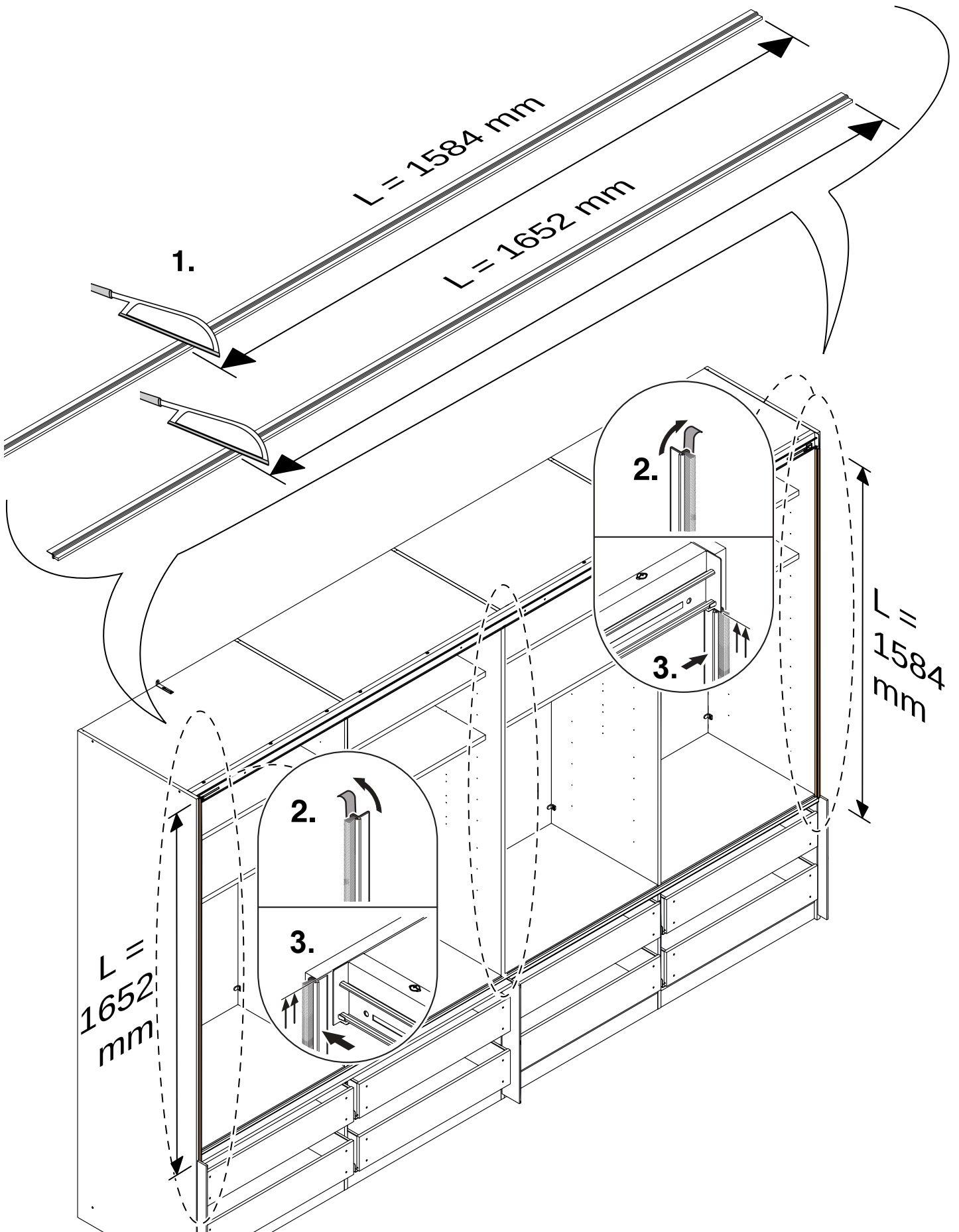

8.





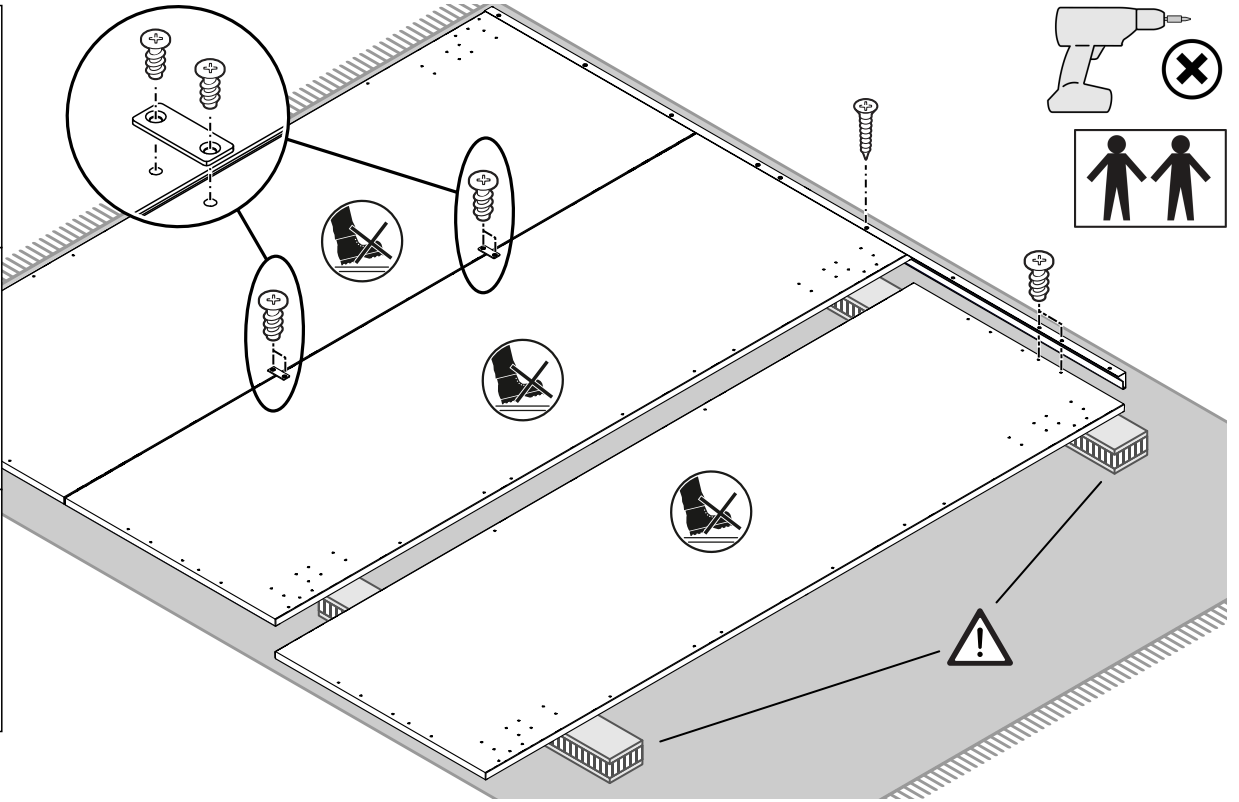

9.3

68228 2x

Ø 6,3 x 13 mm 26304 6x

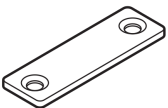
Ø 3,5 x 13 mm 25305 1x

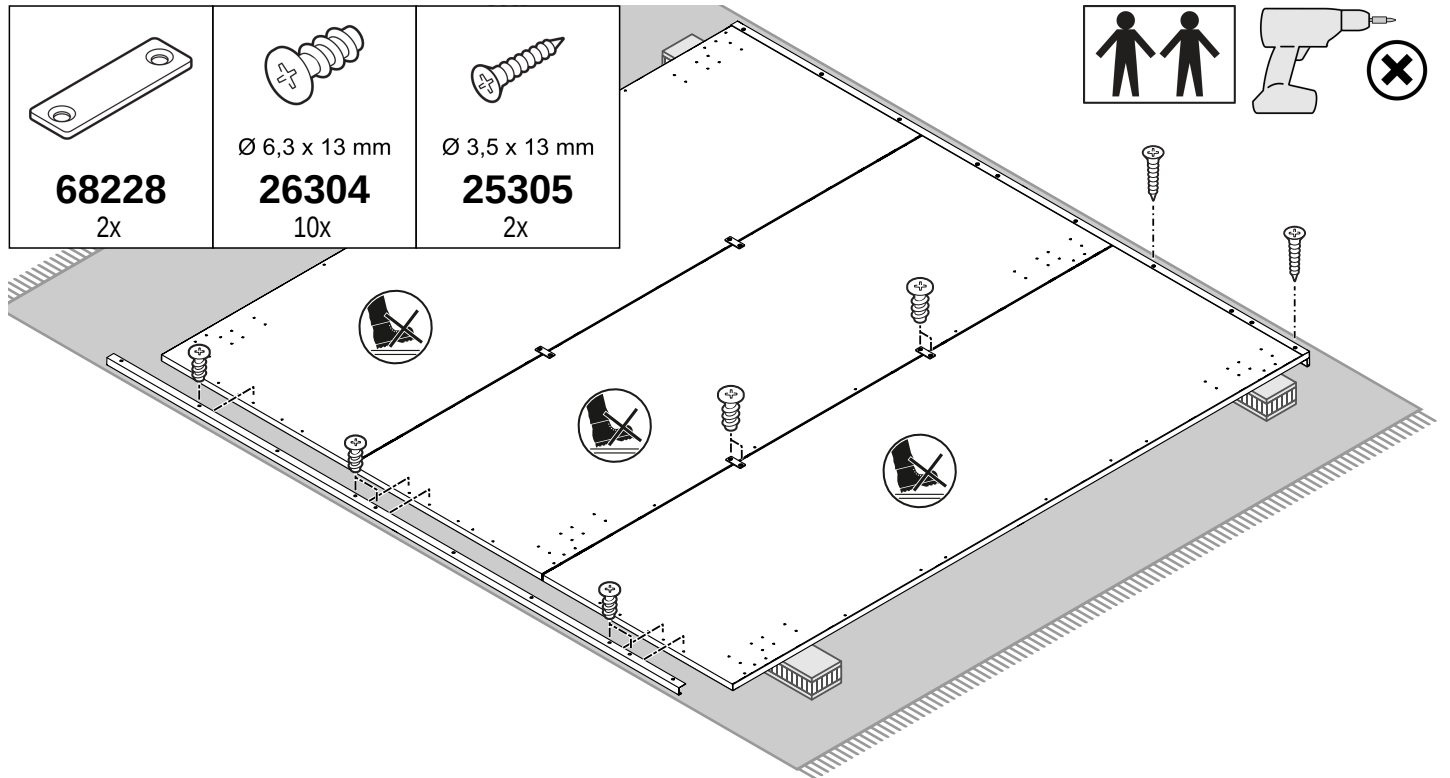

9.4

		
68228 2x	Ø 6,3 x 13 mm 26304 10x	Ø 3,5 x 13 mm 25305 2x





9.5

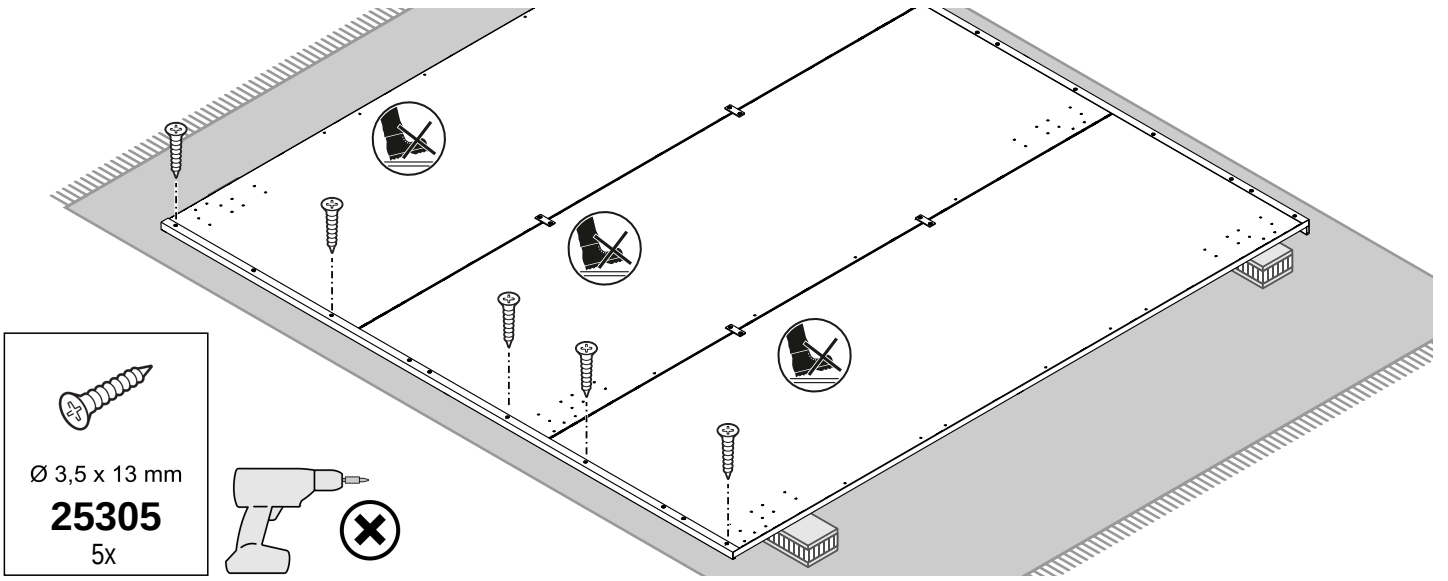

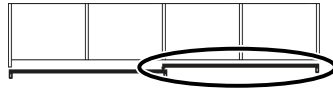

9.6

①

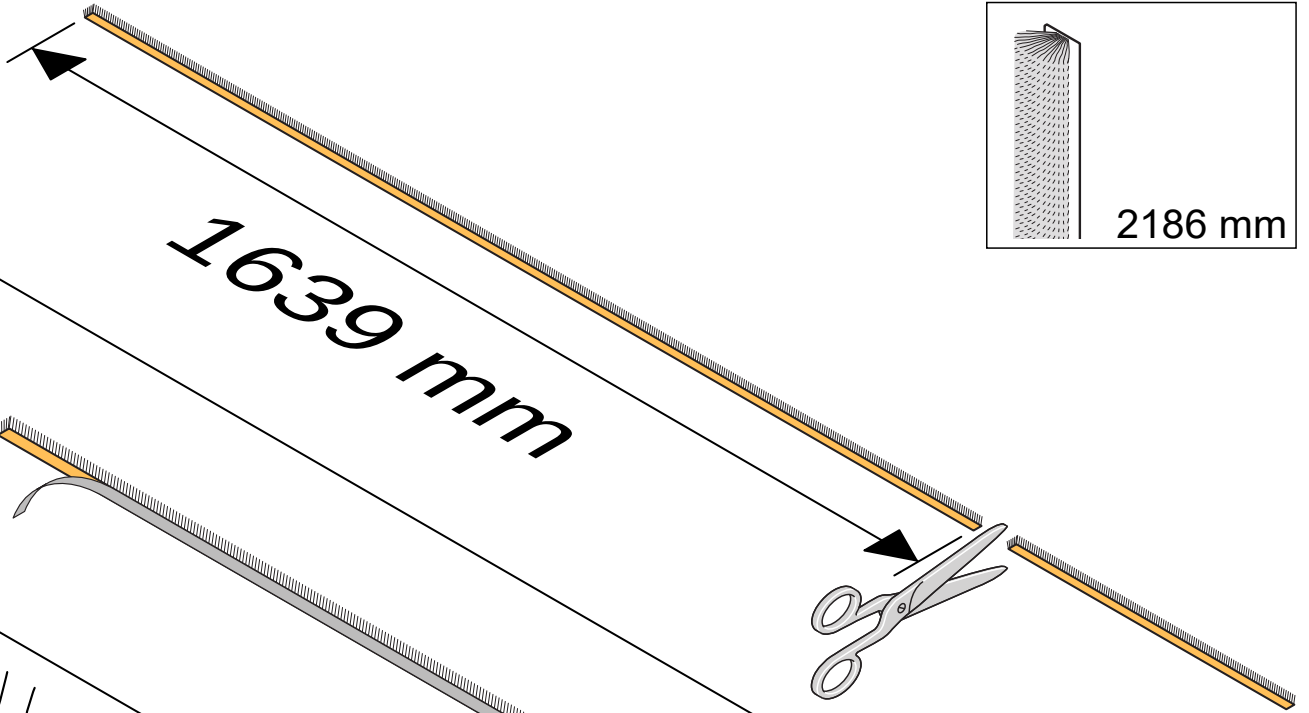

②

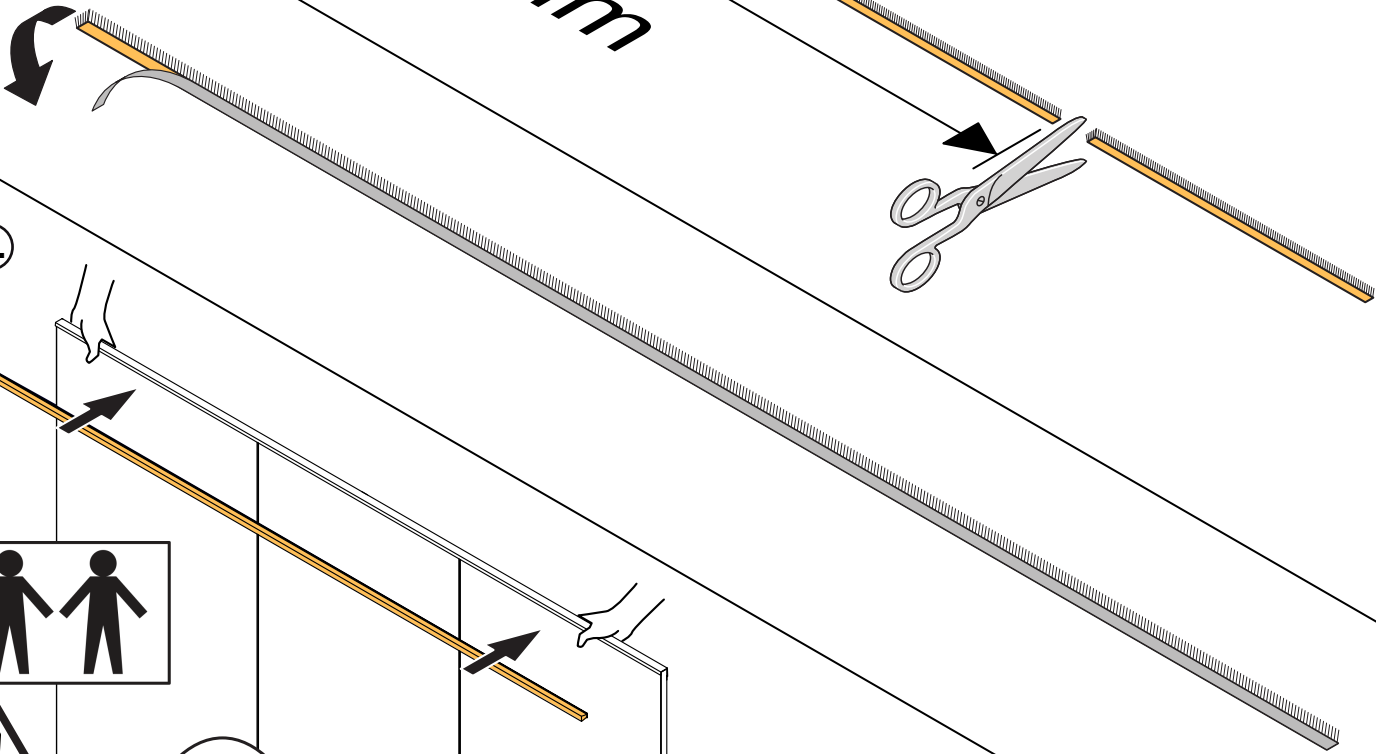

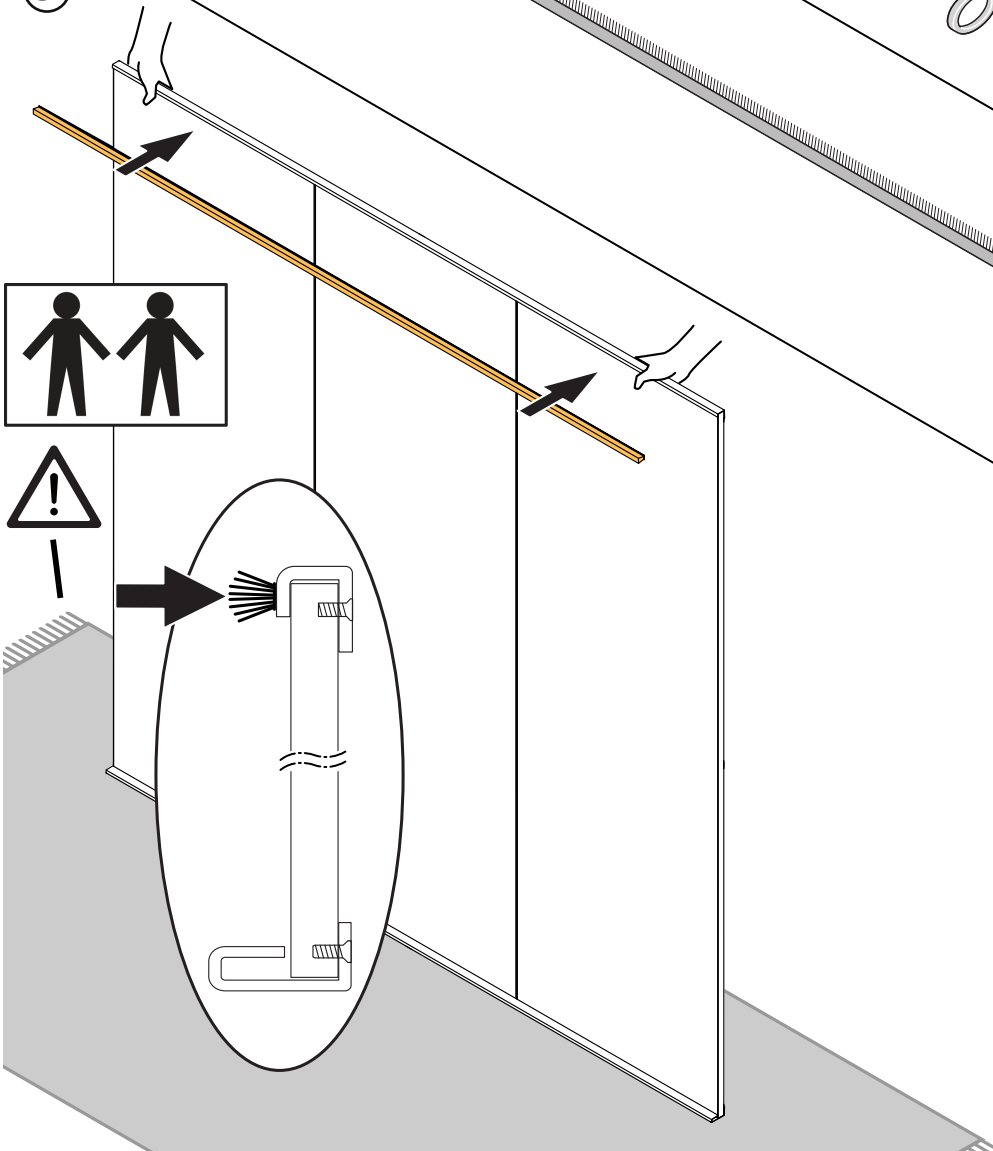

③

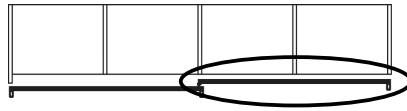
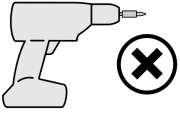

9.7

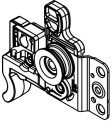
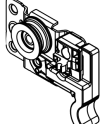

 <p>93498 1x</p>	 <p>93497 1x</p>	 <p>Ø 6,3 x 13 mm 26304 13x</p>
--	--	---

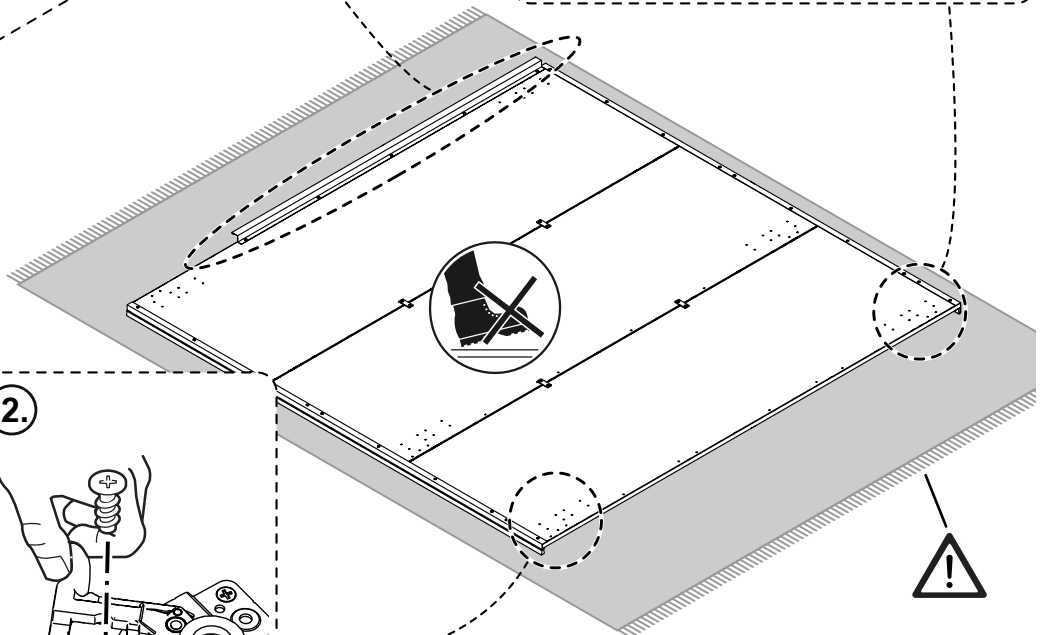
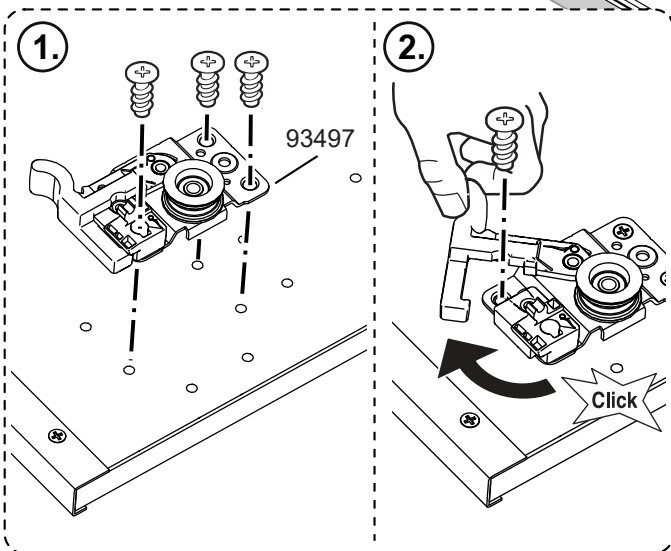
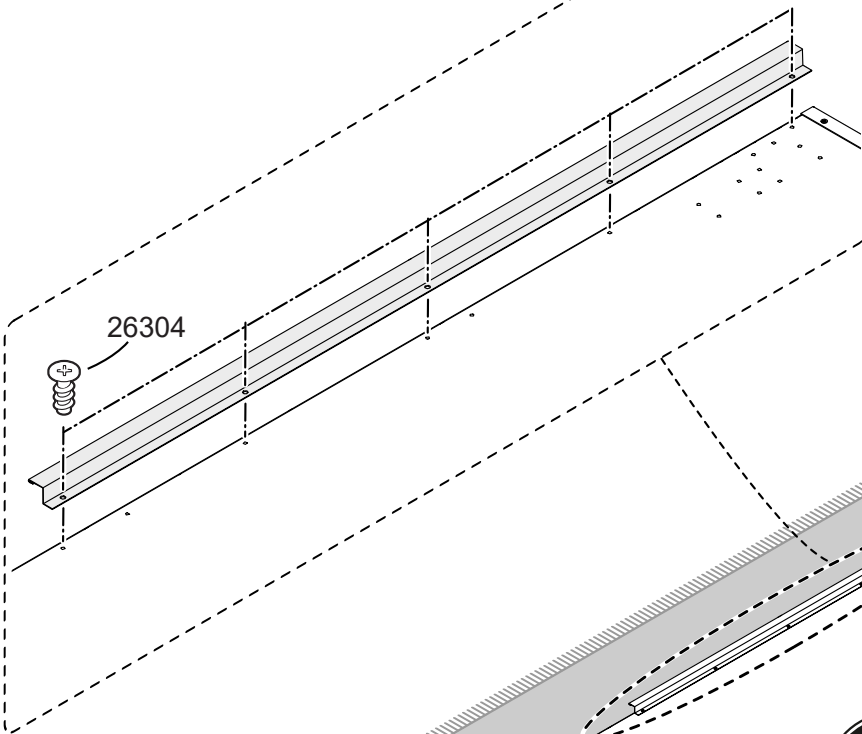
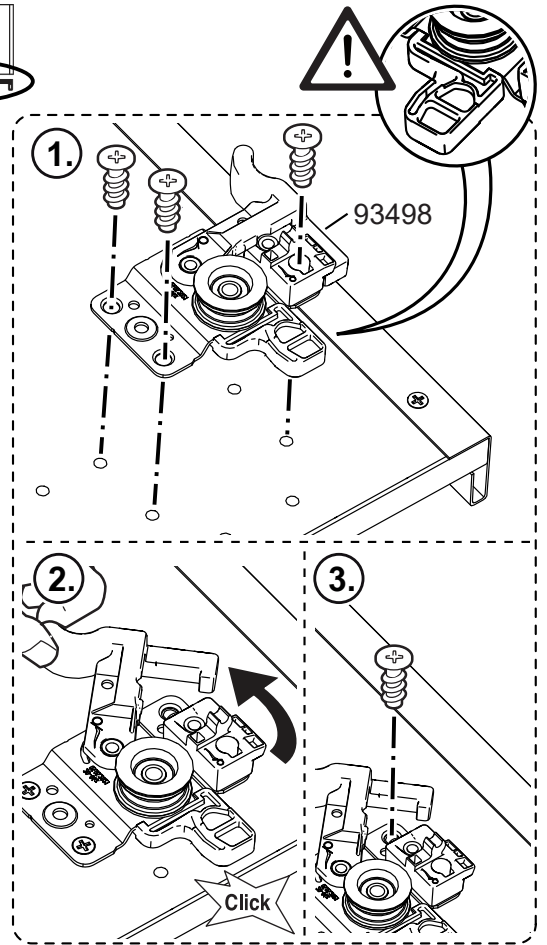

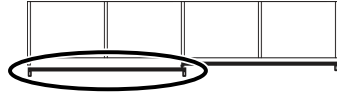

10.1

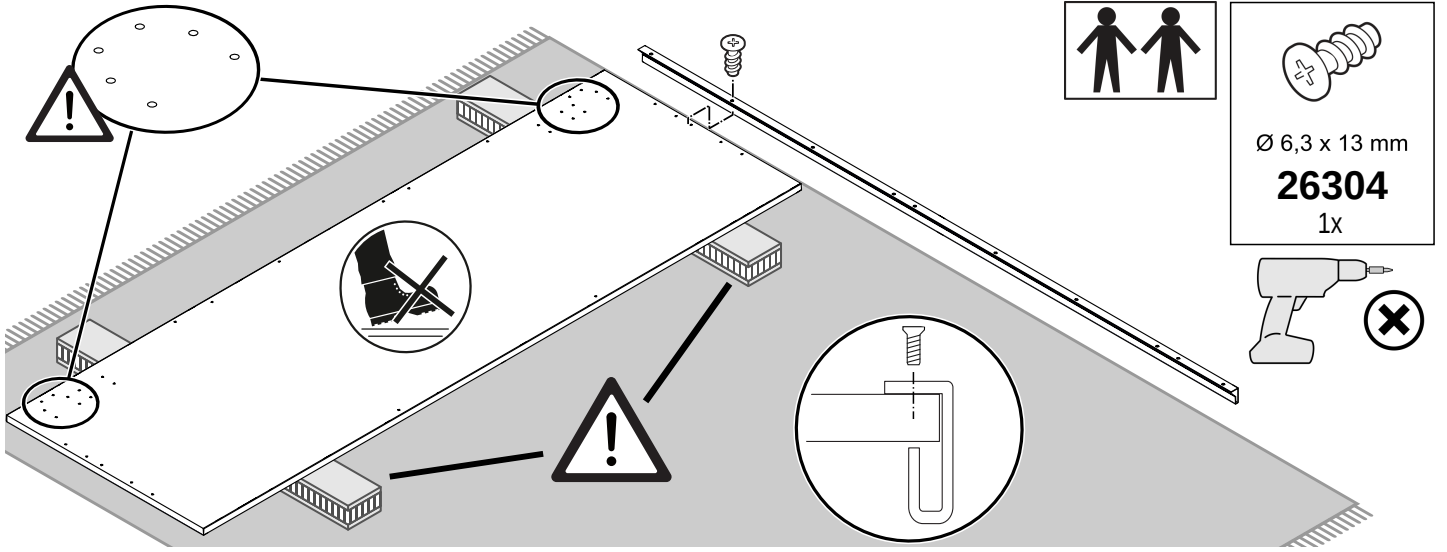

10.2

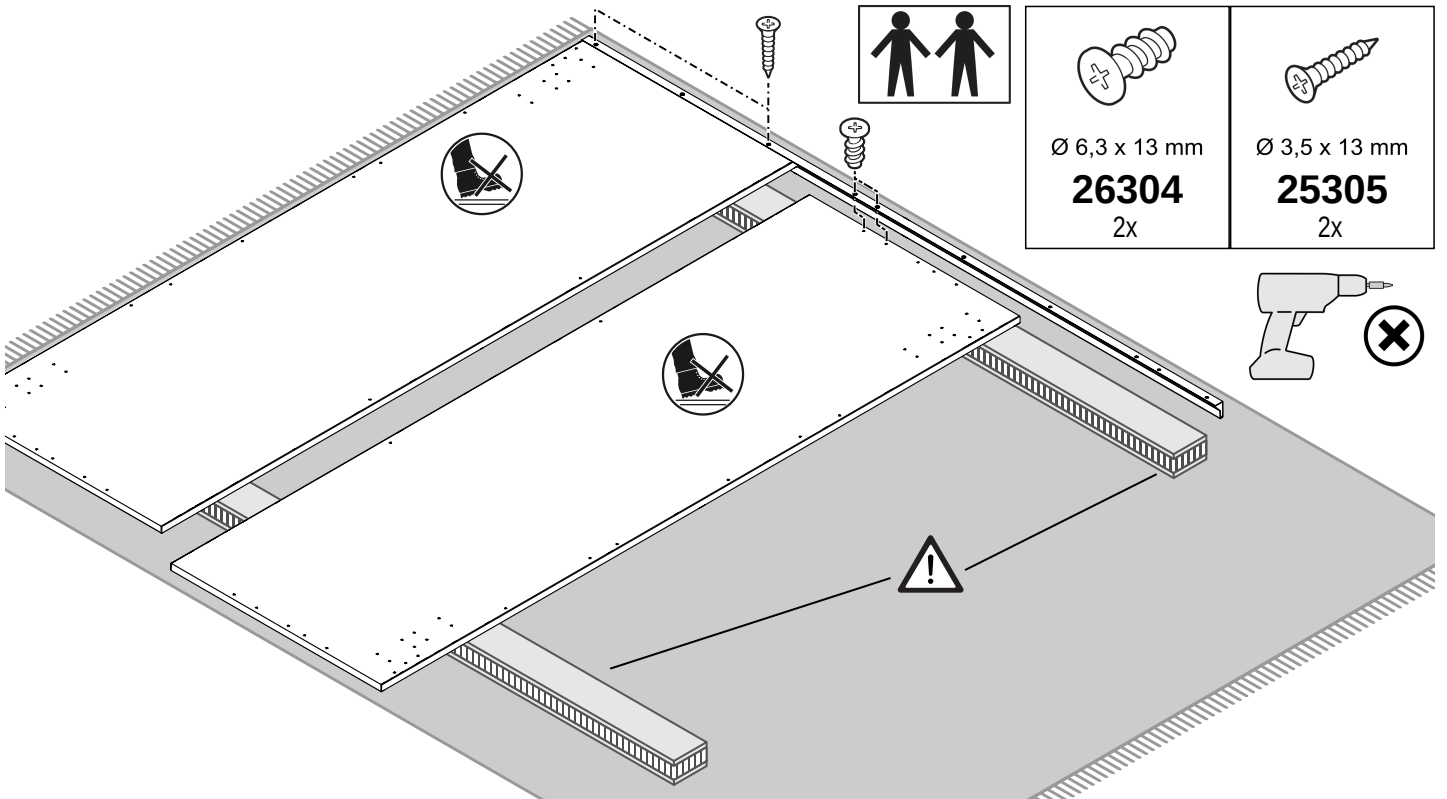

10.3

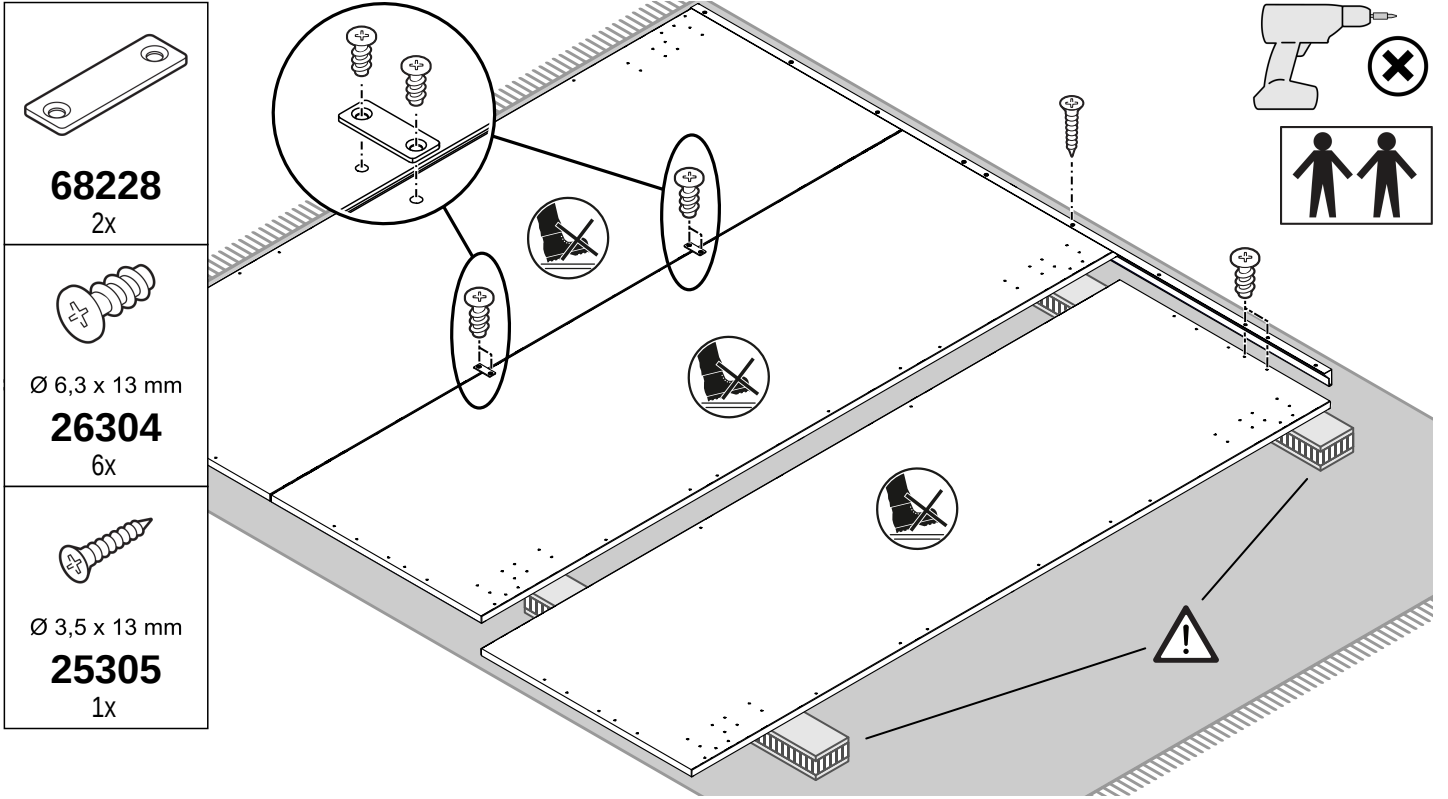

10.4

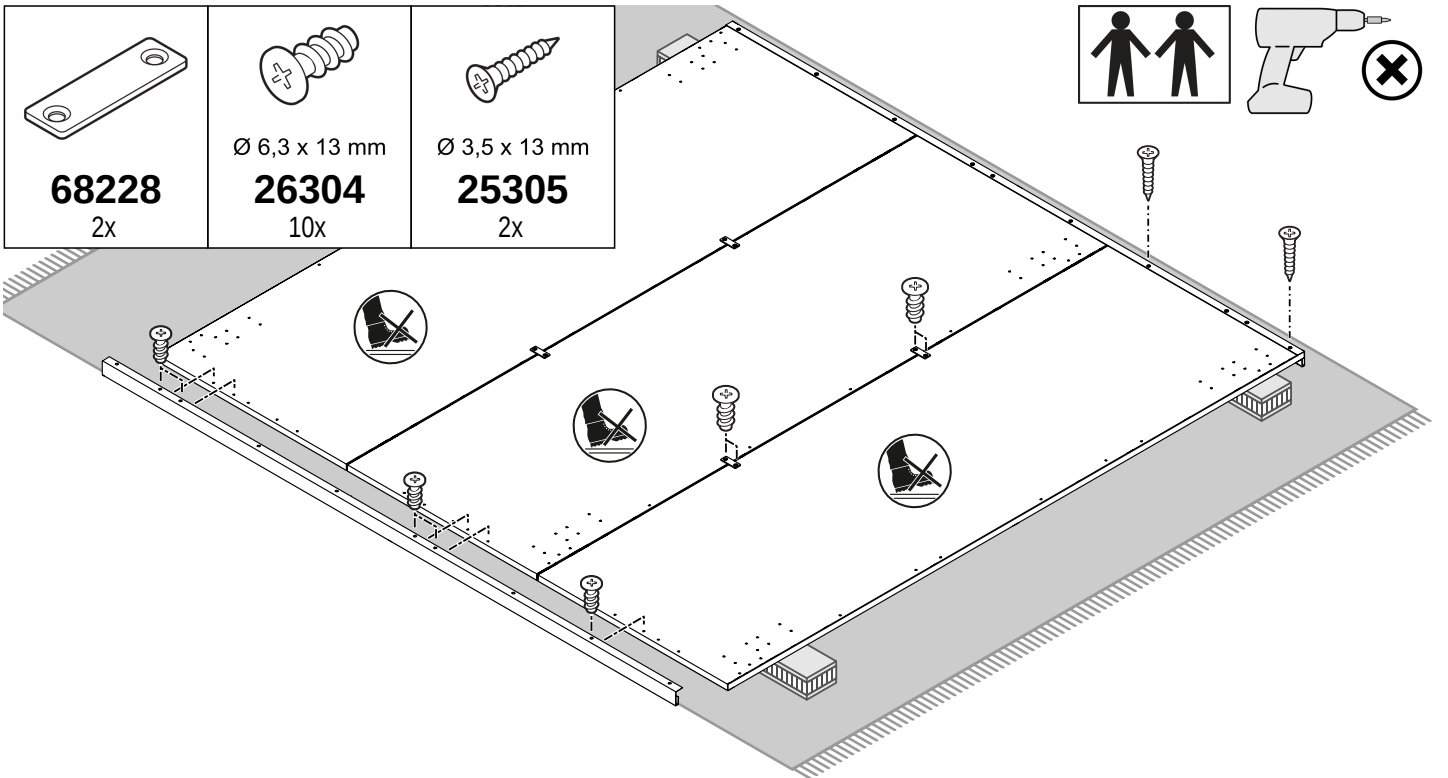

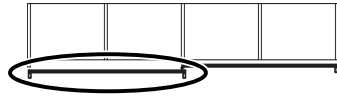

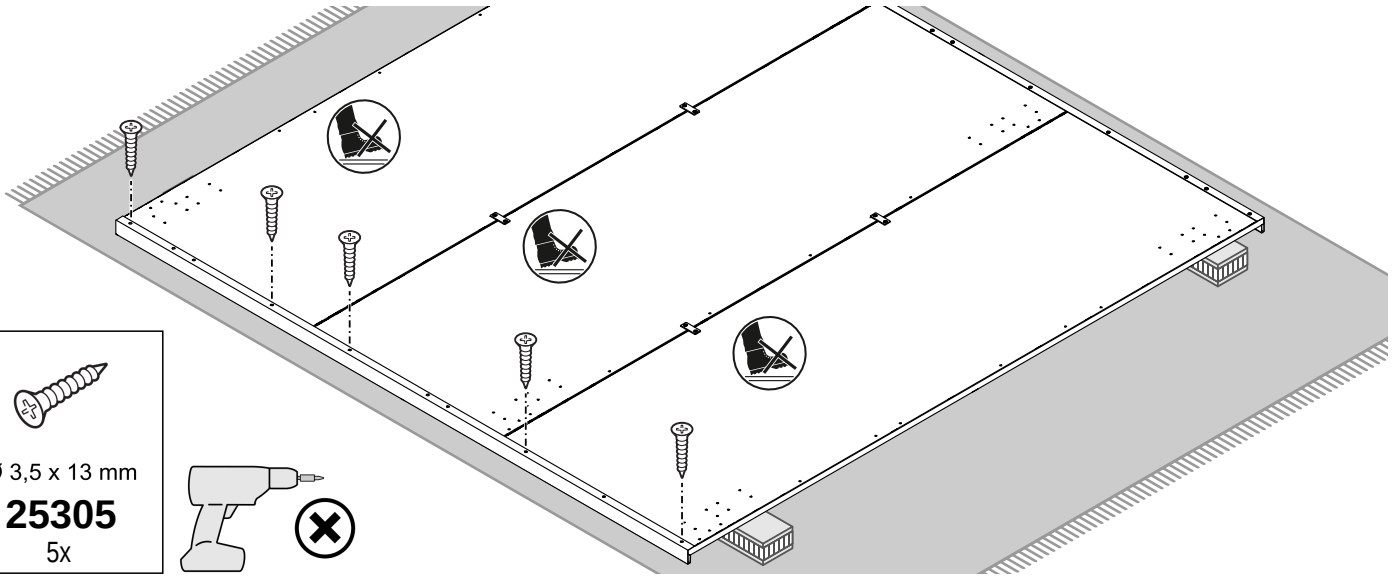

10.5



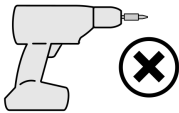

Ø 3,5 x 13 mm
25305
5x

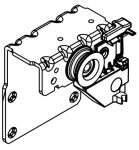
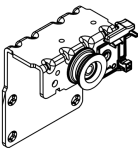
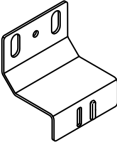

10.6

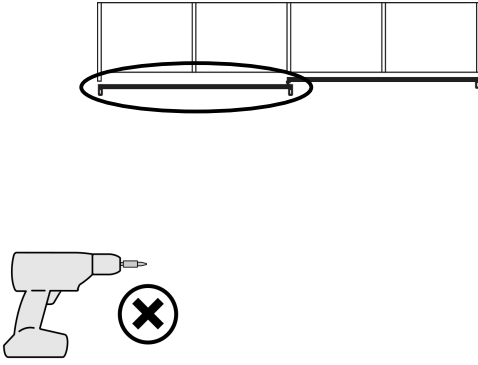
 <p>95594 1x</p>	 <p>93647 1x</p>
 <p>34649 2x</p>	 <p>Ø 6,3 x 13 mm 26304 12x</p>

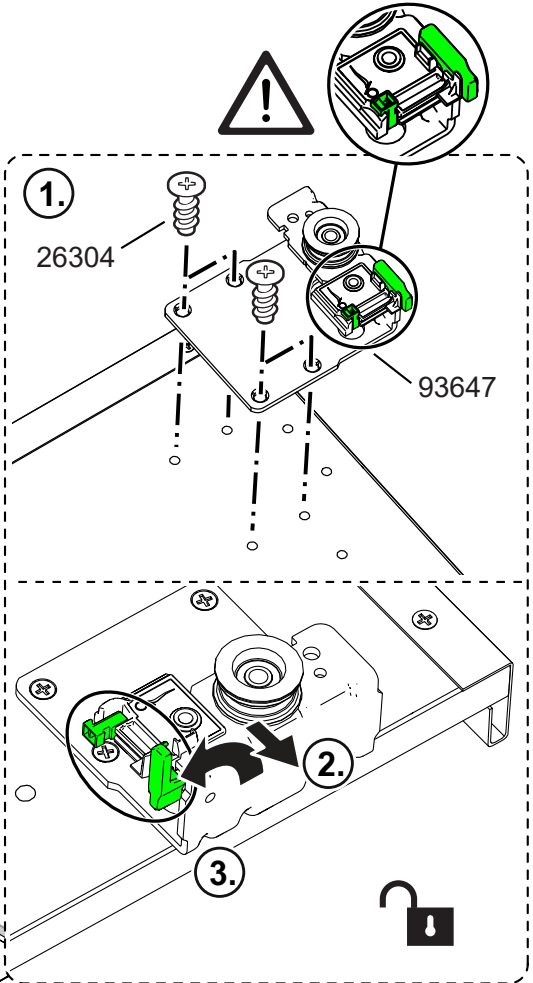



1. 26304 93647

2.

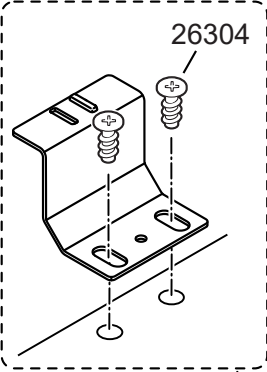

26304

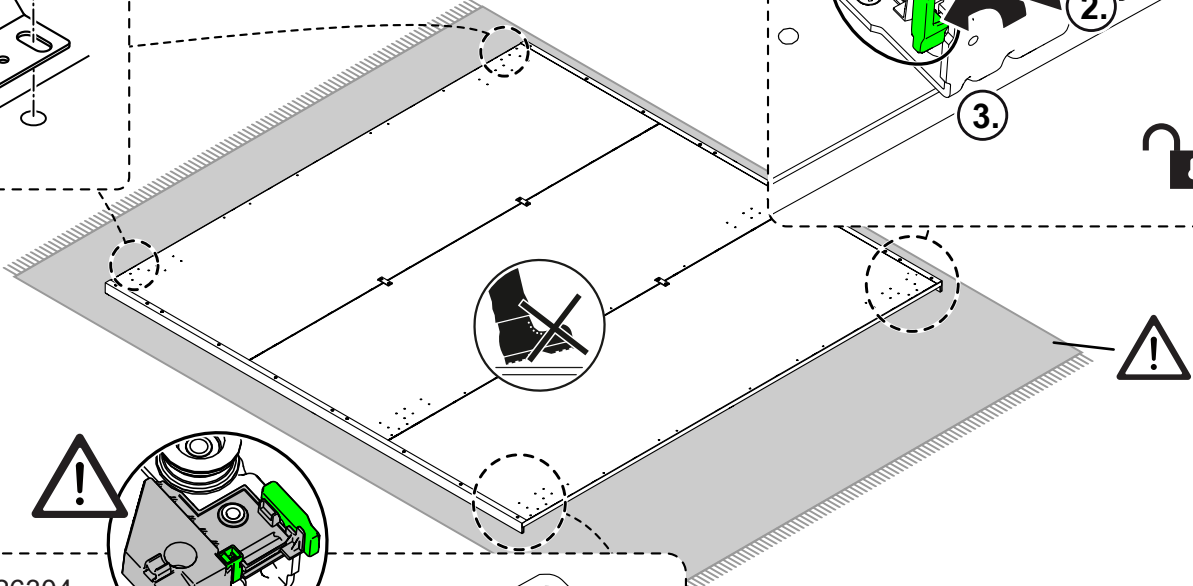

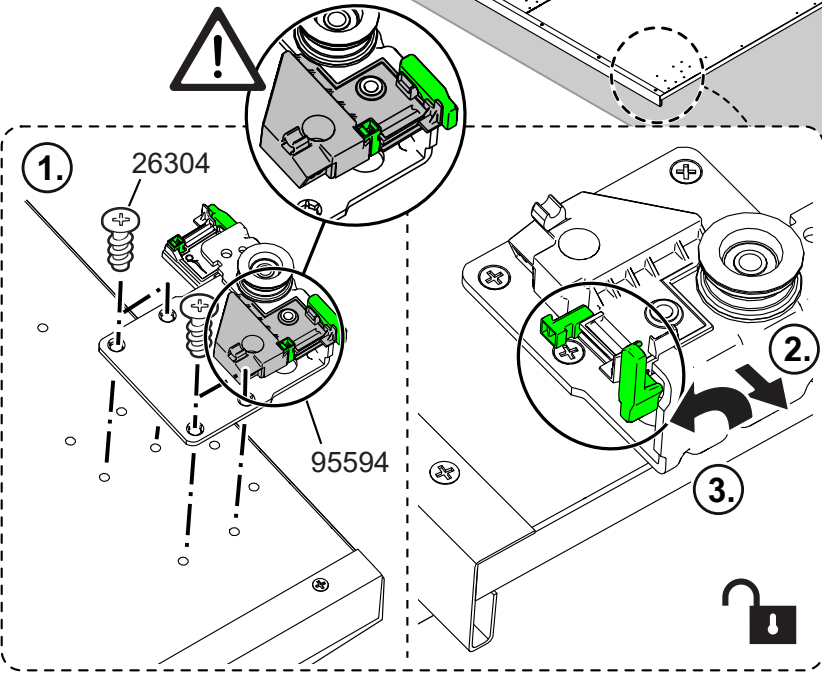

1. 26304 95594

2.

3.

11.

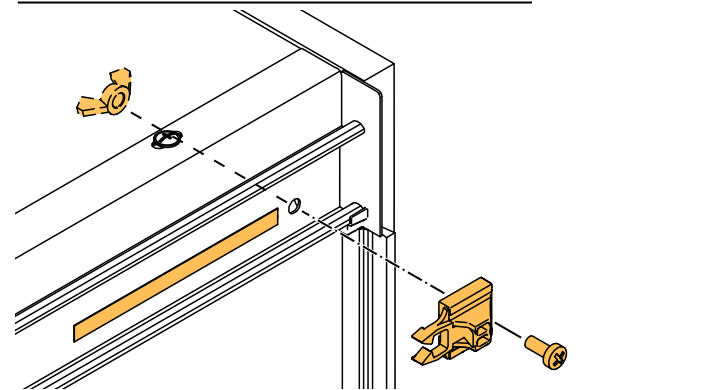
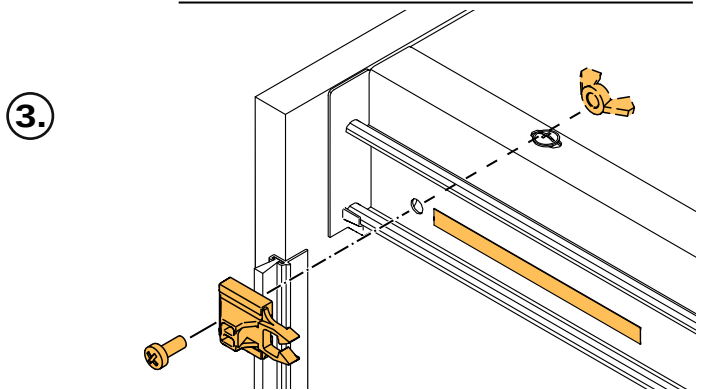
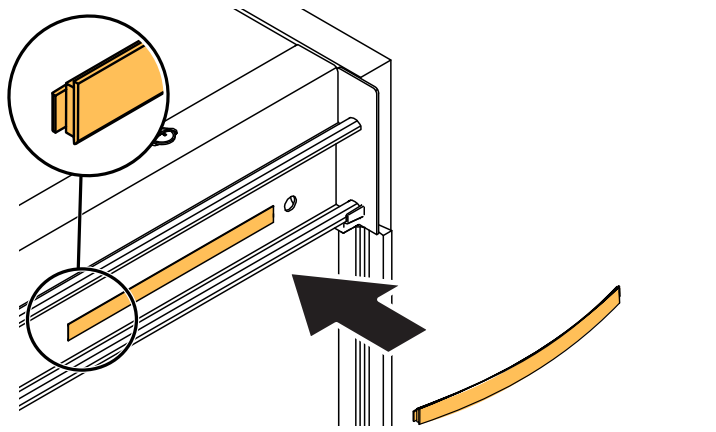
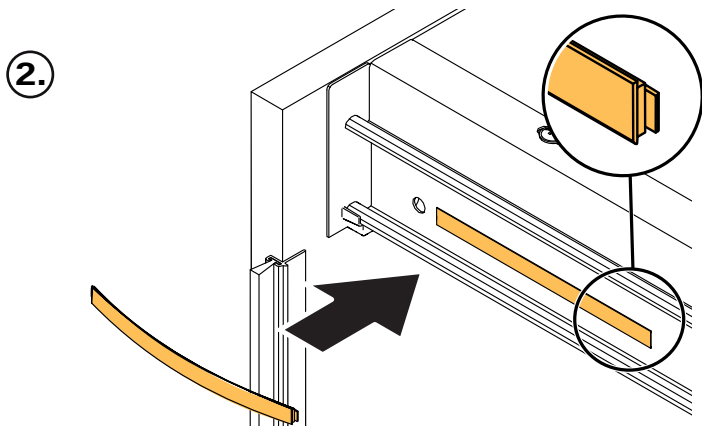
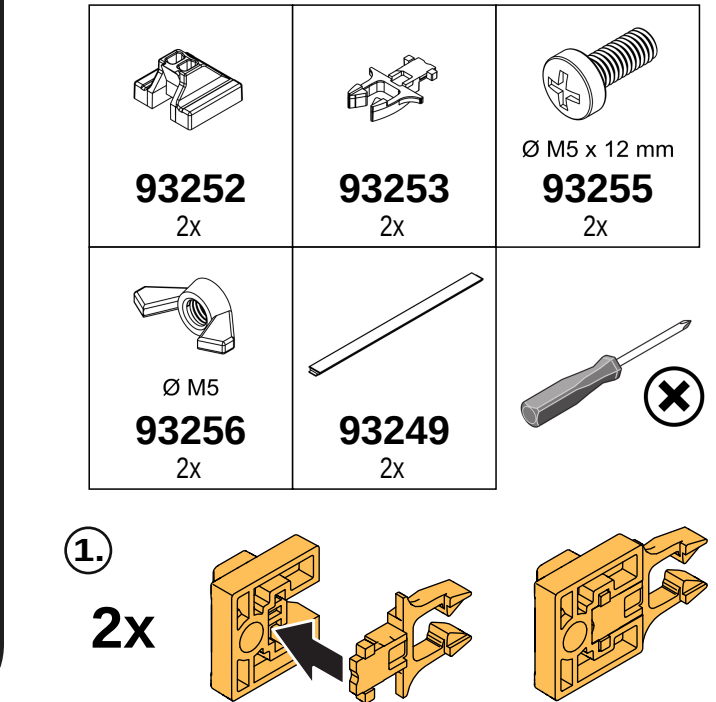
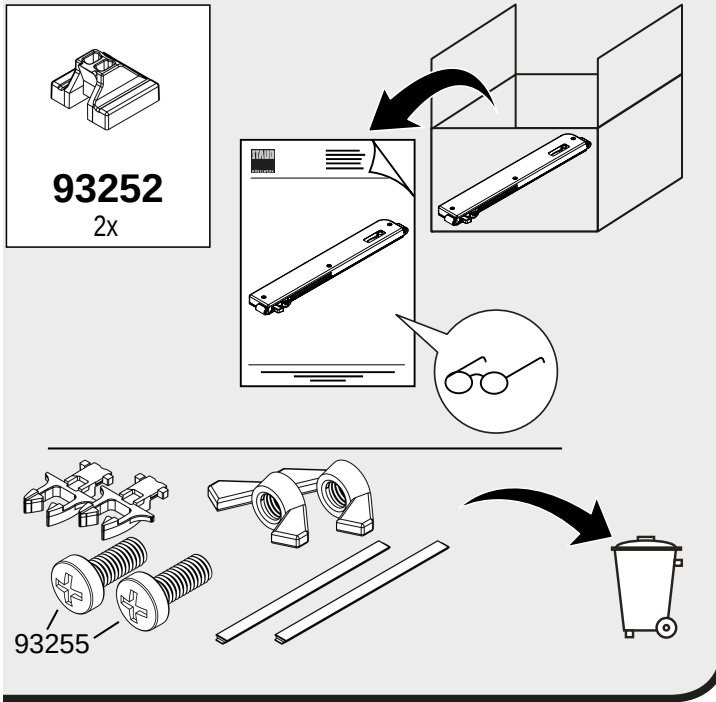

12.1

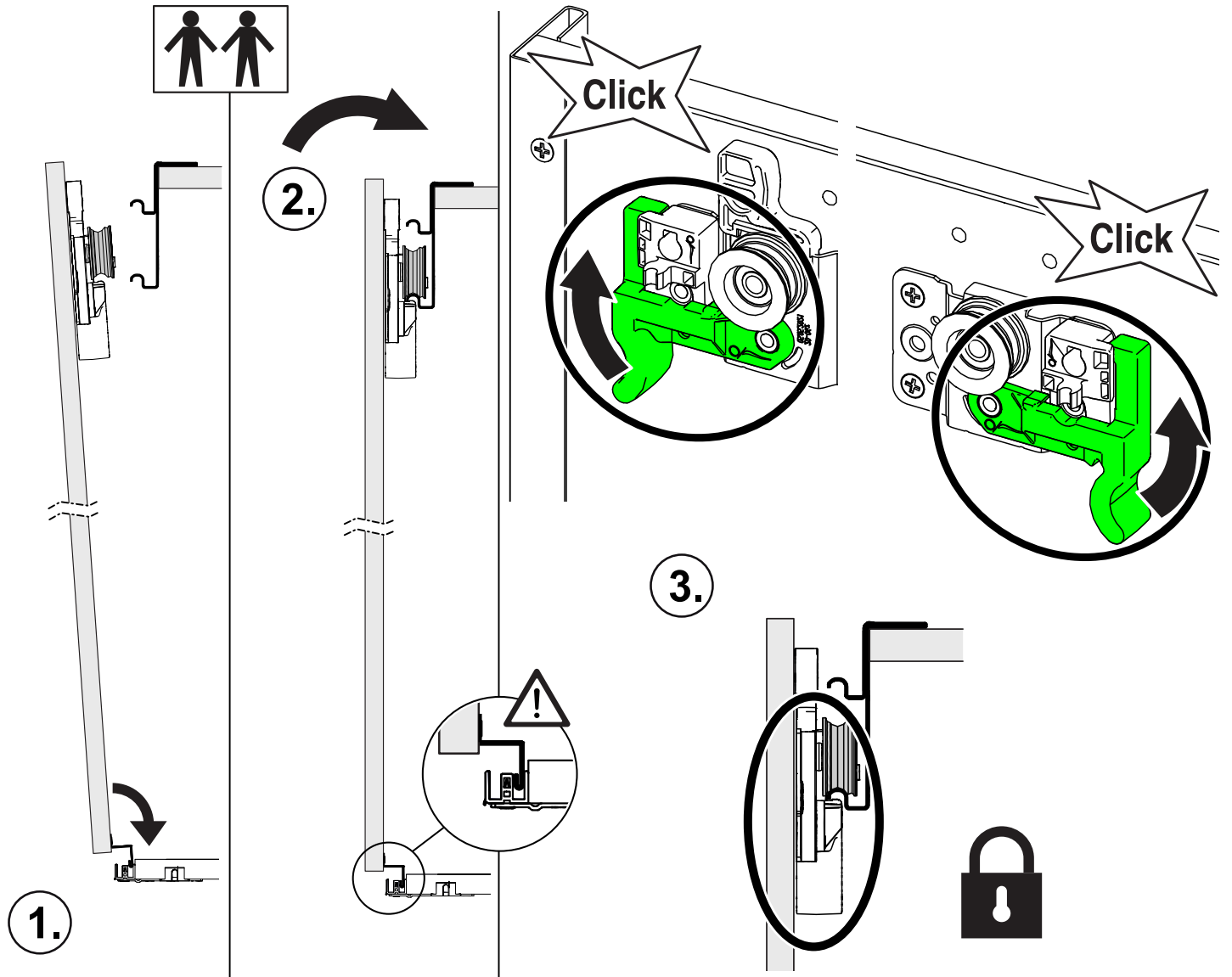

4.

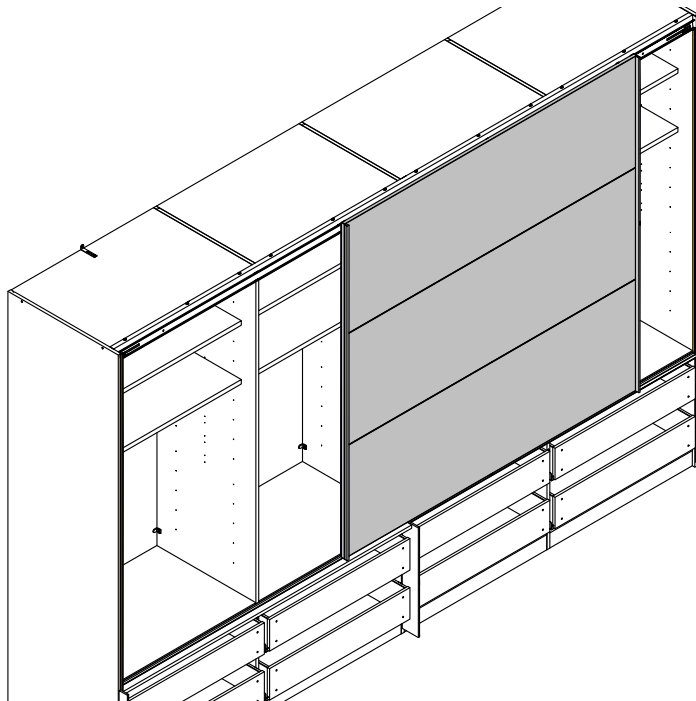

12.2

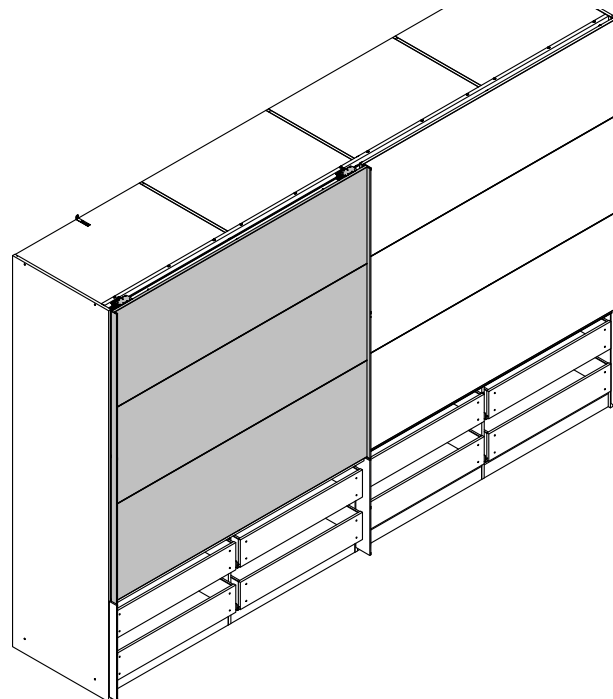
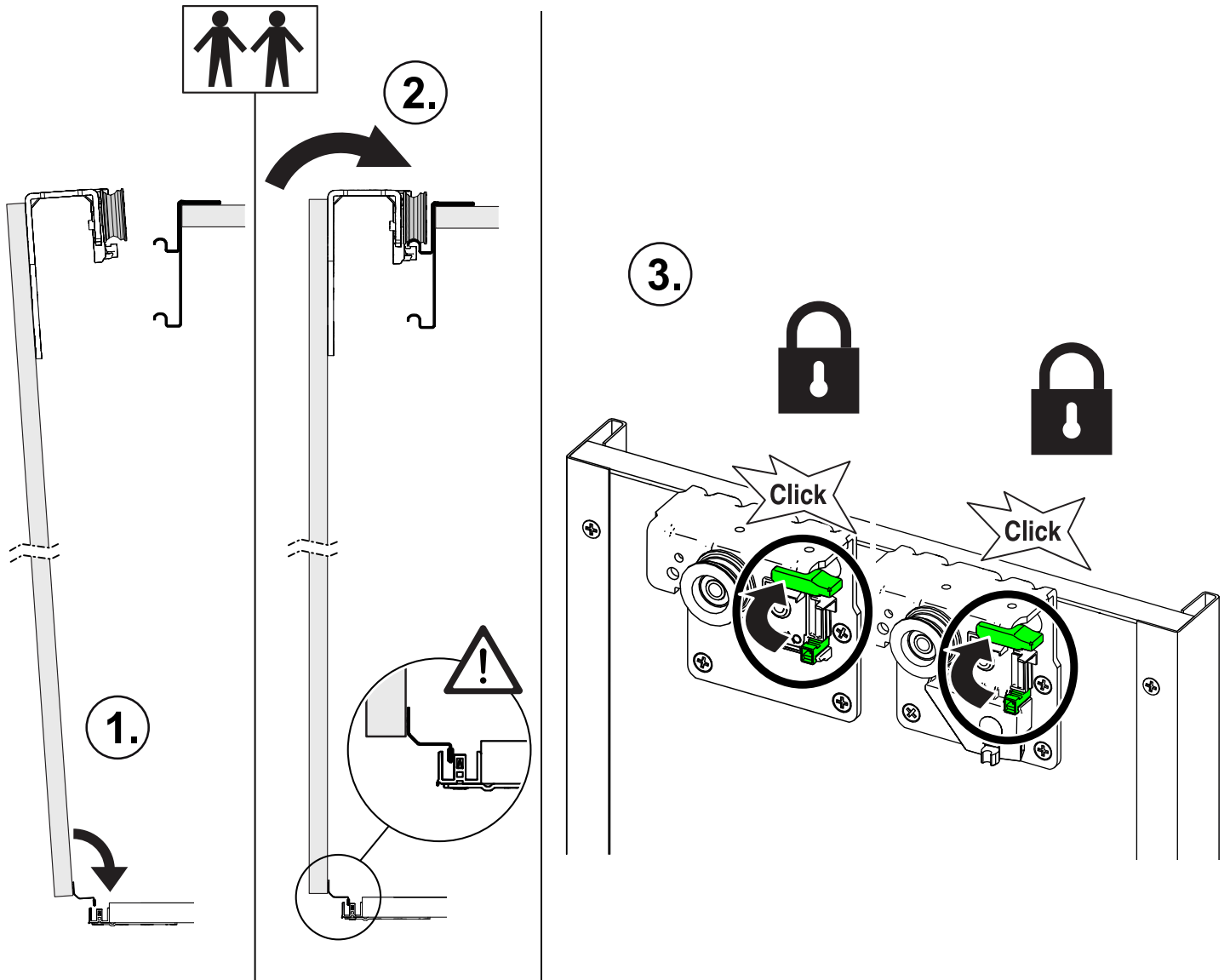

13.1

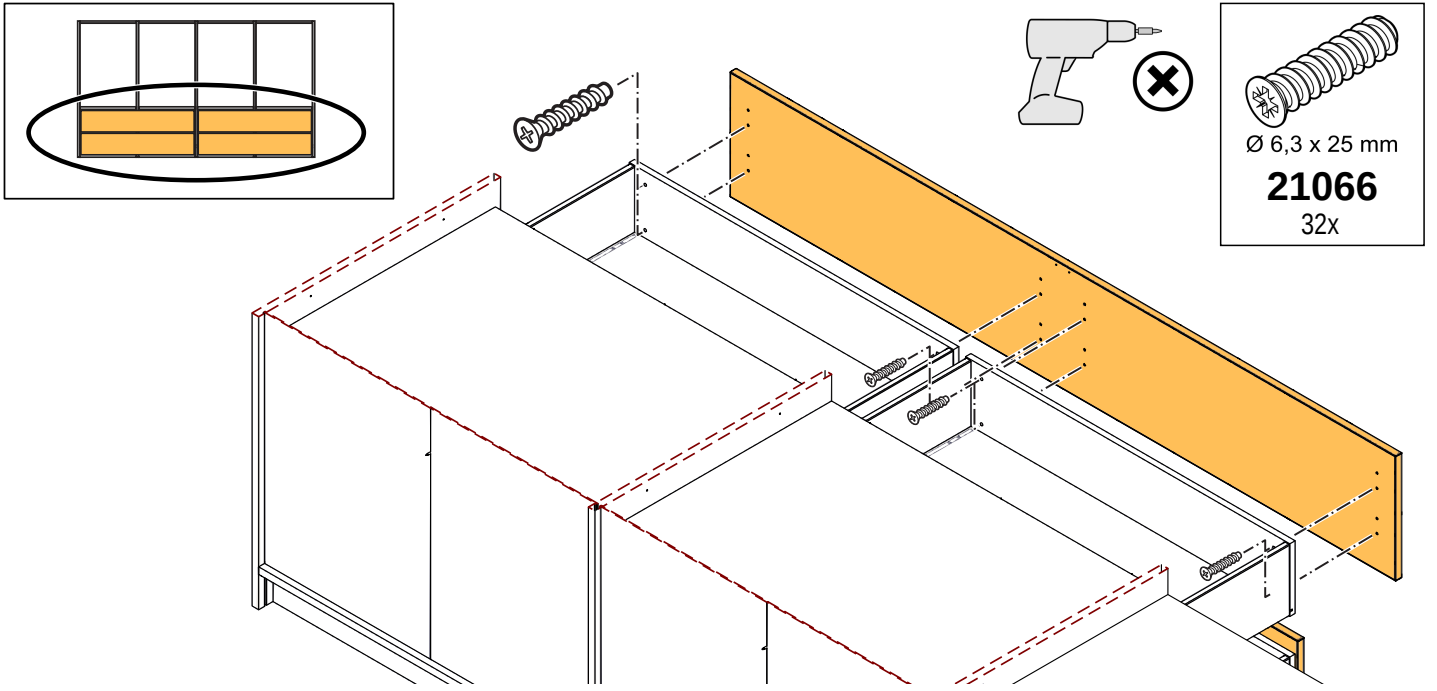

13.2

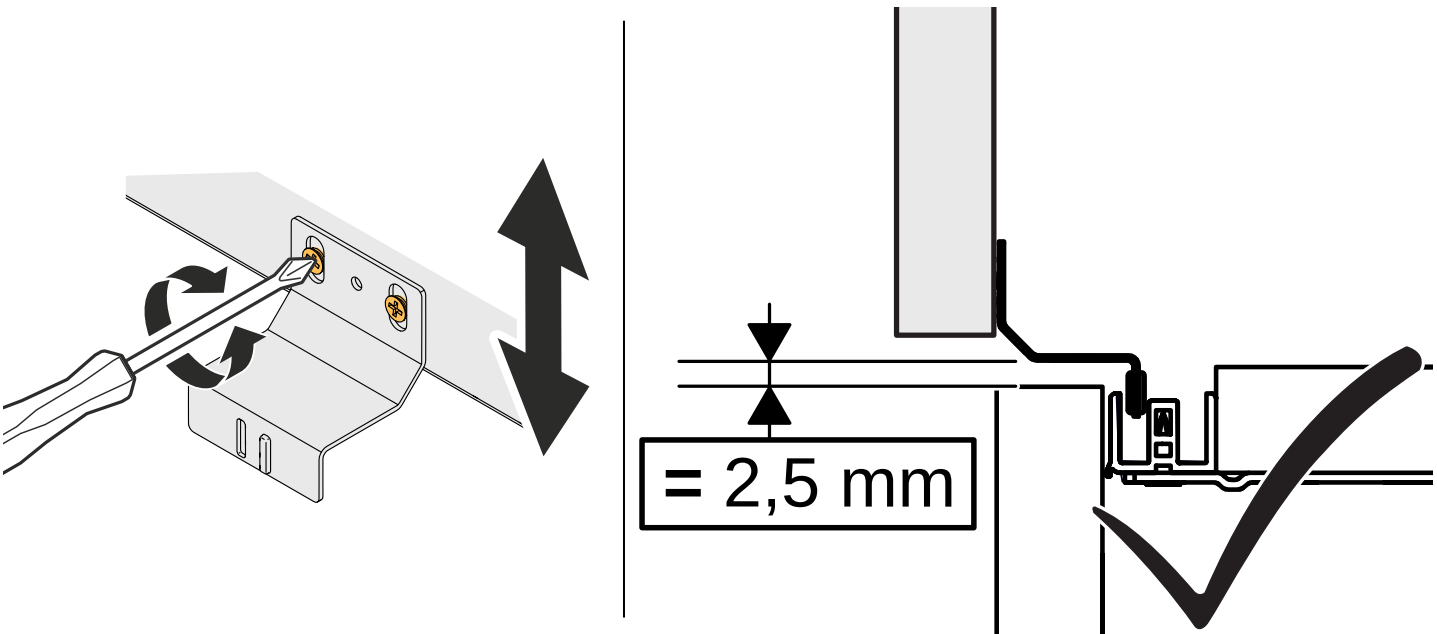
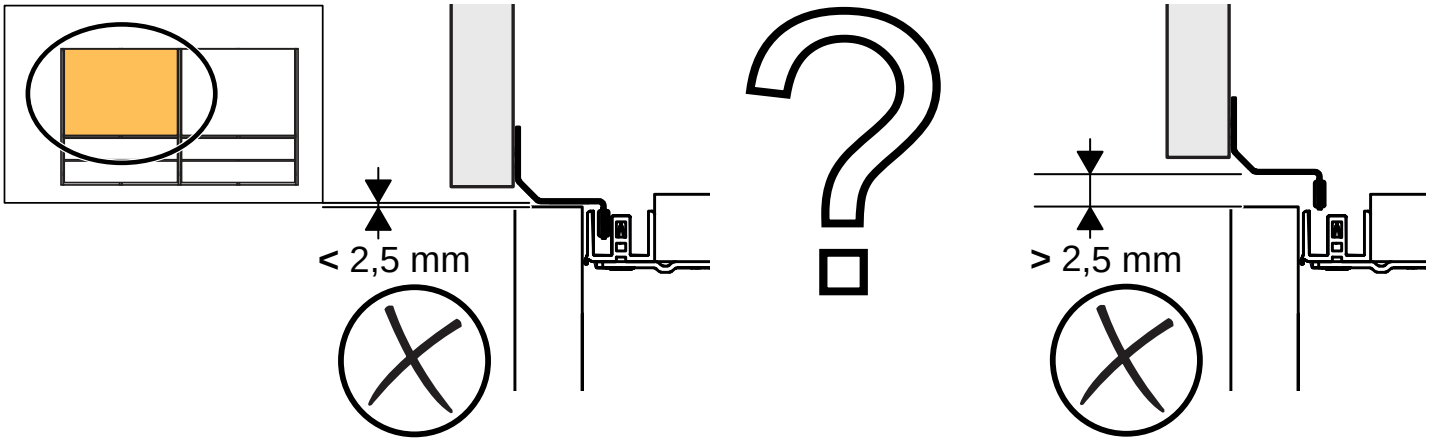

13.3

