

# Joker

**Montageanleitung**

**Assembly instructions**

**Notice de montage**

**Istruzioni per il montaggio**

**Instrucciones de montaje**

**Инструкция по монтажу**

**组装说明**

02. 2020

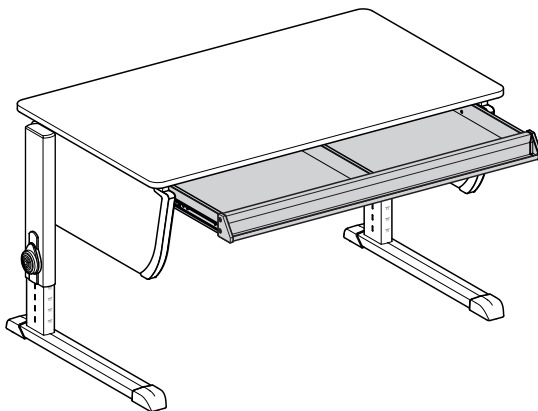
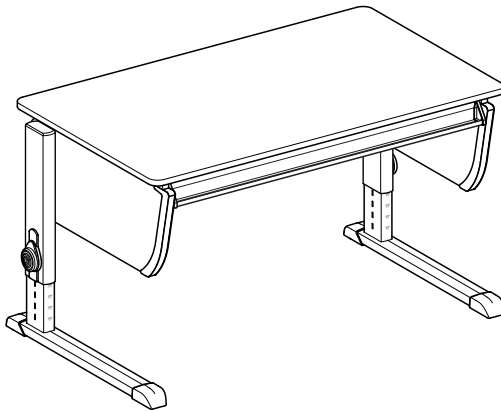

- + Schublade
- + Drawer
- + Tiroir
- + Cassetto
- + Cajón
- + Выдвижной ящик
- + 抽屉

## **D** Sicherheitshinweise

- ⚠ Die Montage darf nur durch geeignete Personen erfolgen.
- ⚠ Das Möbel darf nur für seinen bestimmungsgemäßen Gebrauch verwendet werden.
- ⚠ Achtung - nicht für Kinder unter 3 Jahren geeignet, enthält verschluckbare Kleinteile - Erstickungsgefahr

## **GB** Safety instructions

- ⚠ Assembly may only be made by qualified persons.
- ⚠ The furniture is only to be used for its intended purpose.
- ⚠ Warning - not suitable for children under 3 years, contains small parts - choking hazard

## **F** Consignes de sécurité

- ⚠ Le montage doit être confié uniquement à des personnes compétentes.
- ⚠ Ce meuble doit servir exclusivement à l'usage qui en est fait habituellement.
- ⚠ Attention - ne convient pas aux enfants de moins de 3 ans, contient petites pièces - risque d'étouffement

## **I** Norme di sicurezza

- ⚠ Fare eseguire il montaggio esclusivamente da persone idonee.
- ⚠ Utilizzare questo mobile esclusivamente per l'uso previsto.
- ⚠ Attenzione - non adatto ai bambini sotto di 3 anni, contiene piccole parti - rischio di soffocamento

## **E** Indicaciones de seguridad

- ⚠ El montaje sólo podrá ser ejecutado por personas aptas para el mismo.
- ⚠ El mueble sólo podrá ser utilizado para un uso conforme a lo prescrito.
- ⚠ Advertencia - no apto para niños menores de 3 años, contiene pequeñas piezas - peligro de asfixia

## **RUS** Указания по безопасности

- ⚠ Монтаж должен выполняться только лицами, имеющими необходимые навыки.
- ⚠ Мебель должна использоваться только по ее прямому назначению.
- ⚠ Внимание - Не подходит для детей в возрасте до 3 лет, содержит мелкие детали - удушья

## **CHN** 安全提示

- ⚠ 组装需要由专业人员完成。
- ⚠ 家具的使用要合理，要符合其用途。
- ⚠ 注意 - 不适合3岁以下儿童，小件可能被吞下 - 窒息危险

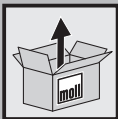

Alles auspacken und Inhalt auf Vollständigkeit prüfen

Unpack the contents and check for completeness

Déballez tout et vérifiez que le contenu est bien complet

Togliere la fornitura dall'imballo e accertarsi che non ci siano pezzi mancanti

Joker

02. 2020

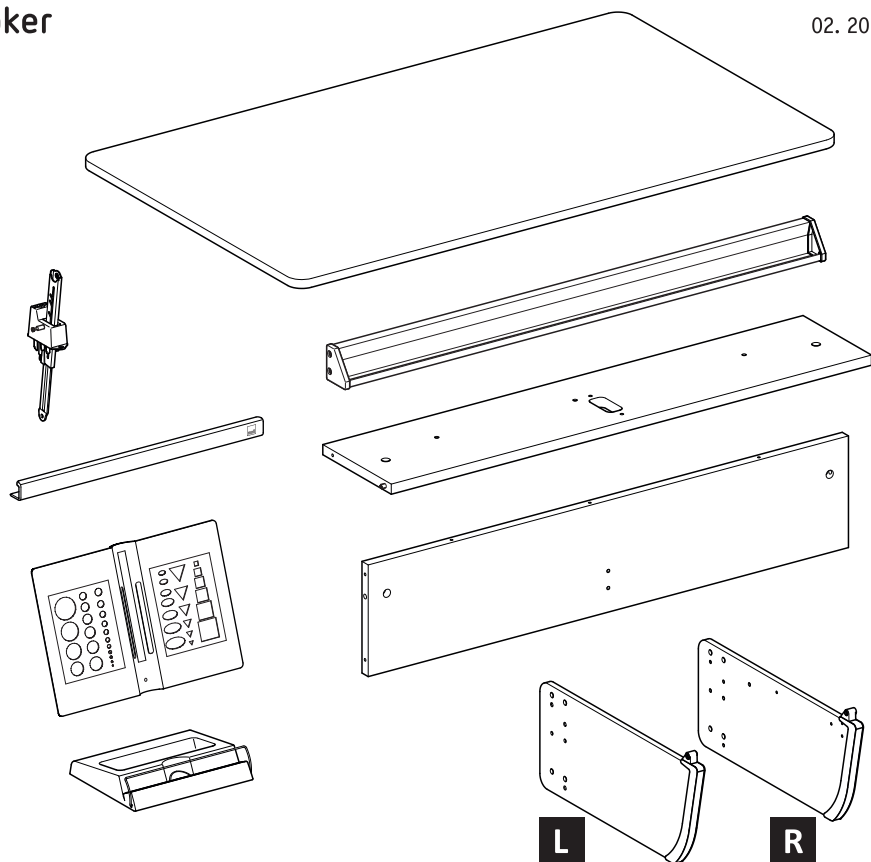

Schublade

Drawer

Tiroir

Cassetto

Cajón

Выдвижной ящик

抽屉

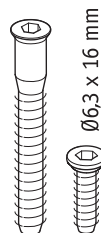
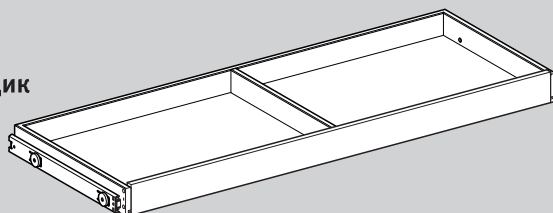

4x

4x

Desempaque todos los elementos y compruebe que no falta ninguno  
 Все распаковать и проверить содержимое на комплектность  
 拆开所有包装并检查是否齐全

- (D) Die Schrauben in dieser Reihenfolge verwenden.
- (GB) Use the screws in this sequence.
- (F) Utilisez les vis dans cette séquence.
- (I) Utilizzare le viti in questa sequenza.
- (E) Utilizar los tornillos en esta secuencia.
- (RUS) Использовать винты в этой последовательности.
- (CHN) 照此顺序安装使用螺钉。

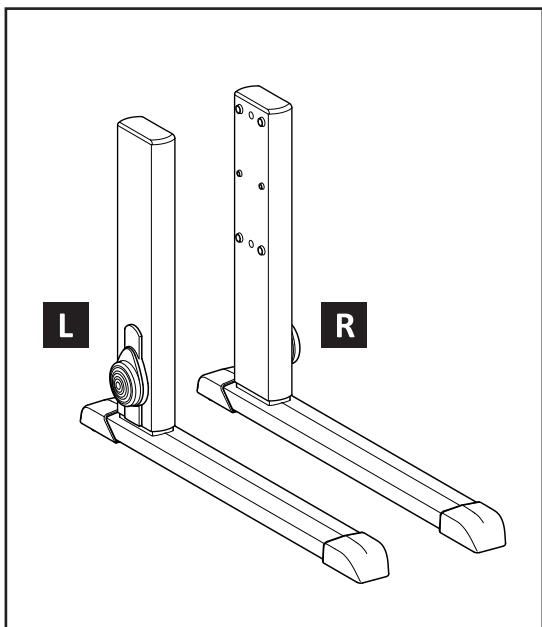
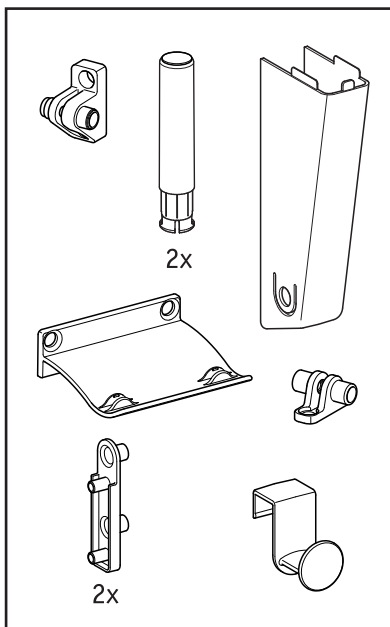
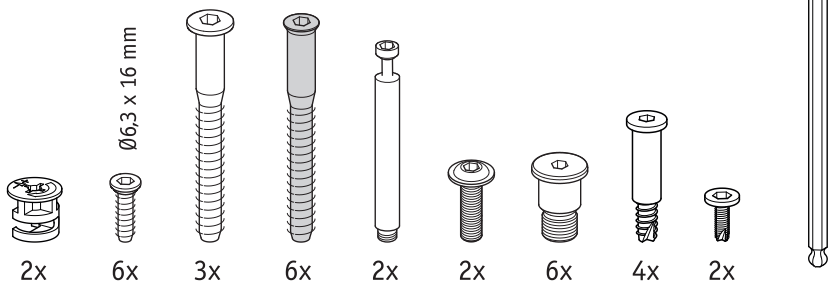

Montage Teil 1

Assembly Part 1

Montage partie 1

Montaggio parte 1

Montaje Parte 1

Монтаж Часть 1

组装 第1部分

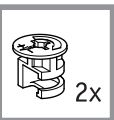
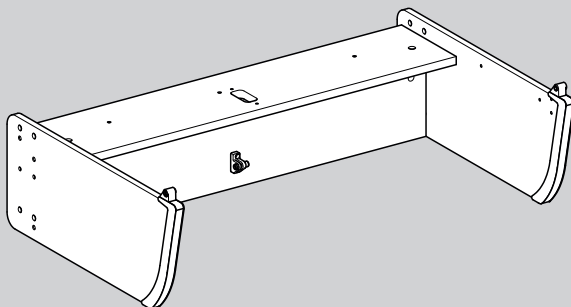

1

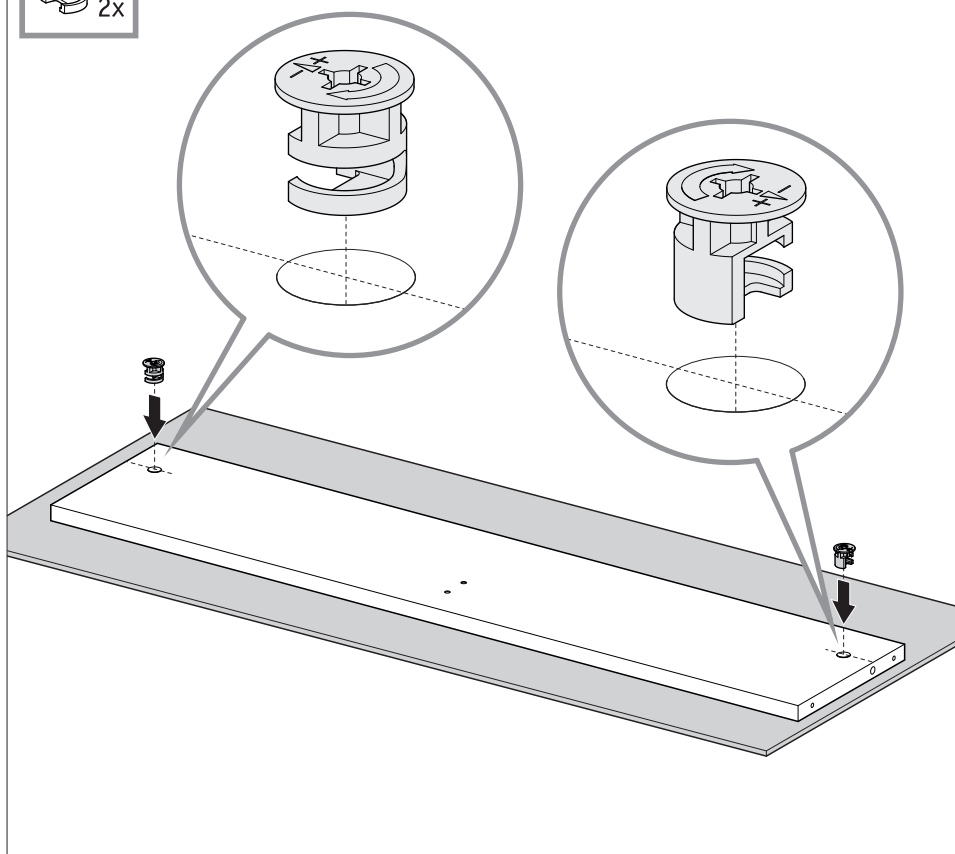

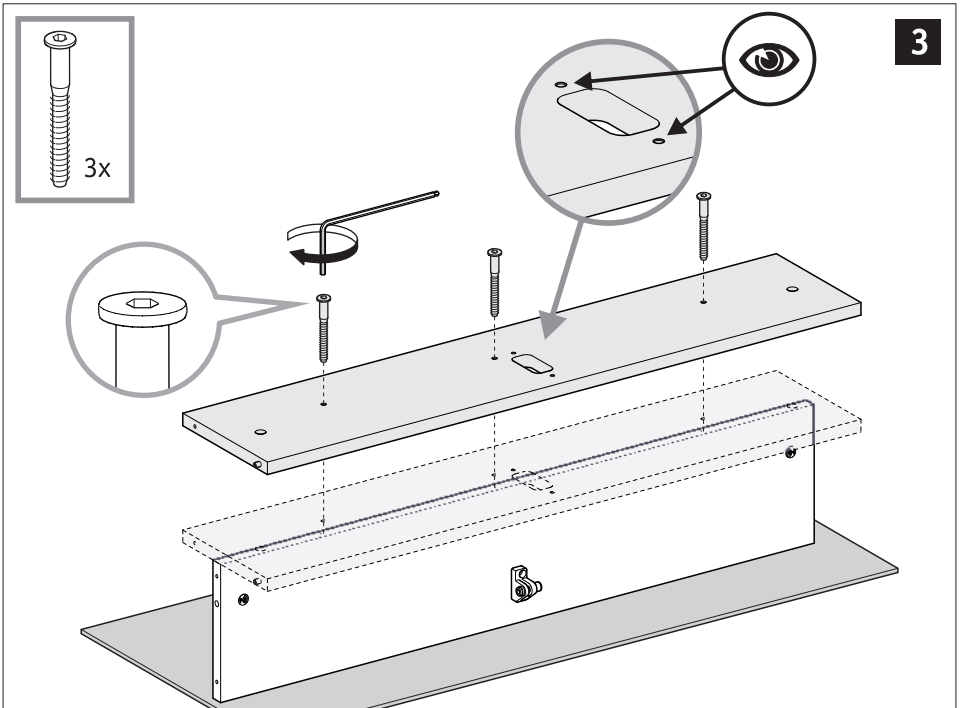
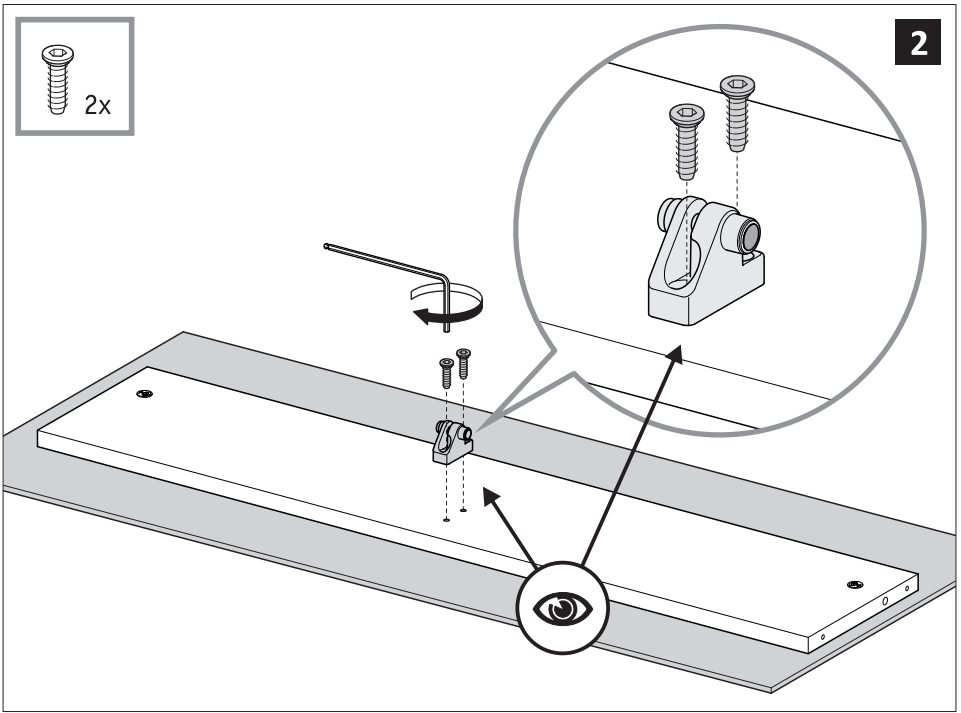

4

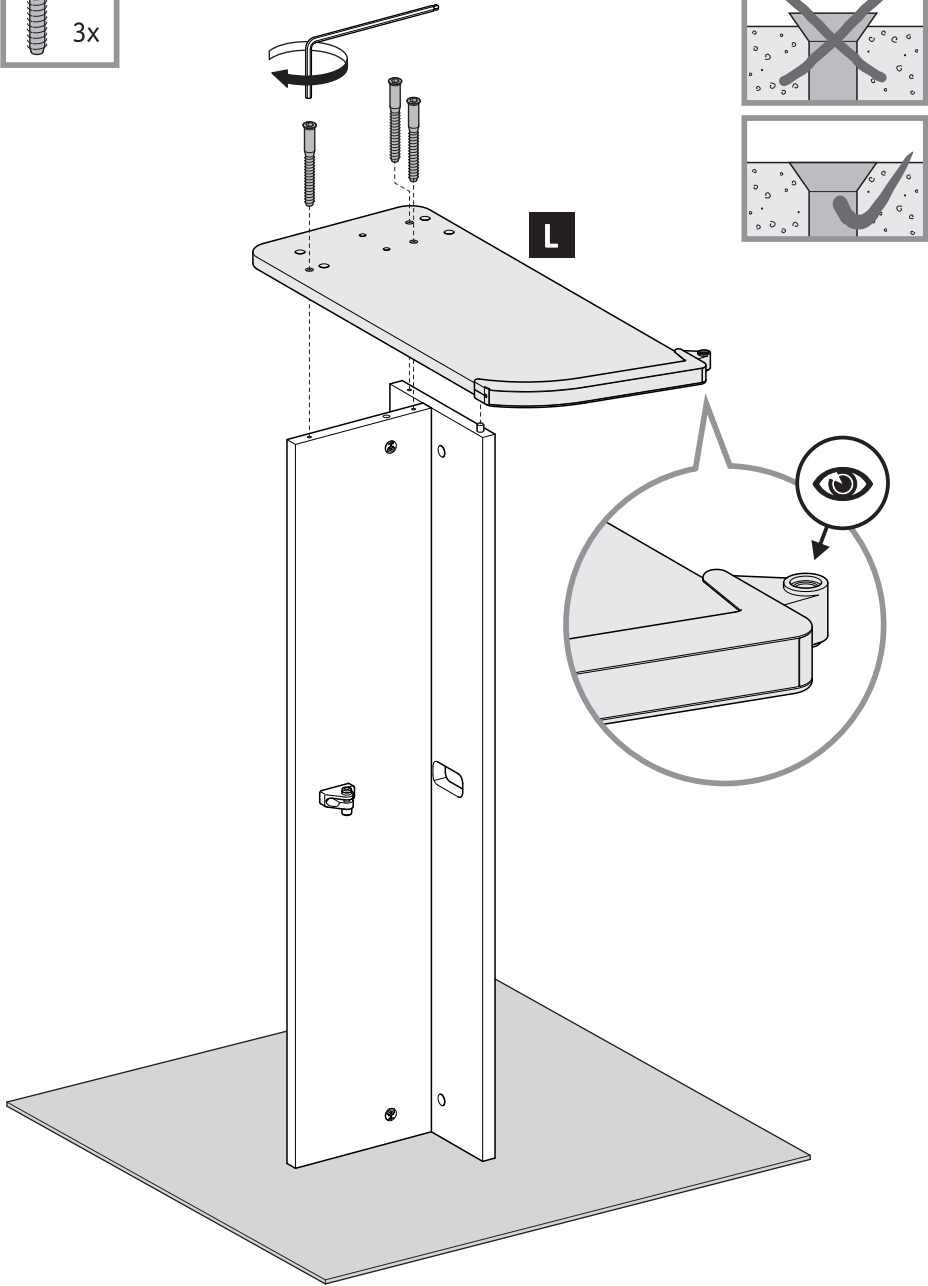
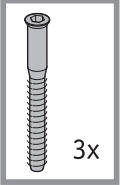

5

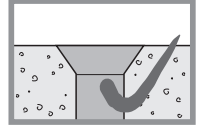
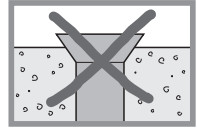
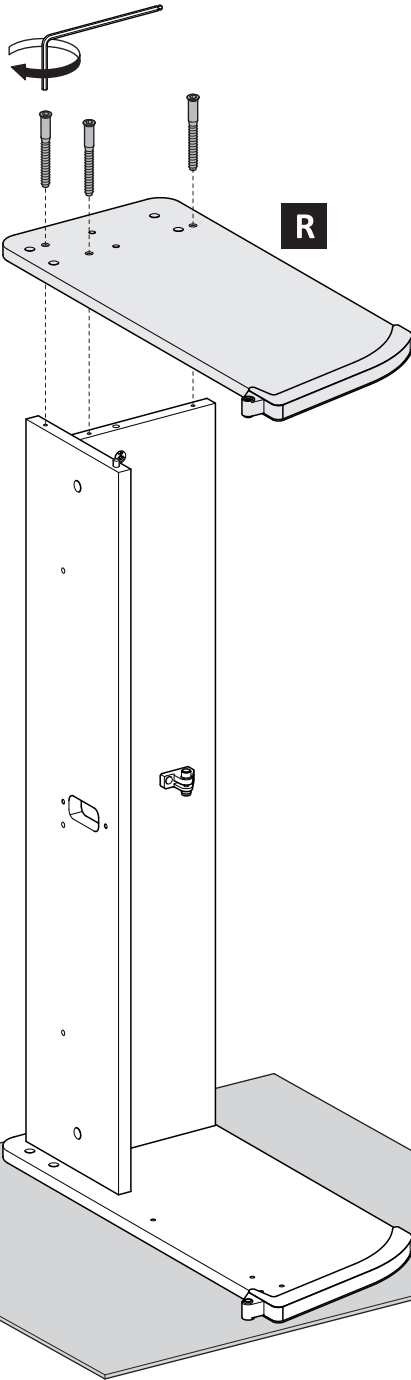
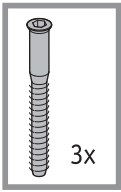

Montage Teil 2  
Fußmontage

Assembly Part 2  
Attaching the feet

Montage partie 2  
Montage des pieds

Montaggio parte 2  
Montaggio delle gambe

Montaje Parte 2  
Montaje de la pata

Монтаж Часть 2  
Монтаж ножек

组装 第2部分  
桌腿安装

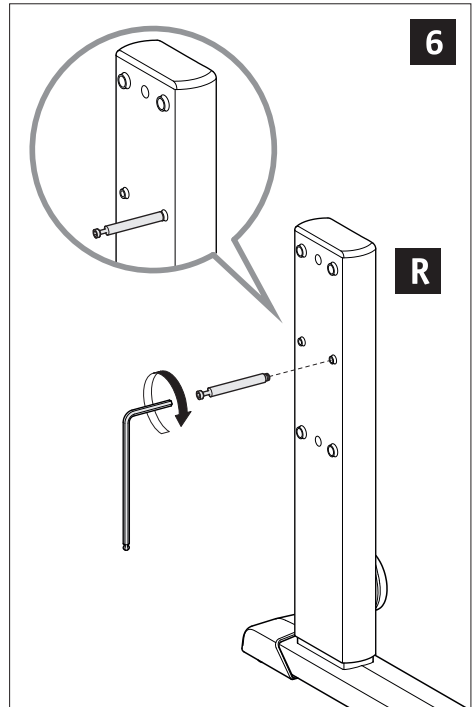
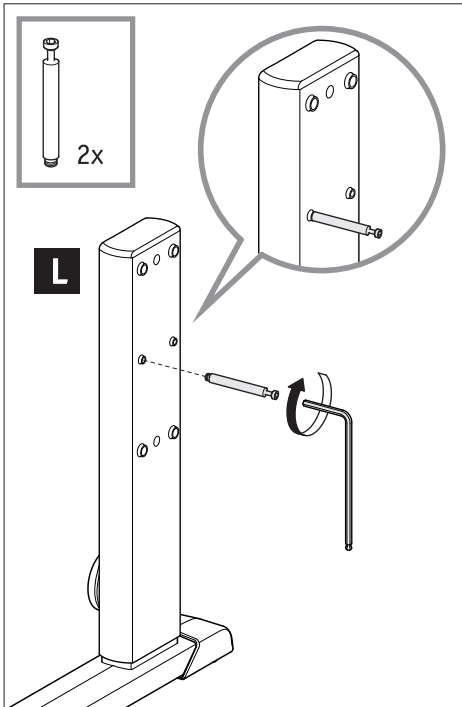
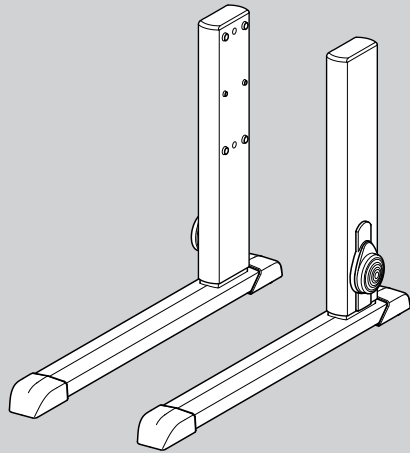

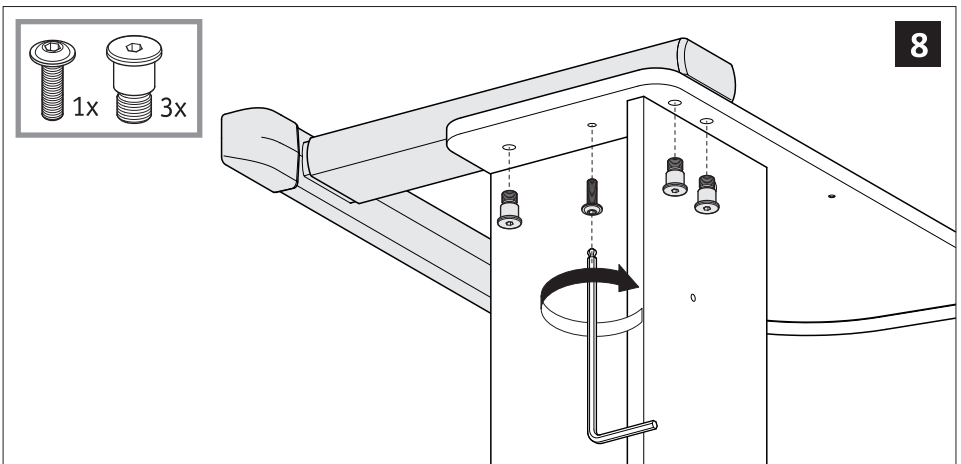
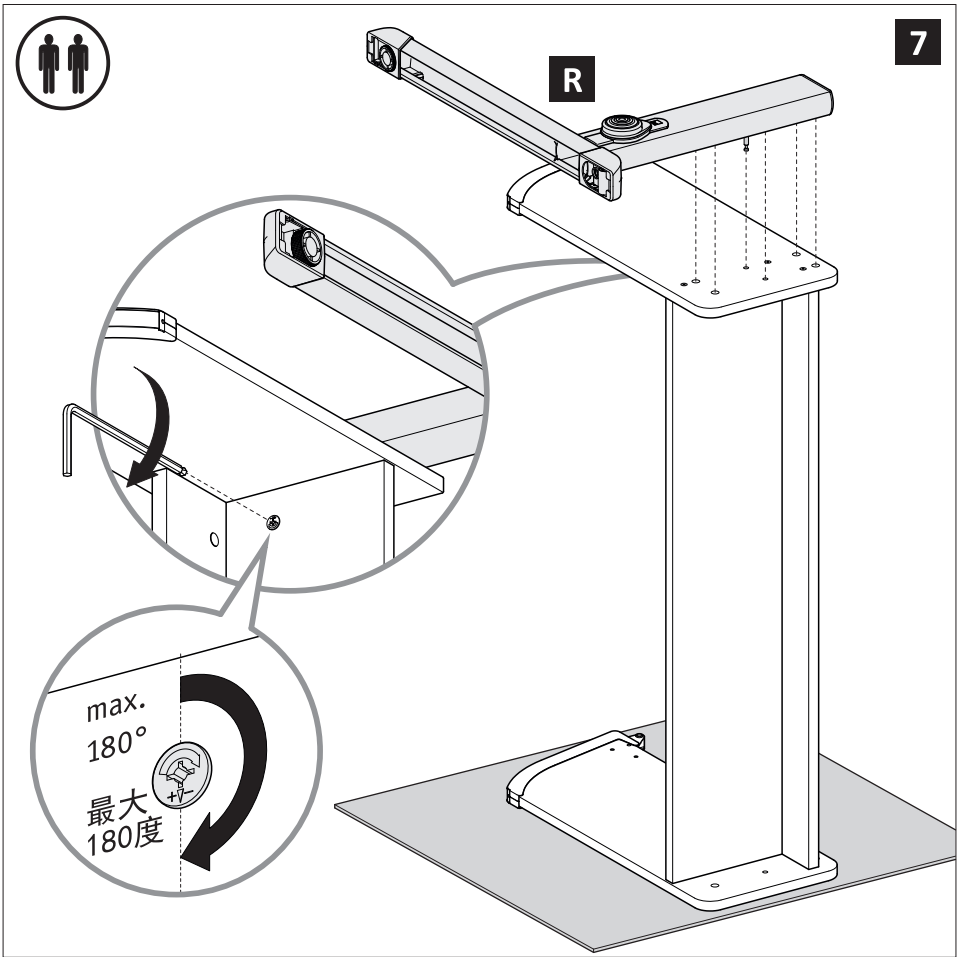

9

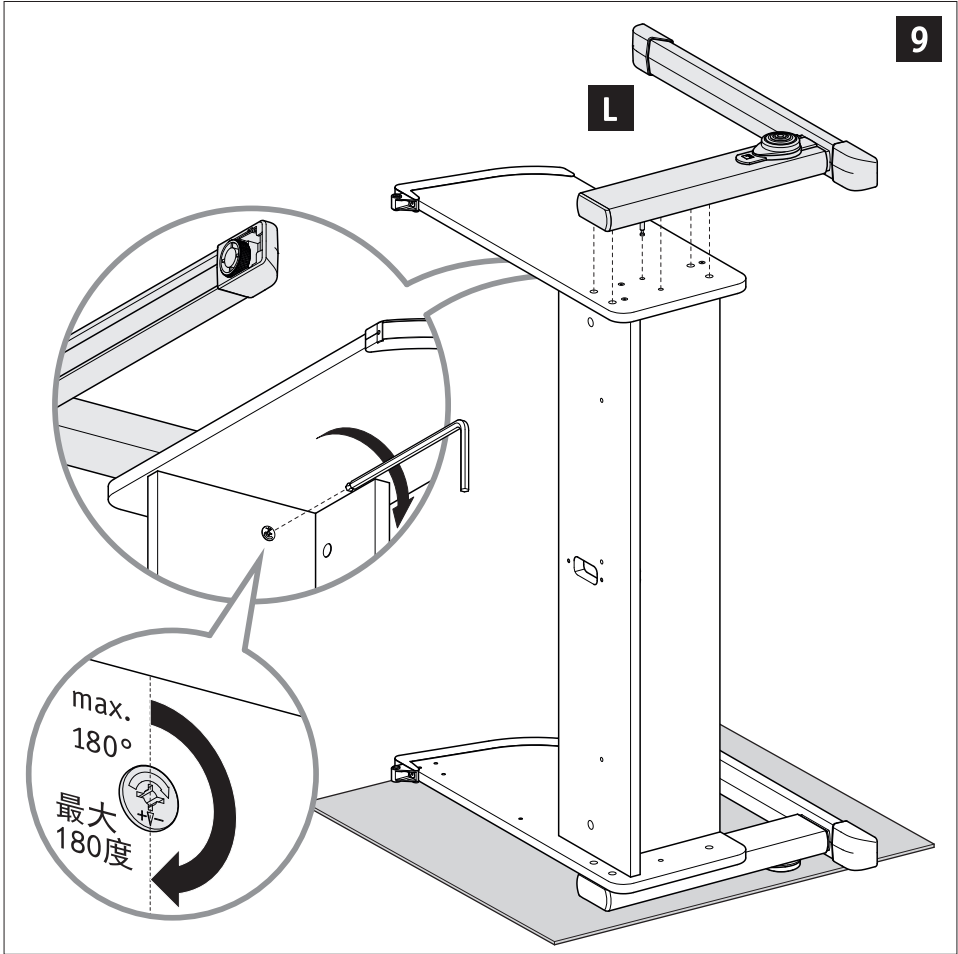

10

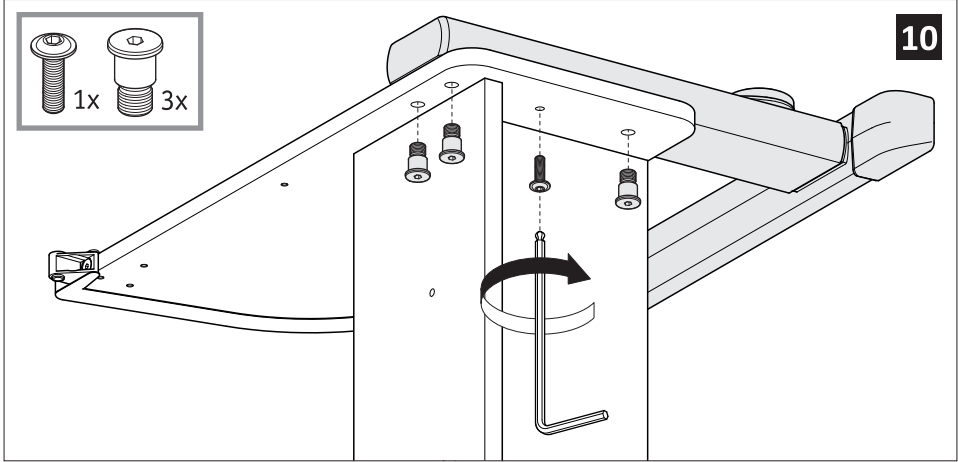

Montage Teil 3

Assembly Part 3

Montage partie 3

Montaggio parte 3

Montaje Parte 3

Монтаж Часть 3

组装 第3部分

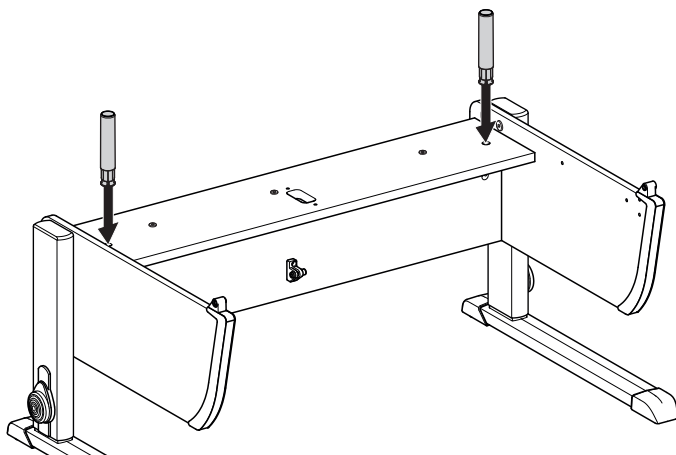
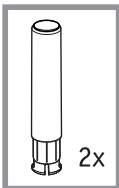
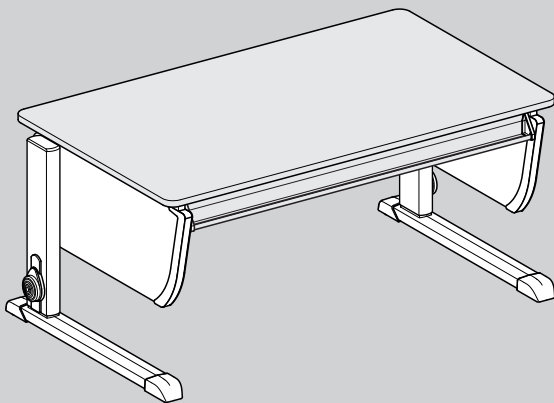

11

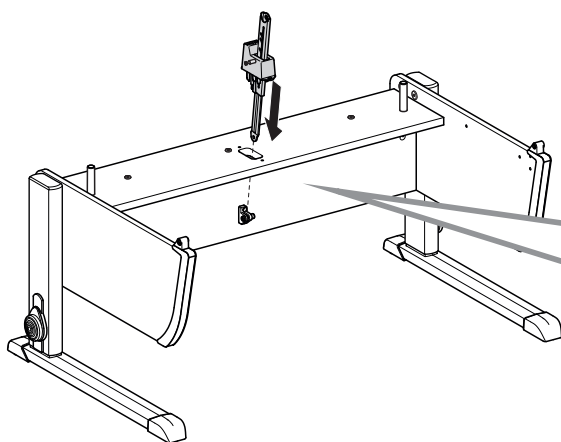

12

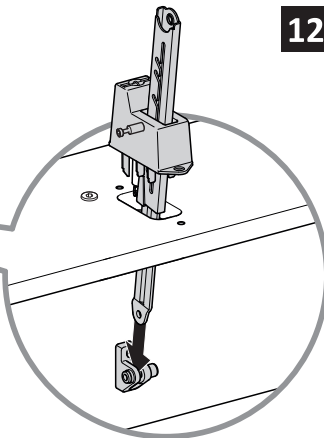

**13**

1x

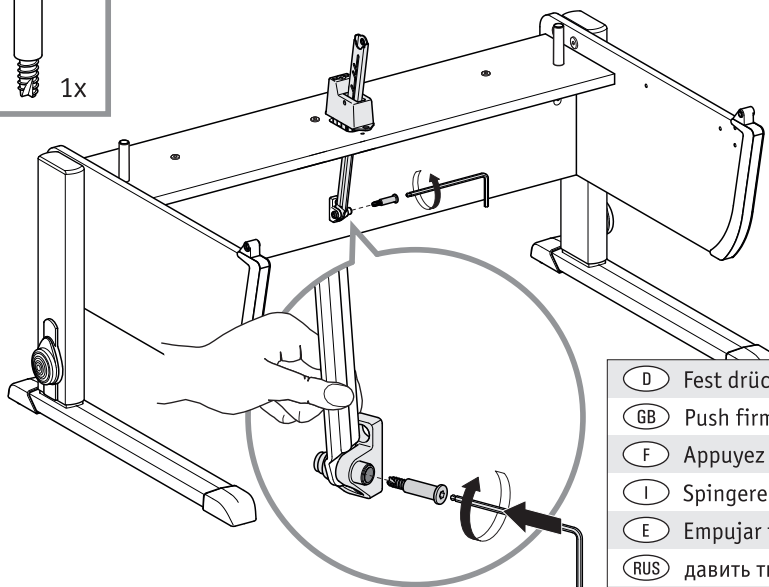

- D** Fest drücken.
- GB** Push firmly.
- F** Appuyez fermement.
- I** Spingere con fermezza.
- E** Empujar firmemente.
- RUS** давить твердо.
- CHN** 用力按

**14**

1x

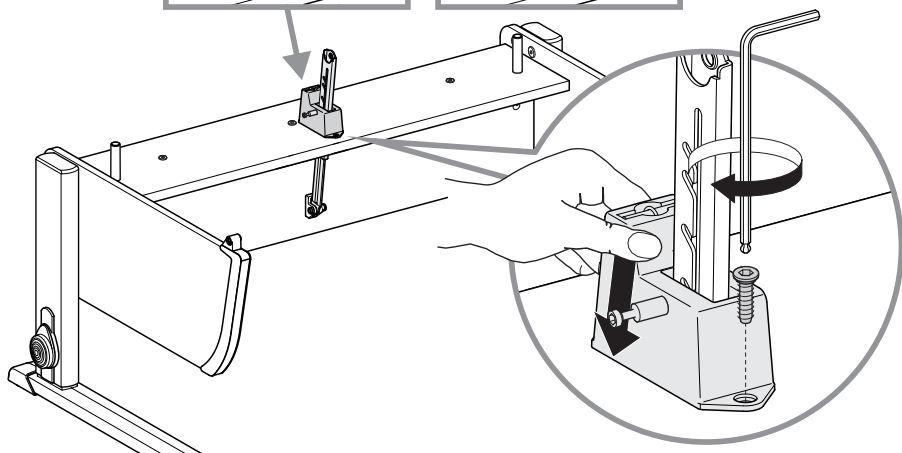
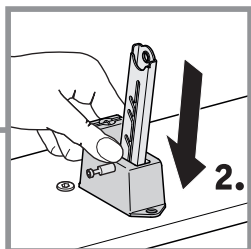
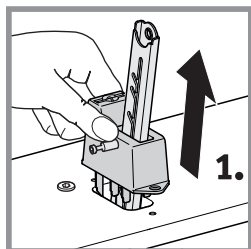

15



1x

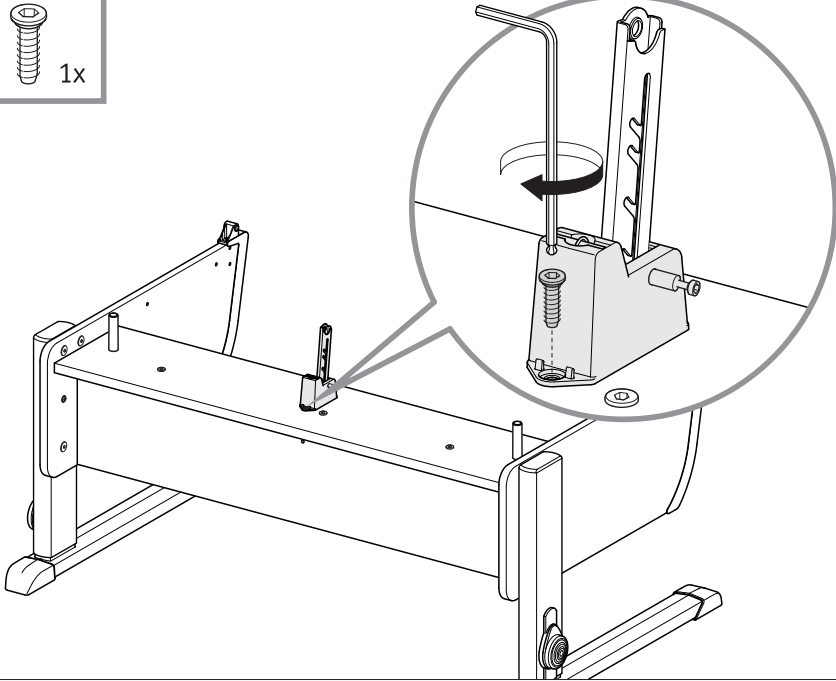

16

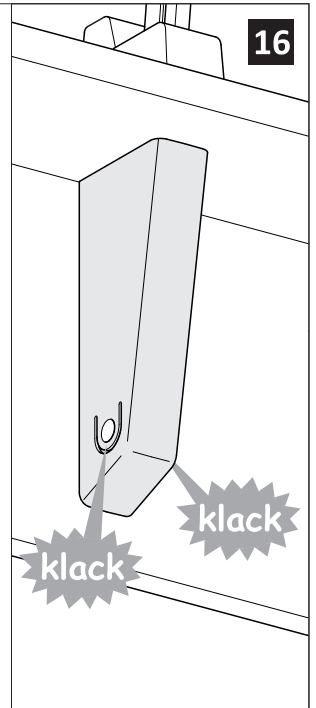
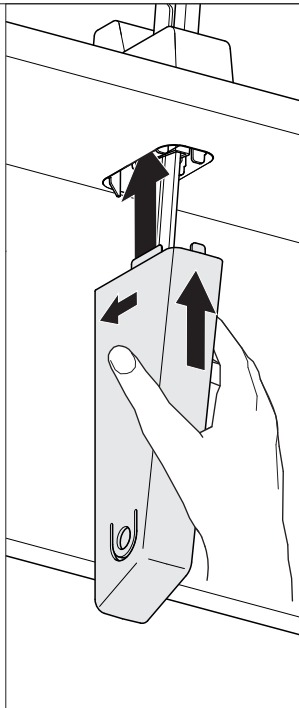
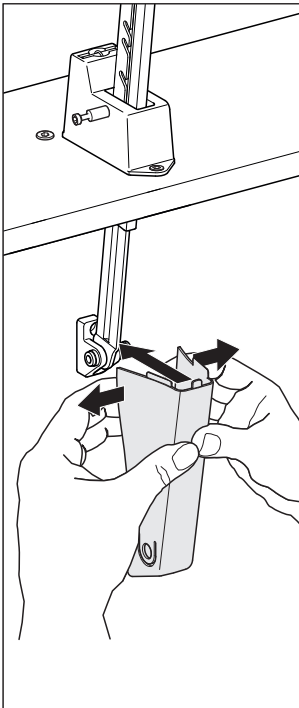

Schublade? → Ja

Drawer? → Yes

Tiroir? → Oui

Cassetto? → Sì

Cajón? → Si

Выдвижной ящик? → да

抽屉? → 是

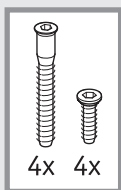
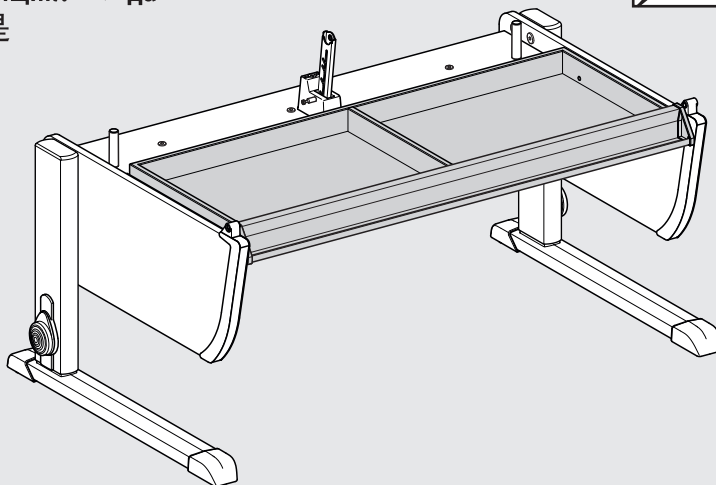
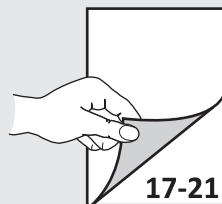

Stifteablage? → Ja

Pen holder? → Yes

Compartment à stylos? → Oui

Ripiano portapenna? → Sì

Bandeja portalápices? → Si

Откидной пенал? → да

笔盒? → 是

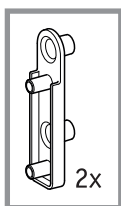
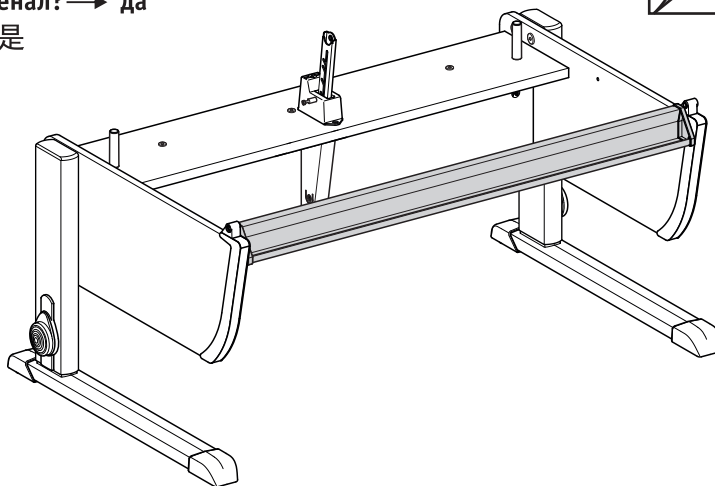
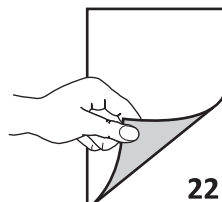

1.

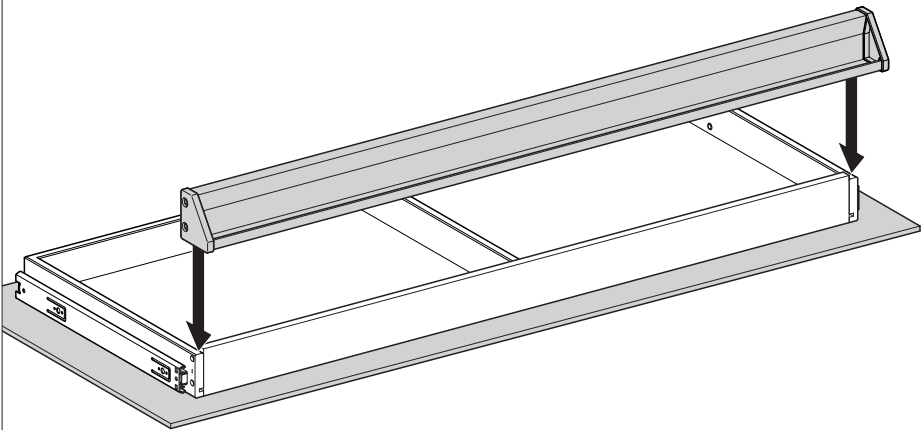

2.

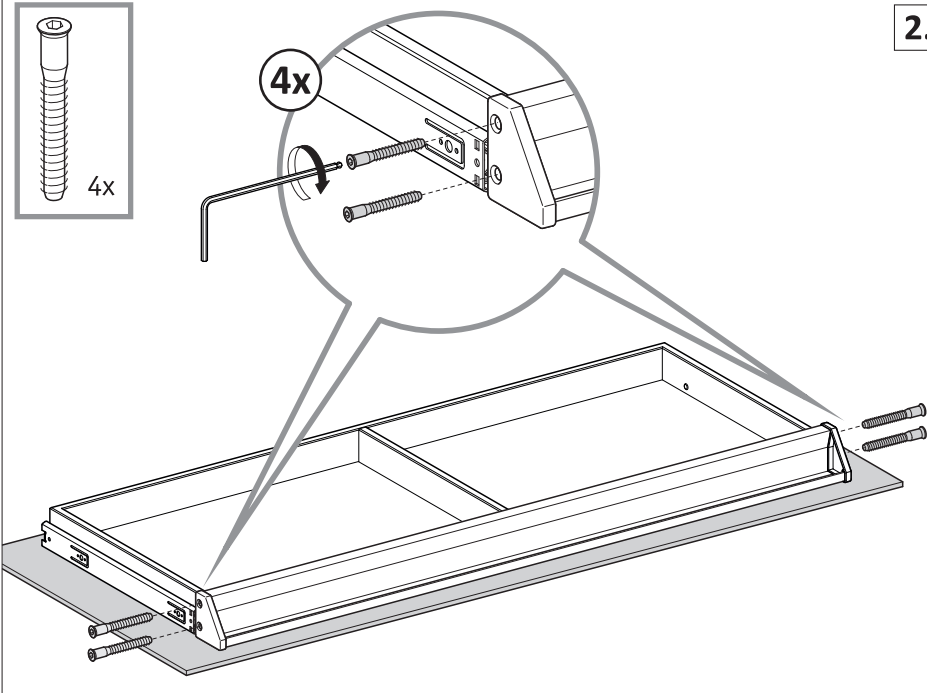

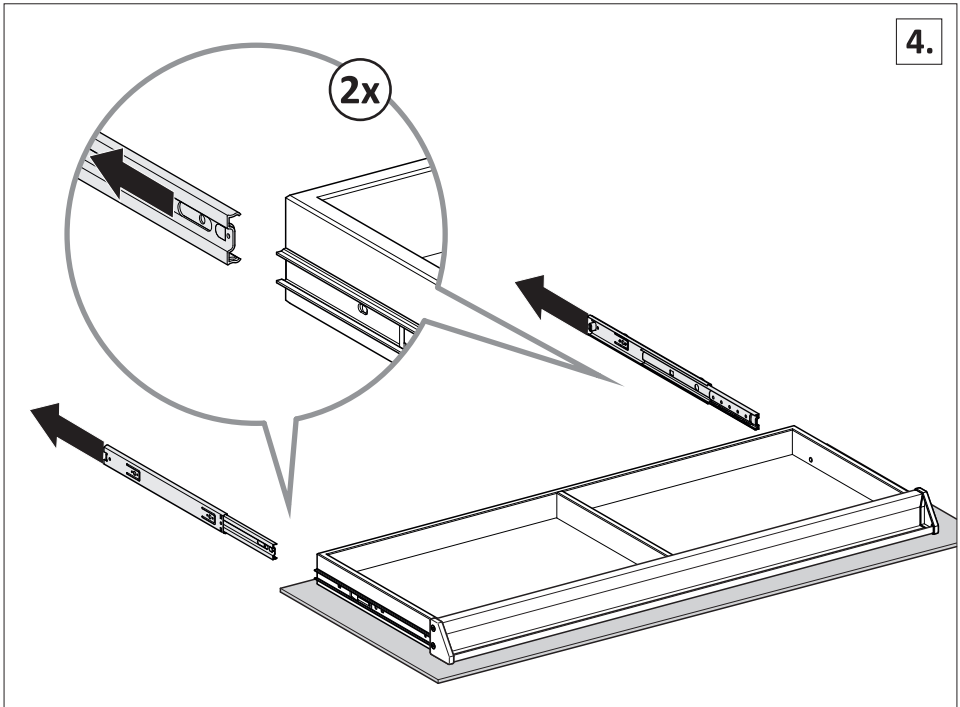
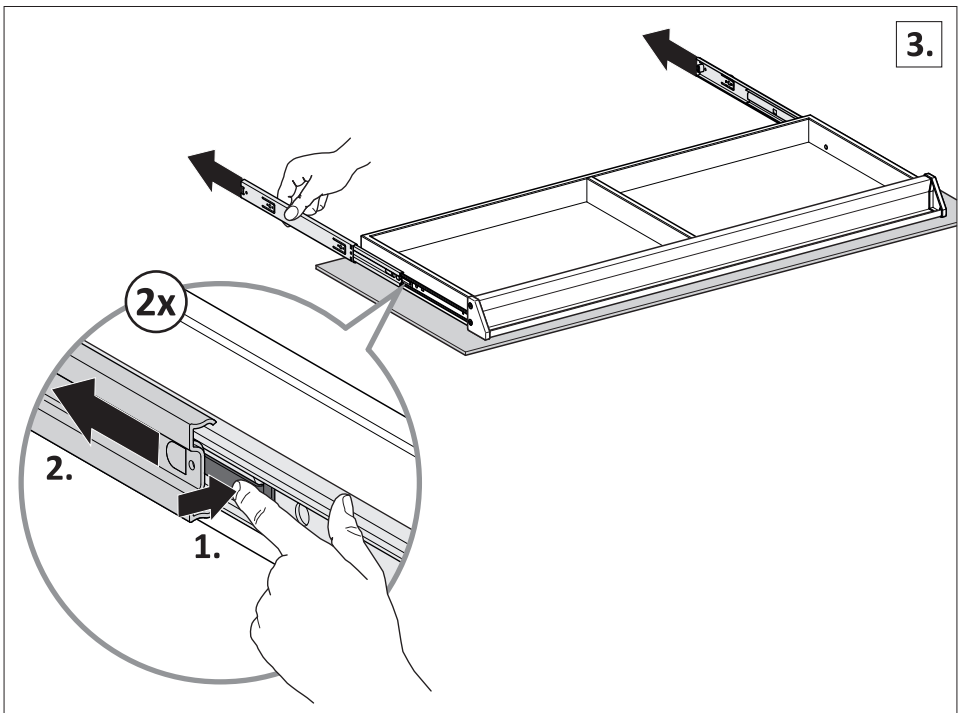

5.

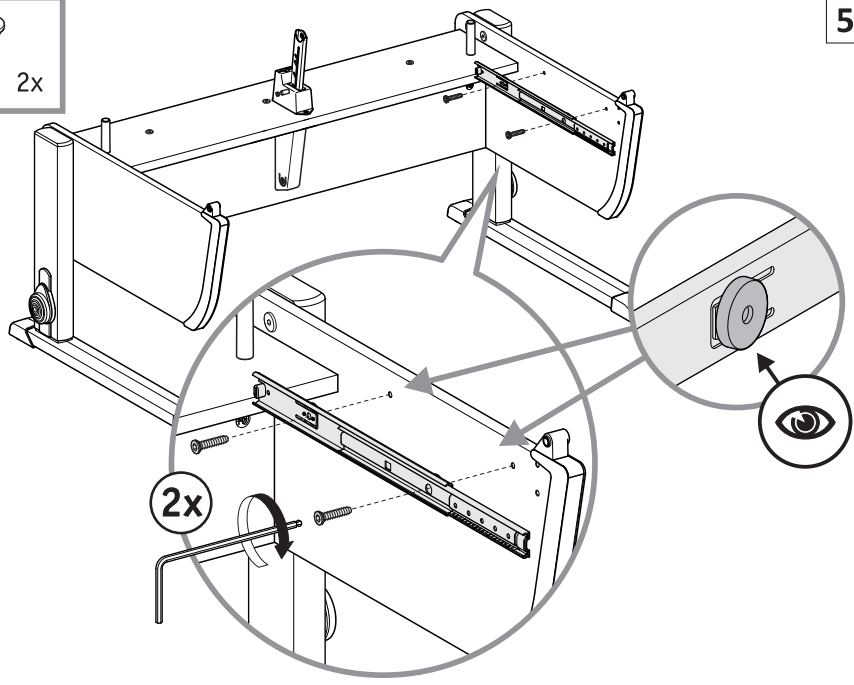
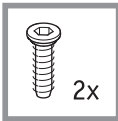

6.

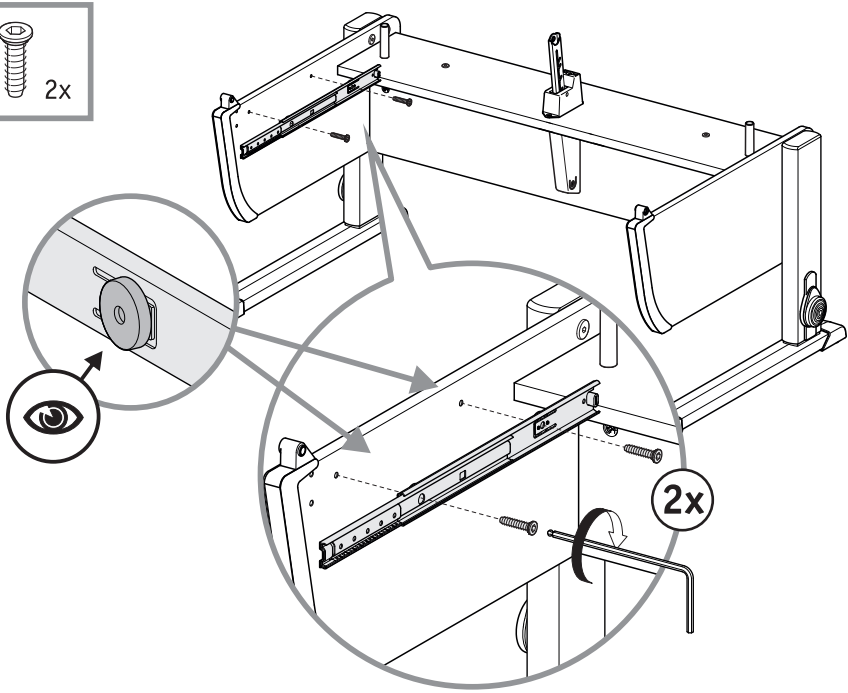
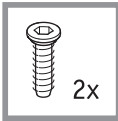

7.

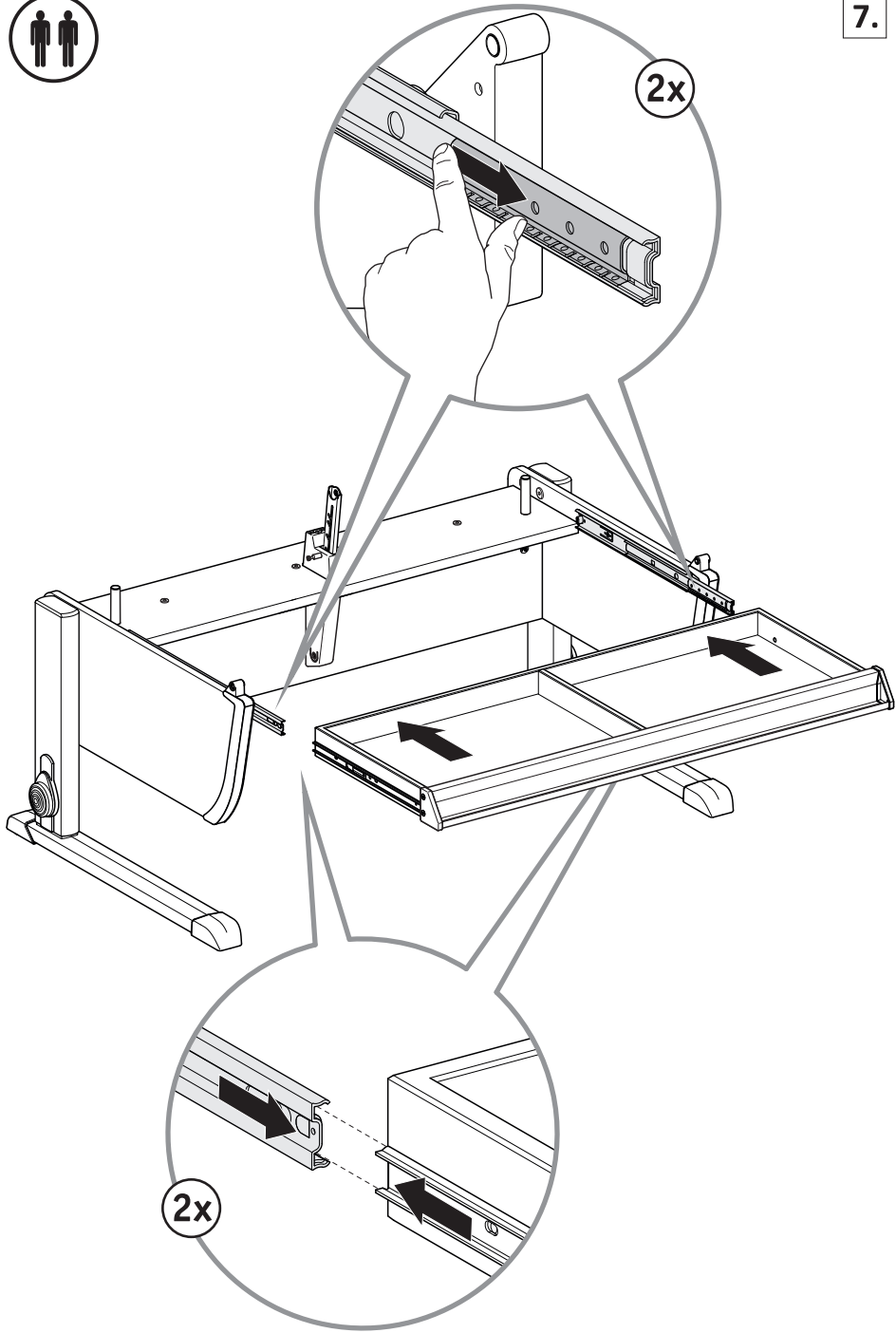

2x

2x

**D** **Wichtig!** Als erstes die Schublade ganz einschieben.

Bevor Sie weiter montieren prüfen Sie bitte, ob die Schublade fest eingerastet ist, indem Sie diese kräftig bis zum Anschlag öffnen.

**GB** **Important!** First, slide the drawer in completely.

Before you proceed assembling, please make sure that the drawer is firmly locked in place by opening the drawer all the way to the stop.

**F** **Important!** Enfoncez tout d'abord le tiroir à fond.

Vérifiez ensuite, avant de continuer le montage, que celui-ci est bien enclenché en l'ouvrant fortement jusqu'à la butée.

**I** **Importante!** In primo luogo p.f. inserire il cassetto completamente.

Prima di continuare con il montaggio, aprire il cassetto fino al punto di arresto per assicurarsi che sia messo in posizione corretta.

**E** **¡Importante!** Primero introduzca el cajón completo.

Después, antes de que usted continúe el montaje, evalúe si el cajón engranó firmemente por favor en lo que respecta a usted abra el cajón hasta el tope.

**RUS** **Важно!** Сначала вставьте ящик в направляющие и задвиньте его.

Прежде чем Вы продолжите монтаж, убедитесь, хорошо ли ящик зафиксирован на направляющих. Для этого выдвиньте его с силой до упора.

**CHN** **重要!** 首先把抽屉完全推进去，再把抽屉打开到头，确认抽屉已经卡紧，然后再继续组装。

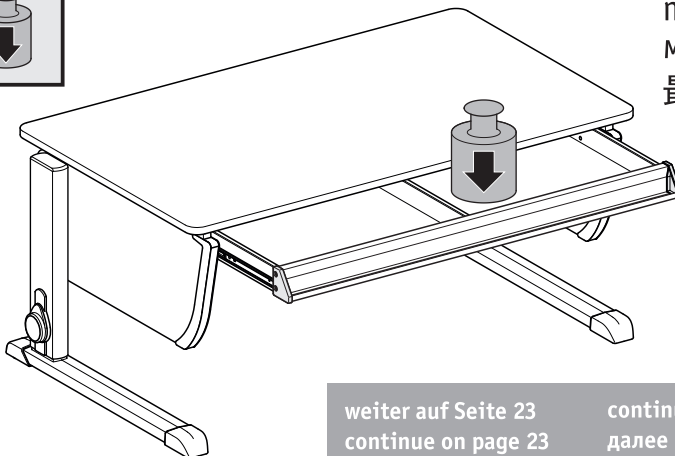

max. 6 kg  
макс. 6 кг  
最大6公斤

weiter auf Seite 23  
continue on page 23  
suite page 23  
vai a pagina 23

continúa en la página 23  
далее на стр. 23  
下接第23页

1.

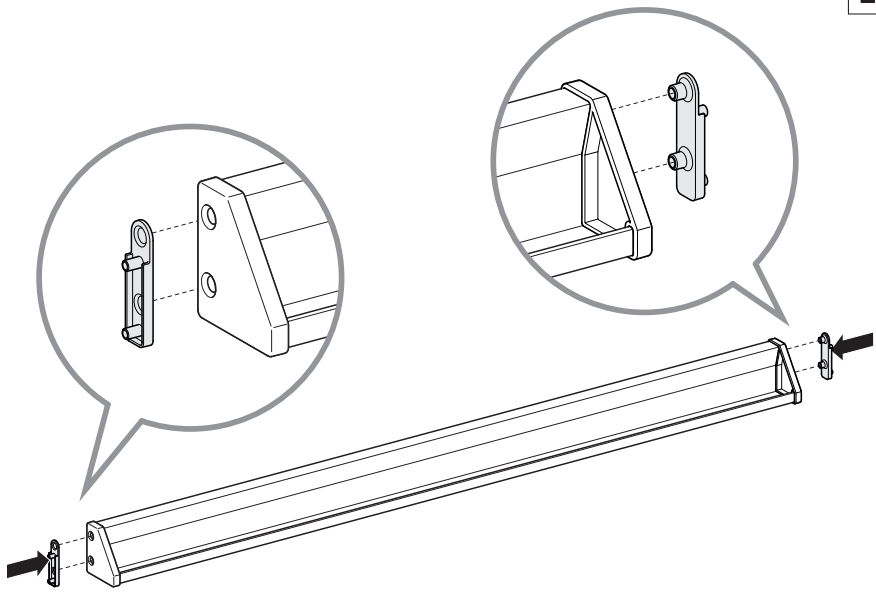

2.

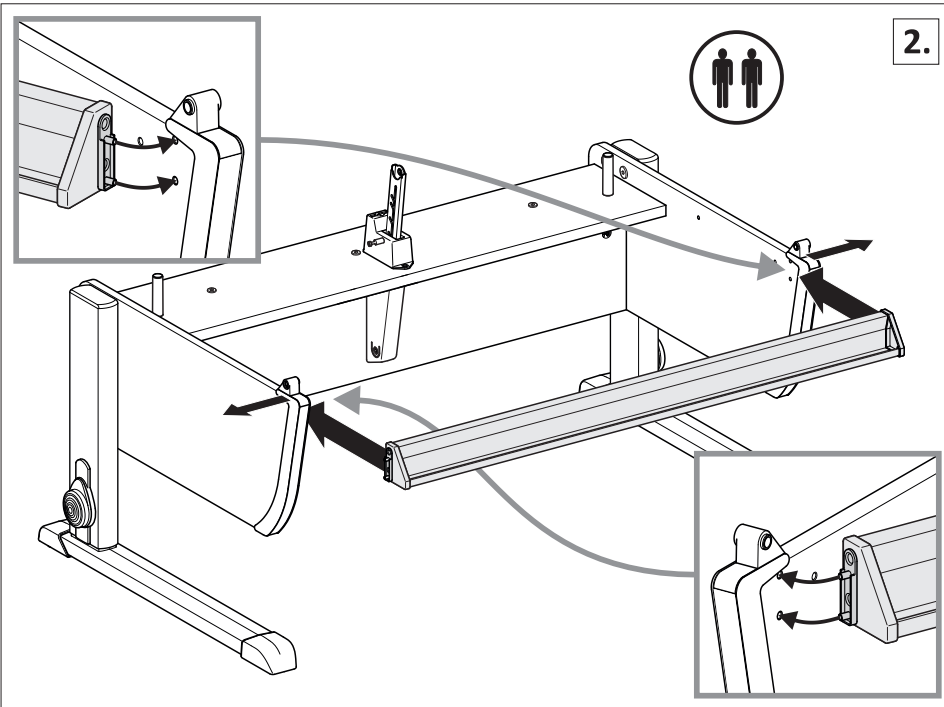

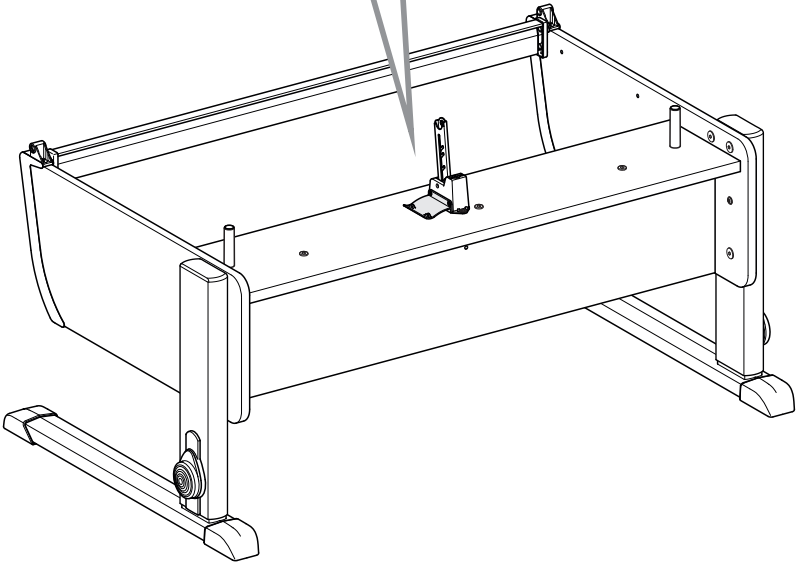
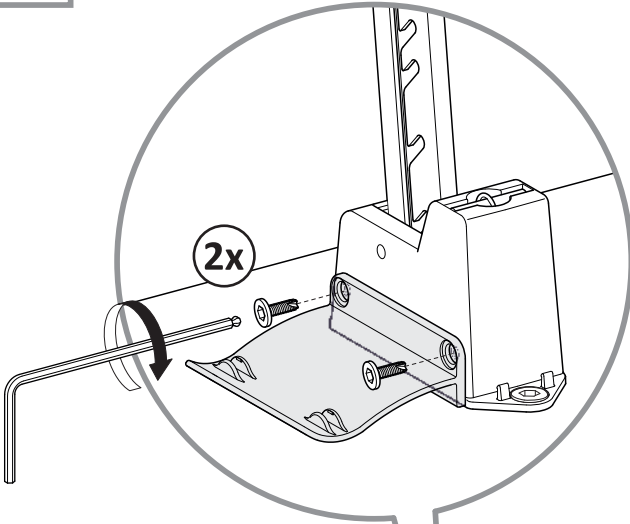
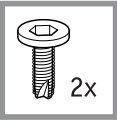

18



2x



vorn  
front  
devant  
prua  
de proa  
носовой  
前面

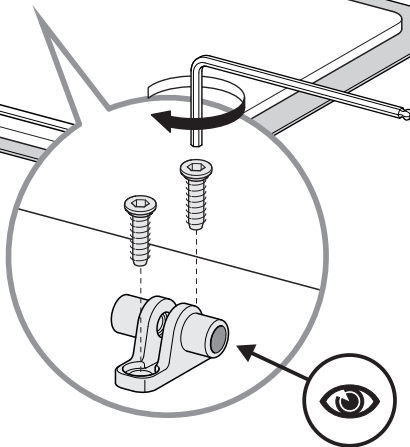

19

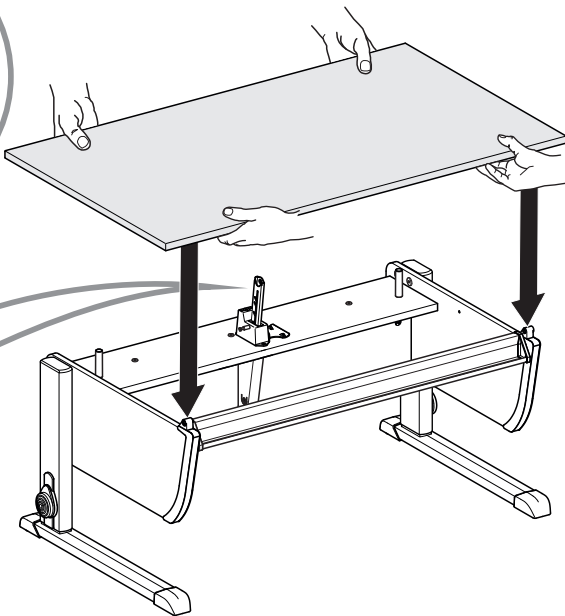
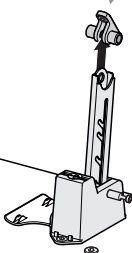
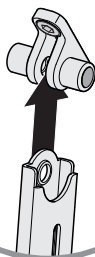

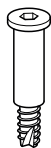
**20**

1x

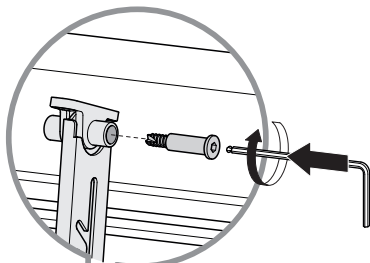

- (D) Fest drücken.
- (GB) Push firmly.
- (F) Appuyez fermement.
- (I) Spingere con fermezza.
- (E) Empujar firmemente.
- (RUS) давить твердо.
- (CHN) 用力按

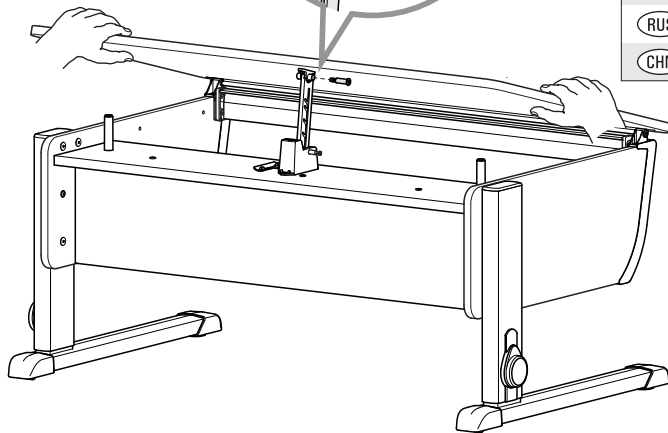
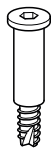
**21**

1x

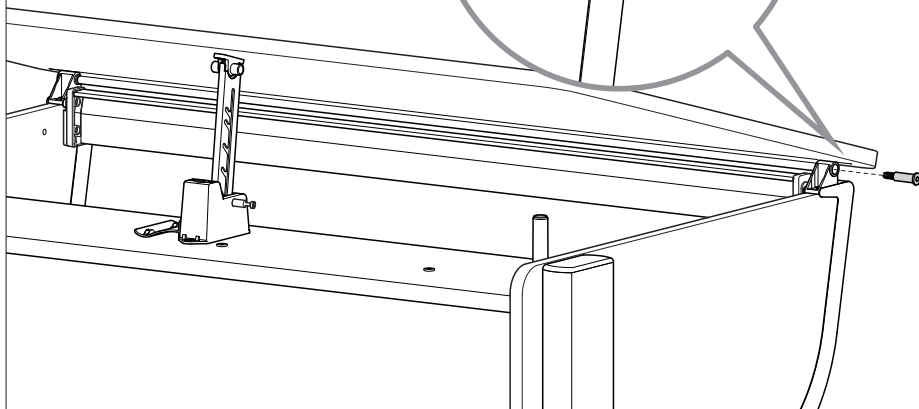
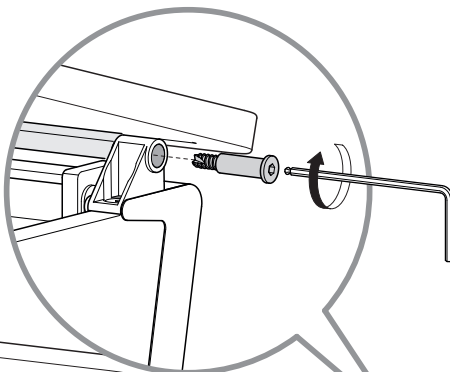

22

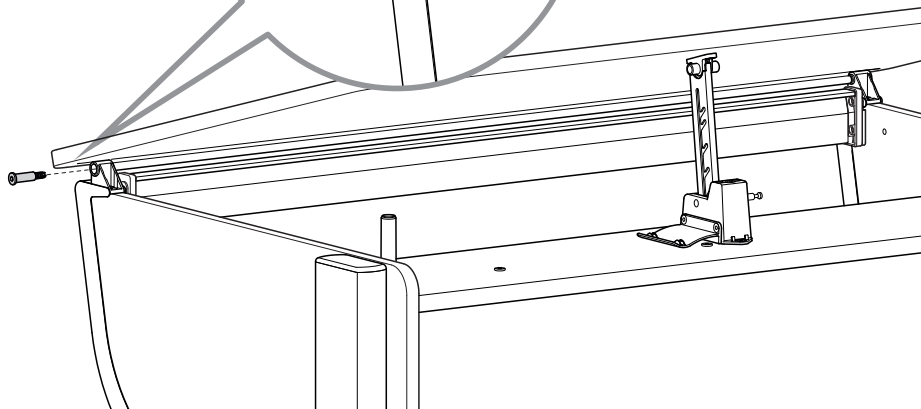
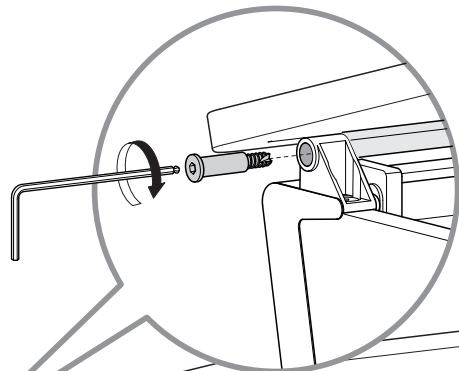

23

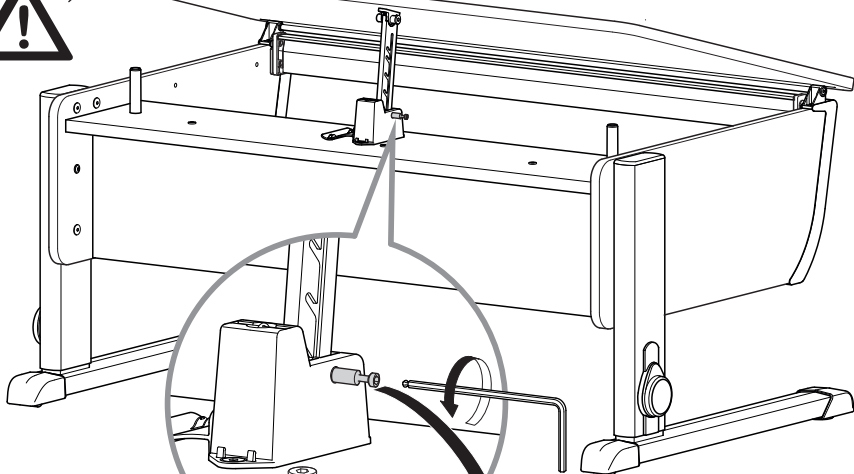
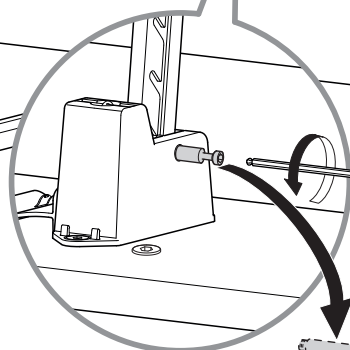

Bedienungshinweise  
Instructions for use  
Mode d'emploi  
Istruzioni per l'uso

Indicaciones de manejo  
Указания по эксплуатации  
使用提示

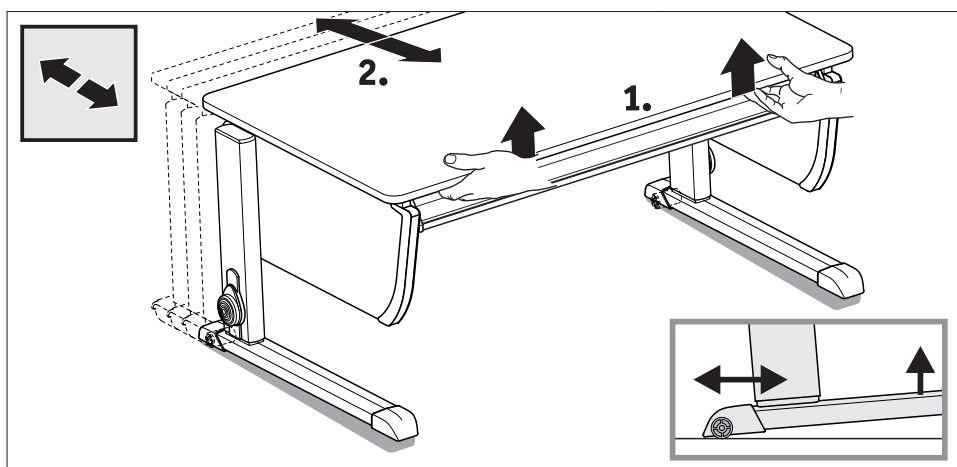
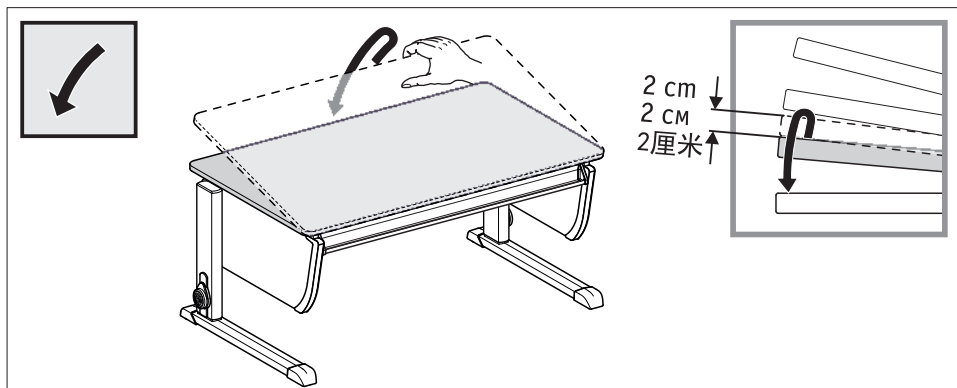
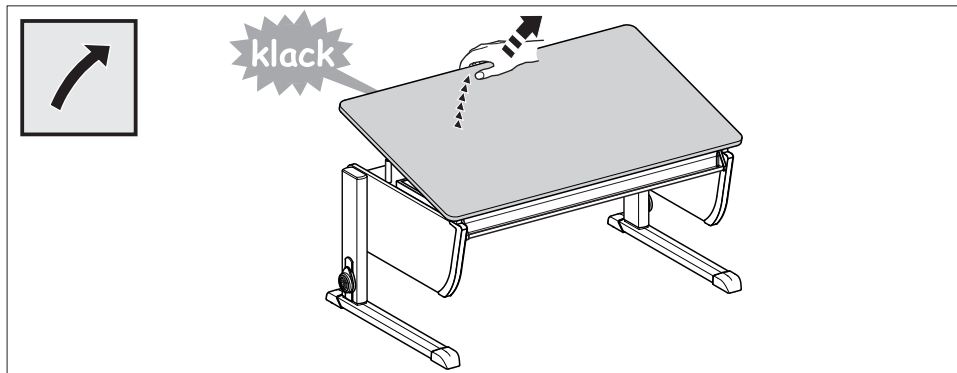

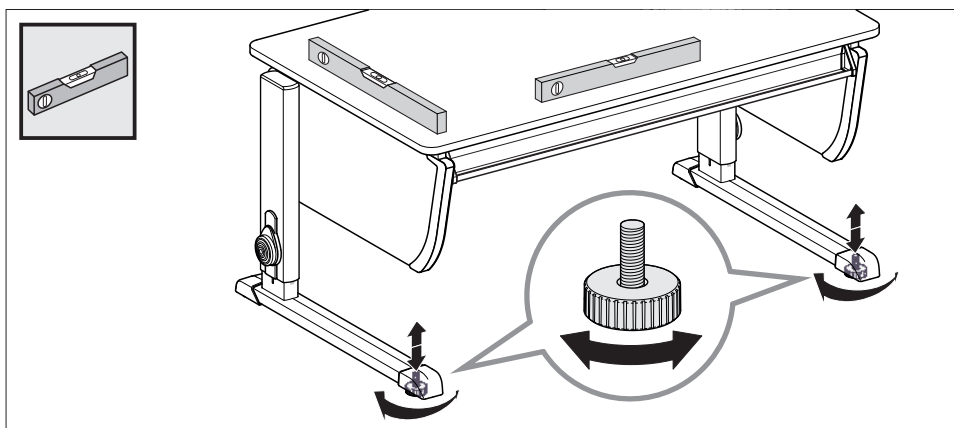

**D** Mit Hilfe der Verstell-Teller muss der Tisch waagrecht ausgerichtet werden. Dadurch wird die beste Standsicherheit erreicht, insbesondere wenn Additions (z.B. Side Top) angebaut werden.

**GB** The desk must be adjusted horizontally with the help of the adjuster plates. This will achieve optimum stability especially when additions such as the Side Top are fitted.

**F** La table doit être alignée horizontalement à l'aide du disque de réglage. La meilleure stabilité possible est ainsi atteinte, notamment en cas de montage d'éléments supplémentaires (par ex. le Side Top).

**I** Orientare la scrivania in orizzontale tramite le rotelle di regolazione. In questo modo si ottiene la migliore stabilità possibile, soprattutto se vengono aggiunti i supplementi (ad es. Side Top).

**E** Con ayuda de los discos regulables se debe nivelar horizontalmente el escritorio. De este modo se logra una mejor estabilidad, especialmente si se han de montar suplementos (p. ej. Side Top).

**RUS** С помощью дисков для выравнивания неровностей пола следует отрегулировать стол по горизонтали. За счёт этого обеспечивается оптимальная устойчивость стола, особенно если установлены навесные элементы (напр., Side Top).

**CHN** 通过调整板将桌面调平，从而可确保最佳的稳定性，尤其在加装其它配件情况下（比如旁桌板）。

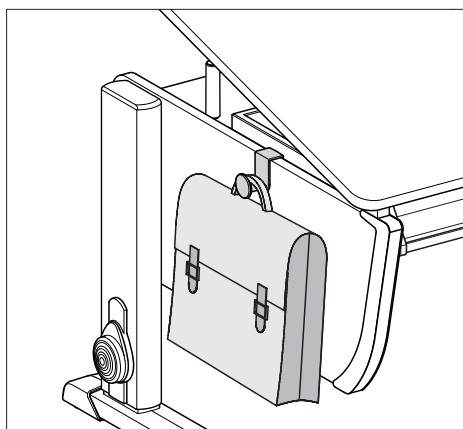
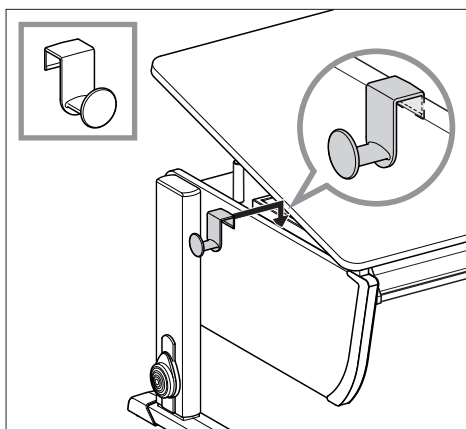

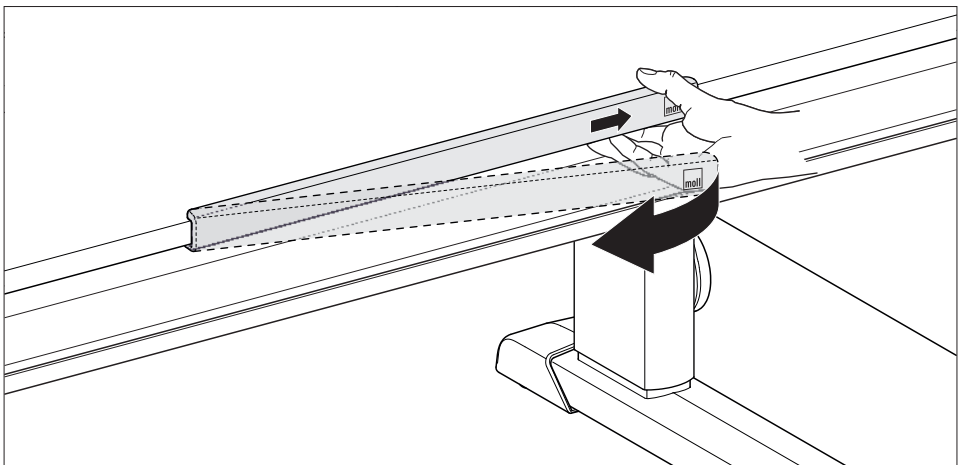
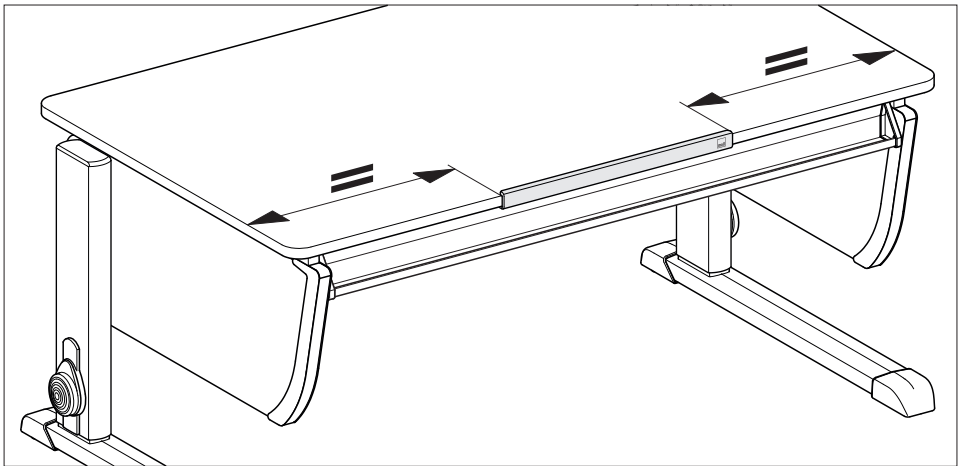
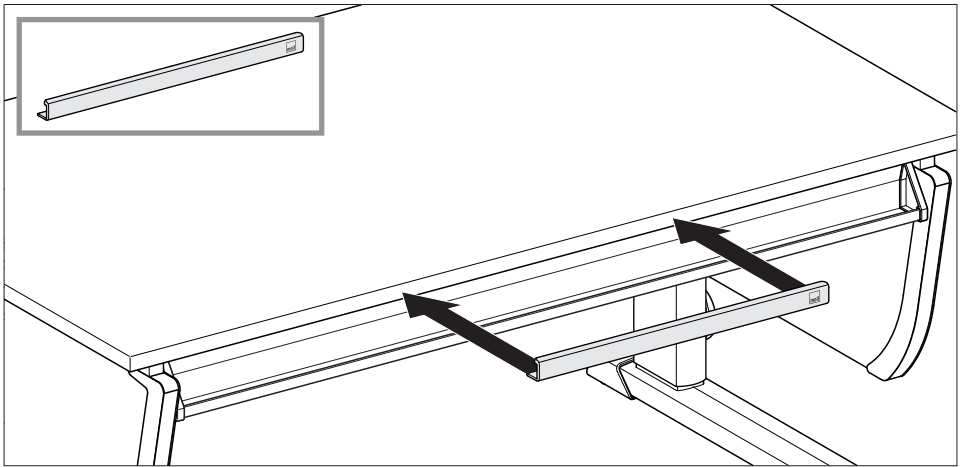

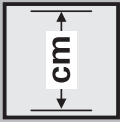

Höhenverstellung  
Height adjustment  
Réglage en hauteur  
Regolazione in altezza

Ajuste de altura  
Регулировка по высоте  
高度調整

## Classic

 ± 10 cm ± 10 厘米			
	119 cm	~ 53 cm	~ 28 - 32 cm
	127 cm	~ 56 cm	~ 30 - 34 cm
	135 cm	~ 59 cm	~ 32 - 37 cm
	143 cm	~ 63 cm	~ 36 - 39 cm
	151 cm	~ 66 cm	~ 38 - 42 cm
	159 cm	~ 69 cm	~ 40 - 44 cm
	167 cm	~ 72 cm	~ 42 - 46 cm
	175 cm	~ 75 cm	~ 44 - 48 cm
	183 cm	~ 79 cm	~ 47 - 51 cm
191 cm	~ 82 cm	~ 49 - 54 cm	

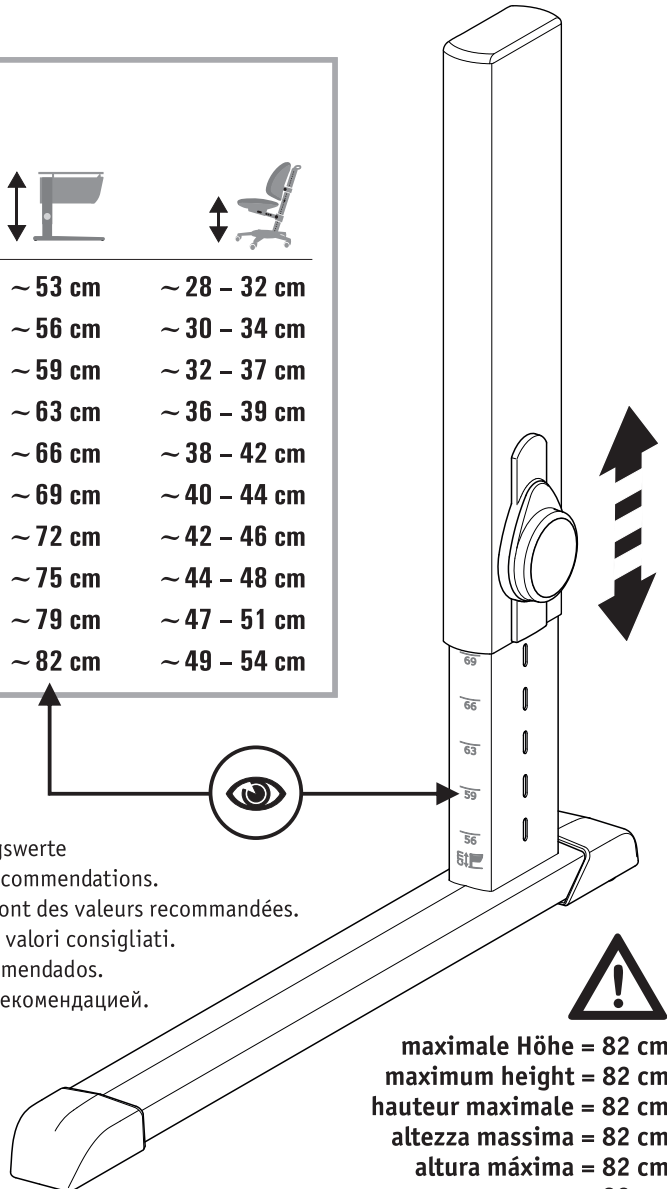

Angaben sind Empfehlungswerte  
Figures shown here are recommendations.  
Les indications fournies sont des valeurs recommandées.  
Queste informazioni sono valori consigliati.  
Los datos son valores recomendados.  
Данные являются лишь рекомендацией.  
数据为建议值

maximale Höhe = 82 cm  
maximum height = 82 cm  
hauteur maximale = 82 cm  
altezza massima = 82 cm  
altura máxima = 82 cm  
максимальная высота = 82 см  
最高 = 82 厘米

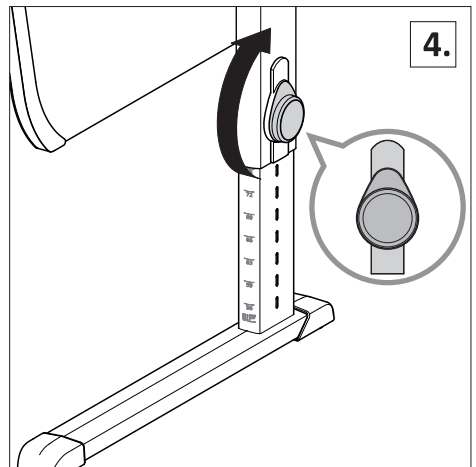
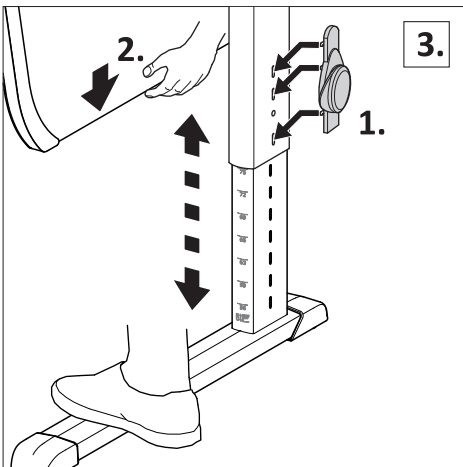
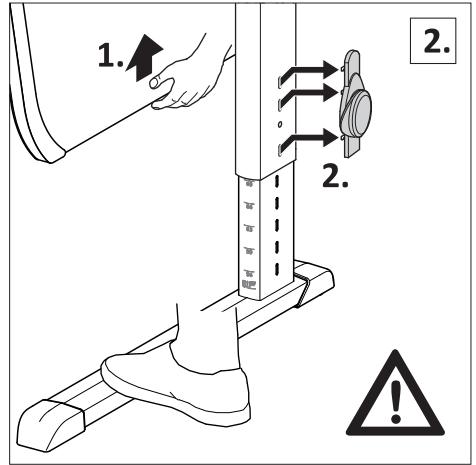
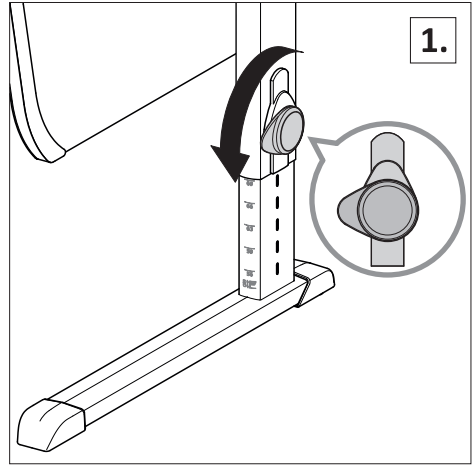
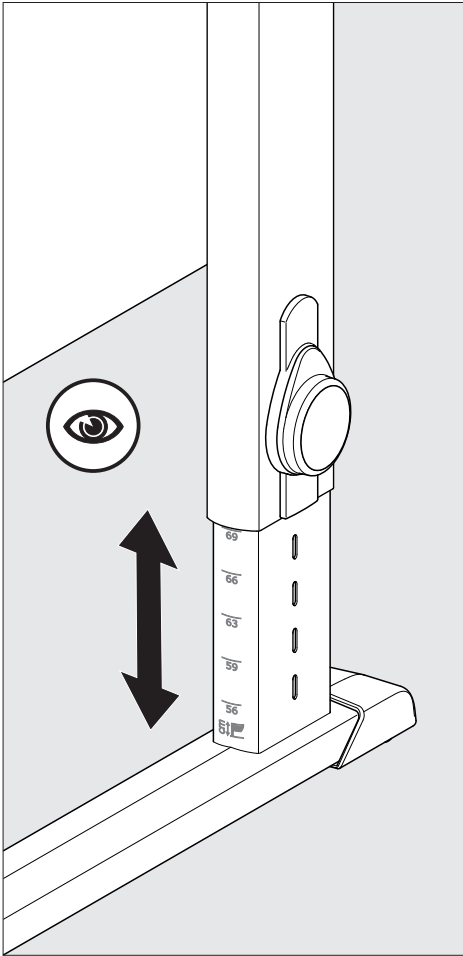



Farbwechsel  
Color change  
Changement de couleur  
Cambiare i colori

Cambio de color  
Замена цветных элементов  
换色

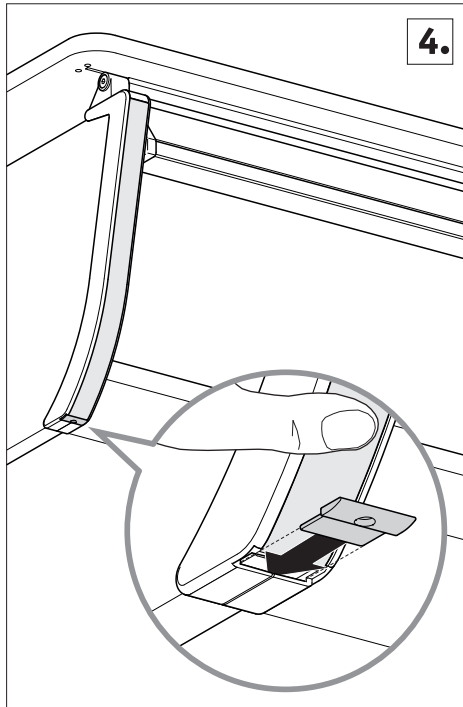
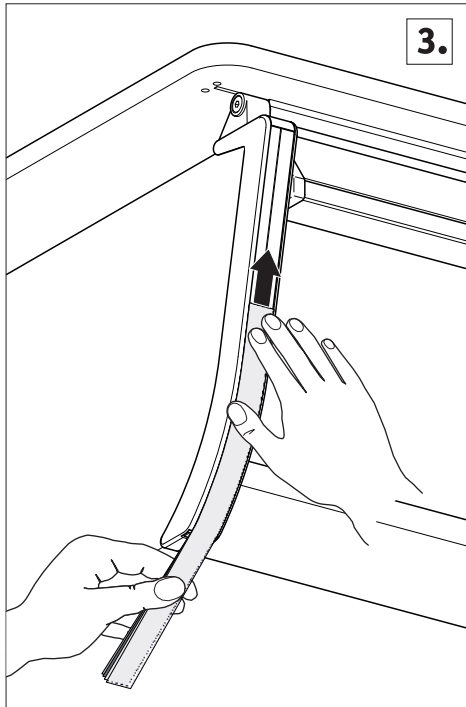
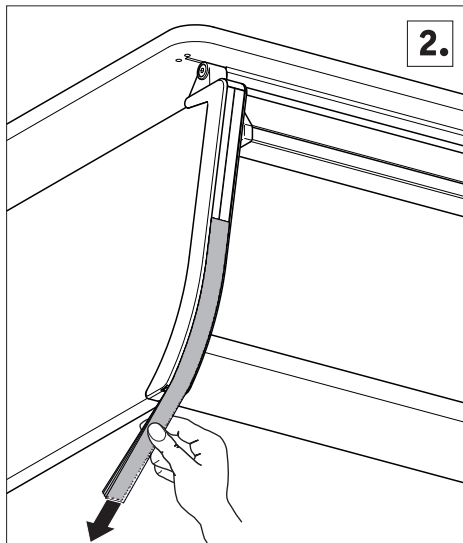
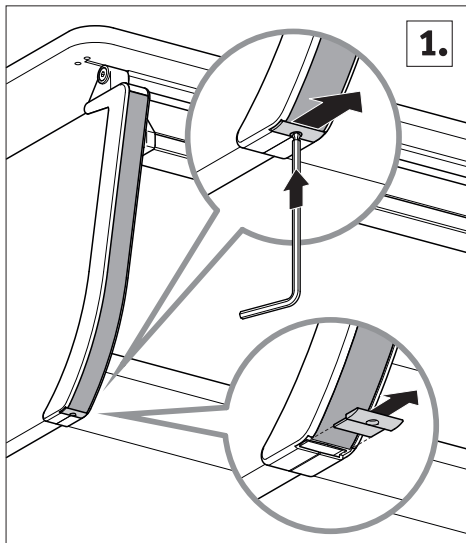

D

**Reinigung und Pflege:**

Wir empfehlen zur regelmäßigen Reinigung ein feuchtes Tuch und einen milden Haushaltsreiniger.

Bitte verwenden Sie keine Scheuermittel!

GB

**Cleaning and care:**

We recommend a damp cloth and a mild household cleaner for regular cleaning.

Please do not use abrasives!

F

**Soin et entretien:**

Pour un entretien régulier nous conseillons l'utilisation d'un chiffon légèrement humide et d'un produit d'entretien doux.

N'utilisez s.v.p aucun détergent ou produit abrasif !

I

**Pulizia e manutenzione:**

A tal fine raccomandiamo di utilizzare un panno umido e un detergente domestico delicato per la pulizia periodica.

Non utilizzare in nessun caso mezzi abrasivi!

E

**Cuidados y limpieza:**

Recomendamos para una limpieza regular emplear un trapo húmedo y un producto de limpieza doméstico suave.

Por favor, no emplee productos abrasivos.

RUS

**Чистка и уход:**

Мы рекомендуем регулярную очистку влажной тряпкой и мягким бытовым чистящим средством.

Не использовать абразивные средства!

CHN

**清理和保养:**

建议用湿布及家用柔和洗涤剂定期清洁。

不要使用强力去污剂!

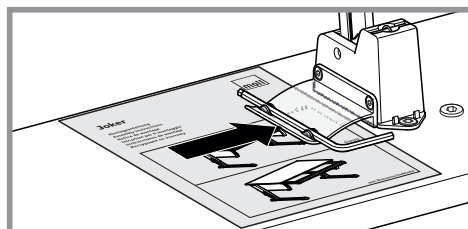
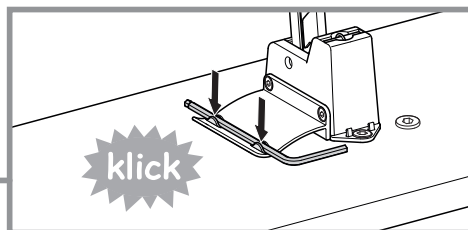
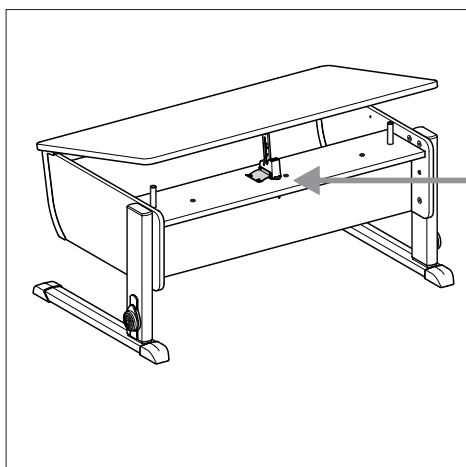



Ersatzteilübersicht  
List of spare parts  
Vue d'ensemble des pièces de rechange  
Elenco di ricambi

## Joker

02. 2020

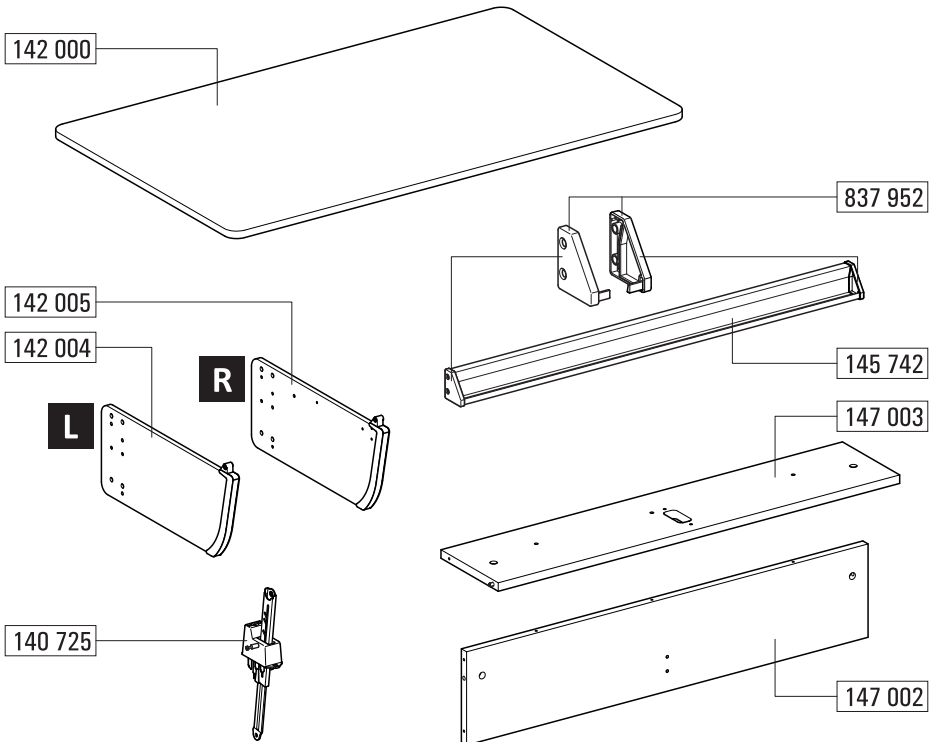

## Classic

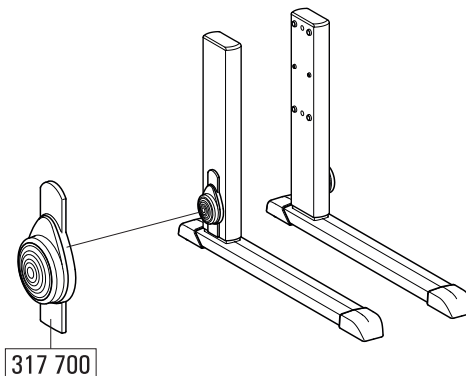

Lista de repuestos  
 Обзор запасных частей  
 备件清单

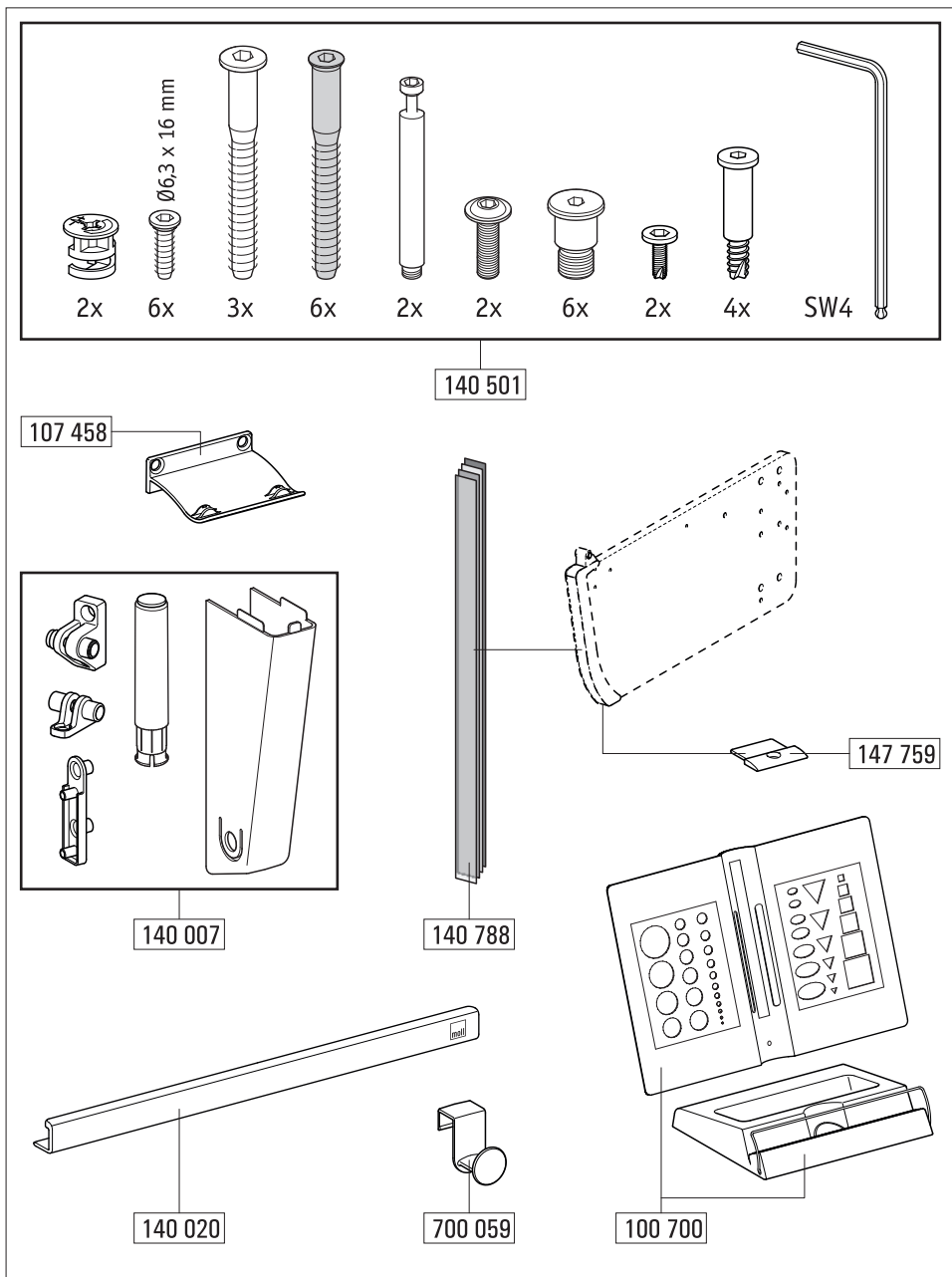

**D** Bitte bewahren Sie diese Montageanleitung auf!

**GB** Please carefully keep these assembly instructions

**F** Merci de conserver cette notice de montage!

**I** Si prega di conservare sempre le presenti istruzioni per il montaggio!

**E** Por favor, guarde estas instrucciones de montaje.

**RUS** Пожалуйста, храните данную инструкцию по монтажу

**CHN** 请妥善保存本组装说明!

服务地址 [service@moll-funktion.de](mailto:service@moll-funktion.de)



moll Funktionsmöbel GmbH  
Rechbergstraße 7  
D 73344 Gruibingen

[service@moll-funktion.de](mailto:service@moll-funktion.de)  
[www.moll-funktion.com](http://www.moll-funktion.com)

